

TM 9-2350-256-20-1

**TECHNICAL MANUAL
UNIT MAINTENANCE MANUAL
FOR
RECOVERY VEHICLE, FULL
TRACKED: MEDIUM, M88A1
NSN 2350-00-122-6826 (EIC AQA)
VOLUME I**

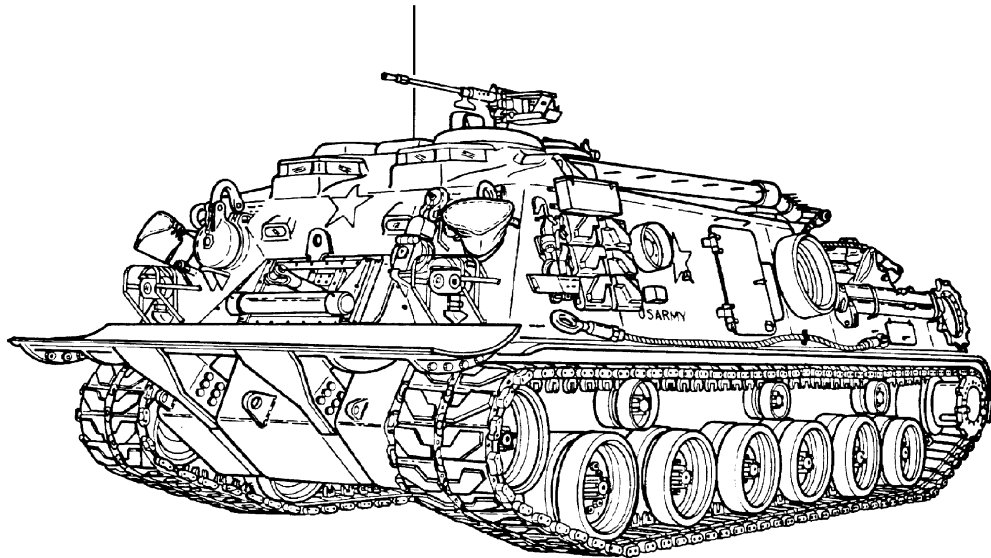

SUPERSEDURE NOTICE – This manual supersedes TM 9-2350-256-20, dated 15 July 1996, including all changes.

DISTRIBUTION STATEMENT A – Approved for public release; distribution is unlimited.

HEADQUARTERS, DEPARTMENT OF THE ARMY

NOVEMBER 2005

WARNING SUMMARY

WARNING



Carbon monoxide is a colorless, odorless, deadly poisonous gas. Breathing air with carbon monoxide produces symptoms of headache, dizziness, loss of muscular control, and drowsiness. Brain damage or death can result from severe exposure.

The exhaust fumes of fuel-burning heaters and internal combustion engines produce carbon monoxide gas. Carbon monoxide can become dangerously concentrated without adequate ventilation.

To ensure crew safety when the personnel heater or main or auxiliary engine of any vehicle is operated for any purpose:

- Do not operate personnel heater or engine of vehicle in a closed area unless it is adequately ventilated.

- Do not idle engine for long periods without ventilation blower operation. If tactical situation permits, open hatches.

- Do not drive any vehicle with inspection plates, cover plates, or engine compartment doors removed unless necessary for maintenance purposes.

During vehicle operation be aware of exhaust odors and exposure symptoms. If either is present, immediately ventilate personnel compartments. If symptoms persist, remove affected personnel and:

- Expose to fresh air

- Keep warm

- Do not permit physical exercise

- Give artificial respiration (if necessary)

- Get immediate medical attention

Neither the gas/particulate filter unit nor the field protection mask for Nuclear, Biological, and Chemical (NBC) protection will protect you from carbon monoxide poisoning.

The best defense against carbon monoxide poisoning is adequate ventilation.

WARNING



Adhesives, solvents, and sealing compounds can burn easily, give off harmful vapors, and are harmful to skin and clothing. To avoid injury or death, keep away from open flame and use in a well-ventilated area. If adhesive, solvent, or sealing compound gets on your skin or clothing, wash immediately with soap and water.

WARNING SUMMARY–Continued

WARNING



Vehicles exposed to NBC must have all air filters replaced with extreme caution by experienced and trained personnel. Unprotected personnel may experience injury or death if residual toxic agents or radioactive materials are present.

Servicing personnel must wear:

- Protective mask
- Hood
- Protective overgarments
- Chemical-protective gloves and boots

Damaged or unusable filters are considered hazardous waste. Do not dispose of them like common trash.

Filters must be placed into double-lined plastic bags.

Filters must be moved to a temporary segregation area away from the work site.

Final disposal of contaminated air filters must be in accordance with local Standard Operating Procedures (SOP).

The same procedure applies for radioactive dust contamination; however, the company NBC team should measure the radiation prior to filter removal to determine the extent of safety procedures required per the NBC Annex to the unit SOP. The segregation area in which the contaminated air filters are temporarily stored must be marked with appropriate NBC placards.

WARNING



High voltage is used in the operation of some equipment. Serious injury may result if personnel fail to observe safety precautions.

Learn the areas containing high voltage in each piece of equipment.

Do not contact high voltage connections when installing or operating this equipment.

Before working on electrical equipment, harnesses, battery cables, or starter cables turn MASTER switch to OFF position and disconnect battery ground cables.

Keep one hand away from the equipment to reduce the chances of current flowing through your body.

WARNING SUMMARY—Continued

WARNING

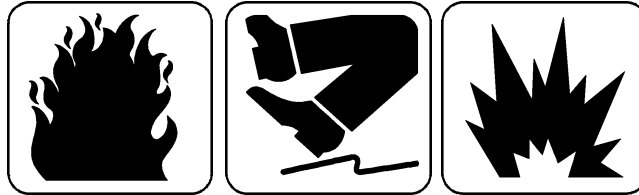

Fuel is very flammable and can explode easily. To avoid serious injury or death:

- Keep fuel away from open flame

- Keep fire extinguisher within easy reach

- Do not work on fuel system when engine is hot (fuel can be ignited by a hot engine)

- Post signs that read "NO SMOKING WITHIN 50 FEET OF VEHICLE"

Fuel and oil are also slippery and can cause falls. To avoid injury, wipe up spilled fuel or oil with rags.

WARNING

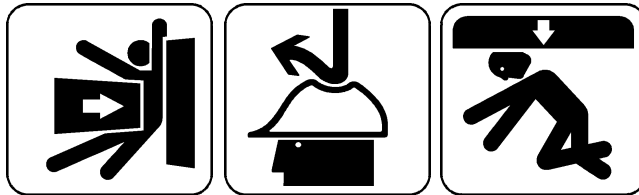

Do not stand on engine deck while operating the boom.

Do not use a 5-ton wrecker to remove engine deck and powerplant. Use only an M578 Light Recovery Vehicle or another M88A1 Medium Recovery Vehicle to remove the engine deck and powerplant.

The engine deck weighs approximately 1700 lb (771kg), and the powerplant weighs approximately 12,000 lb (5443kg). Use a lifting device with a capacity of at least 15,000 lb (6804kg) to remove engine deck and powerplant.

WARNING

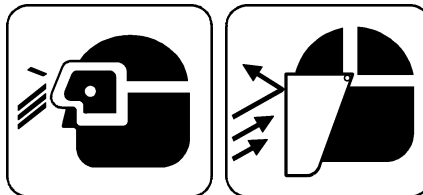

Particles blown by compressed air can be dangerous. Be certain to direct airstream away from user and other personnel in the area. Compressed air used for cleaning will not exceed 30 psi (207 kPa).

WARNING SUMMARY–Continued

WARNING



Chemical Agent Resistant Coating (CARC) paint contains isocyanate, a constituent that can cause the following allergic reactions during and after the application of the material:

- Coughing
- Shortness of breath
- Pain on respiration
- Increased sputum
- Chest tightness
- Itching and reddening of the skin
- A burning sensation of the throat and nose
- Watering of the eyes

An allergic reaction may occur after initial exposure (ranging from a few days to a few months later) producing asthmatic symptoms including coughing, wheezing, tightness in the chest, or shortness of breath. The following precautions must be observed to ensure the safety of personnel when CARC paint is applied:

For spray/brush/roller painting in confined spaces, an air line respirator is required, unless an air sampling shows exposure to be below standards. If the air sampling is below standards, either the chemical cartridge or air line respirators are required.

Spot painters applying CARC paint by brush or roller must wear clothing and gloves affording full coverage. Personnel using touchup spray kits should wear an air line respirator and protective clothing. Do not use water, alcohol, or amine-based solvents to thin or remove CARC paint. Use of these solvents with CARC paint can produce chemical reactions resulting in nausea, disease, burns, or severe illness. Do not use paint solvents to remove paint/coating from your skin.

Mix paint/coating in a well-ventilated mixing room or spraying area away from open flames. Personnel mixing paint/coating should wear eye protection.

Use paint/coating with adequate ventilation.

Personnel grinding or sanding on painted equipment should use high-efficiency, air-purifying respirators. Do not weld, cut, or apply any form of heat to CARC-coated metal until the paint has been removed from a 4-in. (102-mm) area surrounding the rework site. Substances may be released that cause skin or respiratory irritation if this is not done. Sand or grind the paint down to the base metal in the surrounding area and also remove any paint from the other side of the metal.

When sanding any paint, use the wet sanding method. Older paints may contain lead, chromates, or other toxic material. Using wet or dry sandpaper, wet down the area before starting. Keep the sandpaper wet as you sand to keep down paint dust.

INSERT LATEST UPDATED PAGES/WORK PACKAGES. DESTROY SUPERSEDED DATA.

LIST OF EFFECTIVE PAGES/WORK PACKAGES

NOTE: This is an original issue. There are no change pages.

Dates of issue for original and changed pages/work packages are:

Original ..0 ..27 November 2005

TOTAL NUMBER OF VOULMES IS 2, TOTAL NUMBER OF PAGES FOR FRONT AND REAR MATTER IS 125 AND TOTAL NUMBER OF WORK PACKAGES IS 491 CONSISTING OF THE FOLLOWING:

Page / WP No.	*Change No.	Page / WP No.	*Change No.	Page / WP No.	*Change No.	Page / WP No.	*Change No.
Volume 1							
Cover.....	0	DA Form 2028 (3 copies).....	0				
a-d.....	0	Authentication page.....	0				
Change transmittal page.....	0	Metric Conversion Chart.....	0				
Blank.....	0	PIN page.....	0				
A.....	0						
B Blank.....	0						
Title.....	0						
Blank.....	0						
i-xviii.....	0						
WP 0001 00-1-0149 00-3.....	0						
WP 0149 00-4 Blank.....	0						
Index 1-22.....	0						
DA Form 2028 Sample.....	0						
DA Form 2028 (2 copies).....	0						
Authentication page.....	0						
Metric Conversion Chart.....	0						
PIN page.....	0						
Volume 2							
Cover.....	0						
a-d.....	0						
Title.....	0						
Blank.....	0						
i-xii.....	0						
WP 0150 00-1-0491 00-7.....	0						
WP 0491 00-8 Blank.....	0						
Index 1-22.....	0						
Fold out 1.....	0						
Foldout 3.....	0						
Foldout 5.....	0						
Foldout 7.....	0						
Foldout 9.....	0						
DA Form 2028 Sample.....	0						

* Zero in this column indicates an original page or work package

A/B blank

HEADQUARTERS,
DEPARTMENT OF THE ARMY
WASHINGTON, D.C., 27 NOV 2005

TECHNICAL MANUAL
UNIT MAINTENANCE MANUAL
FOR
RECOVERY VEHICLE, FULL TRACKED: MEDIUM, M88A1
NSN 2350-00-122-6826
(EIC AQA)

REPORTING ERRORS AND RECOMMENDING IMPROVEMENTS

You can help improve this publication. If you find any mistakes or if you know of a way to improve the procedures, please let us know. Submit DA Form 2028 (Recommended Changes to Publications and Blank Forms), through the Internet, on the Army Electronic Product Support (AEPS) website. The internet address is <http://aeps.ria.army.mil>. If you need a password, scroll down and click on "ACCESS REQUEST FORM". The DA Form 2028 is located in the ON-LINE FORMS PROCESSING section of the AEPS. Fill out the form and click on SUBMIT. Using this form on the AEPS will enable us to respond quicker to your comments and better manage the DA Form 2028 program. You may also mail, fax, or email your letter, or DA Form 2028 direct to: Technical Publication Information Office, TACOM-RI, 1 Rock Island, IL 61299-7630. The email address is TACOM-TECH-PUBS@ria.army.mil. The fax number is DSN 793-0726 or Commercial (309) 782-0726. A reply will be furnished directly to you.

***SUPERSEDURE NOTICE** – This manual supersedes TM 9-2350-256-20, dated 15 July 1996, including all changes.

DISTRIBUTION STATEMENT A – Approved for public release; distribution is unlimited.

TABLE OF CONTENTS

WP Sequence No.

WARNING SUMMARY

HOW TO USE THIS MANUAL

GENERAL INFORMATION.....0001 00

CHAPTER 1 – UNIT INTRODUCTORY INFORMATION WITH THEORY OF OPERATION

Equipment Description and Data.....	0002 00
Powerplant Theory of Operation.....	0003 00
Lubrication System Theory of Operation.....	0004 00
Fuel Supply, Air Intake, and Exhaust Systems Theory of Operation.....	0005 00
Manifold Air Induction Heater System Theory of Operation.....	0006 00
Cooling System Theory of Operation.....	0007 00
Electrical Systems and Circuits Theory of Operation.....	0008 00
Transmission and Output Reduction Drives Theory of Operation.....	0009 00
Tracks and Suspension Systems Theory of Operation.....	0010 00
Fixed Fire Extinguisher System Theory of Operation.....	0011 00
Winches, Spade Assembly, and Hoisting Boom Theory of Operation.....	0012 00
Mechanical Transmission and Main Hydraulic System Pump Theory of Operation.....	0013 00
Main Hydraulic System Theory of Operation.....	0014 00
Auxiliary Power Unit (APU) Theory of Operation.....	0015 00
M8A3 Gas/Particulate Filter Unit (GPFU) Theory of Operation.....	0016 00
M239 Smoke Grenade Launcher System Theory of Operation.....	0017 00
Exhaust Smoke Generating System Theory of Operation.....	0018 00
Deep Water Fording Kit Theory of Operation.....	0019 00
Radio Interference Suppression Theory of Operation.....	0020 00

CHAPTER 2 – UNIT TROUBLESHOOTING PROCEDURES

Troubleshooting Index.....	0021 00
Engine Troubleshooting Procedure.....	0022 00
Fuel, Air Intake, and Exhaust Systems Troubleshooting Procedure.....	0023 00
Oil Cooling System Troubleshooting Procedure.....	0024 00
Ventilation Blower Assembly Troubleshooting Procedure.....	0025 00
Transmission Center Section and Output Reduction Gears Troubleshooting Procedure.....	0026 00
Driver’s Controls Troubleshooting Procedure.....	0027 00
Tracks and Suspension Troubleshooting Procedure.....	0028 00
Mechanical Transmission Troubleshooting Procedure.....	0029 00
Main Winch Troubleshooting Procedure.....	0030 00
Hoist Winch Troubleshooting Procedure.....	0031 00
Hoisting Boom Troubleshooting Procedure.....	0032 00
Spade Troubleshooting Procedure.....	0033 00
Main Hydraulic System Troubleshooting Procedure.....	0034 00
Auxiliary Hydraulic System Troubleshooting Procedure.....	0035 00
APU Troubleshooting Procedure.....	0036 00
Main Hydraulic Pump Troubleshooting Procedure.....	0037 00
Auxiliary Hydraulic Pump Troubleshooting Procedure.....	0038 00
Mechanical Transmission—Hydraulic Troubleshooting Procedure.....	0039 00
Simplified Test Equipment/Internal Combustion Engine-Reprogrammable (STE/ICE-R) Troubleshooting Procedure.....	0040 00

TABLE OF CONTENTS—Continued

	<u>WP Sequence No.</u>
Battery Power Circuit Troubleshooting Procedure.....	0041 00
Master Relay and Slave Receptacle Troubleshooting Procedure.....	0042 00
Engine Starting System Troubleshooting Procedure.....	0043 00
Engine Manifold Preheater System Troubleshooting Procedure.....	0044 00
Engine Fuel Shutoff Solenoid Troubleshooting Procedure.....	0045 00
Fire Extinguisher Engine Shutoff Light Troubleshooting Procedure.....	0046 00
Electric In-Tank Fuel Pump Troubleshooting Procedure.....	0047 00
Fuel Gage Troubleshooting Procedure.....	0048 00
Engine Oil Temperature Gage Troubleshooting Procedure.....	0049 00
Engine Oil Pressure Gage Troubleshooting Procedure.....	0050 00
Power Control Lever Switch Troubleshooting Procedure.....	0051 00
Transmission Oil Temperature Gage Troubleshooting Procedure.....	0052 00
Transmission Oil Pressure Gage Troubleshooting Procedure.....	0053 00
Engine Generator (Dual Voltage) Troubleshooting Procedure.....	0054 00
Engine Generator (Single Voltage) Troubleshooting Procedure.....	0055 00
APU Generator System (Dual Voltage) Troubleshooting Procedure.....	0056 00
APU Generator System (Single Voltage) Troubleshooting Procedure.....	0057 00
Generator Indicator Gage Troubleshooting Procedure.....	0058 00
APU Starting System Troubleshooting Procedure.....	0059 00
APU Fuel Solenoid System Troubleshooting Procedure.....	0060 00
APU Low Oil Pressure System Troubleshooting Procedure.....	0061 00
APU High Air Temperature System Troubleshooting Procedure.....	0062 00
APU Engine Oil Pressure Gage Circuit Troubleshooting Procedure.....	0063 00
Mechanical Transmission Oil Pressure Light Troubleshooting Procedure.....	0064 00
Master Warning Light Troubleshooting Procedure.....	0065 00
Powerplant Warning Horn Troubleshooting Procedure.....	0066 00
External Vehicle Warning Horn Troubleshooting Procedure.....	0067 00
Bilge Pump System and Electrical Accessories Panel Power Outlet Troubleshooting Procedure.....	0068 00
Personnel Heater Control System Troubleshooting Procedure.....	0069 00
Communication System Troubleshooting Procedure.....	0070 00
Dome Lights Troubleshooting Procedure.....	0071 00
Passive Night Viewer Troubleshooting Procedure.....	0072 00
Driver’s Periscope Troubleshooting Procedure.....	0073 00
Fixed Spotlight Troubleshooting Procedure.....	0074 00
Troublelight Assembly Troubleshooting Procedure.....	0075 00
Winch Light Troubleshooting Procedure.....	0076 00
Gage Panel Lights Troubleshooting Procedure.....	0077 00
Service Headlights Troubleshooting Procedure.....	0078 00
High Beam Indicator Troubleshooting Procedure.....	0079 00
Service Stoplight Troubleshooting Procedure.....	0080 00
B.O. Service Condition (IR Headlights) Troubleshooting Procedure.....	0081 00
B.O. Service Condition (B.O. Stoplight) Troubleshooting Procedure.....	0082 00
B.O. Marker Condition Troubleshooting Procedure.....	0083 00
B.O. Drive Condition Troubleshooting Procedure.....	0084 00
Rigger’s Lights and Front Signal Light Troubleshooting Procedure.....	0085 00
Ventilation Blower System Troubleshooting Procedure.....	0086 00
Engine Generator Blower Motor Troubleshooting Procedure.....	0087 00
M8A3 Filter Unit System Troubleshooting Procedure.....	0088 00
M239 Smoke Grenade Launcher System Troubleshooting Procedure.....	0089 00

TABLE OF CONTENTS—Continued

	<u>WP Sequence No.</u>
Hydraulic Reservoir Monitoring System Switches and Lights Troubleshooting Procedure.....	0090 00
Hydraulic Reservoir Monitoring System Gage Transmitter Troubleshooting Procedure.....	0091 00
Exhaust Smoke Generating System Troubleshooting Procedure	0092 00
Fuel/Water Separator Control Module System Troubleshooting Procedure.....	0093 00
 CHAPTER 3 – UNIT MAINTENANCE INSTRUCTIONS	
Service Upon Receipt.....	0094 00
Preventive Maintenance Checks and Services PMCS Procedures Introduction.....	0095 00
Preventive Maintenance Checks and Services	0096 00
Lubrication Instructions	0097 00
 CHAPTER 4 – UNIT MAINTENANCE INSTRUCTIONS	
Powerplant Replacement Removal, Installation.....	0098 00
Groundhop Maintenance Installation, Testing, Removal	0099 00
Emergency Boom Operation General, Preparation for Use, Servicing, Placing in Service	0100 00
Engine Mounting Bracket Maintenance Removal, Disassembly, Assembly, Installation	0101 00
Engine Rear Mount and Base Assembly Replacement Removal, Installation.....	0102 00
Engine Oil Filter Servicing Instruction Plate Replacement Removal, Installation.....	0103 00
Engine Damper Housing, Oil Filter, and Related Parts Maintenance Removal, Cleaning, Installation.....	0104 00
Oil Level Indicator and Related Parts Replacement Removal, Installation	0105 00
Oil Filler Tube and Related Parts Replacement Removal, Installation	0106 00
Oil Pan and Related Parts Replacement Removal, Installation	0107 00
Crankcase Breather Tube Replacement Removal, Installation.....	0108 00
Cylinder Head Oil Pan Drain Tubes and Related Parts Replacement Removal, Installation.....	0109 00
Oil Cooler Pressure-Actuated Bypass Valve Replacement Removal, Installation.....	0110 00
Generator Air Intake Tube Replacement Removal, Installation.....	0111 00
Engine Idle Speed Adjustment.....	0112 00
Engine Solenoid Speed Adjustment.....	0113 00
 CHAPTER 5 – UNIT MAINTENANCE INSTRUCTIONS	
Fuel Injector Tubes, Brackets, and Related Parts Replacement Removal, Installation.....	0114 00
Engine Right and Left Upper Covers Replacement Removal, Installation.....	0115 00
Electric Fuel Pump Maintenance Removal, Disassembly, Assembly, Installation, Testing... ..	0116 00
Fuel Transfer Pump Hoses and Related Parts Replacement Removal, Installation	0117 00
Fuel Pump (Gear Type), Lines, and Related Parts Maintenance Removal, Installation, Testing	0118 00
Fuel Injector Fuel Return Hose Replacement Removal, Installation.....	0119 00
Fuel Filler Tube and Filler Strainer Maintenance Removal, Disassembly, Cleaning, Assem- bly, Installation	0120 00
Fuel Level Transmitter Replacement Removal, Installation	0121 00
Purge Pump/Handle/Lever Maintenance Removal, Disassembly, Assembly, Installation.....	0122 00
Fuel Valve Lines and Fittings Maintenance Removal, Repair, Installation	0123 00
Engine Fuel Manual Shutoff Control Maintenance Removal, Installation, Adjustment.....	0124 00
Fuel Control Valves and ID Plates Replacement Removal, Installation	0125 00
Fuel Check Valve Maintenance Removal, Installation, Testing	0126 00
Primary Fuel Filter Maintenance Servicing, Removal, Disassembly, Cleaning, Assembly, Installation.....	0127 00
Fuel/Water Separator Filter Elements Replacement Removal, Installation.....	0128 00
Fuel/Water Separator Filter Unit Replacement Removal, Installation.....	0129 00

TABLE OF CONTENTS—Continued

	<u>WP Sequence No.</u>
Fuel/Water Separator Automatic Drain System and Solenoid Valve Replacement Removal, Installation.....	0130 00
Manifold Heater Fuel Supply Solenoid Valve and Fuel Filter Replacement Removal, Installation.....	0131 00
Manifold Heater Ignition Unit Replacement Removal, Installation.....	0132 00
Manifold Heater Fuel Return Solenoid Valve Replacement Removal, Installation.....	0133 00
Manifold Heater Nozzle Assembly Maintenance Removal, Disassembly, Assembly, Installation.....	0134 00
Manifold Heater Operation Check.....	0135 00
Manifold Heater Fuel Lines and Fittings Replacement Removal, Installation.....	0136 00
Air Cleaner Maintenance Removal, Disassembly, Service, Assembly, Installation.....	0137 00
Air Cleaner Restriction Gage Assembly Replacement Removal, Installation.....	0138 00
Air Intake Hoses Replacement Removal, Installation.....	0139 00
Engine Air Inlet Seal Replacement Removal, Installation.....	0140 00
Exhaust Pipes Replacement Removal, Installation.....	0141 00
Exhaust Manifold Clamps Replacement Removal, Installation.....	0142 00
 CHAPTER 6 – UNIT MAINTENANCE INSTRUCTIONS	
Engine Cooling Fan Shroud Seals Replacement Removal, Installation.....	0143 00
Engine Cooling Fans Replacement Removal, Installation.....	0144 00
Engine Cooling Fan Housings Maintenance Removal, Disassembly, Assembly, Installation.....	0145 00
Engine Cooling Fan Shroud and Related Parts Replacement Removal, Installation.....	0146 00
Engine Cooling Fan Vertical Shaft Oil Seals Maintenance Removal, Disassembly, Assem- bly, Installation.....	0147 00
Engine Oil Coolers and Screens Maintenance Removal, Inspection, Cleaning, Installation.....	0148 00
Engine Oil Cooler Lines Maintenance Removal, Cleaning, Inspection, Installation.....	0149 00
 INDEX.....	 INDEX-1
 Volume 2	
 WARNING SUMMARY, VOL 2	
 CHAPTER 7 – UNIT MAINTENANCE INSTRUCTIONS, VOL 2	
Engine Generator, Cradle, Support, and Related Parts Maintenance Removal, Disassembly, Assembly, Installation, Vol 2.....	0150 00
Master Relay Housing (Dual and Single Voltage) Replacement Removal, Installation, Vol 2.....	0151 00
Engine Starter, Solenoid Relay, and Bracket Replacement Removal, Installation, Vol 2.....	0152 00
Batteries, Battery Trays, and Terminal Maintenance Removal, Repair, Installation, Vol 2.....	0153 00
Voltage Regulator and Related Parts (Dual Voltage) (11672403) Replacement Removal, Installation, Vol 2.....	0154 00
Voltage Regulator and Related Parts (Single Voltage) (11659111-1) Replacement Removal, Installation, Vol 2.....	0155 00
Engine and APU Armature Relay (Single Voltage) Replacement Removal, Installa- tion, Vol 2.....	0156 00
Gage Panel Assembly Maintenance Removal, Disassembly, Assembly, Installation, Vol 2.....	0157 00
Electrical Accessories Panel Maintenance Removal, Disassembly, Assembly, Installa- tion, Vol 2.....	0158 00
Main Switch Panel Assembly Maintenance Removal, Disassembly, Assembly, Installa- tion, Vol 2.....	0159 00
Flasher System Panel and Related Parts Replacement Removal, Installation, Vol 2.....	0160 00
Heater Control Box Replacement Removal, Installation, Vol 2.....	0161 00

TABLE OF CONTENTS—Continued

	<u>WP Sequence No.</u>
Switching Relay Box Assembly (Single Voltage Regulator) Maintenance Removal, Disassembly, Assembly, Calibration, Installation, Vol 2	0162 00
Neutral Safety Switch Maintenance Removal, Disassembly, Assembly, Installation, Adjustment, Vol 2	0163 00
Driver’s Passive Night Viewer Switch and Light and B.O. Receiver Switch and Light Maintenance Removal, Disassembly, Assembly, Installation, Vol 2	0164 00
Fire Extinguisher Interlock Switch Assembly Maintenance Removal, Disassembly, Assembly, Installation, Vol 2	0165 00
Power Control Lever Switch Maintenance Removal, Disassembly, Assembly, Installation, Vol 2	0166 00
Mechanical Transmission Lubrication Oil Low Pressure Switch Replacement Removal, Installation, Vol 2	0167 00
Transmission Oil Pressure Sending Unit, Oil Temperature Sending Unit and Switch Replacement Removal, Installation, Vol 2	0168 00
External Vehicle Warning Horn Maintenance Removal, Disassembly, Assembly, Installation, Vol 2	0169 00
Powerplant Warning Horn Maintenance Removal, Disassembly, Assembly, Installation, Vol 2	0170 00
Engine Oil Temperature Sending Unit, Engine Oil Pressure Sending Unit, and Switches Replacement Removal, Installation, Vol 2	0171 00
Stoplight Switch Replacement Removal, Installation, Vol 2	0172 00
Rigger’s Service Light Switch Replacement Removal, Installation, Vol 2	0173 00
Driver’s Headlight Dimmer Switch and Mounting Bracket Replacement Removal, Installation, Vol 2	0174 00
Front Headlight Assembly Maintenance Removal, Disassembly, Assembly, Installation, Vol 2	0175 00
Repair Rigger’s Service Light Maintenance Removal, Disassembly, Assembly, Installation, Vol 2	0176 00
Front Signal Light Assembly Maintenance Removal, Disassembly, Assembly, Installation, Vol 2	0177 00
Spare Headlight Mount Base Assembly Replacement Removal, Installation, Vol 2	0178 00
Stoplight-Taillight Assemblies Maintenance Removal, Disassembly, Assembly, Installation, Vol 2	0179 00
Troublelight Assembly Replacement Removal, Installation, Vol 2	0180 00
Rigger’s Fixed Spotlight and Related Parts Maintenance Removal, Disassembly, Assembly, Installation, Vol 2	0181 00
High Beam Indicator Light Assembly Maintenance Removal, Disassembly, Assembly, Installation, Vol 2	0182 00
Dome Light Maintenance Removal, Disassembly, Assembly, Installation, Vol 2	0183 00
Winch Illumination Lamp Assembly Maintenance Removal, Disassembly, Assembly, Installation, Vol 2	0184 00
Generator Power Lead Assembly (11671357) Maintenance Removal, Disassembly, Assembly, Installation, Vol 2	0185 00
Master Relay to Rectifier Lead Assembly (Single Voltage) (10866904) Maintenance Removal, Disassembly, Assembly, Installation, Vol 2	0186 00
Battery to Circuit Breaker Lead Assembly (11671811) Maintenance Removal, Disassembly, Assembly, Installation, Vol 2	0187 00
Starter Lead Assembly (10887570) Maintenance Removal, Disassembly, Assembly, Installation, Vol 2	0188 00

TABLE OF CONTENTS—Continued

	<u>WP Sequence No.</u>
Module Starter Wiring Harness (11671792) Maintenance Removal, Disassembly, Assembly, Installation, Vol 2.....	0189 00
Batteries to Master Relay, Voltage Regulators, Slave Receptacle, and Engine Disconnect Wiring Harness (Dual Voltage) (11672413) Maintenance Removal, Disassembly, Assembly, Installation, Vol 2.....	0190 00
Batteries to Master Relay, Voltage Regulators, Slave Receptacle, and Engine Disconnect Wiring Harness (Single Voltage) (11671791) Maintenance Removal, Disassembly, Assembly, Installation, Vol 2.....	0191 00
Engine Voltage Regulator to Engine Disconnect Wiring Harness (Dual Voltage) (11672415) Maintenance Removal, Assembly, Disassembly, Installation, Vol 2.....	0192 00
Gage Panel Wiring Harness (12322586) Maintenance Removal, Disassembly, Assembly, Installation, Vol 2.....	0193 00
Gage Panel to Bulkhead Wiring Harness (Dual Voltage) (12322587) Maintenance Removal, Disassembly, Assembly, Installation, Vol 2.....	0194 00
Gage Panel to Bulkhead Wiring Harness (Single Voltage) (11671807) Maintenance Removal, Disassembly, Assembly, Installation, Vol 2.....	0195 00
Electrical Accessories Panel Wiring Harness (10944744) Maintenance Removal, Disassembly, Assembly, Installation, Vol 2.....	0196 00
Flasher System Panel Wiring Harness (11672373) Maintenance Removal, Disassembly, Assembly, Installation, Vol 2.....	0197 00
Fuel Shutoff Switch Panel Lead Assembly (11671227-2) Maintenance Removal, Disassembly, Assembly, Installation, Vol 2.....	0198 00
Fuel Pump Switch Panel Lead Assembly (11671227-3) Maintenance Removal, Disassembly, Assembly, Installation, Vol 2.....	0199 00
Fuel Gage Panel Lead Assembly (10866881) Maintenance Removal, Disassembly, Assembly, Installation, Vol 2.....	0200 00
Switch Panel to Headlights and Bulkhead Wiring Harness (11671568) Maintenance Removal, Disassembly, Assembly, Installation, Vol 2.....	0201 00
Switch Panel, Radio, and Bilge Pump to Bulkhead Wiring Harness (11671798) Maintenance Removal, Disassembly, Assembly, Installation, Vol 2.....	0202 00
Switch Panel to Neutral Safety to Bulkhead Wiring Harness (11671420) Maintenance Removal, Disassembly, Assembly, Installation, Vol 2.....	0203 00
Switch Panel to Gage Panel and Miscellaneous Switches Wiring Harness (Passive Night Viewer) (Dual Voltage) (12322547) Maintenance Removal, Disassembly, Assembly, Installation, Vol 2.....	0204 00
Switch Panel to Gage Panel and Miscellaneous Switches Wiring Harness (Infrared Night Viewer) (Single Voltage) (11671795) Maintenance Removal, Disassembly, Assembly, Installation, Vol 2.....	0205 00
Starter Switch Wiring Harness (11671226) Maintenance Removal, Disassembly, Assembly, Installation, Vol 2.....	0206 00
Engine Wiring Harness (Dual Voltage) (11672416) Maintenance Removal, Disassembly, Assembly, Installation, Vol 2.....	0207 00
Engine Wiring Harness (Single Voltage) (11671816) Maintenance Removal, Disassembly, Assembly, Installation, Vol 2.....	0208 00
Engine Disconnect to Pressure Switch Wiring Harness (12314651) Maintenance Removal, Disassembly, Assembly, Installation, Vol 2.....	0209 00
Engine Disconnect to Starter Wiring Harness (Dual Voltage) (12314745) Maintenance Removal, Disassembly, Assembly, Installation, Vol 2.....	0210 00
Engine Disconnect to Engine Generator Relay Lead (Single Voltage) (11671362) Maintenance Removal, Disassembly, Assembly, Installation, Vol 2.....	0211 00

TABLE OF CONTENTS—Continued

	<u>WP Sequence No.</u>
Engine Disconnect Ground Lead Assembly (12322589) Maintenance Removal, Disassembly, Assembly, Installation, Vol 2.....	0212 00
Headlight Base Wiring Harness and Related Parts (7972352) Maintenance Removal, Disassembly, Assembly, Installation, Vol 2.....	0213 00
Headlight and Dimmer Switch Wiring Harness (10866950) Maintenance Removal, Disassembly, Assembly, Installation, Vol 2.....	0214 00
Red Flasher Breaker to Switch Wiring Harness (11672371) Maintenance Removal, Disassembly, Assembly, Installation, Vol 2.....	0215 00
Turn Signal Flasher Wiring Harness (11672273) Maintenance Removal, Disassembly, Assembly, Installation, Vol 2.....	0216 00
B.O. Selector Lead Assembly (10911920) Maintenance Removal, Disassembly, Assembly, Installation, Vol 2.....	0217 00
Main Lighting and B.O. Selector Switch Wiring Harness (11671796) Maintenance Removal, Disassembly, Assembly, Installation, Vol 2.....	0218 00
Main Lighting and Master Relay Wiring Harness (10866909) Maintenance Removal, Disassembly, Assembly, Installation, Vol 2.....	0219 00
Bulkhead to Master Relay and Left and Right Taillight Wiring Harness (11671813) Maintenance Removal, Disassembly, Assembly, Installation, Vol 2.....	0220 00
Bulkhead to Engine Wiring Harness and Starter Relay Wiring Harness (11671790) Maintenance Removal, Disassembly, Assembly, Installation, Vol 2.....	0221 00
Bulkhead to Engine Bracket and Rear Fuel Tank Transmitter Wiring Harness (Dual Voltage) (12322588) Maintenance Removal, Disassembly, Assembly, Installation, Vol 2.....	0222 00
Bulkhead to Engine Bracket and Rear Fuel Tank Transmitter Wiring Harness (Single Voltage) (11671789) Maintenance Removal, Disassembly, Assembly, Installation, Vol 2.....	0223 00
Bulkhead to APU, Master Relay, and Rigger’s Lights Wiring Harness (Dual Voltage) (11672412) Maintenance Removal, Disassembly, Assembly, Installation, Vol 2.....	0224 00
Bulkhead to APU, Master Relay, and Rigger’s Lights Wiring Harness (Single Voltage) (11671324) Maintenance Removal, Disassembly, Assembly, Installation, Vol 2.....	0225 00
Bulkhead Rear Slave Receptacle Wiring Harness (10894850-4) Maintenance Removal, Disassembly, Assembly, Installation, Vol 2.....	0226 00
APU Wiring Harness (11672417) Maintenance Removal, Disassembly, Assembly, Installation, Vol 2.....	0227 00
APU Control Box to Foot Dimmer Switch and Bulkhead Wiring Harness (Dual Voltage) (11672466) Maintenance Removal, Disassembly, Assembly, Installation, Vol 2.....	0228 00
APU Control Box to Foot Dimmer Switch and Bulkhead Wiring Harness (Single Voltage) (11671799) Maintenance Removal, Disassembly, Assembly, Installation, Vol 2.....	0229 00
APU and Engine Generator Relays to Voltage Regulator Wiring Harness (Single Voltage) (11671793) Maintenance Removal, Disassembly, Assembly, Installation, Vol 2.....	0230 00
Air Cleaner Circuit Breaker Lead Assembly (11671794) Maintenance Removal, Disassembly, Assembly, Installation, Vol 2.....	0231 00
Bilge Pump and Generator Cutout Switch Lead (10945007) Maintenance Removal, Disassembly, Assembly, Installation, Vol 2.....	0232 00
Bilge Pump Main Power Wiring Harness (10945008) Maintenance Removal, Disassembly, Assembly, Installation, Vol 2.....	0233 00
Bilge Pump Circuit Breaker to Switch Panel Lead (10894546) Maintenance Removal, Disassembly, Assembly, Installation, Vol 2.....	0234 00
Bilge Pump Lead Relay Wiring Harness and Cap (10894548) Maintenance Removal, Disassembly, Assembly, Installation, Vol 2.....	0235 00

TABLE OF CONTENTS—Continued

	<u>WP Sequence No.</u>
Heater Control Box to Heater Wiring Harness (11671353) Maintenance Removal, Disassembly, Assembly, Installation, Vol 2.....	0236 00
Hydraulic Oil Temperature Transmitter Housing Assembly Wiring Harness (11672366) Maintenance Removal, Disassembly, Assembly, Installation, Vol 2.....	0237 00
Diode Lead Assembly (12322604) Maintenance Removal, Disassembly, Assembly, Installation, Vol 2.....	0238 00
Engine Disconnect to Starter Ground Wiring Harness (Single Voltage) (11671356) Maintenance Removal, Disassembly, Assembly, Installation, Vol 2.....	0239 00
M239 Smoke Grenade Launcher System Wiring Harness (Single Voltage) (11672299) Maintenance Removal, Disassembly, Assembly, Installation, Vol 2.....	0240 00
Power Switch Box Assembly for M239 Smoke Grenade Launcher Wiring Harness (11672315) Maintenance Removal, Disassembly, Assembly, Installation, Vol 2.....	0241 00
Driver’s Vehicle Exhaust Smoke Bracket to Bulkhead Connection Wiring Harness (11672382) Maintenance Removal, Disassembly, Assembly, Installation, Vol 2.....	0242 00
Commander’s Switch Plate to Driver’s Vehicle Exhaust Smoke Bracket (11372387) Maintenance Removal, Disassembly, Assembly, Installation, Vol 2.....	0243 00
Fuel Solenoid Wiring Harness (11672386) Maintenance Removal, Disassembly, Assembly, Installation, Vol 2.....	0244 00
Fuel/Water Separator Control Module to Solenoid Drain Valve Wiring Harness (11684127) Maintenance Removal, Disassembly, Assembly, Installation, Vol 2.....	0245 00
Exhaust Smoke Generating System Lead Assembly (11672385) Maintenance Removal, Disassembly, Assembly, Installation, Vol 2.....	0246 00
Smoke Generating System Lead Assembly (11672473-1) Maintenance Removal, Disassembly, Assembly, Installation, Vol 2.....	0247 00
Smoke Generating System Lead Assembly (11672473-2) Maintenance Removal, Disassembly, Assembly, Installation, Vol 2.....	0248 00
Driver’s Periscope to Infrared Power Supply (Single Voltage) (10866967) Maintenance Removal, Disassembly, Assembly, Installation, Vol 2.....	0249 00
Ventilator Blower Assembly Replacement Removal, Installation, Vol 2.....	0250 00
Bilge Pump Power Lead Relay, Mounting Plate, and Circuit Breaker Replacement Removal, Installation, Vol 2.....	0251 00
Fuel Injection Pump, Fuel Shutoff Solenoid, Lead, and Related Parts Replacement Removal, Installation, Vol 2.....	0252 00
Dummy Connector Assembly (Infrared and Passive Night Viewer) Replacement Removal, Installation, Vol 2.....	0253 00
Electrical Kit for M239 Smoke Grenade Launcher Discharger Feed Through Cable Assemblies (11672298-1 and 11672298-2) Replacement Removal, Installation, Vol 2.....	0254 00
Cable, Wire, Receptacle, and Plug Identifier Repair, Vol 2.....	0255 00
Terminal-Type Cable Connector Repair, Vol 2.....	0256 00
Male Cable Connector Repair, Vol 2.....	0257 00
Female Cable Connector (with Sleeve) Repair, Vol 2.....	0258 00
Typical Female-Type Panel Mounting Receptacle Repair Disassembly, Assembly, Vol 2.....	0259 00
Typical Male-Type Panel Mounting Receptacle Repair Disassembly, Assembly, Vol 2.....	0260 00
Typical Female-Type Panel Mounting Receptacle (with Ridged Locking Nut) Repair Disassembly, Assembly, Vol 2.....	0261 00
Typical Male-Type Panel Mounting Receptacle (with Ridged Locking Nut) Repair Disassembly, Assembly, Vol 2.....	0262 00
Typical Female-Type Plug Repair Disassembly, Assembly, Vol 2.....	0263 00
Typical Male-Type Plug Repair Disassembly, Assembly, Vol 2.....	0264 00

TABLE OF CONTENTS—Continued

	<u>WP Sequence No.</u>
CHAPTER 8 – UNIT MAINTENANCE INSTRUCTIONS, VOL 2	
Transmission Actuating Brake Air Valve Linkage Maintenance Removal, Installation, Adjustment, Vol 2.....	0265 00
Transmission Oil Filter Maintenance Removal, Service, Installation, Vol 2.....	0266 00
Transmission Roller Bracket Assembly Replacement Removal, Installation, Vol 2.....	0267 00
Transmission Torque Converter Drain Plugs Replacement Removal, Installation, Vol 2.....	0268 00
Transmission Gage Rod Replacement Removal, Installation, Vol 2.....	0269 00
Transmission Breather Assembly and Line Replacement Removal, Installation, Vol 2.....	0270 00
Transmission Oil Cooler Lines and Sampling Valve Replacement Removal, Installation, Vol 2.....	0271 00
Transmission Saddle Seals Replacement Removal, Installation, Vol 2.....	0272 00
Transmission Output Reduction Drives and Drive Couplings Replacement Removal, Installation, Vol 2.....	0273 00
CHAPTER 9 – UNIT MAINTENANCE INSTRUCTIONS, VOL 2	
Roadwheel Replacement Removal, Installation, Vol 2.....	0274 00
Torsion Bar and Torsion Bar Anchors Replacement Removal, Installation, Vol 2.....	0275 00
Roadwheel Arm Assembly Replacement Removal, Installation, Vol 2.....	0276 00
Roadwheel Hub Assembly Maintenance Removal, Cleaning, Inspection, Installation, Vol 2.....	0277 00
Roadwheel Support Housing Replacement Removal, Installation, Vol 2.....	0278 00
Track Support Roller, Bracket, and Wheel Maintenance Removal, Disassembly, Cleaning, Inspection, Assembly, Installation, Vol 2.....	0279 00
Left Front Track Support Roller, Bracket, and Wheel Maintenance Removal, Disassembly, Cleaning, Inspection, Assembly, Installation, Vol 2.....	0280 00
Compensating Idler Arm Assembly Wheels, Hub Assembly, Links, and Link Bearings Replacement Removal, Installation, Vol 2.....	0281 00
Compensating Idler and Arm Assembly Maintenance Removal, Cleaning, Inspection, Installation, Vol 2.....	0282 00
Final Drive Sprocket and Hub Replacement Removal, Installation, Vol 2.....	0283 00
Bumper Springs and Brackets Maintenance Removal, Disassembly, Assembly, Installation, Vol 2.....	0284 00
Shock Absorbers Replacement Removal, Installation, Vol 2.....	0285 00
CHAPTER 10 – UNIT MAINTENANCE INSTRUCTIONS, VOL 2	
Right-Front Access Floor Plate Replacement Removal, Installation, Vol 2.....	0286 00
Right-Front Floor Plate Rear Access Replacement Removal, Installation, Vol 2.....	0287 00
Hydraulic Valve Forward Right Floor Plate Replacement Removal, Installation, Vol 2.....	0288 00
U-35 Winch Center Right Floor Plate Replacement Removal, Installation, Vol 2.....	0289 00
Intermediate Rear Right Floor Plate Replacement Removal, Installation, Vol 2.....	0290 00
Rear Right-Side Floor Plate Replacement Removal, Installation, Vol 2.....	0291 00
Hydraulic Connections Access Cover Replacement Removal, Installation, Vol 2.....	0292 00
Rear Intermediate Right Floor Plate Replacement Removal, Installation, Vol 2.....	0293 00
Rear Intermediate Right Access Cover Replacement Removal, Installation, Vol 2.....	0294 00
Rear Intermediate Right Access Floor Plate Replacement Replacement, Installation, Vol 2.....	0295 00
Hydraulic Line Intermediate Rear Right Center Floor Plate Replacement Removal, Installation, Vol 2.....	0296 00
Rear Center Floor Plate Maintenance Removal, Disassembly, Assembly, Installation, Vol 2.....	0297 00
Rear Left-Side Intermediate Floor Plate Replacement Removal, Installation, Vol 2.....	0298 00
Fuel Transmitter Center Left Floor Access Plate Replacement Removal, Installation, Vol 2.....	0299 00
Rear Left-Side Floor Plate Replacement Removal, Installation, Vol 2.....	0300 00

TABLE OF CONTENTS—Continued

	<u>WP Sequence No.</u>
Intermediate Rear Left-Side Floor Plate Replacement Removal, Installation, Vol 2.....	0301 00
Intermediate Rear Left-Center Floor Plate Replacement Removal, Installation, Vol 2.....	0302 00
Center Rear Floor Plate Replacement Removal, Installation, Vol 2.....	0303 00
Center Forward Floor Plate Replacement Removal, Installation, Vol 2.....	0304 00
Intermediate Rear Left Access Floor Plate Replacement Removal, Installation, Vol 2.....	0305 00
Stowage Basket Forward Intermediate Left Floor Plate Maintenance Removal, Disassembly, Assembly, Installation, Vol 2.....	0306 00
Floor and Light Mount Plate Maintenance Removal, Disassembly, Assembly, Installation, Vol 2.....	0307 00
Hydraulic Valve Forward Intermediate Right Floor Plate Replacement Removal, Installation, Vol 2.....	0308 00
Front Subfloor Support Replacement Removal, Installation, Vol 2.....	0309 00
Center and Rear Subfloor Support Replacement Removal, Installation, Vol 2.....	0310 00
Fenders and Related Parts Replacement Removal, Installation, Vol 2.....	0311 00
Commander’s Cupola Assembly Maintenance Removal, Disassembly, Assembly, Installation, Vol 2.....	0312 00
Driver’s Cab-Top Door and Related Parts Maintenance Removal, Disassembly, Assembly, Installation, Vol 2.....	0313 00
Mechanic’s Cab-Top Door and Related Parts Maintenance Removal, Disassembly, Assembly, Installation, Vol 2.....	0314 00
Rigger’s Cab-Top Door and Related Parts Maintenance Removal, Disassembly, Assembly, Installation, Vol 2.....	0315 00
Wire Rope Roller Access Door Replacement Removal, Installation, Vol 2.....	0316 00
Left and Right Stowage Compartment Doors Replacement Removal, Installation, Vol 2.....	0317 00
Left and Right Personnel Doors Replacement Removal, Installation, Vol 2.....	0318 00
Fuel Tank Filler Access Cover Replacement Replacement, Installation, Vol 2.....	0319 00
Bilge Pump Outlet Cover Replacement Removal, Installation, Vol 2.....	0320 00
Left- and Right-Side Air Cleaner Inlet Covers Replacement Removal, Installation, Vol 2.....	0321 00
Left and Right Personnel Step Assemblies Replacement Removal, Installation, Vol 2.....	0322 00
Passive Night Viewer Mount and Related Parts Maintenance Removal, Disassembly, Assembly, Installation, Vol 2.....	0323 00
Infrared Power Supply Replacement Removal, Installation, Vol 2.....	0324 00
Periscope Quick-Release Mount (Infrared Night Viewer) Replacement Removal, Installation, Vol 2.....	0325 00
Driver’s and Rigger’s Periscope Blocks and Vision Prisms Replacement Removal, Installation, Vol 2.....	0326 00
Mechanic’s Periscope Block and Vision Prisms Replacement Removal, Installation, Vol 2.....	0327 00
Towing Pintle and Mount Maintenance Removal, Disassembly, Cleaning, Inspection, Assembly, Installation, Vol 2.....	0328 00
Boom Support and Related Parts Maintenance Removal, Installation, Adjustment, Vol 2.....	0329 00
Transmission Guide Bars Replacement Removal, Installation, Vol 2.....	0330 00
Antenna Base Covers Replacement Removal, Installation, Vol 2.....	0331 00
Acetylene Hose Adapter Replacement Removal, Installation, Vol 2.....	0332 00
Battery Tray Cleaning Tubes Replacement Removal, Installation, Vol 2.....	0333 00
APU Access Cover Assembly Replacement Removal, Installation, Vol 2.....	0334 00
APU Access Door Replacement Removal, Installation, Vol 2.....	0335 00
Engine Deck, Deck Base, and Related Parts Maintenance Removal, Disassembly, Assembly, Installation, Vol 2.....	0336 00
Right Engine Deck Door Maintenance Removal, Disassembly, Assembly, Installation, Vol 2.....	0337 00

TABLE OF CONTENTS—Continued

	<u>WP Sequence No.</u>
Clamp Assembly Replacement Removal, Installation, Vol 2.....	0338 00
Insulation Retainer Replacement Removal, Installation, Vol 2.....	0339 00
Engine Transmission Access Doors Maintenance Removal, Disassembly, Assembly, Installation, Vol 2.....	0340 00
Air Inlet Doors Replacement Removal, Installation, Vol 2.....	0341 00
Left- and Center-Front Air Inlet Grilles Replacement Removal, Installation, Vol 2.....	0342 00
Deep Water Fording Exhaust Cover Plates Replacement Removal, Installation, Vol 2.....	0343 00
Exhaust Deflector Replacement Removal, Installation, Vol 2.....	0344 00
Left and Right Deck Air Inlet Doors Replacement Removal, Installation, Vol 2.....	0345 00
Left and Right Exhaust Doors Replacement Removal, Installation, Vol 2.....	0346 00
Center Exhaust Doors Replacement Removal, Installation, Vol 2.....	0347 00
Nonslip Walkway Coating Service, Vol 2.....	0348 00
Personnel Seat Assemblies Maintenance Removal, Disassembly, Assembly, Installa- tion, Vol 2.....	0349 00
Commander’s Seat Assembly Maintenance Removal, Disassembly, Inspection, Repair, Assembly, Installation, Vol 2.....	0350 00
Rigger’s Seat Assembly Maintenance Removal, Disassembly, Inspection, Repair, Assem- bly, Installation, Vol 2.....	0351 00
Mechanic’s and Driver’s Seat Assemblies Maintenance Removal, Disassembly, Inspection, Repair, Assembly, Installation, Vol 2.....	0352 00
Drain Valves Maintenance Removal, Disassembly, Inspection, Assembly, Installa- tion, Vol 2.....	0353 00
Drain Valve Controls Maintenance Removal, Inspection, Repair, Installation, Vol 2.....	0354 00
Drain Covers Replacement Removal, Installation, Vol 2.....	0355 00
Mechanical Tachometer and Speedometer Flexible Shafts and Fittings Maintenance Removal, Cleaning, Inspection, Installation, Vol 2.....	0356 00
Steering Controls and Linkages Maintenance Removal, Disassembly, Assembly, Installa- tion, Vol 2.....	0357 00
Steering Controls and Linkages Alignment, Vol 2.....	0358 00
Steering Control Assembly Maintenance Removal, Disassembly, Assembly, Installa- tion, Vol 2.....	0359 00
Steering Control Housing Assembly Maintenance Removal, Disassembly, Assembly, Installation, Vol 2.....	0360 00
Shifting Controls and Linkages Maintenance Removal, Disassembly, Assembly, Installa- tion, Vol 2.....	0361 00
Shifting Controls and Linkages Alignment Alignment, Adjustment, Vol 2.....	0362 00
Accelerator Controls and Linkages Maintenance Removal, Disassembly, Cleaning, Inspec- tion, Repair, Assembly, Installation, Vol 2.....	0363 00
Accelerator Controls and Linkages Alignment Alignment, Adjustment, Vol 2.....	0364 00
Brake Controls and Linkages Maintenance Removal, Disassembly, Assembly, Installation, Alignment, Adjustment, Vol 2.....	0365 00
Brake Pedal and Bracket Assembly Maintenance Removal, Disassembly, Assembly, Installation, Vol 2.....	0366 00
Brake Cam Assembly Maintenance Removal, Disassembly, Assembly, Installation, Vol 2.....	0367 00
Bearing Unit Housing Assembly Maintenance Removal, Disassembly, Assembly, Installa- tion, Vol 2.....	0368 00
Plate Assembly Maintenance Removal, Disassembly, Assembly, Installation, Vol 2.....	0369 00
Lever Assembly Maintenance Disassembly, Assembly, Vol 2.....	0370 00
Linkage Roller Plates Replacement Removal, Installation, Vol 2.....	0371 00

TABLE OF CONTENTS—Continued

	<u>WP Sequence No.</u>
Vise Mounting Hardware and Adapter Plate Replacement Removal, Installation, Vol 2	0372 00
Decontamination Apparatus Bracket Assembly Replacement Removal, Installation, Vol 2.....	0373 00
Tow Bar Assembly, Tow Bar Mounting Brackets, and Tow Chain Mounting Brackets	
Maintenance Removal, Disassembly, Assembly, Installation, Vol 2.....	0374 00
Bracket Assemblies For Side Tow Bar and Side Tow Cables Maintenance Removal,	
Disassembly, Assembly, Installation, Vol 2	0375 00
Tarpaulin Tray Replacement Removal, Installation, Vol 2.....	0376 00
10-Ton Snatch Block and Track Link Retainers Replacement Removal, Installation, Vol 2.....	0377 00
25-Ton Snatch Block Retainer Replacement Removal, Installation, Vol 2.....	0378 00
Oxygen Tank Strap Assemblies Replacement Removal, Installation, Vol 2.....	0379 00
Pioneer Tool Set Bracket Maintenance Removal, Disassembly, Assembly, Installa-	
tion, Vol 2.....	0380 00
Roadwheel, Support Wheel, and Sprocket Attaching Hardware Replacement Removal,	
Installation, Vol 2.....	0381 00
Stowage Basket Replacement Removal, Installation, Vol 2.....	0382 00
Passive Night Viewer Stowage Box, Hand Grenade Boxes and Machine Gun and Rifle	
Holders Replacement Removal, Installation, Vol 2.....	0383 00
Hand Fire Extinguisher Brackets Replacement Removal, Installation, Vol 2.....	0384 00
Rocket Ammunition Stowage Box Assembly Replacement Removal, Installation, Vol 2.....	0385 00
Caliber .50 Ammunition Rack and Track Wrench Bracket Maintenance Removal, Disas-	
sembly, Assembly, Installation, Vol 2.....	0386 00
Acetylene and Compartment Door Hardware and Related Parts Replacement Removal,	
Installation, Vol 2.....	0387 00
Flasher Light Case Replacement Removal, Installation, Vol 2.....	0388 00
Toolbox Rack Replacement Removal, Installation, Vol 2.....	0389 00
Oddment Tray, Left Side Replacement Removal, Installation, Vol 2.....	0390 00
Caliber .50 Stowage Strap Replacement Removal, Installation, Vol 2.....	0391 00
Liquid Container Brackets Replacement Removal, Installation, Vol 2.....	0392 00
M72 LAW Rocket Launcher Brackets Maintenance Removal, Disassembly, Assembly,	
Installation, Vol 2.....	0393 00
Interior and Exterior Straps Replacement Removal, Installation, Vol 2.....	0394 00
Vehicle ID Plate Replacement Removal, Installation, Vol 2.....	0395 00
 CHAPTER 11 – UNIT MAINTENANCE INSTRUCTIONS, VOL 2	
Personnel Heater Replacement Removal, Installation, Vol 2.....	0396 00
Personnel Heater and APU Air Intake Water Deflector Replacement Removal, Installa-	
tion, Vol 2.....	0397 00
Personnel Heater Fuel Pump Replacement Removal, Installation, Vol 2.....	0398 00
Personnel Heater Fuel Filter Replacement Removal, Installation, Vol 2.....	0399 00
Fixed Fire Extinguisher Cylinders Maintenance Removal, Inspection, Installation, Vol 2.....	0400 00
Fixed Fire Extinguisher Cylinder Controls Maintenance Removal, Inspection, Installa-	
tion, Vol 2.....	0401 00
Fixed Fire Extinguisher System Controls and Linkages Maintenance Removal, Installation,	
Adjustment, Vol 2.....	0402 00
Fixed Fire Extinguisher System Lines and Nozzles Replacement Removal, Installa-	
tion, Vol 2.....	0403 00
 CHAPTER 12 – UNIT MAINTENANCE INSTRUCTIONS, VOL 2	
Main Winch Level Winder Cylinder Adjustment, Vol 2.....	0404 00
Main Winch Brake Band Adjustment, Vol 2.....	0405 00

TABLE OF CONTENTS—Continued

	<u>WP Sequence No.</u>
Main Winch Manual Control and Linkage Replacement Removal, Installation, Vol 2	0406 00
Main Winch Controls and Hoses Replacement Removal, Installation, Vol 2	0407 00
Main Winch Cable Replacement Removal, Installation, Vol 2	0408 00
Hoist Winch Hose and Cable Assembly Replacement Removal, Installation, Vol 2	0409 00
Hoist Winch Brake Band Adjustment, Vol 2	0410 00
Hoist Winch Manual Control and Linkage Replacement Removal, Installation, Vol 2	0411 00
Wire Rope Shield Replacement Removal, Installation, Vol 2	0412 00
Wire Rope Roller Housing and Bearing Maintenance Removal, Disassembly, Assembly, Installation, Vol 2	0413 00
Hoisting Boom, Cylinders, and Related Parts Maintenance Removal, Installation, Inspec- tion, Vol 2	0414 00
Stayline Cylinder Limit Valve Adjustment, Vol 2	0415 00
 CHAPTER 13 – UNIT MAINTENANCE INSTRUCTIONS, VOL 2	
Mechanical Transmission and Hydraulic Pump Hydraulic Lines and Fittings Replacement Removal, Installation, Vol 2	0416 00
Hydraulic Lines and Fittings Replacement Removal, Installation, Vol 2	0417 00
Hydraulic Connecting Panel Replacement Removal, Installation, Vol 2	0418 00
Fuel Transfer Pump and Flow Regulator Replacement Removal, Installation, Vol 2	0419 00
Hydraulic System Oil Filter Maintenance Removal, Disassembly, Assembly, Installa- tion, Vol 2	0420 00
External Hydraulic Reservoir Components Replacement Removal, Installation, Vol 2	0421 00
Hydraulic Drain Valve and Related Parts Replacement Removal, Installation, Vol 2	0422 00
Hydraulic Subplate ID Plate Replacement Removal, Installation, Vol 2	0423 00
Hydraulic Oil Reservoir Strainer Replacement Removal, Installation, Vol 2	0424 00
Oil Temperature Transmitter and Switch Housing Assembly Maintenance Removal, Disassembly, Assembly, Installation, Vol 2	0425 00
Mechanical Transmission ID Plate Replacement Removal, Installation, Vol 2	0426 00
Mechanical Transmission Breather and Oil Level Gage Maintenance Removal, Disassem- bly, Assembly, Installation, Vol 2	0427 00
Spade Release and Lubrication Line (Hydraulic Spade Release) Replacement Removal, Installation, Vol 2	0428 00
Spade Cable Lubrication Line (Manual Spade Release) Replacement Removal, Installa- tion, Vol 2	0429 00
Spade Release Lubrication Fitting Replacement Removal, Installation, Vol 2	0430 00
Spade Cylinder Hoses Replacement Removal, Installation, Vol 2	0431 00
 CHAPTER 14 – UNIT MAINTENANCE INSTRUCTIONS, VOL 2	
APU Pressure Switch Assembly Replacement Removal, Installation, Vol 2	0432 00
Engine Air Cleaner, Filter, and Air Intake Tubes Maintenance Removal, Service, Installa- tion, Vol 2	0433 00
APU Cooling Air Exhaust Replacement Removal, Installation, Vol 2	0434 00
APU Engine Crankcase Fill-and-Level ID Plate Replacement Removal, Installation, Vol 2	0435 00
APU Engine Fuel Filters Replacement Removal, Installation, Vol 2	0436 00
APU Engine Oil Filter Replacement Removal, Installation, Vol 2	0437 00
APU Control Box Maintenance Removal, Disassembly, Assembly, Installation, Vol 2	0438 00
 CHAPTER 15 – UNIT MAINTENANCE INSTRUCTIONS, VOL 2	
M8A3 Filter Unit System Maintenance Removal, Disassembly, Assembly, Installation, Test, Vol 2	0439 00

TABLE OF CONTENTS—Continued

	<u>WP Sequence No.</u>
M8A3 Filter Unit M2A2 Air Purifier Maintenance Removal, Disassembly, Assembly, Installation, Vol 2.....	0440 00
M8A3 Filter Unit Switch Assembly Maintenance Removal, Disassembly, Assembly, Installation, Vol 2.....	0441 00
CHAPTER 16 – UNIT MAINTENANCE INSTRUCTIONS, VOL 2	
M239 Launcher Power Switch Box Assembly Maintenance Removal, Disassembly, Assembly, Installation, Vol 2.....	0442 00
M239 Launcher Dischargers Replacement Removal, Installation, Vol 2.....	0443 00
M239 Launcher Stowage Boxes Replacement Removal, Installation, Vol 2.....	0444 00
CHAPTER 17 – UNIT MAINTENANCE INSTRUCTIONS, VOL 2	
Exhaust Smoke Generating System Solenoid Valve Assemblies and Bracket Replacement Removal, Installation, Vol 2.....	0445 00
Exhaust Smoke Generating System Fuel Tube Assemblies Replacement Removal, Installation, Vol 2.....	0446 00
Exhaust Smoke Generating System Fuel Shutoff Valve Assembly Replacement Removal, Installation, Vol 2.....	0447 00
Exhaust Smoke Generating System Driver’s Bracket and Switch Assembly Maintenance Removal, Disassembly, Assembly, Installation, Vol 2.....	0448 00
Exhaust Smoke Generating System Commander’s Plate and Switch Assembly Maintenance Removal, Disassembly, Assembly, Installation, Vol 2.....	0449 00
CHAPTER 18 – UNIT MAINTENANCE INSTRUCTIONS, VOL 2	
Stoptlight and Covers Maintenance Removal, Disassembly, Assembly, Installation, Vol 2.....	0450 00
Reflectors and Mounting Plates Replacement Removal, Installation, Vol 2.....	0451 00
Flasher Assembly and Related Parts Replacement Removal, Installation, Vol 2.....	0452 00
Directional Signal Control and Mount Assembly Replacement Removal, Installation, Vol 2.....	0453 00
Mirror and Mount Assemblies Replacement Removal, Installation, Vol 2.....	0454 00
Front Directional Signal Lamps and Related Parts Replacement Removal, Installation, Vol 2.....	0455 00
Directional Signal Control Wiring Harness (12322611) Maintenance Removal, Disassembly, Assembly, Installation, Vol 2.....	0456 00
Right Tail Lamp to Left Tail Lamp To Bulkhead Wiring Harness (12322613) Maintenance Removal, Disassembly, Assembly, Installation, Vol 2.....	0457 00
Flasher Wiring Harness (12322612) Maintenance Removal, Disassembly, Assembly, Installation, Vol 2.....	0458 00
Directional Signal Control to Bulkhead Wiring Harness (12322614) Maintenance Removal, Disassembly, Assembly, Installation, Vol 2.....	0459 00
Main Lighting Switch Panel Wire Assemblies (12322615-1 and 12322615-2) Maintenance Removal, Disassembly, Assembly, Installation, Vol 2.....	0460 00
Headlight Base Assembly to Headlight and Dimmer Switch Wiring Harness (12322668) Maintenance Removal, Disassembly, Assembly, Installation, Vol 2.....	0461 00
Directional Signal Wiring Harness (12322660) Maintenance Removal, Disassembly, Assembly, Installation, Vol 2.....	0462 00
Directional Signal/Directional Signal Lamp Wire Assemblies (12322648) Maintenance Removal, Disassembly, Assembly, Installation, Vol 2.....	0463 00
Directional Signal Lamp Wire Assembly (12322658) Maintenance Removal, Disassembly, Assembly, Installation, Vol 2.....	0464 00

TABLE OF CONTENTS—Continued

	<u>WP Sequence No.</u>
CHAPTER 19 – UNIT MAINTENANCE INSTRUCTIONS, VOL 2	
Pre-Installation Procedures, Vol 2.....	0465 00
APU Installation, Vol 2.....	0466 00
Engine Generator Cooling Exhaust Installation, Vol 2.....	0467 00
Engine Exhaust Pipe Supports Installation, Vol 2.....	0468 00
Engine Air Inlet Pipes Installation, Vol 2.....	0469 00
Fuel Tank Vent Installation, Vol 2.....	0470 00
Acetylene Vent Installation, Vol 2.....	0471 00
Crew Fan and Boom Boot Drain Shutoff Clamp Installation, Vol 2.....	0472 00
Bilge Pump Installation, Vol 2.....	0473 00
Fire Extinguisher Nozzles and Electrical Connections in Engine Compartment Installation, Vol 2.....	0474 00
Exterior Fire Extinguisher Remote Control, Vol 2.....	0475 00
Other Applications of Caulking Compound, Vol 2.....	0476 00
Armament Protection, Vol 2.....	0477 00
Sealing Inspection, Vol 2.....	0478 00
Operations During Deep Water Fording, Vol 2.....	0479 00
Operations After Deep Water Fording, Vol 2.....	0480 00
Service After Deep Water Fording, Vol 2.....	0481 00
CHAPTER 20 – UNIT MAINTENANCE INSTRUCTIONS, VOL 2	
Decal Markings Replacement Removal, Installation, Vol 2.....	0482 00
Preparation for Storage and Shipment, Vol 2.....	0483 00
Illustrated List of Manufactured Items, Vol 2.....	0484 00
Torque Limits, Vol 2.....	0485 00
CHAPTER 21 – UNIT SUPPORTING INFORMATION, VOL 2	
References, Vol 2.....	0486 00
Introduction to Maintenance Allocation Chart (MAC), Vol 2.....	0487 00
Maintenance Allocation Chart (MAC), Vol 2.....	0488 00
Expendable and Durable Items List, Vol 2.....	0489 00
Tool Identification List, Vol 2.....	0490 00
Mandatory Replacement Parts List, Vol 2.....	0491 00
INDEX.....	INDEX-1
FOLDOUTS.....	FO-1

HOW TO USE THIS MANUAL

MANUAL CONTENT

Overview

This manual contains unit maintenance instructions for the M88A1 Medium Full-Tracked Recovery Vehicle.

The front matter in this manual consists of general warnings, title block page, and table of contents.

The information contained in this manual is presented in chapters and Work Packages. Each chapter is divided into Work Packages (WPs) that cover general information, troubleshooting procedures, maintenance procedures, and other information for specific systems or components. Each WP starts on a right-hand page with a page number of 1. Page numbers consist of the WP number followed by a dash and another number. For example, "0014 00-7" means WP 0014 00, page 7.

At the end of this manual are an alphabetical index, schematics, DA Form 2028-2, and a metric conversion chart.

Chapters

Chapter 1 provides general information, equipment description, and theory of operation.

Chapter 2 provides the troubleshooting procedures.

Chapter 3 provides general unit maintenance instructions including service upon receipt, the PMCS, and lubrication.

Chapter 4 provides unit maintenance instructions for the powerplant.

Chapter 5 provides unit maintenance instructions for the fuel, air intake, and exhaust systems.

Chapter 6 provides unit maintenance instructions for the engine cooling system.

Chapter 7 provides unit maintenance instructions for the electrical systems and circuits.

Chapter 8 provides unit maintenance instructions for the transmission and output reduction drives.

Chapter 9 provides unit maintenance instructions for the suspension system.

Chapter 10 provides unit maintenance instructions for the hull- and cab-related components.

Chapter 11 provides unit maintenance instructions for the personnel heater and connection components, and fixed fire extinguisher system.

Chapter 12 provides unit maintenance instructions for main winch, hoist winch, and related components.

Chapter 13 provides unit maintenance instructions for the main hydraulic system.

Chapter 14 provides unit maintenance instructions for the Auxiliary Power Unit (APU).

Chapter 15 provides unit maintenance instructions for the M8A3 gas/particulate filter unit.

Chapter 16 provides unit maintenance instructions for the M239 smoke grenade launcher system.

Chapter 17 provides unit maintenance instructions for the exhaust smoke generating system.

Chapter 18 provides unit maintenance instructions for the USAREUR safety lighting modification kit.

Chapter 19 provides unit maintenance instructions for the deep water fording kit.

Chapter 20 provides supplementary maintenance instructions including decal markings replacement, preparation for storage and shipment, an illustrated list of manufactured items, and torque limits.

Chapter 21 provides supporting information including the titles of documents and publications referenced in this manual, the MAC and special tools list, an expendable and durable items list, a tool ID list, and a list of mandatory replacement parts.

Alphabetical Index

An index is located after the last WP in this manual that provides an alphabetical listing of information and components/assemblies contained in this manual.

Schematics

There are three schematics in the form of foldouts located at the end of this manual. One schematic for the hydraulic system and four for the electrical system (two schematics for the dual voltage system and two schematics for the single voltage system).

HOW TO USE THIS MANUAL—Continued

DA Form 2028-2

DA Form 2028-2 is used to report errors and to recommend improvements for the tasks in this manual.

Metric Conversion Chart

The metric conversion chart converts English measurements to metric equivalents. Measurements in this manual are provided in both English and metric units.

WARNINGS, CAUTIONS, AND NOTES

Warnings, cautions, and notes are provided throughout this manual. There are good reasons for every one of these notices:

WARNING

A warning is used to alert the user to hazardous operating and maintenance procedures, practices, or conditions that could result in injury or death. Warnings must be strictly observed.

CAUTION

A caution is used to alert the user to hazardous operating and maintenance procedures, practices, or conditions that could result in damage to, or destruction of, equipment or mission effectiveness. Cautions must be strictly observed.

NOTE

A note highlights an essential operating or maintenance procedure, condition, or statement.

Warnings and cautions appear immediately preceding the step to which they pertain. It is important to read and thoroughly understand the warnings and/or cautions before beginning maintenance. Notes may precede or follow the steps to which they pertain, depending on what makes the most sense.

INITIAL SETUPS

Before starting a task, you must obtain all the tools, supplies, and personnel listed in the initial setup. Be sure to read the task before performing the maintenance. If any other tasks are referenced, you must go to the initial setup page for each of those tasks to find out what tools, supplies, and personnel will be needed.

UNIT MAINTENANCE
RECOVERY VEHICLE, FULL TRACKED: MEDIUM, M88A1
NSN 2350-00-122-6826, EIC AQA

GENERAL INFORMATION

SCOPE

This Unit Maintenance technical manual is for your use in maintaining the M88A1, Full-Tracked, Medium, Recovery Vehicle (Figures 1 and 2). The M88A1 is designed for towing, hoisting, and winching; its purpose is to provide for battlefield recovery of medium and light combat vehicles.

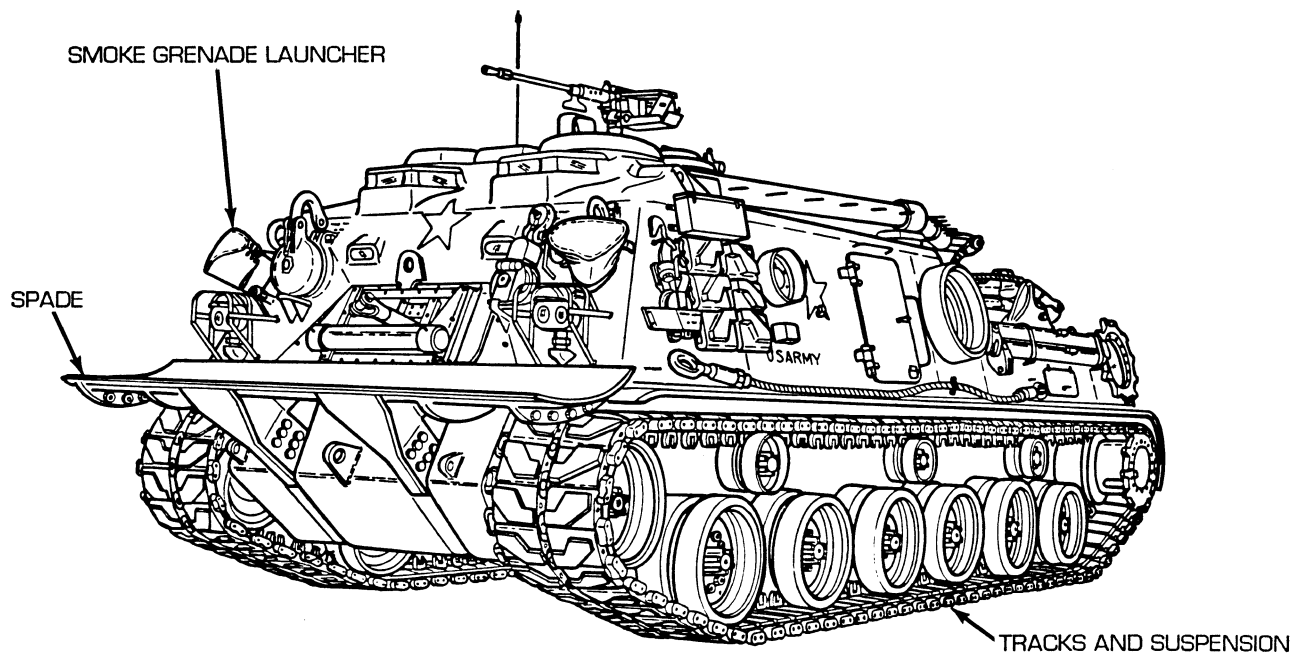

Figure 1. Recovery Vehicle, Full-Tracked: Medium, M88A1—Left-Front View.

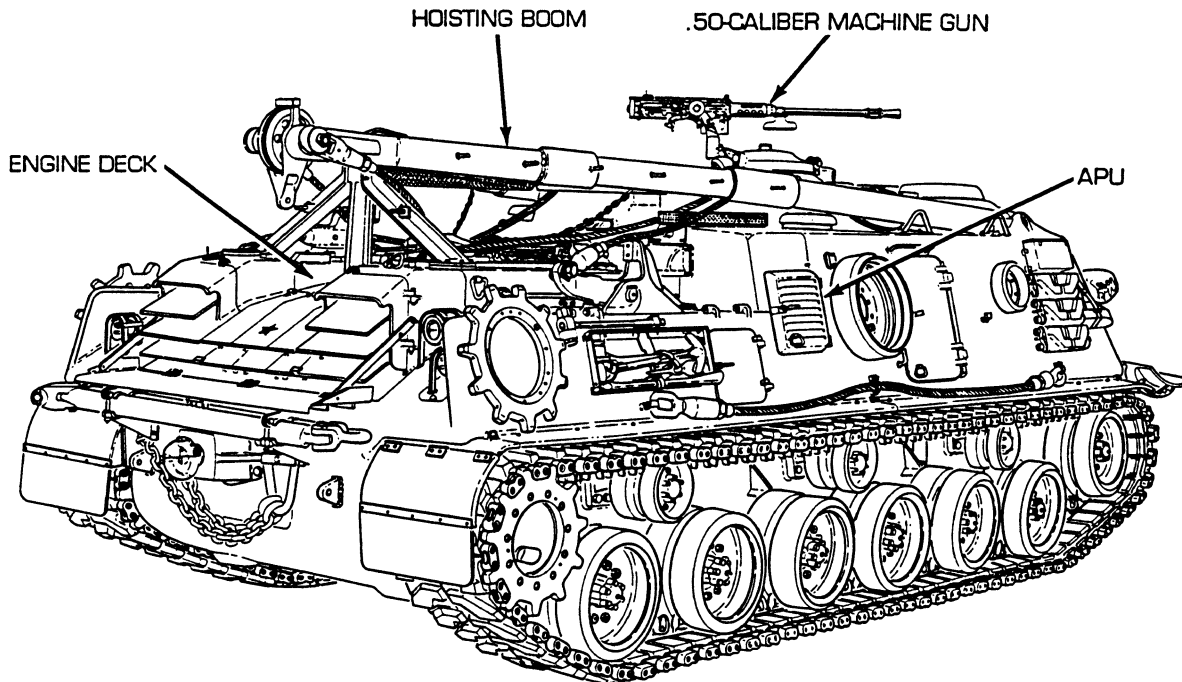

Figure 2. Recovery Vehicle, Full-Tracked: Medium, M88A1—Right Rear View.

MAINTENANCE FORMS, RECORDS, AND REPORTS

Department of the Army forms and procedures used for equipment maintenance will be those prescribed by (as applicable) DA PAM 738-750, Functional Users Manual for the Army Maintenance Management System (TAMMS); DA PAM 738-751, Functional Users Manual for the Army Maintenance Systems—Aviation (TAMMS-A); or AR 700-138, Army Logistics Readiness and Sustainability.

REPORTING EQUIPMENT IMPROVEMENT RECOMMENDATIONS (EIR)

If your M88A1 needs improvement, let us know. Send us an EIR. You, the user, are the only one who can tell us what you don't like about your equipment. Let us know why you don't like the design. Put it on an SF 368 (Product Quality Deficiency Report). Mail it to the address specified in DA PAM 738-750, Functional Users Manual for TAMMS, or as specified by the acquiring activity. We will send you a reply.

CORROSION PREVENTION AND CONTROL (CPC)

CPC of Army materiel is a continuing concern. It is important that any corrosion problems with this item be reported so that the problem can be corrected and improvements can be made to prevent the problem in future items.

While corrosion is typically associated with rusting of metals, it can also include deterioration of other materials, such as rubber and plastic. Unusual cracking, softening, swelling, or breaking of these materials may be a corrosion problem.

If a corrosion problem is identified, it can be reported using SF 368, Product Quality Deficiency Report. Use of key words such as "corrosion," "rust," "deterioration," or "cracking" will ensure that the information is identified as a CPC problem. The form should be submitted to the address specified in DA PAM 738-750, Functional Users Manual for TAMMS.

DESTRUCTION OF ARMY MATERIEL TO PREVENT ENEMY USE

For information and conditions under which destruction of the M88A1 should be undertaken to prevent enemy use and for other methods of destruction, refer to TM 9-2350-256-10 and TM 750-244-6.

PREPARATION FOR STORAGE OR SHIPMENT

The requirements for storage and shipment are covered in WP 0483 00.

NOMENCLATURE CROSS-REFERENCE

Throughout this manual, parts and component assemblies are referred to by their official nomenclature. In the following list, parts and component assemblies are identified by their official nomenclature followed by their common names.

Hexagonal Nut	Jamnut
Incandescent lamp	Bulb
Liquid level gage rod	Dipstick
Nonelectrical wire	Lockwire
Parking brake handle	Hand brake
Pipe plug	Drain plug
Quick-coupling half	Quick disconnect
Self-locking nut	Locknut
Self-locking washer	Lockwasher
Socket head screw key	Hex key
Spacer	Shim

LIST OF ABBREVIATIONS / ACRONYMS

Table 1. List of Abbreviations / Acronyms

BII	Basic Issue Items
cm	centimeters
CPC	Corrosion Prevention and Control
dc	direct current
DS	Direct Support
EIR	Equipment Improvement Recommendation
gal	gallons
GS	General Support
in.	inches
kg	kilograms
km/h	kilometers per hour
kPa	kilopascals
lb	pounds
lb-ft	pound-feet
MAC	Maintenance Allocation Chart
mm	millimeters
mph	miles per hour
NATO	North Atlantic Treaty Organization
NSN	National Stock Number

Table 1. List of Abbreviations / Acronyms—Continued

N•m	Newton-meters
P/N	part number
PMCS	Preventive Maintenance Checks and Services
psi	pounds per square inch
RPSTL	Repair Parts and Special Tools List
SC	Supply Catalog
SMR	Source, Maintenance, and Recoverability
TAMMS	The Army Maintenance Management System
TAMMS-A	The Army Maintenance Management System—Aviation
U/M	unit of measure
V	Volts
WP	Work Package

REPAIR PARTS, SPECIAL TOOLS, TMDE, AND SUPPORT EQUIPMENT

General

Tools, equipment, and repair parts are issued to Unit Maintenance personnel for maintaining the M88A1. Tools and equipment should not be used for purposes other than those prescribed. When not in use, these tools should be properly stowed in the spaces provided on the vehicle.

Common Tools and Equipment

For authorized common tools and equipment, refer to the Modified Table of Organization and Equipment (MTOE), CTA 50-970, Expendable/Durable Items (Except: Medical, Class V Repair Parts, and Heraldic Items), or CTA 8-100, Army Medical Department Expendable/Durable Items, as applicable to your unit.

Special Tools, TMDE, and Support Equipment

Certain tools and equipment, specially designed for Unit Maintenance, repair, and general use, are listed in WP 0488 00 for information only. This list is not to be used for requisitioning parts.

Repair Parts

Repair parts are listed and illustrated in the repair parts list (refer to TM 9-2350-256-24&P) covering Unit Maintenance for this equipment.

END OF WORK PACKAGE

CHAPTER 1
UNIT MAINTENANCE
INTRODUCTORY INFORMATION WITH THEORY OF OPERATION
FOR
RECOVERY VEHICLE, FULL TRACKED: MEDIUM, M88A1
(NSN: 2350-00-122-6826)

CHAPTER 1
UNIT MAINTENANCE
INTRODUCTORY INFORMATION WITH THEORY OF OPERATION

WORK PACKAGE INDEX

<u>Title</u>	<u>WP Sequence No.</u>
Equipment Description and Data.....	0002 00
Powerplant Theory of Operation.....	0003 00
Lubrication System Theory of Operation.....	0004 00
Fuel Supply, Air Intake, and Exhaust Systems Theory of Operation.....	0005 00
Manifold Air Induction Heater System Theory of Operation.....	0006 00
Cooling System Theory of Operation.....	0007 00
Electrical Systems and Circuits Theory of Operation.....	0008 00
Transmission and Output Reduction Drives Theory of Operation.....	0009 00
Tracks and Suspension Systems Theory of Operation.....	0010 00
Fixed Fire Extinguisher System Theory of Operation.....	0011 00
Winches, Spade Assembly, and Hoisting Boom Theory of Operation.....	0012 00
Mechanical Transmission and Main Hydraulic System Pump Theory of Operation.....	0013 00
Main Hydraulic System Theory of Operation.....	0014 00
Auxiliary Power Unit (APU) Theory of Operation.....	0015 00
M8A3 Gas/Particulate Filter Unit (GPFU) Theory of Operation.....	0016 00
M239 Smoke Grenade Launcher System Theory of Operation.....	0017 00
Exhaust Smoke Generating System Theory of Operation.....	0018 00
Deep Water Fording Kit Theory of Operation.....	0019 00
Radio Interference Suppression Theory of Operation.....	0020 00

UNIT MAINTENANCE
RECOVERY VEHICLE, FULL TRACKED: MEDIUM, M88A1
NSN 2350-00-122-6826, EIC AQA

EQUIPMENT DESCRIPTION AND DATA

EQUIPMENT CHARACTERISTICS, CAPABILITIES, AND FEATURES

General

The M88A1 is an armored vehicle used to perform battlefield recovery of medium and light combat vehicles. The vehicle is powered by a Continental, V-type, air-cooled, 12-cylinder, fuel-injected, turbosupercharged, diesel engine, model AVDS-1790-2DR, through an Allison cross-drive transmission, model XT-1410-4. The vehicle is designed for towing, hoisting, and winching. An armored, turret-type cupola with a caliber .50 machine gun is mounted on top of the vehicle cab. The vehicle is equipped with a hydraulically powered and controlled spade, hoisting boom, main winch, and hoist winch.

Racks, boxes, brackets, hangers, and straps are installed and conveniently located in and on the hull and cab. They provide stowage and supply facilities for various vehicular equipment such as water cans, tools, parts, wheels, sprockets, tarpaulins, track-connecting tools, and tow cables.

LOCATION AND DESCRIPTIONS OF MAJOR COMPONENTS

The components of the M88A1 that are essential to the operation and maintenance of the vehicle are shown in Figures 1 through 17.

External Components

General

1. Hoisting boom—a pivot-mounted, tubular A-frame which is raised or lowered by two hydraulically operated cylinders and supported by a stayline cable
2. Stowage doors—provide right- and left-side access
3. Auxiliary Power Unit (APU) door—provides exterior access to APU
4. Rigger's door—provides access from cab top; vision prisms located below door on hull rear
5. Personnel doors—provide right- and left-side access to cab
6. Commander's vision cupola—provides access and vision from cab top
7. Caliber .50 machine gun—an automatic, recoil-operated, linkbelt-fed, air-cooled, heavy-barrel type for Commander's use
8. Mechanic's door—provides access from right side of cab top; vision prisms located below door
9. Driver's door—provides access from left side of cab top; vision prisms located below door
10. M239 smoke grenade launcher—includes two smoke grenade dischargers, covers, and push button firing switch box
11. Spade—mounted to vehicle nosepiece by two trunnion-mounted arms; hydraulically activated
12. Tracks and suspension—includes transverse torsion-bar type suspension which, by means of individually suspended roadwheels that are supported by support arms splined to torsion bars, gives optimum riding characteristics over all types of terrain
13. Engine deck—rear top cover for engine/transmission

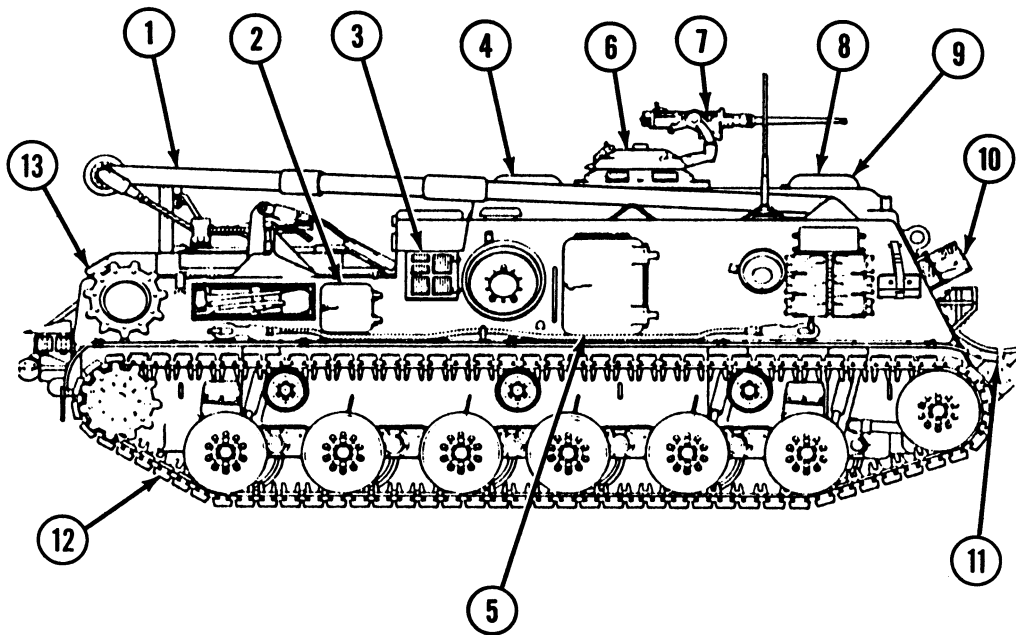

Figure 1. External Components.

External Components—Continued**Engine Deck—Schematic Diagram**

The following two illustrations are locator views of the engine deck and engine deck base associated with WP 0336 00 thru 0348 00.

1. Right engine deck door
2. Left- and center-front air inlet grilles
3. Deep water fording exhaust cover plates
4. Left and right exhaust doors
5. Center exhaust doors
6. Exhaust deflector
7. Left and right hydraulic cylinder access covers (see WP 0179 00)
8. Air inlet door
9. Left and right deck air inlet doors

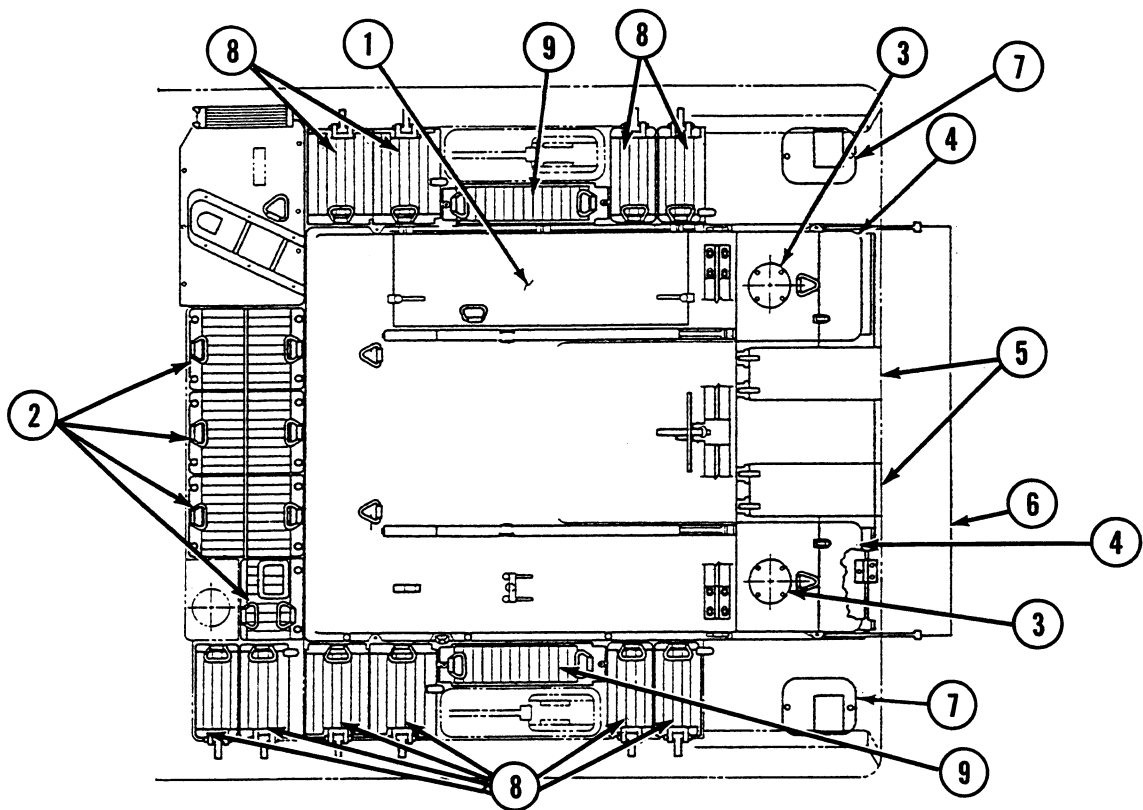

Figure 2. Engine Deck.

External Components--Continued

1. Deck base
2. Engine transmission access doors

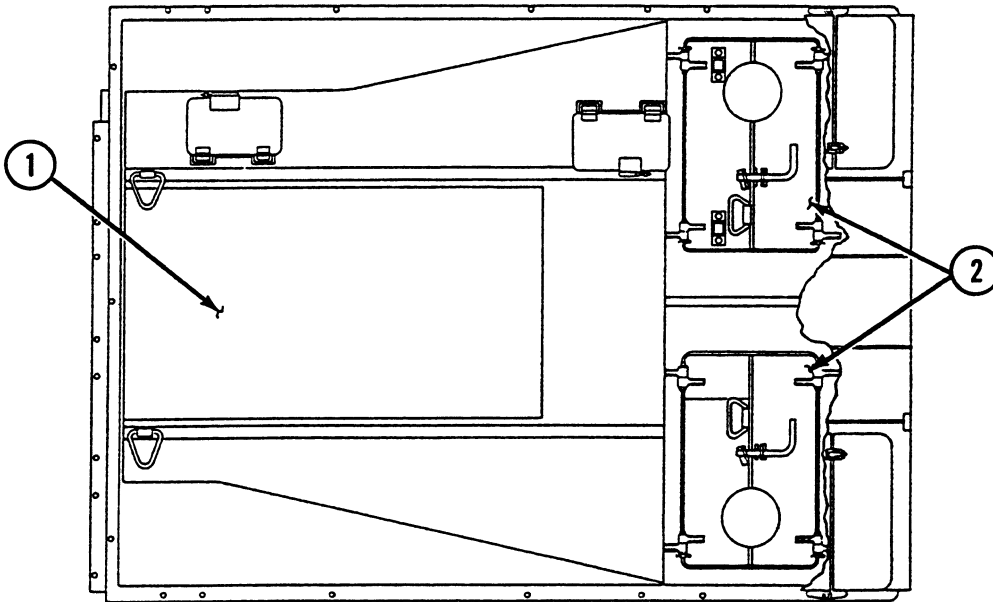

Figure 3. Engine Deck Base.

External Components—Continued**Hull and Cab—Schematic Diagram**

The following three illustrations are locator views for fenders and related parts replacement in addition to the left- and right-side hull and cab components associated with WP 0311 00 thru 0335 00.

1. Front fender (left- and right-side)
2. Fenders (four left-side and four right-side)
3. Splash guard (left- and right-side)
4. Hinged rear fender (left- and right-side)
5. Rear fender (left- and right-side)

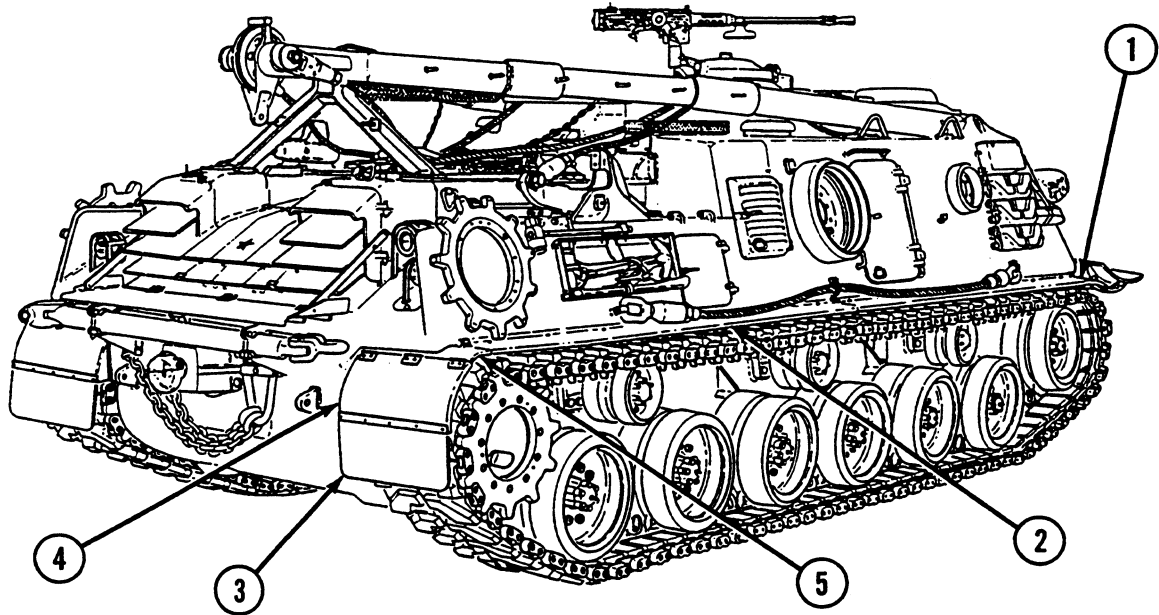

Figure 4. Fender ID.

External Components--Continued

1. Left personnel door
2. Driver's cab-top door
3. Commander's cupola
4. Left-side air cleaner inlet cover
5. Fuel tank filler access cover
6. Left stowage compartment door
7. Fender
8. Front fender
9. Wire rope roller access door

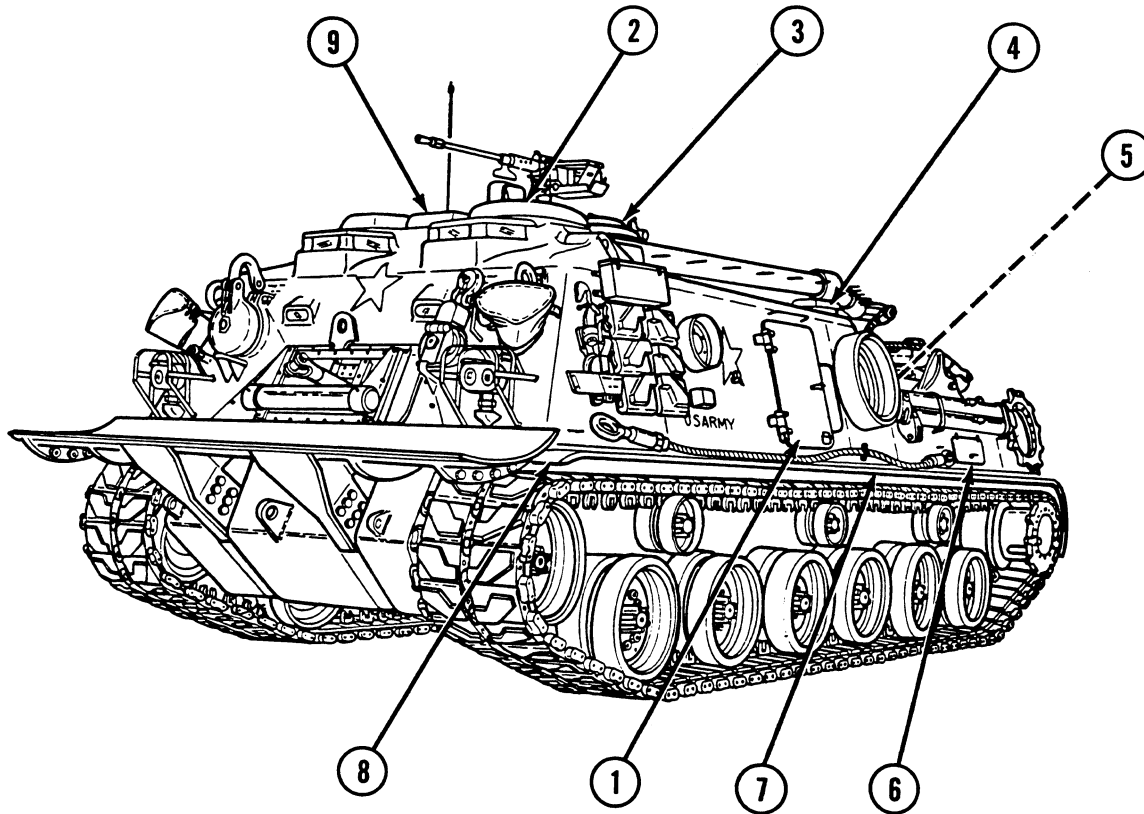

Figure 5. Left Side.

External Components--Continued

1. Rigger's cab-top door
2. Bilge pump outlet cover
3. Mechanic's cab-top door
4. Antenna base covers
5. Right-side air cleaner inlet cover
6. Right personnel door
7. APU access door
8. APU access cover
9. Right stowage compartment door
10. Rear fender
11. Engine deck
12. Towing pintle and mount
13. Boom support

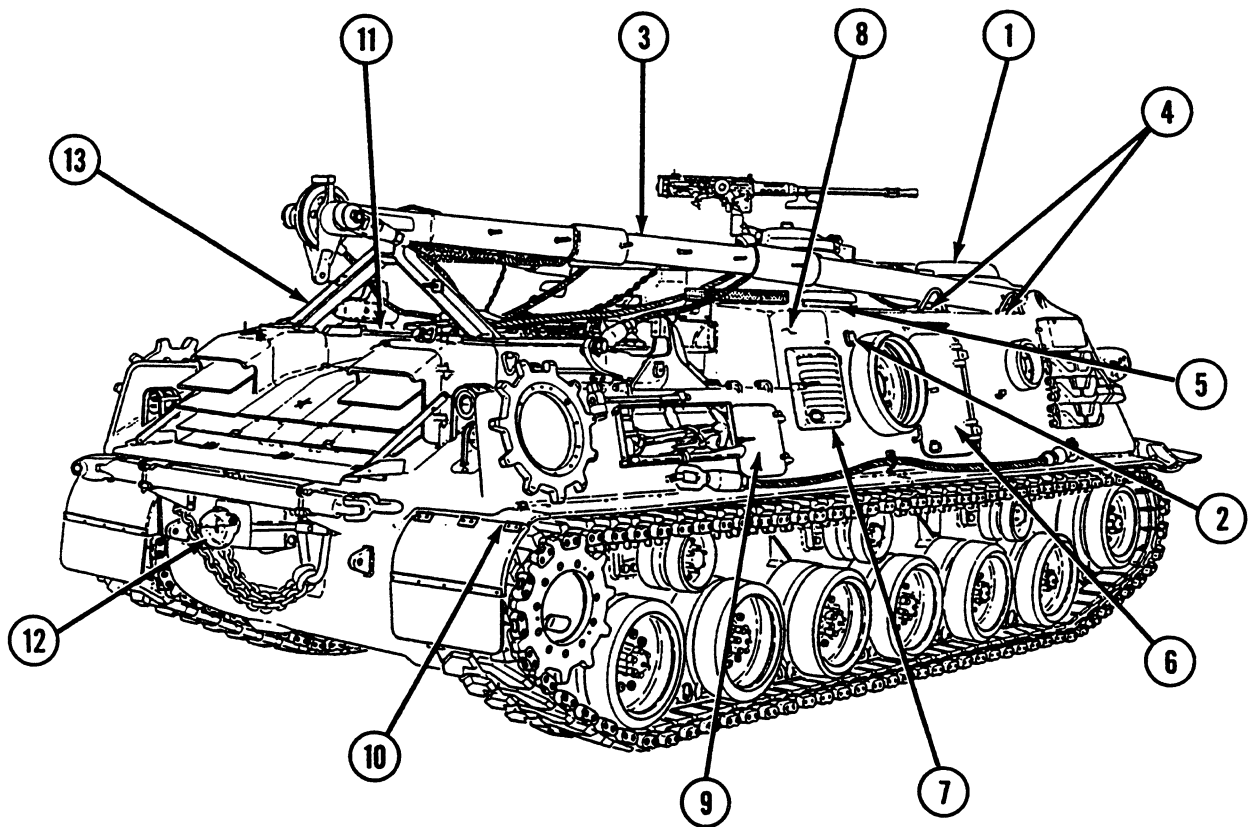

Figure 6. Right Side.

External Components—Continued**Stowage—Schematic Diagram**

The following three illustrations are locator views for exterior stowage components associated with WP 0372 00 thru 0381 00.

1. Oxygen tank strap assemblies
2. Tarpaulin tray
3. Crowbar straps
4. Vise adapter plate

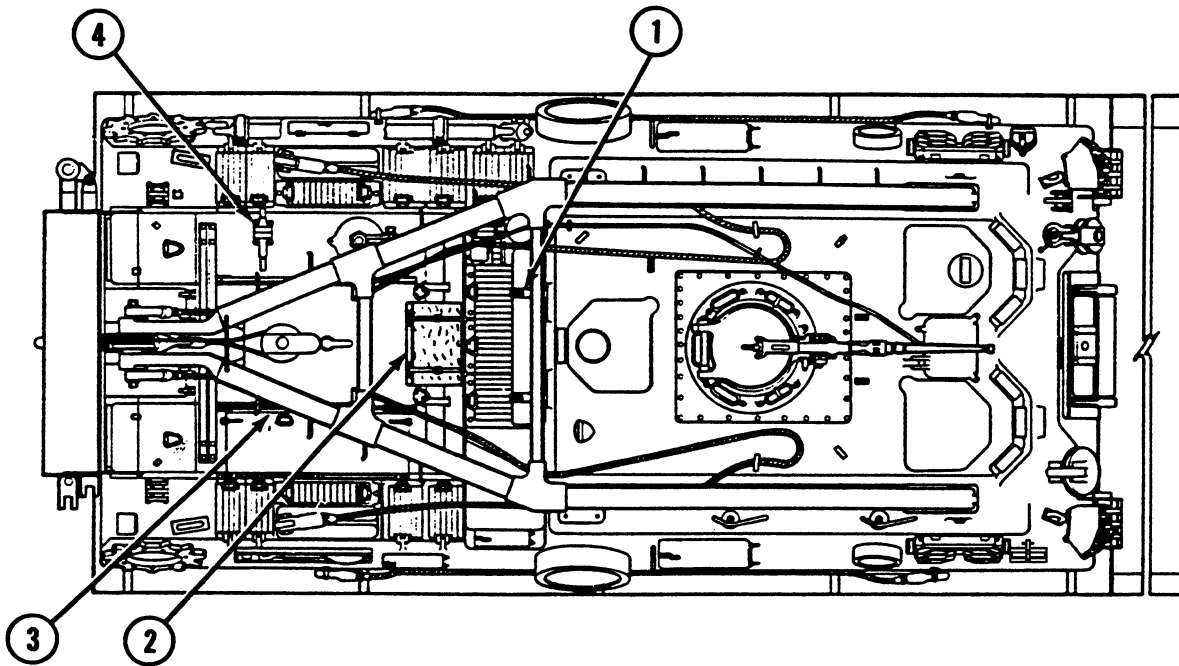

Figure 7. Top View.

External Components--Continued

1. 25-ton snatch block retainer
2. 10-ton snatch block retainer
3. Track link retainers (both sides)
4. Side tow bar bracket assemblies
5. Tow cable clamps (both sides)

NOTE

90-ton snatch block retainers are welded to hull.

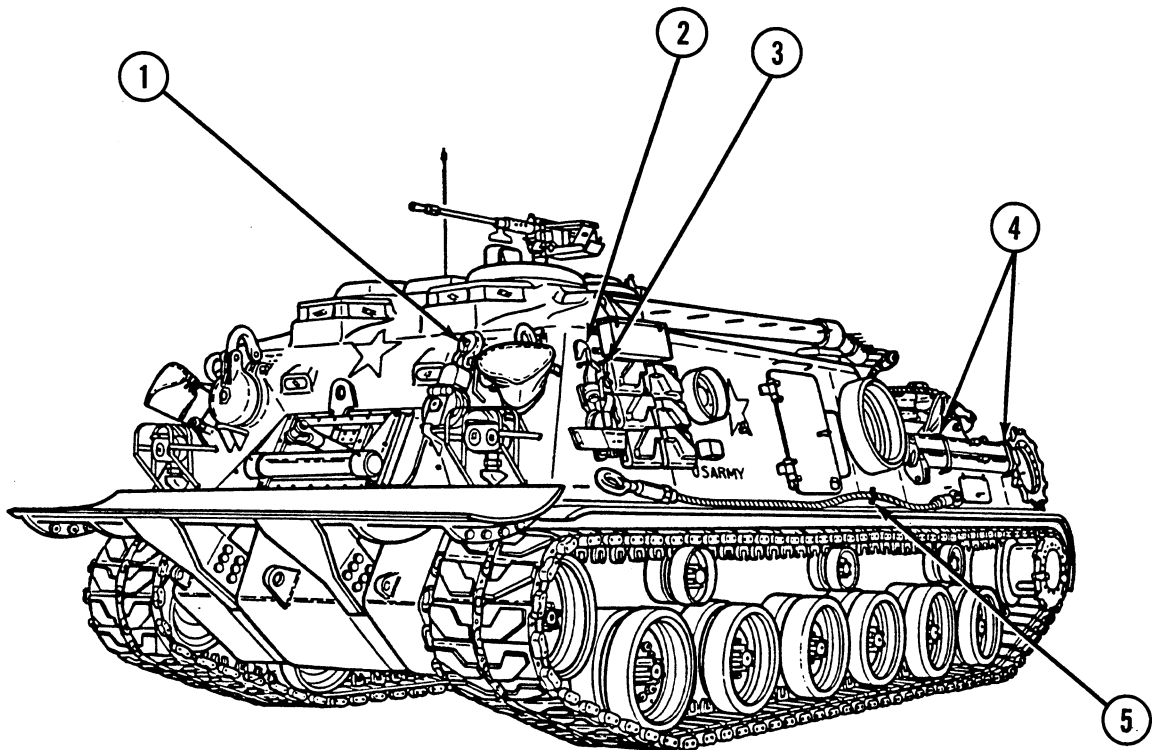

Figure 8. Left Front View.

External Components--Continued

NOTE

90-ton snatch block retainers are welded to hull.

1. Rear tow bar brackets
2. Pioneer tool set bracket and straps
3. Lifting chain clamps
4. Roadwheel
5. Sprocket
6. Support wheel
7. M13 decontamination apparatus

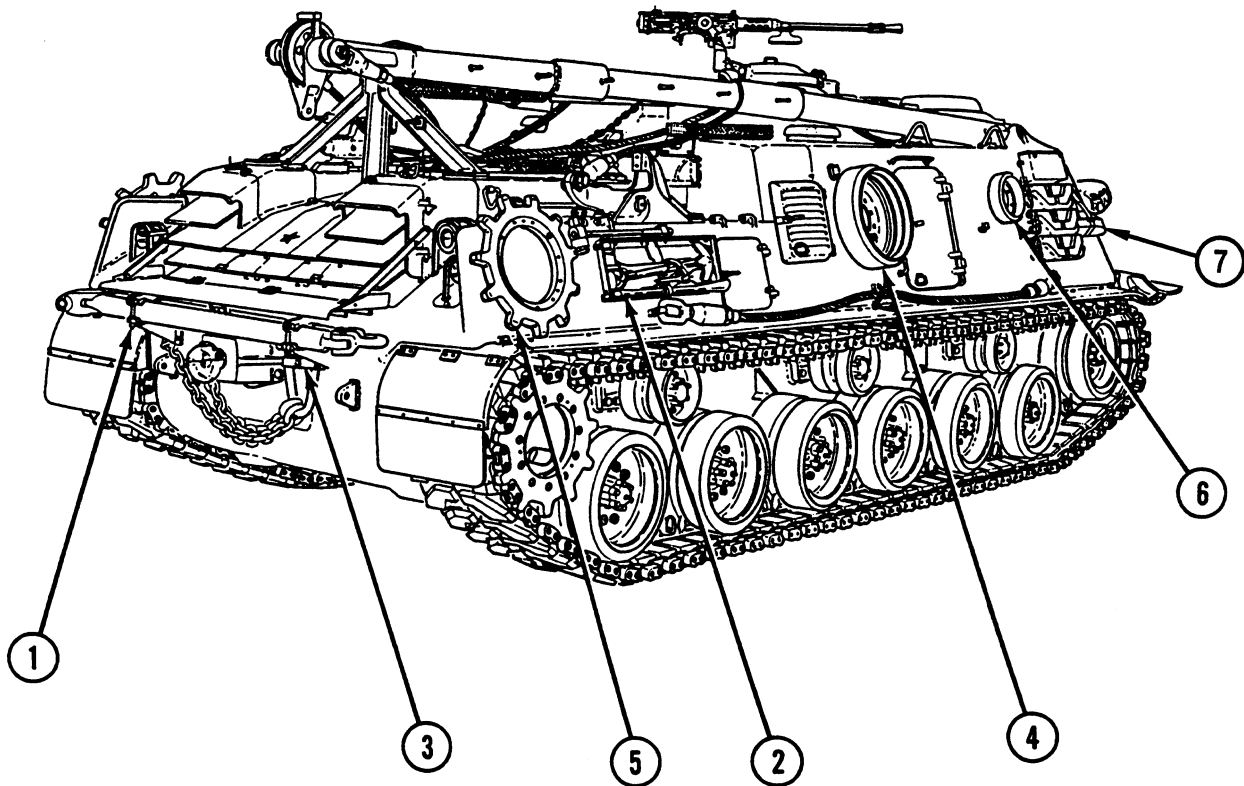

Figure 9. Right Rear View.

Internal Components

General

1. Hydraulic control panel—contains controls for hoisting boom, spade, main winch, hoist winch, hydraulic power, and auxiliary and main hydraulic systems
2. Driver's and mechanic's seats
3. Commander's seat
4. Rigger's seat
5. Personnel heater—electrically controlled, multifuel, combustion heater for heating cab interior
6. APU—provides power to charge batteries and operate hydraulic system when main hydraulic system pump does not operate
7. Engine—provides power to vehicle
8. Cross-drive transmission—transmits power directly from engine to track drive components
9. Fuel tank installation—consists of three fuel tanks, one under crew subfloor and one on each side of engine, which supply fuel to engine, APU, and refuel system
10. Mechanical transmission and hydraulic pump assembly—transmission is driven by engine through a power takeoff (PTO) coupling; transmission drives main hydraulic system pump
11. Hoist winch—capable of holding a maximum load of 50,000 pounds (lb) (22,680 kilograms [kg]) with a 4-part line; used with hoisting boom
12. Fixed fire extinguisher system—used for smothering fires in engine and winch compartments
13. Main winch—used for heavy-duty recovery operations; wound with 200 feet (ft) (61.0 meters [m]) of 1-1/4 inch (in.) (31.8 millimeter [mm]) steel cable

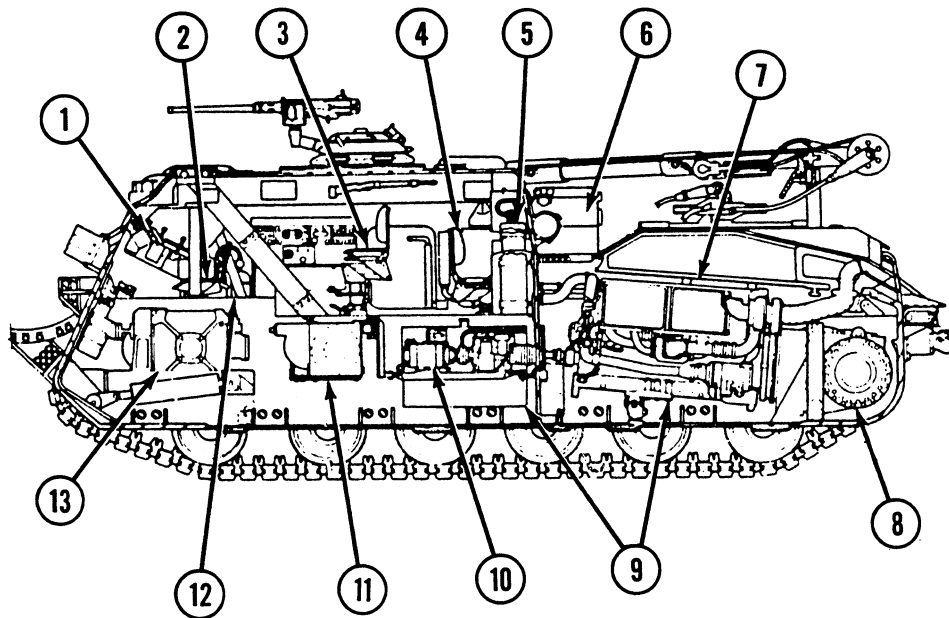

Figure 10. Internal Components.

Internal Components—Continued**Cab Subfloor Plates—Schematic Diagram**

The following illustration is a locator view for subfloor plates associated with WP 0286 00 thru 0308 00.

1. Right-front access floor plate (see WP 0286 00)
2. Right-front floor plate rear access (see WP 0287 00)
3. Hydraulic valve forward right floor plate (see WP 0288 00)
4. U-35 winch center right floor plate (see WP 0289 00)
5. Intermediate rear right floor plate (see WP 0290 00)
6. Rear right-side floor plate (see WP 0291 00)
7. Hydraulic connections access cover (see WP 0292 00)
8. Rear intermediate right floor plate (see WP 0293 00)
9. Rear intermediate right access cover (see WP 0294 00)
10. Rear intermediate right access floor plate (see WP 0295 00)
11. Hydraulic line intermediate rear right center floor plate (see WP 0296 00)
12. Rear center floor plate (see WP 0297 00)
13. Rear left-side intermediate floor plate (see WP 0298 00)
14. Fuel transmitter center left floor access plate (see WP 0299 00)
15. Rear left-side floor plate (see WP 0300 00)
16. Intermediate rear left-side floor plate (see WP 0301 00)
17. Intermediate rear left-center floor plate (see WP 0302 00)
18. Center rear floor plate (see WP 0303 00)
19. Center forward floor plate (see WP 0304 00)
20. Intermediate rear left access floor plate (see WP 0305 00)
21. Stowage basket forward intermediate left floor plate (see WP 0306 00)
22. Floor and light mount plate (see WP 0307 00)
23. Hydraulic valve forward intermediate right floor plate (see WP 0308 00)

Internal Components—Continued

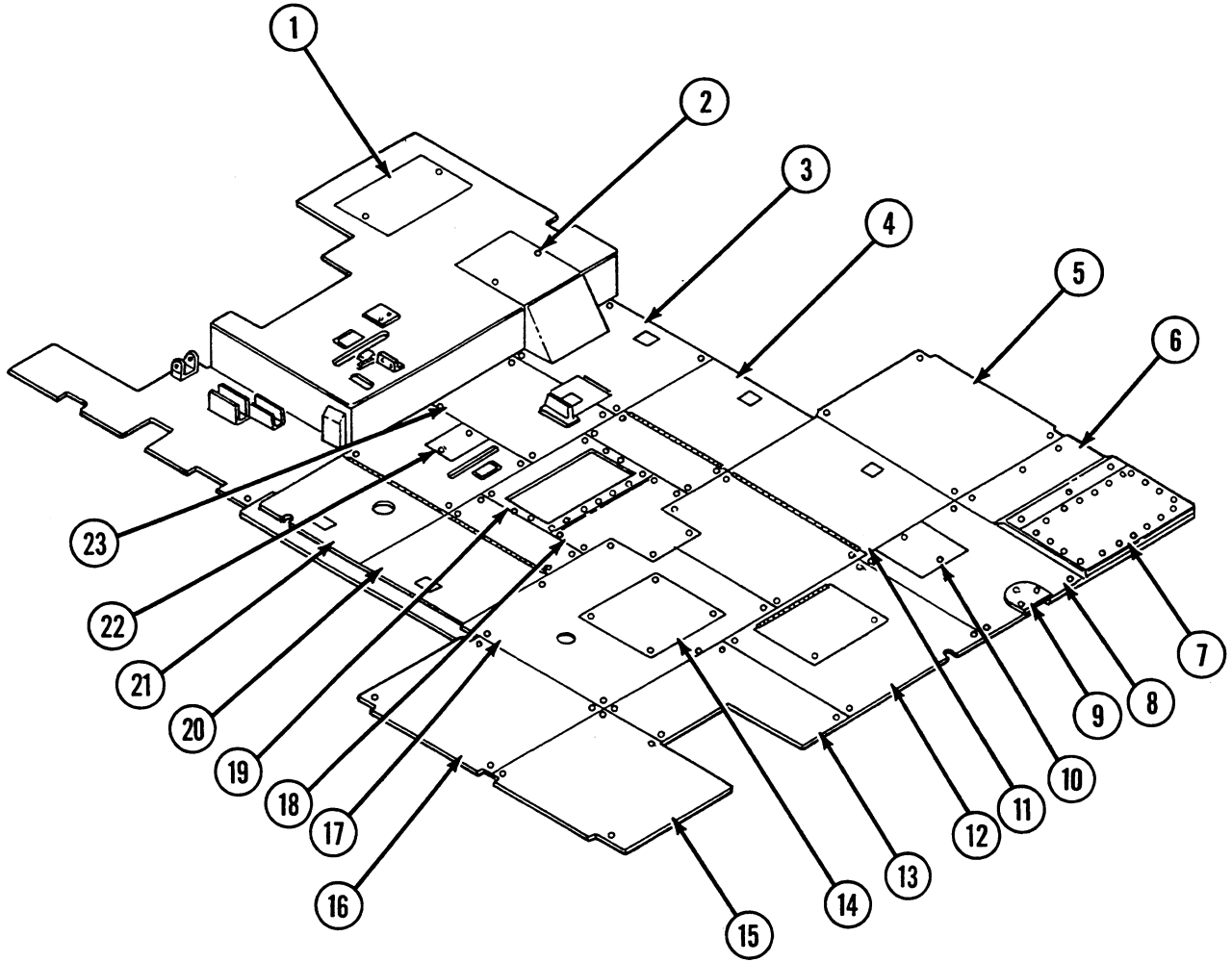

Figure 11. Subfloor Plates.

Internal Components—Continued

Fixed Fire Extinguisher System—Schematic Diagram

The following two illustrations provide an overview of the fixed fire extinguisher system lines and nozzles associated with WP 0400 00 thru 0403 00.

1. Outside remote control box
2. Conduit assembly, control box to dual-pull mechanism
3. Dual-pull mechanism mounting bracket, left- and right-side
4. Dual-pull mechanism
5. Cable pulley assembly
6. Dual-pull mechanism to cylinder assembly
7. Control valve
8. Engine shutoff
9. Pull handle, right-side
10. Pull handle, left-side
11. Rubber pressure hose

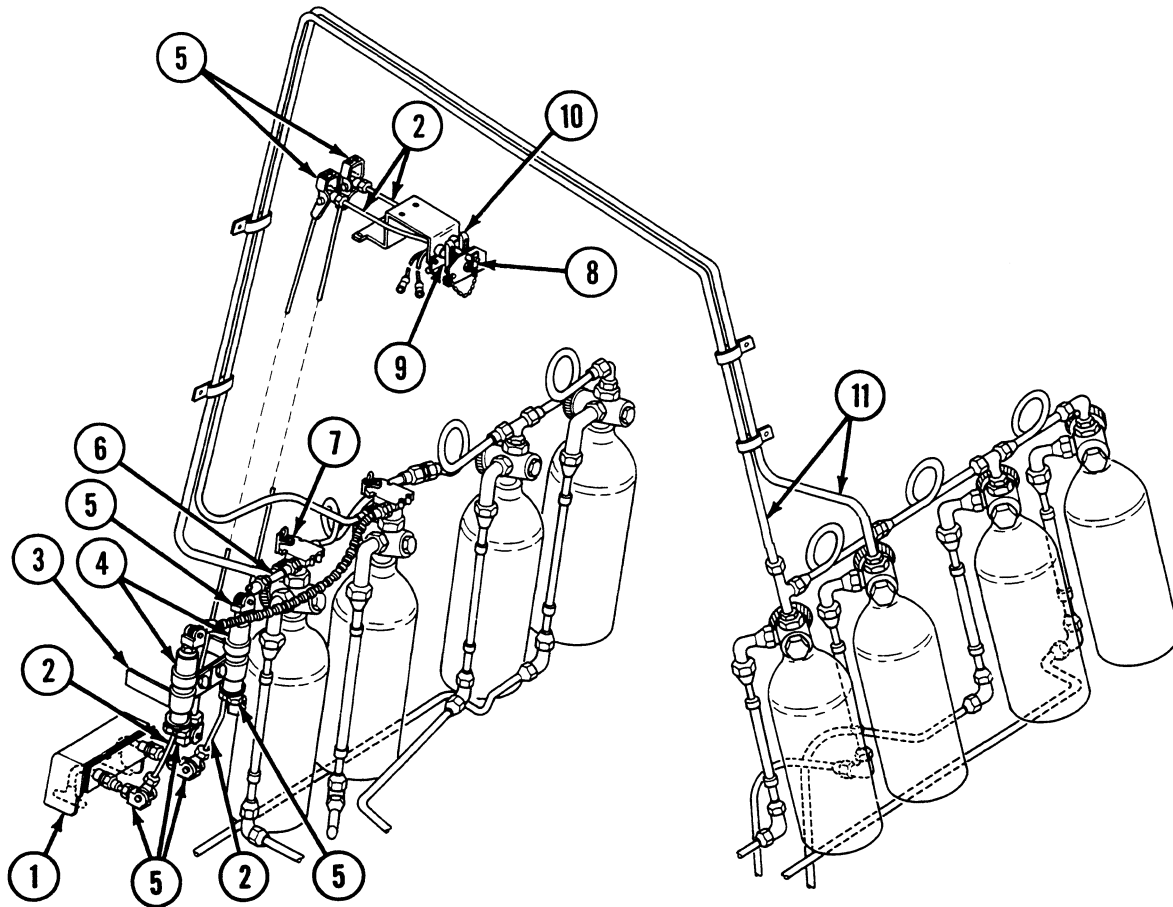

Figure 12. Fixed Fire Extinguisher System (1 of 2).

Internal Components—Continued

1. Rear left- and right-side cylinder No. 1 to rear of engine tube assembly
2. Rear left-side cylinder No. 1 to rear of engine tube
3. Intermediate left-side cylinder No. 1 to rear of engine tube assembly
4. Intermediate left-side cylinder No. 1 to rear of engine tube assembly
5. Pressure connecting head hose assembly
6. Carbon dioxide cylinder control valve
7. Left and right intercylinder and valve control tube assembly
8. Left and right intercylinder connecting tube assembly
9. Left and right intercylinder connecting tube assembly
10. Front left-side cylinder No. 1 to rear of engine tube assembly
11. Front left-side cylinder No. 2 to front of engine and engine bottom tube assembly
12. Winch compartment front of firewall to tube hose assembly
13. Front lower left-side cylinder No. 3 to front and top of engine bank tube assembly
14. Front lower right-side cylinder No. 3 to front and top of engine bank tube assembly
15. Right-side cylinder No. 4 to winch compartment front of firewall tube assembly
16. Front right-side cylinder No. 3 to front and top of engine bank tube assembly
17. Front right-side cylinder No. 1 to rear of engine tube assembly
18. Front right-side cylinder No. 2 to front of engine and engine bottom tube assembly
19. Intermediate right-side of cylinder No. 1 to rear of engine tube
20. Intermediate right-side of cylinder No. 1 to rear of engine tube
21. Rear right-side cylinder No. 1 to rear of engine tube
22. Nozzle
23. Rear of engine bottom tube assembly
24. Rear of engine check valve and bottom tube tee vertical connector tube assembly
25. Right-side cylinder No. 3 to left front and top of engine bank tube assembly
26. Right-side cylinder No. 3 to left front and top of engine bank tube assembly
27. Front left-side cylinder No. 3 to front and top of engine bank tube assembly
28. Left-side cylinder No. 4 to winch compartment front of firewall tube assembly
29. Left- and right-side cylinder No. 4 to winch compartment front of firewall tube assembly
30. Center lower left-side cylinder No. 3 to front and top of engine bank tube assembly
31. Right-side cylinder No. 4 to winch compartment front of firewall rear nozzle tube assembly
32. Center lower right-side cylinder No. 3 to front and top of engine bank tube assembly
33. Right-side cylinder No. 3 to front and top of engine bank tube assembly
34. Right-side cylinder No. 3 to front and top of engine bank tube assembly
35. Right-side cylinder No. 3 to front and top of engine bank tube assembly
36. Firewall from left-side cylinder No. 3 to left front bottom of engine tube assembly

Internal Components—Continued

- 37. Firewall from left-side cylinder No. 3 to engine vee extinguisher hose tube assembly
- 38. Left-side cylinder No. 2 to engine vee extinguisher hose assembly
- 39. Left-side cylinder No. 2 to engine vee extinguisher valve

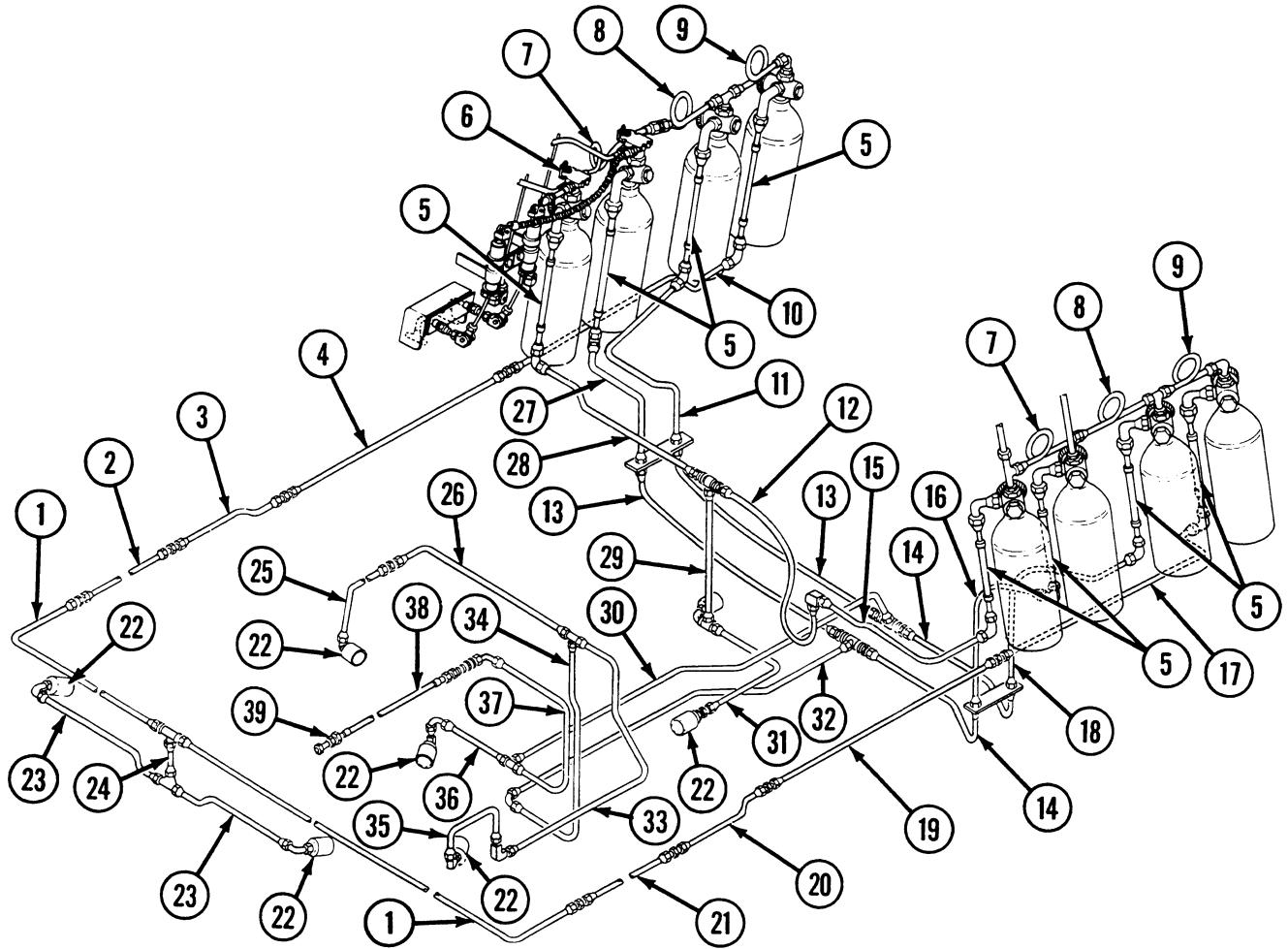

Figure 12. Fixed Fire Extinguisher System (2 of 2).

Internal Components—Continued

M8A3 Gas/Particulate Filter Units—Schematic Diagram

The following illustration is a locator view of the of various M8A3 filter assemblies associated with WP 0439 00 thru 0441 00.

1. Driver's hose assembly
2. Mechanic's hose assembly
3. Commander's hose assembly
4. M2A2 air purifier and frame assembly (right side)
5. Rigger's hose assembly
6. M2A2 air purifier and frame assembly (left side)
7. Passenger's (AFT) hose assembly
8. Passenger's (FWD) hose assembly

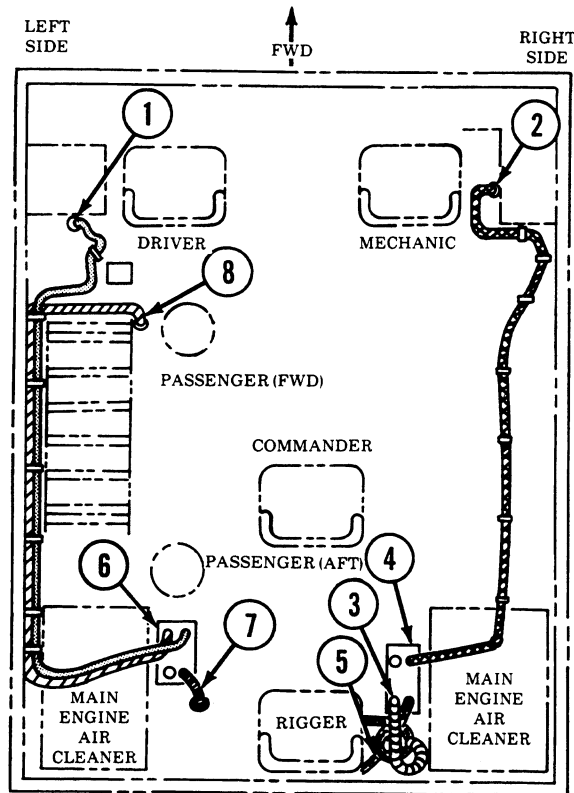

Figure 13. M8A3 Filter Assemblies.

Internal Components—Continued**Stowage—Schematic Diagram**

The following two illustrations are of the right and left interior stowage areas associated with WP 0382 00 thru 0394 00.

1. Hose rack and retainers
2. Flasher light case and brackets
3. Caliber .50 barrel straps
4. M16 strap
5. Hand grenade boxes
6. Rocket ammunition stowage box assembly
7. Stowage straps
8. Hand fire extinguisher bracket (right side)
9. Liquid container stowage basket
10. Stowage baskets (under floor)

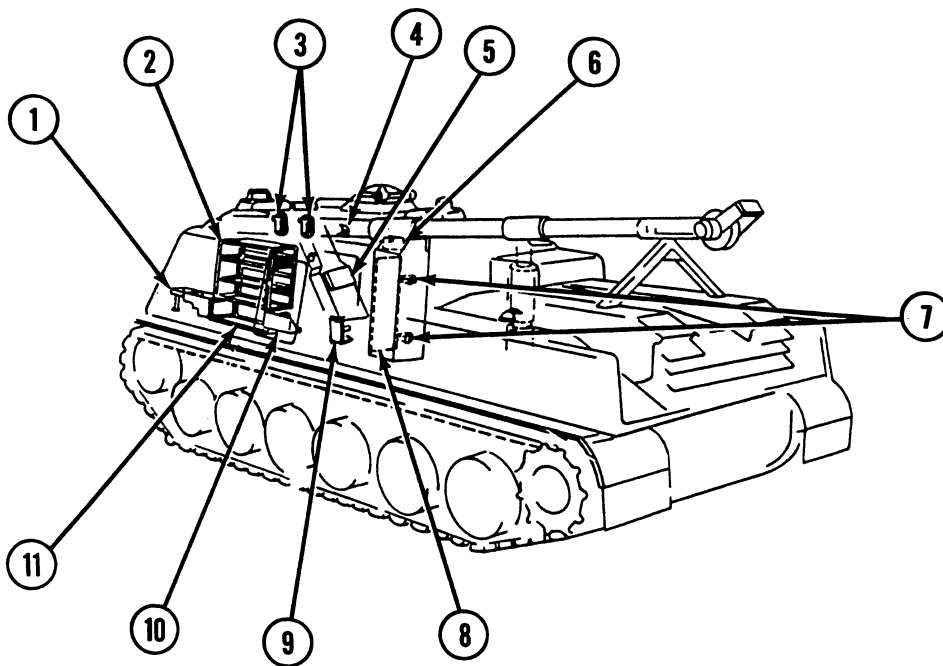

Figure 14. Left Rear View.

Internal Components—Continued

1. Oddment tray and signal flare rack
2. Caliber .50 ammunition rack
3. M72 LAW bracket assembly
4. Caliber .45 machine gun
5. Passive night viewer stowage box, AN/VVS-2
6. Oddment compartment door retainer
7. Acetylene cylinder brackets
8. Acetylene compartment door hardware and sealing strip
9. Hand fire extinguisher bracket (left side)
10. Liquid container mounting brackets

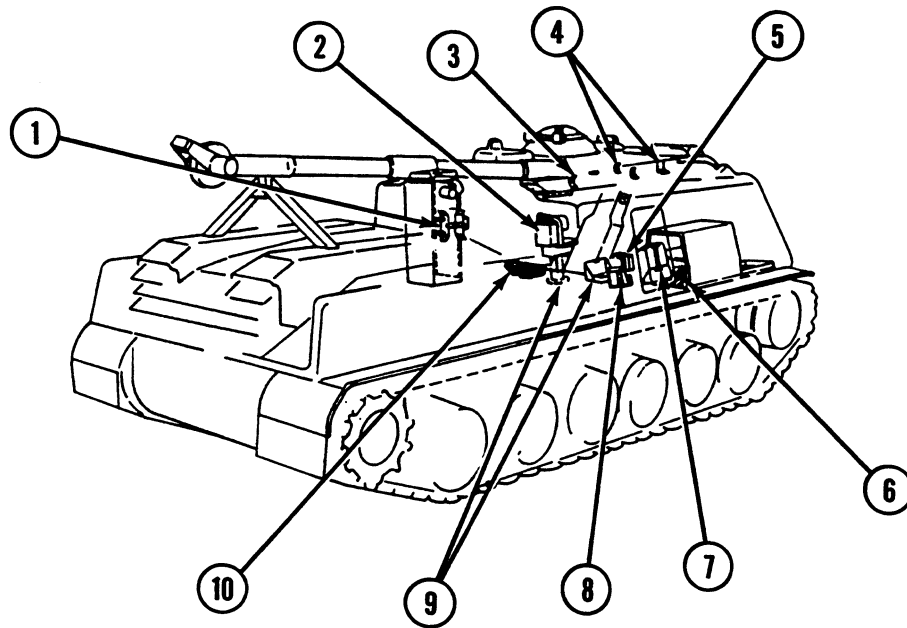

Figure 15. Right Rear View.

Identification (ID) Plates

The following illustration is of the ID plates associated with WP 0395 00.

RECOVERY VEHICLE FULL TRACKED MED M88A1 CREW 4 MEN		
ORDNANCE CORPS U.S. ARMY SERIAL NO. []		
MFD BY []	[]	
OPERATORS MANUAL-TM [9-2350-256-10]	[]	
MAINTENANCE MANUALS-TM [9-2350-256-20]	[]	
[9-2350-256-20P] [9-2350-256-34/1] [9-2350-256-34/2] [9-2350-256-34P]	[]	
[9-2350-256-34P/2] [9-2815-221-34] []	[]	
MAX VEHICLE SPEEDS		
LOW [5] MPH	INTER [12] MPH	HIGH [26] MPH
OVERALL LENGTH [325.3]	LOWEST OPERABLE HGT [115]	[]
OVERALL WIDTH [135]	SHIPPING CUBIC [2947]	[]
OVERALL HEIGHT [73]	FIGHTING WEIGHT [12,000]	[]
ORDNANCE STOCK NO. [2350-00-122-6826]	[]	[]

AIR PURIFIER, M2A2	
COMPONENT OF FILTER UNIT	
GAS PARTICULATE, TANK,	
12 CFM, M8A3, ABC	
PART NO. D5-19-1772	24V AC-DC MOT
STK NO. 4240-853-3201	
LOT NO. []	[]
SER NO. []	[]
INDUSTRIAL DESIGN LABORATORIES, INC.	
CONTR NO. DAAA15-67-C-0309	[]
INSPECTED []	US

VEHICLE NAME PLATE

AIR PURIFIER NAME PLATE

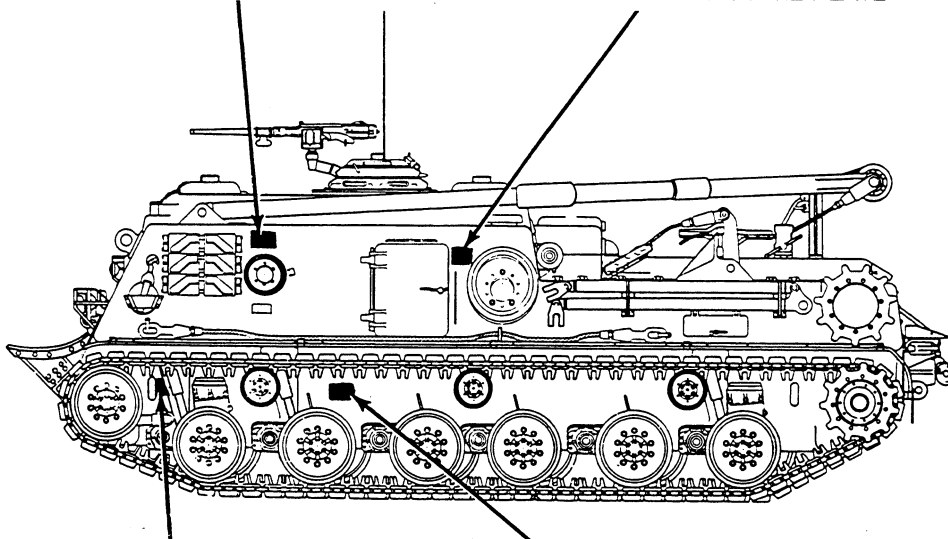

CARCO WINCH	
MODEL U-90-B	SERIAL NO. []
U.S. ARMY NO. 8739010	[]
MANUFACTURED BY	
PACIFIC CAR & FOUNDRY CO.	
RENTON, WASHINGTON U.S.A.	

MAIN WINCH NAME PLATE

CARCO WINCH	
MODEL U-35-B	SERIAL NO. []
U.S. ARMY NO. 8739009	[]
MANUFACTURED BY	
PACIFIC CAR & FOUNDRY CO.	
RENTON, WASHINGTON U.S.A.	

HOIST WINCH NAME PLATE

Figure 16. ID Plates (1 of 2).

Identification (ID) Plates—Continued

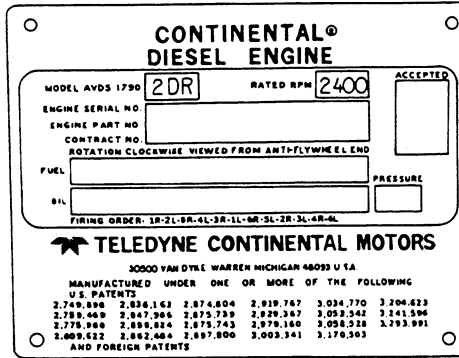

ENGINE NAME PLATE

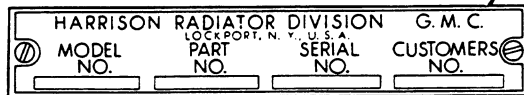
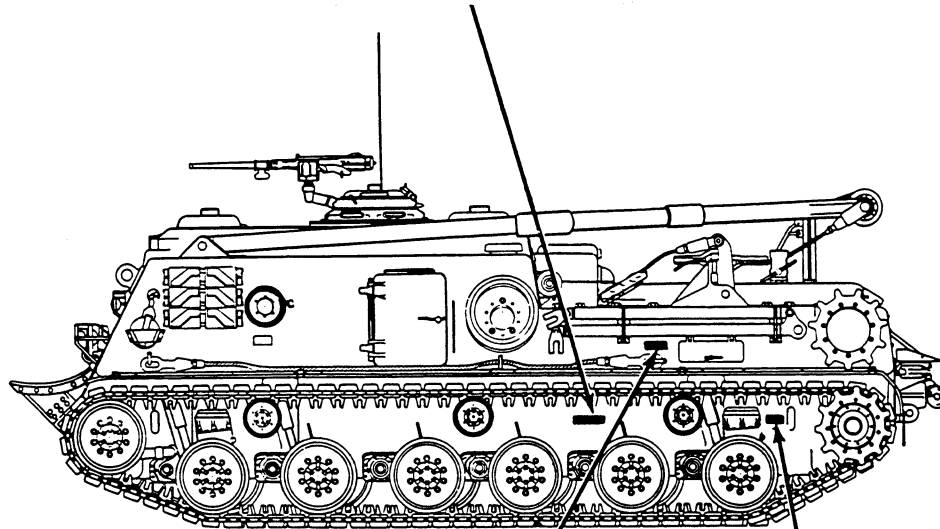

OIL COOLER NAME PLATE

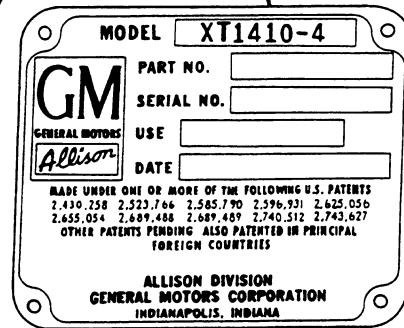

TRANSMISSION NAME PLATE

Figure 16. ID Plates (2 of 2).

Painting and Restenciling Markings

Stenciled markings must be renewed periodically because of weathering or repainting. To restencil markings, paint lusterless black on forest green background. U.S. Army and vehicular registration markings are approximately 3 in. (76 mm) high in block, Gothic, capital letters. Locational marking letters (such as: Tow Bar, Tie Down, etc.) are 1/2 in. (13 mm) high (within 1.16 in. [29.5 mm]), 3/32 in. (2.4 mm) wide (within 1/32 in. [0.8 mm]), and spaced 1/4 in. (6.4 mm) between lines. Refer to the locator views (Figure 17) for required stenciled markings and location of lettering positions.

Instructions for the preparation of the materiel for painting, methods of painting, and materials to be used are contained in TM 43-0139. See WP 0348 00 for instructions on painting fender walkways.

Painting and Restenciling Markings—Continued
Stenciled Markings

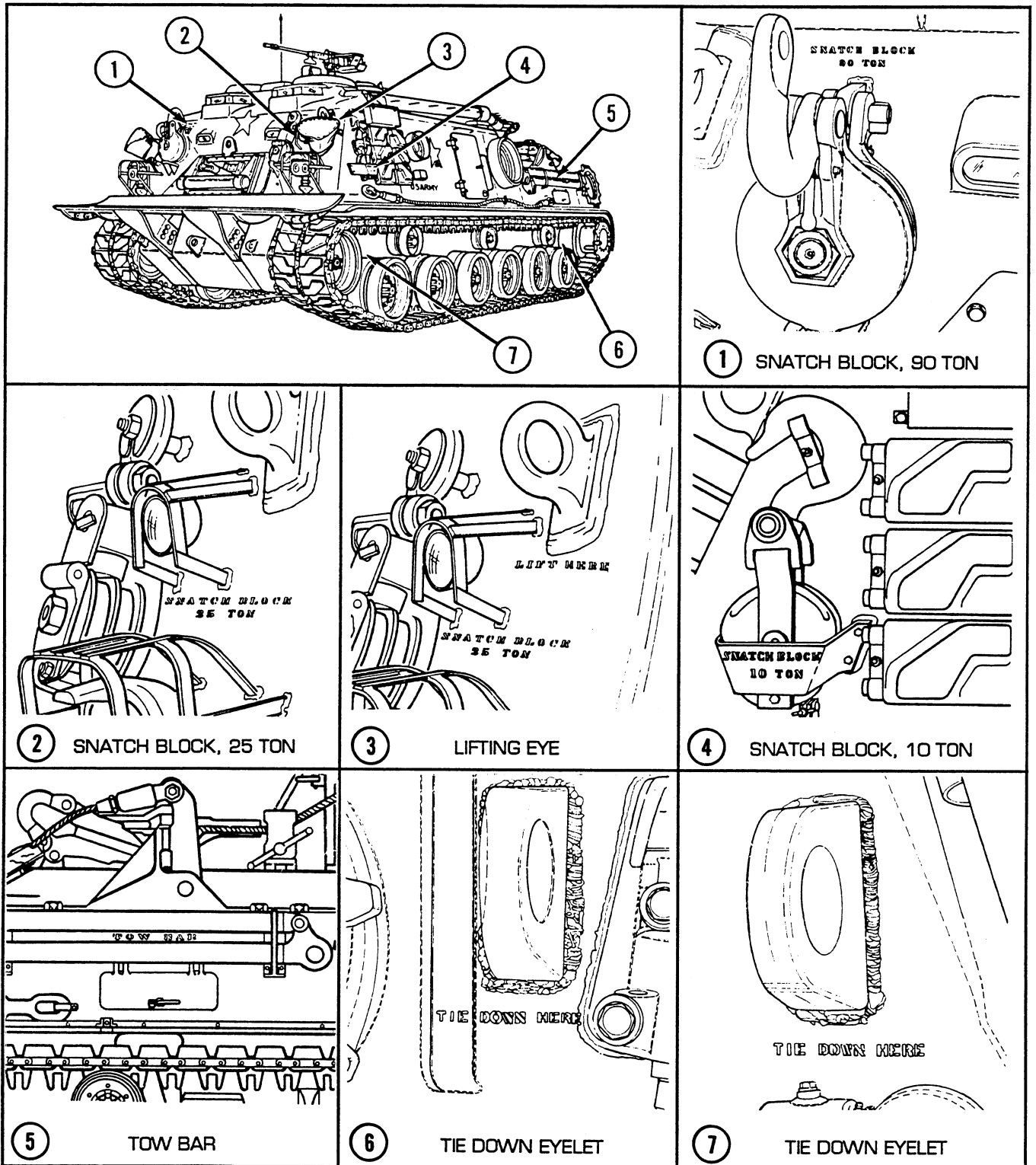

Figure 17. Stenciled Markings (1 of 4).

Painting and Restenciling Markings—Continued

Stenciled Markings—Continued

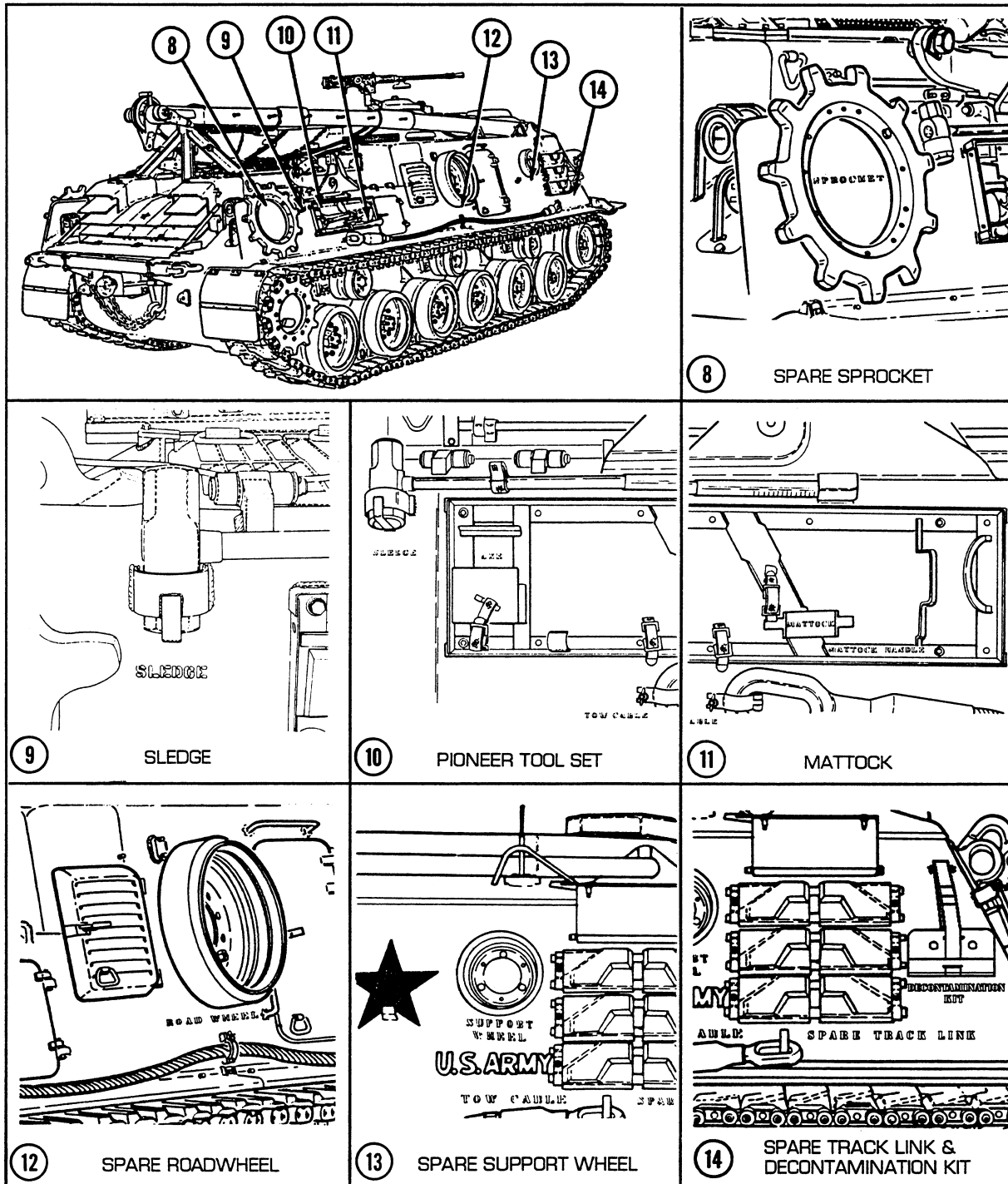

Figure 17. Stenciled Markings (2 of 4).

Painting and Restenciling Markings—Continued

Stenciled Markings—Continued

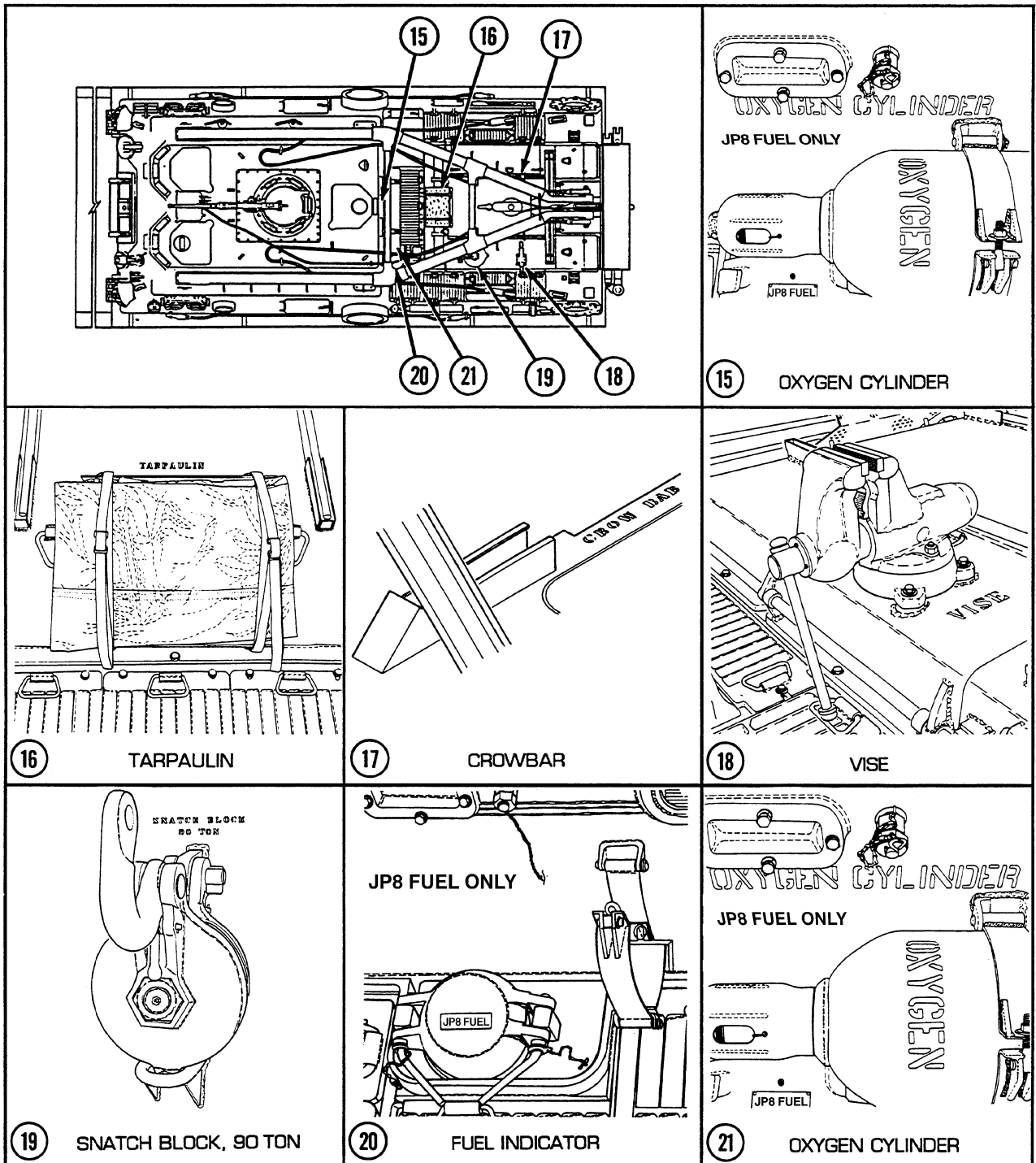

Figure 17. Stenciled Markings (3 of 4).

Painting and Restenciling Markings—Continued

Stenciled Markings—Continued

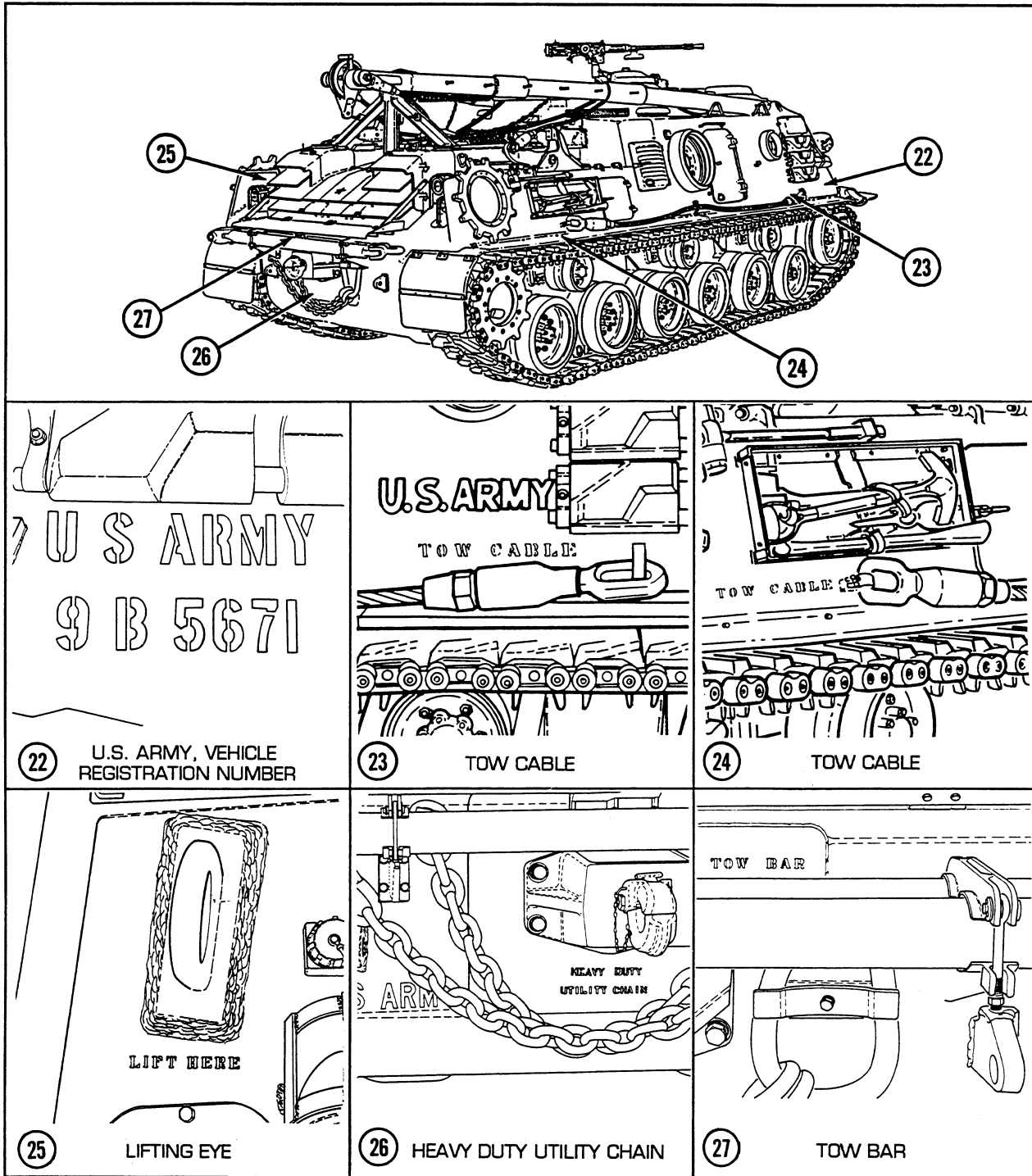

Figure 17. Stenciled Markings (4 of 4).

DIFFERENCES BETWEEN MODELS

There are several optional configurations for the M88A1. The major differences between models are as follows:

Engine Deck

Earlier versions of the M88A1 have the original engine deck with integral hinges that connect the engine deck and the right-side door. Later models have the new, optional engine deck with hinges that are connected by screws to the deck and then welded.

Voltage Regulator

Earlier versions of the M88A1 have a single voltage regulator. Later versions of the vehicle have dual voltage regulators. See foldouts 3, 5, 7, and 9 for configuration differences.

Spade Release

Earlier versions of the M88 have a mechanically operated spade which is released through the use of cables and linkages. Later versions have a hydraulically operated spade.

Passive Night Viewer Device

Earlier versions use an infrared (IR) light device that allows for night viewing, while current vehicles use the passive night viewer device.

EQUIPMENT DATA

TRACKS AND SUSPENSION

Table 1. Tracks and Suspension

Shoes in each track section	84
Track support rollers (pairs)	3
Roadwheel and arm assemblies (pairs)	6
Suspension	Torsion-bar type

Table 2. Fuel Capacities

All tanks (total)	400 gallons (gal) (1514 liters [L])
Forward tank	252 gal (954 L)
Left rear tank	74 gal (280 L)
Right rear tank	74 gal (280 L)

Table 3. Performance

Fuel consumption	0.7 mile per gallon (0.30 kilometer per liter)
Engine oil consumption (maximum [max] allowable)	0.2 gal in 1 hour (hr) (0.8 L in 1 hr)

Table 4. Engine

Make and type	Continental, 12-cylinder, air-cooled, 90-degree, V-type, compression-ignition
Model	AVDS-1790-2DR
Dimensions:	
Length (transmission adapter to fuel pump drive housing)	72.50 in. (1841.5 mm)
Width (including turbosuperchargers)	70.25 in. (1784.4 mm)
Height	45.30 in. (1150.6 mm)
Displacement	1790 cubic inches (29,333 cubic centimeters)
Weight, dry (with accessories)	5050 lb (2290.7 kg)
Speed, governed:	
Full load	2400 to 2450 revolutions per minute (rpm) max, at rated load
No load	2640 rpm max
Idle	675 to 725 rpm
Winching	1800 ± 25 rpm
Horsepower (hp):	
Gross	750 brake horsepower (bhp) at 2400 rpm
Net	642 bhp at 2400 rpm
Cooling system	Engine-driven fans for cylinders, transmission, and engine coolers
Induction system	Supercharged by two exhaust-driven turbosuperchargers
Oil temperature:	
Normal	140 to 240°F (60 to 116°C)
Max (out of cooler)	250°F (121°C)
Fuel:	
Type	Diesel
Grade	JP8
Specification	VV-F-800
Rating	40 cetane minimum (min)
Consumption	29.8 gallons per hour (113 liters per hour) at 2400 rpm and 750 hp
Torque:	
Gross	1720 pound-feet (lb-ft) (2332 newton-meters [N•m]) at 1800 rpm
Net	1585 lb-ft (2148.9 N•m) at 1800 rpm
Firing order	1R, 2L, 5R, 4L, 3R, 1L, 6R, 5L, 2R, 3L, 4R, 6L
Bore	5.750 in. (146.05 mm)

Table 4. Engine—Continued

Stroke	5.750 in. (146.05 mm)
Compression ratio	16:1
Crankshaft rotation	Clockwise as viewed from front
Injector pump ratio	1:1
Valves	Overhead-type, two per cylinder, actuated by a single, overhead camshaft per each bank
Drive	Integral flywheel ring gears
Lubricating oil:	
Type	Refer to TM 9-2350-256-10 and see WP 0097 00
Capacity:	
Dry engine	78 quarts (qt) (73.8 L)
Oil change (approximate)	63 qt (59.6 L)
Oil pressure (crankcase main oil gallery):	
At 675 to 725 rpm (idle)	20 pounds per square inch (psi) (138 kilopascals [kPa]) (OE 30) at 180°F (82°C)
At 2400 to 2450 rpm (full load)	40 to 70 psi (276 to 483 kPa) (OE 30) at 180°F (82°C)

Table 5. Engine-Related Components

Generator	Teledyne Continental Motors
Voltage regulator, solid-state (dual)	11672403-1
Voltage regulator, solid-state (single)	11659111-1
Starter	Delco-Remy
Batteries	Type 6TN: 12 volts (V), 100 ampere-hours (A-hr)

Table 6. Transmission and Output Reduction Drives

Type (transmission)	Cross-drive
Model (transmission)	XT-1410-4
Dimensions:	
Length, overall (approximate)	42 in. (1067 mm)
Height	31.75 in. (806.5 mm)
Width (between sides of hull)	74 in. (1880 mm)
Weight, dry (approximate)	6611 lb (2998.7 kg)
Suspension	Three-point (engine and two supports)
Drive ranges	Low, intermediate, high, reverse
Shift and steering control (external)	Mechanical
Shift and steering control (internal)	Hydraulic

Table 6. Transmission and Output Reduction Drives—Continued

Drive ranges control	Multiple-disk clutch
Clutches engaged by	Oil pressure
Clutches released by	Spring pressure
Brakes:	
Type	Multiple-plate, wet
Duty	Servicing and parking
Application and release	Mechanical
Cooled by	Circulating oil
Oil capacity:	
Initial fill	27 gal (102 L)
Refill	17 gal (64 L)
Oil cooled by	External radiators
Oil filter type	Four-element convolute

Personnel Heater

Refer to TM 9-2540-205-24&P for heater description and data.

Table 7. Hoist Winch

Part Number (PN)	8739009
Make	Pacific Car and Foundry Co.
Model	U35B
Cable size	0.625 in. (15.88 mm) diameter (dia)
Cable length	200 ft (61.0 m)

Table 8. Main Winch

PN	873901C
Make	Pacific Car and Foundry Co.
Model	U90B
Cable size	1.25 in. (31.8 mm) dia 6 x 31 IWRC
Cable length	200 ft (61.0 m)

Table 9. Auxiliary Engine

PN	11671652
Make	ONAN
Type	Two-cylinder, four-cycle diesel
Model	DJBMA
Cooling system	Air-cooled by direct drive centrifugal blower
Bore and stroke	3.250 x 2.625 in. (82.55 x 66.68 mm)
Hp (full load)	10.8 at 2000 ± 100 rpm
Auxiliary generator:	
PN	MS51004-1
Auxiliary hydraulic pump:	
PN	11671411
Auxiliary engine fuel filter assembly:	
PN	11671506
Make	ONAN
Auxiliary engine oil filter:	
PN	122-0185
Make	ONAN
Type	Replaceable
Auxiliary engine fuel transfer pump:	
PN	149-0429
Make	ONAN

Table 10. Deep Water Fording Kit

Bilge pump:	
PN	10894565
Make	Piqua Machine and Manufacturing Co.
Model	S-100
Hp	1
V direct current (dc)	27.5
Amperes (A)	47
Solenoid relay:	
Type	Single-pole, single-throw, normally open, 28 V dc, 50 A
Coil:	
PN	8762321
Continuous voltage	29 V dc max
Voltage pickup and seal	13 V dc max, 13 V dc min
Voltage dropout	7 V dc max, 1.5 V dc min
Circuit breaker:	
Type	Thermal, automatic reset, nonwaterproof
Capacity	50 A max

Additional Tabulated Data

Refer to TM 9-2350-256-10.

END OF WORK PACKAGE

UNIT MAINTENANCE
RECOVERY VEHICLE, FULL TRACKED: MEDIUM, M88A1
NSN 2350-00-122-6826, EIC AQA
POWERPLANT THEORY OF OPERATION

Powerplant

General

The powerplant consists of the engine and cross-drive transmission with a right and left output reduction gear drive. The powerplant is removed from the vehicle as one complete unit.

Throughout this manual, the front of the engine is referred to as the damper end or front, and the rear of the engine is referred to as the flywheel end or rear.

As viewed from the front (damper end) toward the rear (flywheel end), the side to the right is called the right side and the side to the left is called the left side. Beginning at the front, the right bank of cylinders is numbered 1R through 6R, and the left bank of cylinders is numbered 1L through 6L (see Figure 1).

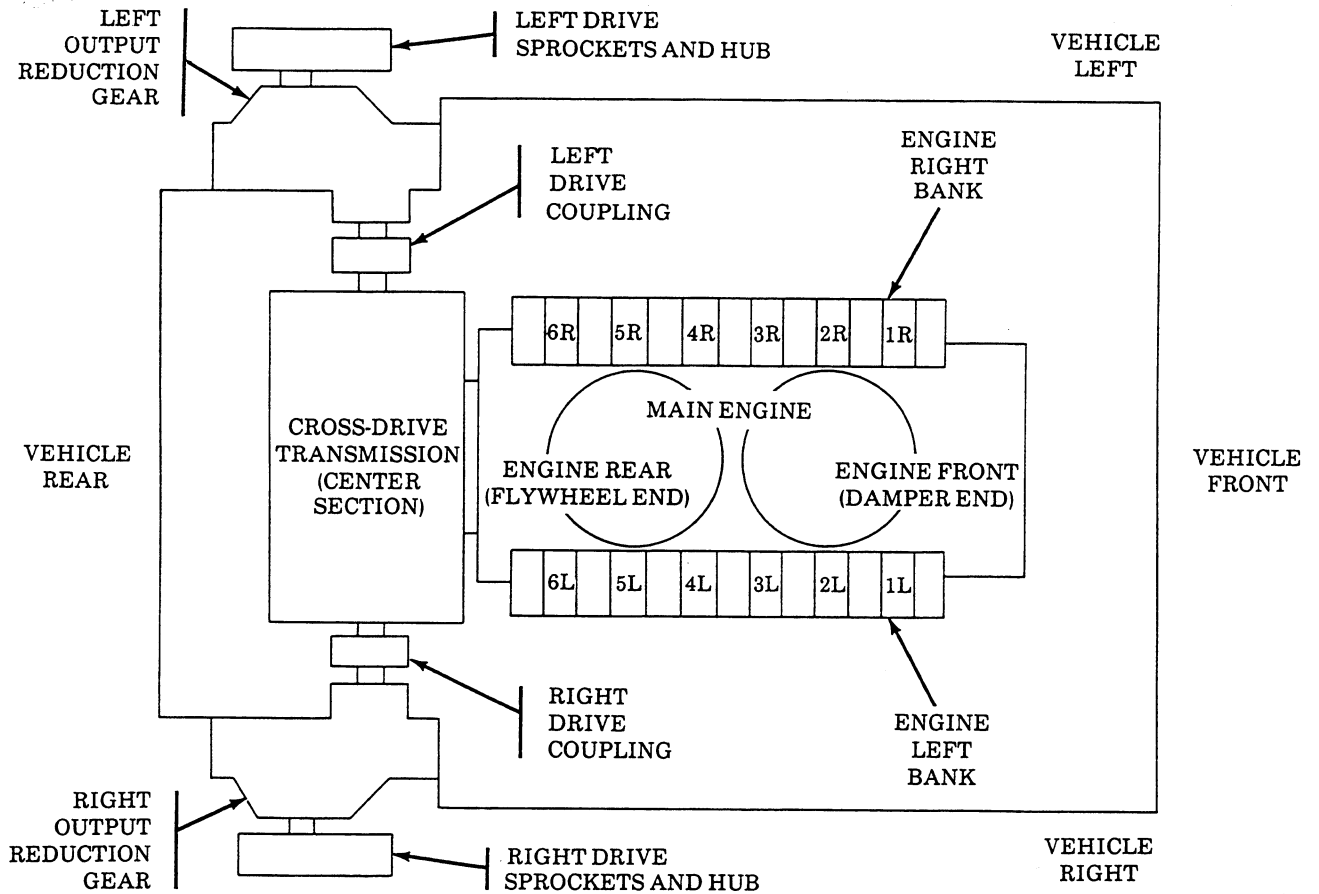

Figure 1. Powerplant Diagram.

Engine

The Continental model AVDS-1790-2DR engine is a 12-cylinder, 90-degree, V-type, 4-cycle, air-cooled, turbosupercharged, diesel engine. The cylinder assemblies are individually replaceable units with overhead valves and valve rocker assemblies in the head. The cylinders are arranged in two banks of six cylinders each. Each bank of cylinders has an overhead camshaft arrangement to actuate the valves of each cylinder.

The engine features a fuel injection system and a turbosupercharged, air induction system. The fuel injection system utilizes a fuel injection metering pump which supplies metered fuel to individual cylinders through fuel injector nozzles. The fuel pump assembly (22), located at the front of the engine, delivers fuel to the injector pump. A turbosupercharger (7 and 29) is located on each side of the engine at the rear. The turbosuperchargers are exhaust-gas driven and increase the airflow pressure entering the air intake manifolds. The engine is equipped with a 28-V, 300-A, dc generator (9) and a 24-V, solenoid-operated starter (34).

The engine is lubricated by a forced-feed system. The system consists of three circuits: the scavenge circuit, the main or pressure oil circuit, and the piston cooling circuit. These circuits are operated independently by one oil pump, which consists of four separate pump sections.

The engine is equipped with two intake manifold heaters (15 and 33) which are installed in the air intake system between the intake manifold elbows and the turbosuperchargers (7 and 29). The heaters, when operated, preheat the air entering the cylinders to facilitate cold-weather starting and cold-weather idle operation.

The engine crankcase is vented by the crankcase breather system which exhausts through the crankcase breather tube at the left turbosupercharger exhaust outlet.

The engine primary fuel filter (2) and fuel/water separator-type secondary fuel filter (26) both have top-mounted bleeder valves to assist in the removal of air from the fuel system. Water is removed automatically by a constant-bleed orifice in the primary fuel filter and an automatic water drain in the fuel/water separator fuel filter.

- | | | | | | |
|---|-------------------------|---|---|---|------------------------------|
| 1 | Oil filter bypass valve | 3 | Engine oil cooler thermostatic bypass valve | 5 | Oil pressure warning switch |
| 2 | Primary fuel filter | 4 | Oil pressure gage transmitter | 6 | Oil pressure regulator valve |

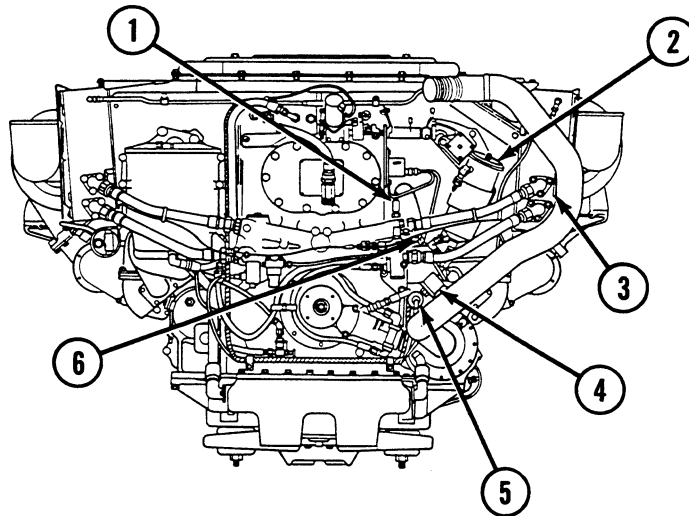

Figure 2. Engine (1 of 4).

- | | | | | | |
|---|-------------------------|----|--|----|--|
| 7 | Right turbosupercharger | 10 | Manifold heater ignition unit | 13 | Transmission oil cooler (right- and left-side) |
| 8 | Transmission | 11 | Primary fuel filter | 14 | Generator boot |
| 9 | Engine generator | 12 | Engine oil cooler (right- and left-side) | 15 | Intake manifold heater |
| | | | | 16 | Cylinder head drain tube |

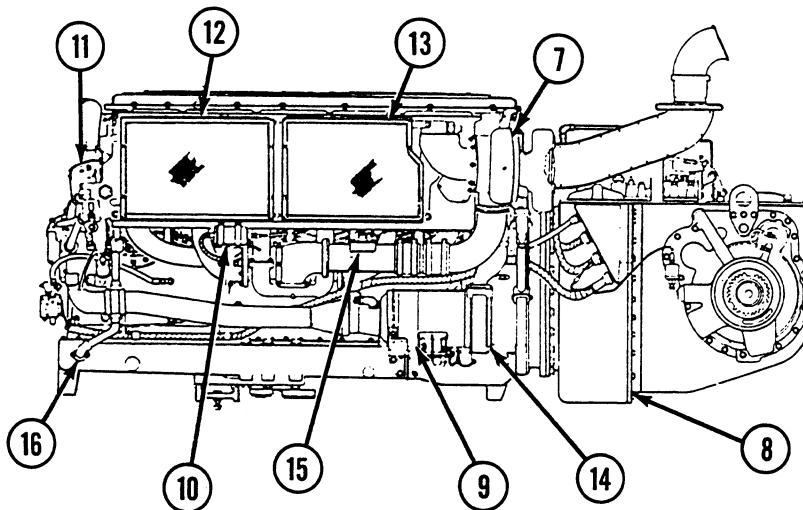

Figure 2. Engine (2 of 4).

- | | | | | | |
|----|-------------------------|----|--------------------------|----|-------------------------------------|
| 17 | Oil cooler bypass valve | 20 | Tachometer drive adapter | 23 | PTO coupling |
| 18 | Oil filter | 21 | Fuel check valve | 24 | Manifold heater fuel filter |
| 19 | Fire extinguisher tube | 22 | Fuel pump assembly | 25 | Manifold heater fuel solenoid valve |
| | | | | 26 | Fuel/water separator fuel filter |

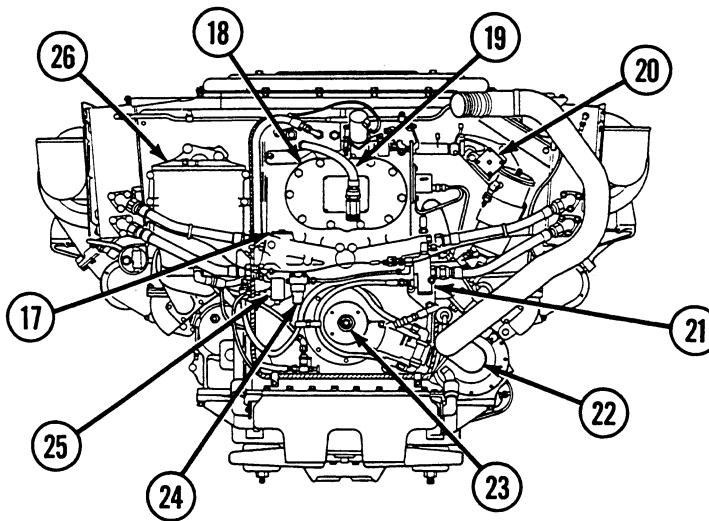

Figure 2. Engine (3 of 4).

- | | | |
|-------------------------------|---------------------------------------|---------------------------|
| 27 Oil level indicator tube | 30 Manifold heater ignition unit | 33 Intake manifold heater |
| 28 Starter low-voltage module | 31 Fuel/water automatic drain control | 34 Engine starter |
| 29 Left turbosupercharger | 32 Air intake manifold | 35 Oil filler tube |

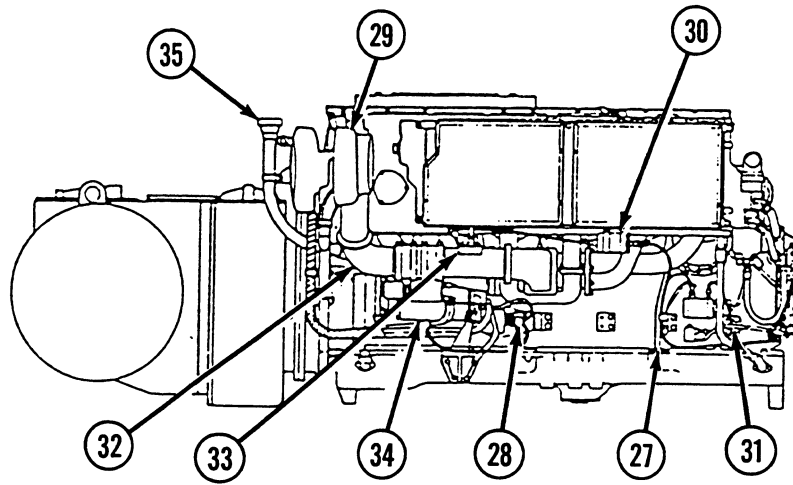

Figure 2. Engine (4 of 4).

END OF WORK PACKAGE

UNIT MAINTENANCE
RECOVERY VEHICLE, FULL TRACKED: MEDIUM, M88A1
NSN 2350-00-122-6826, EIC AQA

LUBRICATION SYSTEM THEORY OF OPERATION

Lubrication System

General

The main pressure oil pump draws oil from the pressure oil pump compartment in the oil pan. This compartment is fed by the scavenge oil pump which picks up oil from the front end of the oil pan and by oil which drains into the pressure compartment from the cover of the pressure pump compartment and the reserve compartment. The pressurized oil is forced through the engine oil coolers and oil filter to the engine oil galleries, bearings, turbosuperchargers, fuel injection pump, and piston oil sprayer nozzles. These nozzles are located in the crankcase below each cylinder and provide a continuous oil spray to the pistons and cylinder walls. A pressure regulator valve, located on the right side of the crankshaft damper and oil filter housing, is influenced by the pressure in the main bearing oil gallery and returns the incoming, excess, unfiltered oil to the oil pan.

Oil Pan

The oil pan is a one-piece, aluminum-alloy casting divided into a pressure oil pump compartment, oil reserve compartment, and sump compartment (at the front of the pan). Cored passages from each of the compartments terminate at a central outlet and permit draining of all of the compartments from a single drainage point. A cored passage also permits draining the oil coolers and oil filter compartment directly without permitting any sludge to enter the oil pan. The oil pan is designed to maintain a constant oil level above the main pressure oil pump pickup tube in the pressure oil pump compartment during vehicle operation, regardless of the angle at which the engine may be inclined.

Oil Pump

The oil pump assembly consists of four sections combined as a single unit. The twin scavenge oil pump section of the unit picks up oil from the front end compartment of the oil pan and delivers it to the main pressure oil pump compartment. The main pressure oil pump section picks up oil from its respective compartment and supplies oil to the engine oil galleries and bearings, and to the piston oil sprayer nozzles. The level in the pressure pump compartment is maintained by a dual-inlet leveling pump which returns any excess oil to the reserve compartment. Oil is pumped from the reserve compartment by two makeup pumps in a single section. These pumps pick up oil from opposite corners of the reserve compartment and discharge it into the pressure pump compartment. The dual pump design ensures return of oil from the reserve compartment under all operating conditions (cold oil, slope operation, etc.).

Oil Filters and Control Valves

The engine oil filters and the bypass valve are located in the crankshaft damper and oil filter housing at the front of the engine. All engine oil passes through the oil filters. The oil filter bypass valve opens at the differential pressure of 35.6 psi (245 kPa). The bypass valve permits oil to bypass the filters in the event that they become clogged.

Crankcase Breather System

The engine crankcase breather system is completely enclosed, which allows the engine to be submerged without the entrance of water and permits the crankcase to be vented. The breather system is vented through the left turbocharger exhaust outlet into the vehicle exhaust system.

Engine and Transmission Oil Coolers

All transmission and engine oil cooling is accomplished by external oil coolers. The oil coolers are located on the sides of the engine, above the cylinders. Air is drawn through the oil coolers by the cooling fans. A thermostatic bypass valve in each oil cooler controls the temperature of the oil from the cooler by permitting cold oil to bypass the coolers. This valve also permits oil to bypass the cooler in the event the cooler becomes clogged.

END OF WORK PACKAGE

UNIT MAINTENANCE
RECOVERY VEHICLE, FULL TRACKED: MEDIUM, M88A1
NSN 2350-00-122-6826, EIC AQA

FUEL SUPPLY, AIR INTAKE, AND EXHAUST SYSTEMS THEORY OF OPERATION

Fuel Supply, Air Intake, and Exhaust Systems

Fuel Supply System

Three fuel tanks supply fuel to the engine, the APU, and the refuel system. Two tanks are adjacent to the engine, one on either side, and the third tank is forward of the bulkhead in the winch compartment. A system of four manually operated control valves maintains fuel flow through the check valve and directs fuel to the engine and refueling systems. These valves are also used to drain the fuel tanks.

The fuel from the vehicle fuel tanks is supplied at a minimum pressure of 5 psi (34 kPa) to the primary fuel filter (3), which is mounted on the engine right front. Fuel flows through the main fuel check valve (5) to the fuel pump assembly (7) mounted on the front center of the engine. This is an engine-driven, gear-type pump; it boosts fuel pressure to the fuel injector pump. A relief valve is incorporated in the pump as a pressure-limiting safety valve.

Fuel from the fuel pump assembly (7) is filtered through the fuel/water separator fuel filter (9) and passes into the fuel injector pump (23). This pump is located in the engine V between the cooling fans. The fuel injector pump delivers accurately metered quantities of fuel under high pressure to each cylinder. An integral governor, of the mechanical centrifugal type, is used to control fuel delivery as a function of engine speed. Engine shutoff is accomplished by a normally open solenoid control unit in the fuel injector pump. The engine fuel shutoff switch on the master control panel actuates the circuit to close the solenoid. Closing of the solenoid cuts off fuel delivery from the injector pump and stops the engine. The engine is equipped with a manual fuel shutoff control to stop the engine if the electric fuel shutoff should fail. A bleeder pressure-relief valve in the pump outlet maintains a constant fuel pressure by allowing any accumulated air and excess fuel to return to the fuel tanks through the engine and fuel tank fuel return lines, check valve, hose, and selector valve. Excess fuel is used to lubricate and cool the fuel injector pump. The check valve prevents a backflow of fuel into the injector from the fuel return line and prevents continued engine operation after the fuel shutoff valve is closed.

Twelve stainless steel fuel lines (13) carry fuel under high pressure from the fuel injector pump (23) to the 12 fuel injector nozzles (15) on the left and right banks of the engine. The nozzles inject a fine spray of metered fuel under pressure into each cylinder. Excess fuel is carried from the nozzles through fuel return hose assemblies (2) on each cylinder bank to the fuel return system.

A hand-operated purge pump, next to the driver's seat, provides a means of purging the fuel injector pump (23), fuel filters (3 and 9), and engine fuel lines of air. The air is forced by the fuel pressure from the purge pump through the engine fuel lines and back to the fuel tanks through the injector pump fuel return line.

Air Intake System

Two dry-type air cleaners, mounted in the right and left rear of the crew compartment, filter intake air for the engine. A damper control, mounted on each air cleaner, is used to select air intake from either the crew compartment or from outside the vehicle.

Exhaust System

Exhaust pipes connect each exhaust manifold to a turbosupercharger. Exhaust gases are ejected from the engine, via exhaust pipes, through deflector-type louvers at the rear of the vehicle.

- | | |
|--|---|
| 1 Fuel return tube to injection fuel return hose tee (right bank) | 12 Fuel return to fuel tank hose |
| 2 Fuel return hose assembly | 13 Fuel injection pump to injector nozzle tube assembly |
| 3 Primary fuel filter | 14 Fuel injection pump to injector nozzle tube assembly support, clamp plate, and insulator |
| 4 Primary fuel filter outlet to check valve, fuel flow back | 15 Fuel injector nozzle |
| 5 Main fuel check valve | 16 Fuel return tube to injection fuel return hose tee (left bank) |
| 6 Primary fuel filter outlet to fuel pump inlet hose assembly | 17 Fuel return tube cross |
| 7 Fuel pump assembly | 18 Fuel injector line bracket, plate, and insulator |
| 8 Fuel pump outlet to fuel/water separator fuel filter inlet hose assembly | 19 Fuel injection pump inlet hose |
| 9 Fuel/water separator fuel filter | 20 Pressure regulator valve |
| 10 Fuel/water separator manual drain | 21 Fuel return check valve |
| 11 Fuel/water separator outlet hose assembly | 22 Fuel injector pump fuel return hose |
| | 23 Fuel injector pump |

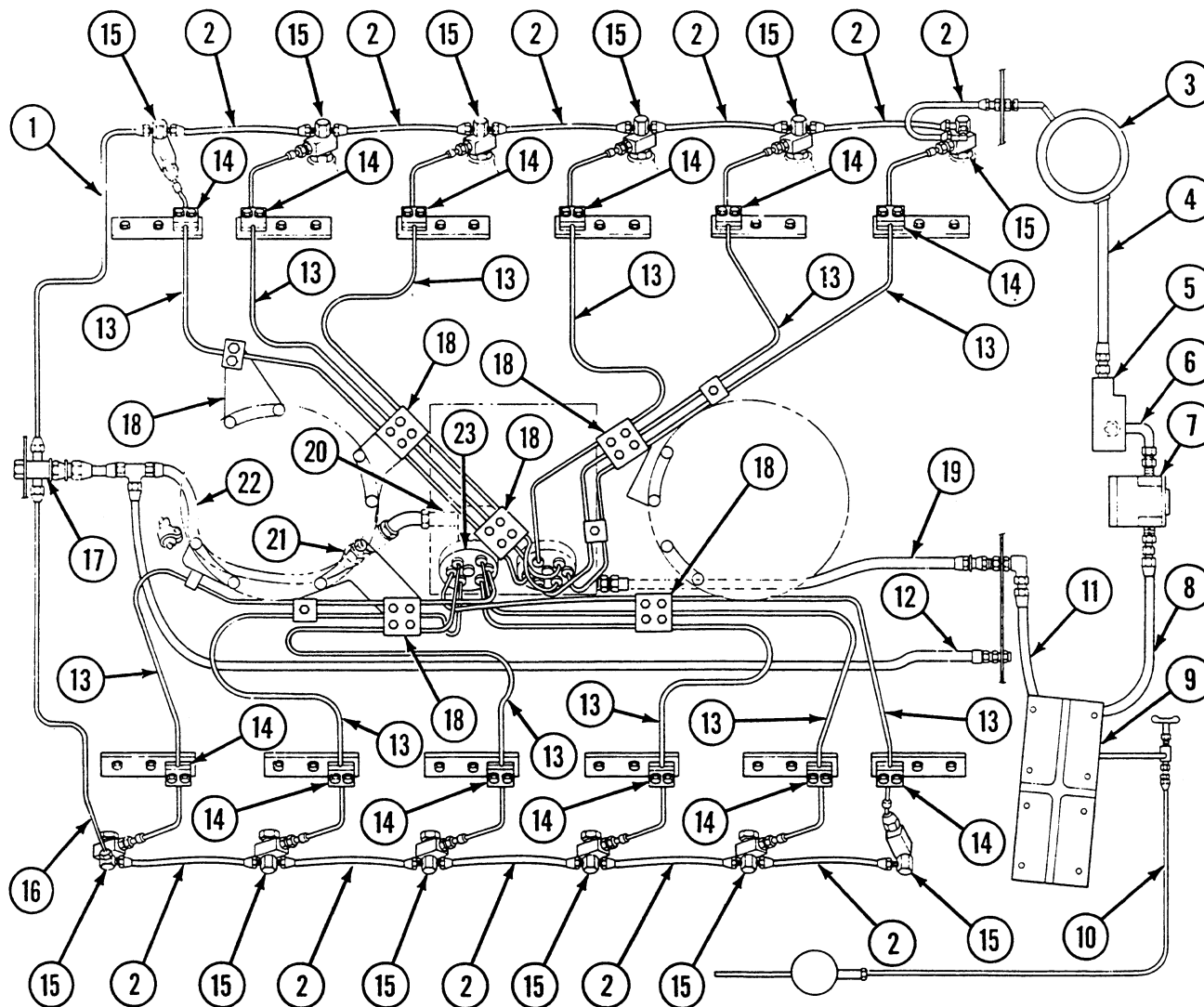

Figure 1. Fuel Supply System.

END OF WORK PACKAGE

UNIT MAINTENANCE
RECOVERY VEHICLE, FULL TRACKED: MEDIUM, M88A1
NSN 2350-00-122-6826, EIC AQA

MANIFOLD AIR INDUCTION HEATER SYSTEM THEORY OF OPERATION

Manifold Air Induction Heater System

The left and right intake manifolds (6 and 9), which distribute supercharged air into each bank of cylinders, are equipped with electrically ignited intake manifold air heaters (2 and 8). The heaters are provided to facilitate engine starting during cold weather.

The purge pump is operated to obtain 90 psi (621 kPa) in the manifold heater fuel lines. Operation of the heater switch on the purge pump handle energizes the manifold heater fuel inlet solenoid valve to allow fuel flow to the heater nozzle. The heater switch also energizes the high-tension coil creating an electrical spark in the manifold, thereby igniting the sprayed fuel. Continued operation of the purge pump is required to maintain fuel pressure and an effective spray pattern into the manifold.

A leakoff line is provided to prevent nozzle fouling and is routed into the injector fuel return line. The fuel is burned in the intake manifold by the ignition of the heater spark plug, which flame-heats the incoming air. This flame-heated air and the products of combustion are fed directly into the cylinders.

The purge pump line connects to a fuel check and pressure relief valve (14) and pressure regulator valve (see item 20, Figure 1, WP 0005 00) in the engine. The fuel check and pressure relief valve prevents purged fuel from returning to the tank or to the purge inlet line.

The fuel check and pressure relief valve (14) ensures the necessary fuel pressure to operate the flame heater spray nozzles (5 and 10). A manifold heater fuel supply solenoid valve (7) and fuel return solenoid valve (16) close the flame heater fuel lines when the flame heater switch is off.

The manifold heater fuel return solenoid valve (16) is located at the rear of the engine. The valve is energized at the same time the ignition unit and heater spark plugs are energized and acts as a check valve to prevent fuel returning from the injector pump and nozzles from entering the heater fuel tubes.

- 1 Left manifold heater ignition unit
- 2 Left manifold air heater
- 3 Spark plug
- 4 Ignition unit electrical lead
- 5 Manifold heater nozzle
- 6 Left intake manifold
- 7 Manifold heater fuel supply solenoid valve
- 8 Right manifold air heater
- 9 Right intake manifold
- 10 Manifold heater nozzle
- 11 Spark plug
- 12 Ignition unit electrical lead
- 13 Right manifold heater ignition unit
- 14 Fuel check and pressure relief valve
- 15 Manifold heater fuel filter
- 16 Manifold heater fuel return solenoid valve

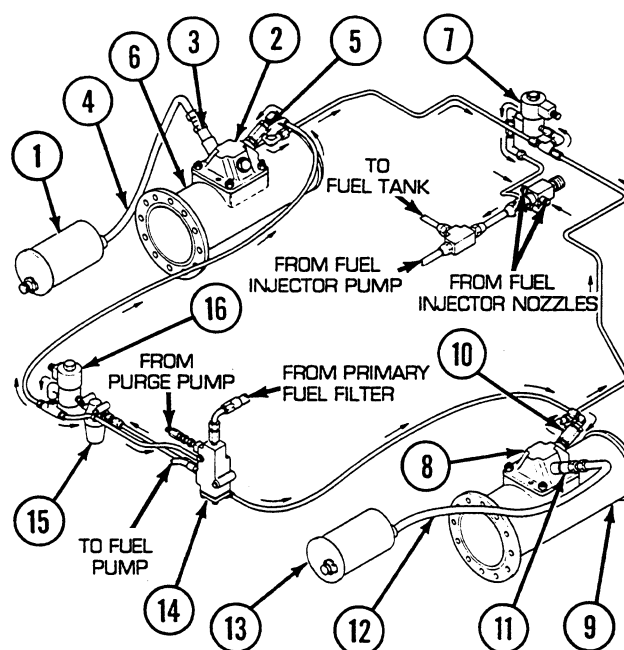

Figure 1. Manifold Air Induction Heater System.

END OF WORK PACKAGE

UNIT MAINTENANCE
RECOVERY VEHICLE, FULL TRACKED: MEDIUM, M88A1
NSN 2350-00-122-6826, EIC AQA

COOLING SYSTEM THEORY OF OPERATION

Cooling System

Air Cooling

Air for cooling enters the engine compartment through the grille doors. The top of the engine is shrouded and encloses two gear-driven, axial-flow cooling fans (1) which draw the air through the cylinder fins and oil coolers and discharge the hot air vertically from the shroud. Sheet metal baffles and deflectors direct the flow of cooling air across the cylinders.

The cooling fans (1) are attached to hubs and are mounted on shafts which are driven by the engine-driven fan drive clutch assembly.

The fan drive shaft and gear shift are driven by a horizontal drive shaft.

The fan clutch is oil cooled. The fan clutch drive and driven disks are loaded by the centrifugal action of clutch balls and springs housed in the clutch assembly. The balls and springs are in the driven member and apply upward force to the clutch disks. The clutch oil enters the fan drive vertical shaft from the fan drive housing through an annular groove in the shaft. The depth of the groove controls the amount of oil flow. The oil flows through a central hole in the shaft to a distributor where it is dispersed to the two ball bearings and the clutch disks. The oil moves between the clutch disks by centrifugal action and drains back through the fan drive housing into the engine oil pan. The fan clutch is designed to slip under deep water fording conditions where the resistance of the water exceeds the friction of the clutch.

- 1 Cooling fans
- 2 Engine oil cooler
- 3 Transmission oil cooler

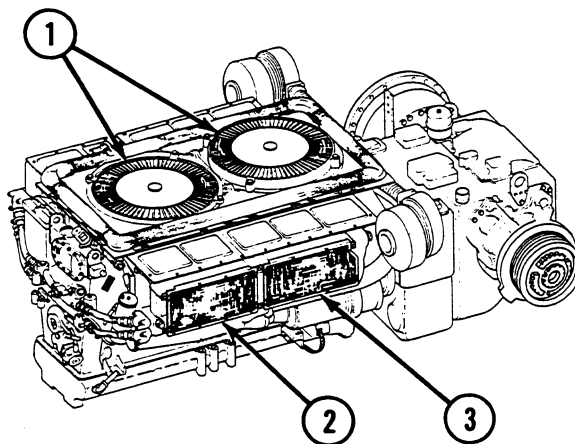

Figure 1. Cooling System.

Oil Cooling

Two engine oil coolers (2) and two transmission oil coolers (3) are mounted on the sides of the engine above the cylinders. The cooling fans (1) draw air through the oil cooler cores to cool the oil being circulated within the coolers.

END OF WORK PACKAGE

UNIT MAINTENANCE**RECOVERY VEHICLE, FULL TRACKED: MEDIUM, M88A1****NSN 2350-00-122-6826, EIC AQA****ELECTRICAL SYSTEMS AND CIRCUITS THEORY OF OPERATION**

Electrical Systems and Circuits**Charging/Starting System and Vehicle Batteries**

1. Engine generator. The generator is an air-cooled, 28-V, dc-rated, 300-A, field-regulated unit. It is mounted on the right side of the engine near the flywheel end, and is gear driven by the engine. An integral blower, an air intake duct, and an outer boot and duct provide a means of cooling the generator. The electrically operated blower draws air from the crew compartment, forces it through the generator, and exhausts it upward through an outlet near the right camshaft gear housing.
2. Generator voltage regulators. The M88A1 has either a single or dual voltage system. In the dual system there are two solid-state generator voltage regulators which maintain generator output voltage at a constant 28 ± 0.7 V dc. One controls the generator voltage output of the engine and the other the generator voltage output of the APU. In the single system, a single voltage regulator controls both the engine and APU generator voltage output. The voltage regulators are mounted at the left rear of the engine compartment.
3. Starter assembly. The 24-V waterproof starter assembly is mounted on the lower left side of the engine toward the rear. It is a heavy-duty, solenoid-operated, enclosed, shift-lever-type engine starter. The motor utilizes 12 brushes retained in 6 brush holders which are accessible through inspection plugs in the motor frame. The drive clutch is a heavy-duty, over-running type with adjustable pinion clearance.
4. Neutral safety switch. The neutral safety switch, mounted on the brake assembly, functions as a safety switch to prevent starting the engine while the transmission shift control is in any shift position other than P (park).
5. Master relay. The master relay is located in the left rear of the engine compartment. It controls primary power to all electrical systems and components with the exceptions of the personnel heater system, the MASTER switch, and the slave receptacle.
6. Batteries. Six 12-V batteries are connected in a series-parallel circuit to give the vehicle a 300-A-hr source of 24-V dc power. The batteries are located in the left side of the engine compartment.

Gage and Switch Panels

1. Gage panel (located to the left of the steering control at the driver's position). The gage panel mounts the following:
 - a. Fuel level gage
 - b. Engine and transmission temperature and pressure gages
 - c. Battery generator indicator
 - d. Speedometer and tachometer
 - e. Mechanical transmission oil pressure warning light
 - f. Master warning light
 - g. Three instrument panel lights
 - h. Fuel selector switch
2. Switch panel (located to the right of the driver's steering control). The switch panel mounts the following:
 - a. Main light switch
 - b. Auxiliary light switch
 - c. Fuel cutoff switch
 - d. Fuel pump switch
 - e. Five circuit breakers
 - f. Master relay indicator light
 - g. MASTER switch
 - h. Blackout (B.O.) selector switch

Sending Units and Warning Indicators

1. Sending units. Sending units for the gage panel are mounted on the engine, transmission, and forward and right rear fuel tanks to indicate the engine and transmission oil temperatures, pressures, and fuel levels.
2. Warning switches. Switches mounted on the engine, transmission, and mechanical transmission indicate, through gage panel lights, the occurrence of engine oil low pressure and high temperature, transmission oil high temperature, and mechanical transmission low oil pressure.
3. Warning indicator lights, gage, and flasher system panel. The panel contains the following components and is located next to the transmission shift lever bracket, adjacent to the driver's seat:
 - a. Fire extinguisher engine shutoff light indicates when the fire extinguisher engine shutoff switch is activated.
 - b. PTO engaged light indicates when the PTO is engaged.
 - c. Flasher system components include an indicator light, switch, flasher unit, and circuit breaker.
4. Hydraulic oil temperature gage and indicator light. These components allow the operator to monitor the temperature of the hydraulic oil during operation of the hydraulic system and warn if a heating problem occurs.

Lighting System

1. Headlight clusters. The right and left headlight clusters each consist of a service headlight, a B.O. service IR headlight, a B.O. drive light, and a B.O. marker light. The headlight assemblies are completely interchangeable; however, the right B.O. drive light is not powered in the B.O. drive condition.
2. Flasher warning light. A flasher warning light with colored lens is controlled through the flasher unit and switch-mounted on the shifting lever mounting bracket in the crew compartment.
3. Dome lights. The dome lights are installed in the crew compartment for interior illumination. The dome light switches provide for either white or colored light as the tactical situation requires.
4. High beam indicator light. A high beam indicator light glows red when the vehicle service drive headlights or IR headlights are changed to high beam through the driver's dimmer switch.
5. Winch compartment light. The winch compartment light is operated by a switch on the accessories panel and illuminates the hoist winch, main winch, and surrounding areas in the winch compartment.
6. Rigger's fixed spotlight. The rigger's fixed spotlight is controlled by a handle that extends through the roof into the rigger's area in the crew compartment.
7. Rigger's service light assembly. The rigger's service light assembly, controlled by the rigger's light selector switch, projects a high beam.
8. Rigger's B.O. light. The rigger's B.O. light is controlled by the rigger's light selector switch and projects a high beam.
9. Taillight assemblies. The right taillight assembly consists of the B.O. marker taillight. The left taillight assembly consists of the service taillight, service stoplight, and B.O. marker light.

10. Troublelight assembly. The troublelight assembly is a portable, hand-held light with a reeled, 25-ft (7.6-m) extension cord.
11. Driver's passive night viewer switch and light. The driver's passive night viewer is controlled by the switch, and the light indicates when the night viewer is activated.

Miscellaneous Electrical Components

1. Rigger's light selector switch. The rigger's light selector switch contains a three-position toggle switch that controls the operation of the rigger's service and IR light.
2. Accessories panel. The accessories panel contains the accessory outlet socket, a two-position winch light toggle switch, a two-position ventilating blower toggle switch, a two-position bilge pump toggle switch, a two-position generator toggle switch, a bilge pump lamp, and a generator lamp.
3. Ventilating blower. An electric motor driven ventilating blower draws fresh air from outside the vehicle into the crew compartment for ventilation.

Conduits, Cables, and Connectors

1. Conduits. Flexible, metallic conduits are used on high-voltage cables to prevent electrical radiation which might interfere with communications equipment.
2. Cables. Electrical cables are rubber covered. The ends of all cables terminate in a pin or socket on a connector, plug, or receptacle, or at a cable terminal. The cables are crimped or soldered to the pins, sockets, terminals, or ferrules.
3. Plug and receptacle-type connectors. The plug has four main components: the shell assembly, coupling nut, grommet, and retaining nut. The receptacle has three components: the receptacle assembly, grommet, and retaining nut. The receptacle is secured to a box or panel with four screws. The plug is secured to the receptacle with the coupling nut. A waterproof connection is made with the retaining nut by compressing the grommet to the ends of the plug or shell assemblies. The shell and receptacle assemblies have either pins or sockets for one or many electrical connections.
4. Waterproof rubber connectors. Each connector has a male and female component. The female portion consists of a rubber shell, sleeve, and ferrule. The male part consists of a rubber shell, C-washer, and terminal. The friction-fit union of the two halves forms a waterproof connection.

END OF WORK PACKAGE

UNIT MAINTENANCE
RECOVERY VEHICLE, FULL TRACKED: MEDIUM, M88A1
NSN 2350-00-122-6826, EIC AQA

TRANSMISSION AND OUTPUT REDUCTION DRIVES THEORY OF OPERATION

Transmission and Output Reduction Drives

General

The cross-drive transmission (3) is a combined transmission with steering unit and two output reduction drives (1 and 2). It transmits power directly from the engine to the track drive sprockets. The transmission is controlled by the vehicle operator by means of the shifting and steering controls and linkages, and the brake control pedal linkage.

The cross-drive transmission (3) includes a hydraulic torque converter, a split torque drive, variable steering, and disk-type brakes. The transmission delivers engine power to the track sprockets at an output torque which varies automatically according to the driven-load conditions when not in linkup.

There are three forward speed ranges and one reverse.

Steering is possible in all drive ranges and N (neutral). Steering in N (neutral) causes the vehicle to pivot in place, with the tracks turning in opposite directions.

- 1 Right output reduction drive
- 2 Left output reduction drive
- 3 Cross-drive transmission

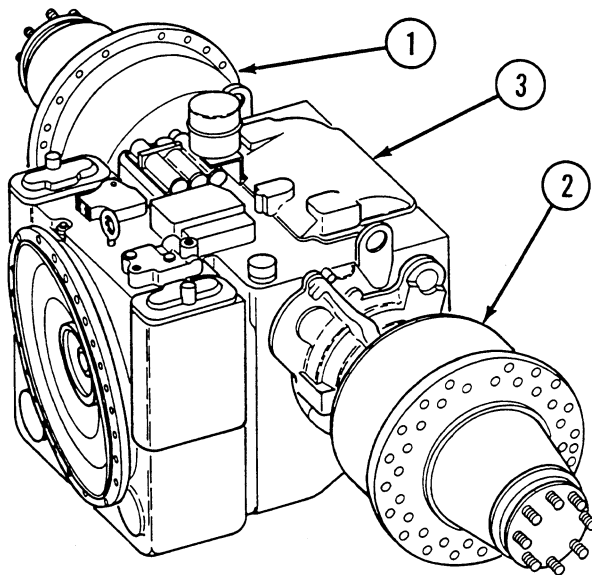

Figure 1. Transmission and Output Reduction Drives.

Hydraulic and Lubrication System

Functions:

1. Applies force for clutch ranges
2. Power transmitting medium in torque converter
3. Lubricant for entire transmission
4. Cooling medium for entire transmission

END OF WORK PACKAGE

UNIT MAINTENANCE
RECOVERY VEHICLE, FULL TRACKED: MEDIUM, M88A1
NSN 2350-00-122-6826, EIC AQA
TRACKS AND SUSPENSION SYSTEMS THEORY OF OPERATION

Tracks and Suspension Systems

The suspension system on each side of the vehicle consists of six pairs of individually sprung roadwheels (1), three track support rollers (2), a compensating idler wheel (3), a compensating idler link (4), a track drive hub and sprocket (5), and a track (6).

- 1 Roadwheels
- 2 Track support rollers
- 3 Compensating idler wheel
- 4 Compensating idler link
- 5 Track drive hub and sprocket
- 6 Track

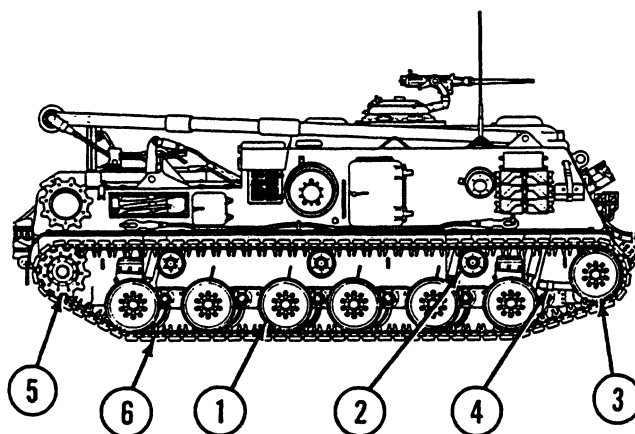

Figure 1. Tracks and Suspension Systems.

Primary springing is accomplished by individual torsion bars for each roadwheel. Secondary springing is accomplished by dual volute bumper springs on numbers 1 and 6 roadwheels. Bump stop brackets are welded to the hull over roadwheel numbers 2 through 5 to limit torsion bar windup beyond allowable limits.

Shock absorbers are attached between the first, second, and sixth roadwheel arms and the hull on each side of the vehicle. Each track consists of 84 rubber shoe assemblies. The individual links are held together by end connectors and wedges, guides, and guide caps. The guides ride between the dual wheels and through a trough in the track drive sprocket hub to maintain track alignment.

END OF WORK PACKAGE

UNIT MAINTENANCE
RECOVERY VEHICLE, FULL TRACKED: MEDIUM, M88A1
NSN 2350-00-122-6826, EIC AQA
FIXED FIRE EXTINGUISHER SYSTEM THEORY OF OPERATION

Fixed Fire Extinguisher System

The M88A1 is equipped with a fixed, carbon dioxide, fire extinguisher system for smothering fires in the engine and winch compartments. The system consists of eight 10-lb (4.5-kg) cylinders (1), a cylinder control valve (2), remote control connectors (3), two dual-pull mechanisms (4), extinguisher lines, seven nozzles, two exterior remote control pull handles (5) with cables, two interior remote control pull handles (6) with cables, and an engine shutoff switch (7) (to ensure the engine is turned off before the fixed fire extinguishers are discharged). Each cylinder is equipped with a safety valve that automatically discharges when pressure becomes excessive due to heat. The cylinders are mounted in banks of four on each side of the cab interior.

- 1 Cylinder
- 2 Cylinder control valve
- 3 Remote control connectors
- 4 Dual-pull mechanism
- 5 Exterior remote control pull handles
- 6 Interior remote control pull handles
- 7 Engine shutoff switch

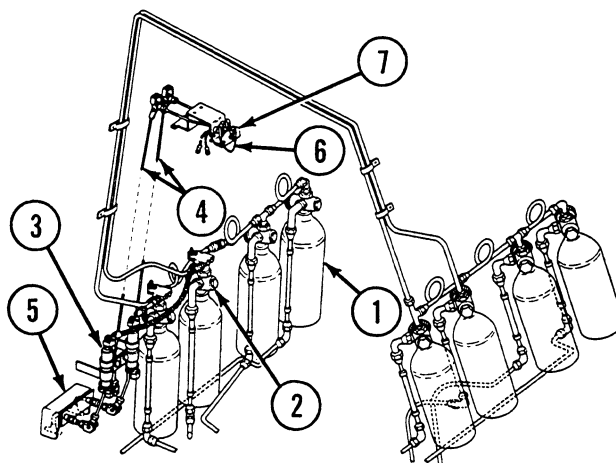

Figure 1. Fixed Fire Extinguisher System.

The engine shutoff switch (7) consists of a push button switch assembly (electrically connected in series with the engine fuel shutoff solenoid and the vehicle batteries), which is depressed (open circuit) during vehicle operation by an adjustable screw mounted on a hinged metal shield held in position by a quick-release pin. When it is necessary to discharge the fire extinguisher system, the push button on the quick-release pin is depressed, allowing the shield to pivot downward, which releases the adjustable screw from the push button on the switch assembly and activates the fuel shutoff solenoid, shutting off the engine.

END OF WORK PACKAGE

UNIT MAINTENANCE
RECOVERY VEHICLE, FULL TRACKED: MEDIUM, M88A1
NSN 2350-00-122-6826, EIC AQA

WINCHES, SPADE ASSEMBLY, AND HOISTING BOOM THEORY OF OPERATION

Winches, Spade Assembly, and Hoisting Boom

Main Winch

The main winch (1) is mounted to the nosepiece of the vehicle beneath the crew compartment. It is gear-driven by a hydraulic motor and is used for heavy-duty recovery operations. The winch is wound with 200 ft (61.0 m) of 1-1/4 in. (31.8 mm) steel cable. The cable is equipped with a clevis on the free end for securing it to loads.

Spade Assembly

The spade (2) is mounted to the vehicle nosepiece by two trunnion-mounted arms. The arms are operated by hydraulic cylinders (3) from within the winch compartment. When not in use, the spade is secured in a raised position by a hydraulically activated, spring-loaded spade lock.

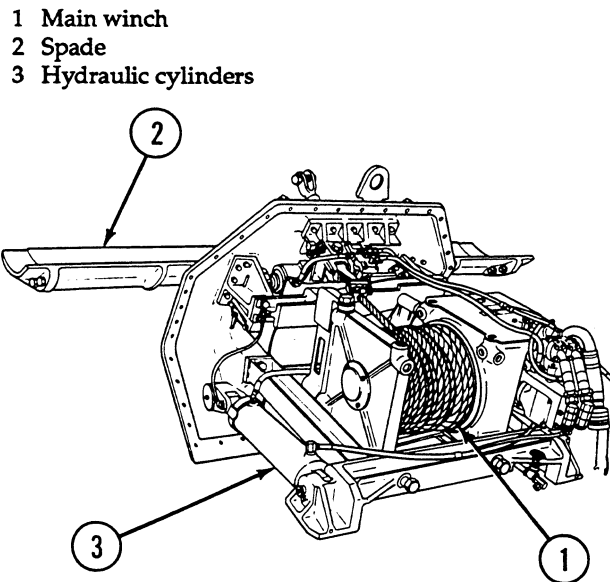

Figure 1. Main Winch and Spade Assembly.

Hoist Winch

The hoist winch is mounted in the winch compartment and is gear-driven by a hydraulic motor. The winch is capable of hoisting a maximum load of 50,000 lb (22,680 kg) with a four-part line, using a 5/8-in. (15.88-mm) steel cable. The hoist winch is wound with 200 ft (61.0 m) of this steel cable.

Hoisting Boom

The hoisting boom is a tubular, modified A-frame, and is pivot-mounted to the top front of the vehicle. The boom is raised or lowered by two hydraulically operated boom cylinders. In operating position, the boom is supported by a stayline cable secured to crankarms located at the rear of the hull. The crankarms control the live-boom movement by means of hydraulically operated stayline cylinders. In lowered position, the boom is secured on the boom support assembly by a boom travel lock. The hoisting boom is used in conjunction with the hoist winch.

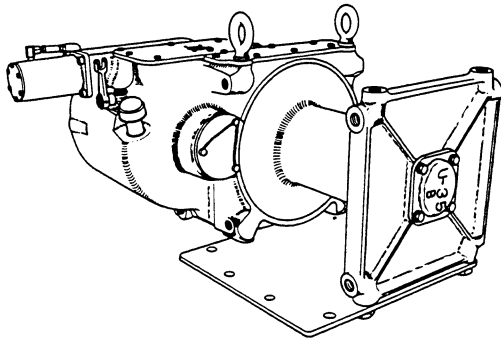

HOIST WINCH

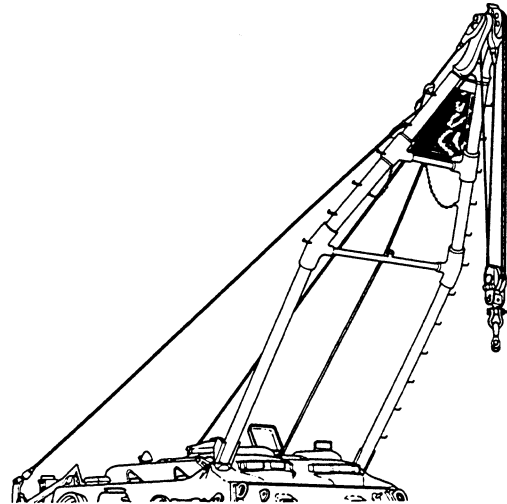

HOISTING BOOM

Figure 2. Hoist Winch and Hoisting Boom.

END OF WORK PACKAGE

UNIT MAINTENANCE
RECOVERY VEHICLE, FULL TRACKED: MEDIUM, M88A1
NSN 2350-00-122-6826, EIC AQA

MECHANICAL TRANSMISSION AND MAIN HYDRAULIC SYSTEM PUMP THEORY OF OPERATION

Mechanical Transmission and Main Hydraulic System Pump

The mechanical transmission and hydraulic pump assembly is mounted in the rear of the hydraulics compartment, under the crew compartment subfloor plates. The engine drives the mechanical transmission (1) through the PTO drive shaft coupled to the PTO coupling at the accessory end of the engine. The mechanical transmission drives the main hydraulic system pump (2). The pump provides hydraulic system pressure.

- 1 Mechanical transmission
- 2 Main hydraulic system pump

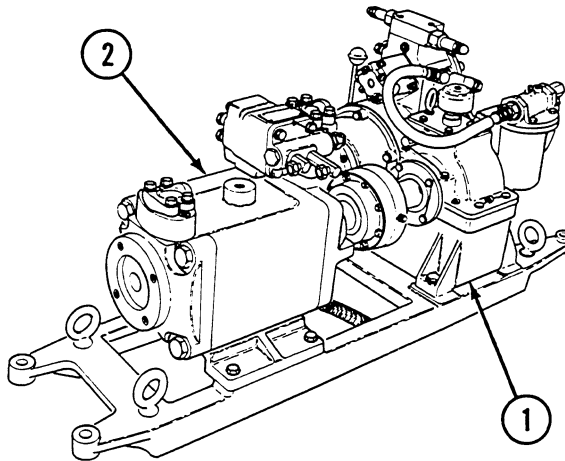

Figure 1. Mechanical Transmission and Main Hydraulic System Pump.

END OF WORK PACKAGE

UNIT MAINTENANCE
RECOVERY VEHICLE, FULL TRACKED: MEDIUM, M88A1
NSN 2350-00-122-6826, EIC AQA
MAIN HYDRAULIC SYSTEM THEORY OF OPERATION

Main Hydraulic System

The main hydraulic system supplies power for the control and operation of the spade, hoisting boom, hoist winch, and main winch, and for releasing the mechanically applied main and hoist winch brakes. System power is obtained from the main hydraulic pump driven by the mechanical transmission.

END OF WORK PACKAGE

UNIT MAINTENANCE
RECOVERY VEHICLE, FULL TRACKED: MEDIUM, M88A1
NSN 2350-00-122-6826, EIC AQA
AUXILIARY POWER UNIT (APU) THEORY OF OPERATION

APU**General**

The APU consists of an overhead-valve, two-cylinder, four-cycle, air-cooled, diesel engine connected directly to a 300-A, 28-V, shunt-wound, dc generator (which is also used as a starter), and an auxiliary hydraulic system pump. The APU provides electrical power to charge the vehicle batteries, and hydraulic power to raise and lower the spade, stow and raise the boom, and retrieve the main and hoist winch cables.

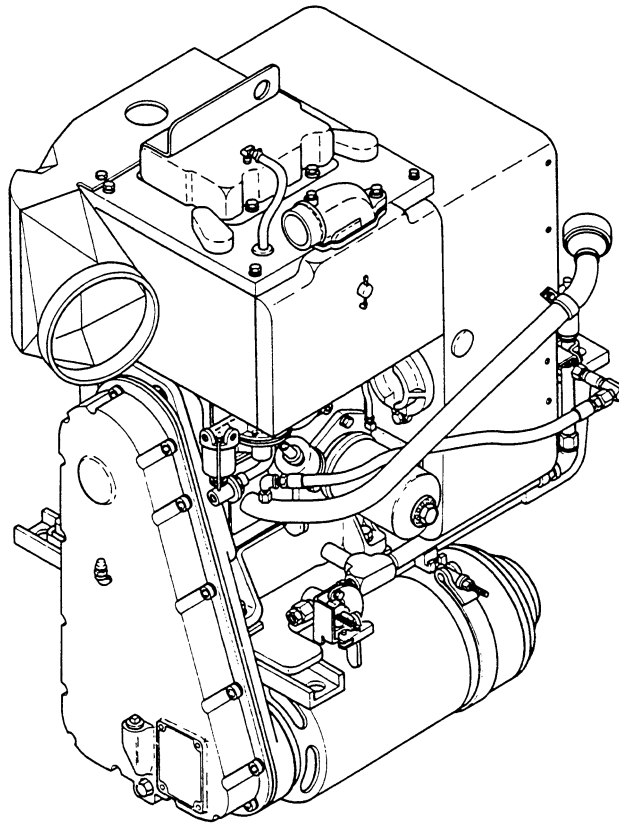

Figure 1. APU.

Starting and Generating Systems

The 300-A, 28-V generator mentioned above is also used as a starter motor. This is accomplished by first feeding 24 V dc to the field coil of the generator from the preheat relay when the preheat switch is activated, and then by applying 24 V dc to the generator armature through a starting relay when the start switch is activated. This motorizes the generator, which is directly coupled to the engine by a drive chain. When the engine starts, the current in the generator armature reverses direction, and the system automatically changes from a motorizing mode to a generating mode. After the engine starts, the start and preheat switches must be released to prevent loading down the engine since the voltage regulator is bypassed during this start cycle, and full voltage is being applied to the field. After the engine has started, and the preheat and start switches are released, the generator output is controlled by a solid-state voltage regulator and a current-limiting device.

Lubrication

A gear-type pump draws oil from the crankcase and delivers it through a replaceable oil filter to the engine. Normal oil pressure should be 25 psi (172 kPa) or higher under normal operating conditions. A crankcase oil drain valve with operating handle is provided to drain the lubricating oil without removing the unit from the vehicle.

Governor

Constant speed is set to maintain engine speed at 2000 ± 100 rpm. The governor uses a ball-and-cup mechanism on the camshaft gear as the sensing device. A yoke resting on the cup connects to an arm-and-spring mechanism controlling the throttle lever. Any change in engine speed is transmitted from the cup to the yoke and to the throttle. The speed may be adjusted by changing the spring tension.

Fuel System

The fuel system consists basically of a primary and secondary fuel filter, fuel transfer pump, injection pump, and injection nozzle. The transfer pump, operating off the camshaft, draws fuel from the supply tank and delivers it through the two filters to the injection pump. The injection pump meters and delivers the fuel at high pressure to the nozzle.

END OF WORK PACKAGE

UNIT MAINTENANCE
RECOVERY VEHICLE, FULL TRACKED: MEDIUM, M88A1
NSN 2350-00-122-6826, EIC AQA
M8A3 GAS/PARTICULATE FILTER UNIT (GPFU) THEORY OF OPERATION

M8A3 GPFU

The GPFU installation in the M88A1 vehicle is made up of two separate M8A3 systems. One M8A3 GPFU serves the personnel on the left side of the vehicle and is operated by the driver. The other M8A3 GPFU serves the commander, mechanic, and rigger with the control switch located at the mechanic's station. Electrical power for operation of the purifier units is obtained by tapping into convenient dome light power leads.

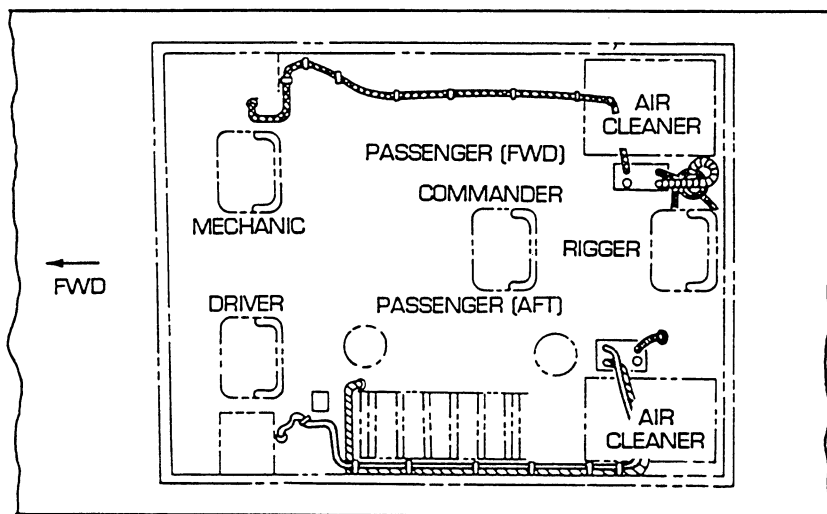

Figure 1. M8A3 GPFU.

END OF WORK PACKAGE

UNIT MAINTENANCE
RECOVERY VEHICLE, FULL TRACKED: MEDIUM, M88A1
NSN 2350-00-122-6826, EIC AQA

M239 SMOKE GRENADE LAUNCHER SYSTEM THEORY OF OPERATION

M239 Smoke Grenade Launcher System

The M239 smoke grenade launcher system consists of two smoke grenade dischargers (1), canvas covers, a push button firing switch at the commander's station, two smoke grenade stowage boxes, and an electrical installation kit composed of a power (arming) switch box, mounting bracket, electrical wiring harnesses, and connectors.

The power (arming) switch box is mounted on a bracket attached to the cab top near the commander's cupola. Electrical wiring harnesses connect the power switch box to the push button firing switch, dischargers, and vehicle current source. The power switch box consists of an on/off switch to control the power supply to the firing switch, and an indicator lamp to show the presence of electrical power.

1 Smoke grenade dischargers

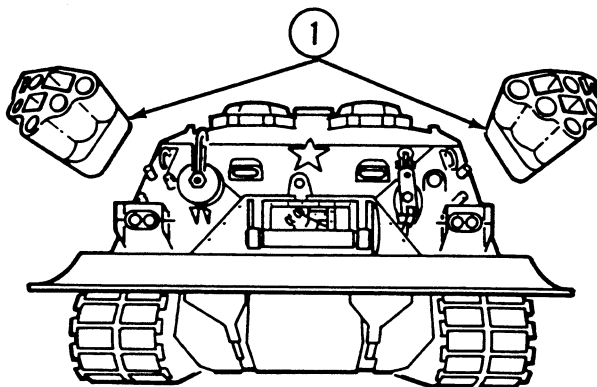

Figure 1. M239 Smoke Grenade Launcher System.

END OF WORK PACKAGE

UNIT MAINTENANCE
RECOVERY VEHICLE, FULL TRACKED: MEDIUM, M88A1
NSN 2350-00-122-6826, EIC AQA
EXHAUST SMOKE GENERATING SYSTEM THEORY OF OPERATION

Exhaust Smoke Generating System

The exhaust smoke generating system consists of solenoid valves, switch assemblies, shutoff valve, indicator light, mounting brackets, fuel hose assemblies, electrical leads, and attaching parts.

The solenoid valves and fuel tube assemblies are attached to the rear of the engine. Fuel to operate the smoke generating system is taken from the main fuel supply at the front of the engine.

The switch (1) to operate the smoke generating system is installed in the driver's compartment and the commander's station, and is connected to the main wiring harness using electrical leads provided in the smoke generating system kits.

The smoke generating system uses the engine fuel pump to supply diesel fuel, from the vehicle fuel tanks, to two solenoid valves mounted at the rear of the engine. When the solenoid valves are energized (opened), they allow diesel fuel to be sprayed into the exhaust system. The fuel vaporizes and exits together with the engine exhaust gases. The fuel vapor cools on contact with the moving exhaust air and condenses to form a dense smoke screen. The electrical power to energize the solenoid valves is supplied by the warning indicator and warning horn systems. The warning horn will not sound unless the engine is running, and connection to this system prevents accidental activation of the smoke generating system when the engine is not running.

The manual fuel shutoff valve can be used to determine if the smoke produced is from a malfunctioning engine, or from the smoke generating system.

1 Switch

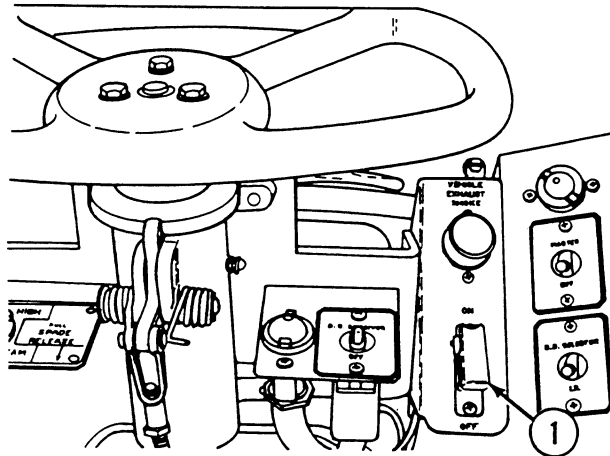

Figure 1. Exhaust Smoke Generating System.

END OF WORK PACKAGE

UNIT MAINTENANCE
RECOVERY VEHICLE, FULL TRACKED: MEDIUM, M88A1
NSN 2350-00-122-6826, EIC AQA
DEEP WATER FORDING KIT THEORY OF OPERATION

Deep Water Fording Kit

General

The deep water fording kit as installed on the M88A1 permits fording to a maximum depth of 8 ft, 6 in. (2.59 m). The design of the deep water fording equipment permits the vehicle to be completely operable on land or in water, providing maximum depth is not exceeded.

Engine Exhaust

The engine exhaust system for deep water fording consists of a series of pipes to provide the proper venting of the exhaust for the right and left banks of the engine. A flexible, bellowed-type pipe is clamped to the engine exhaust outlet. Utilizing a slip joint, each pipe is attached to the main engine exhaust pipe, which ducts the exhaust gases through the rear engine deck. To each engine exhaust pipe, a 4-1/2 in.- (114 mm-) diameter pipe, which extends above the specified depth, is clamped and sealed. Two clamps, bolted to the engine deck, are used to hold the system in proper position.

Engine Air Inlet

The engine air inlet system provides for the use of outside air for the engine while the vehicle is in the water. The system consists of two pipes and two rubber seals, which cover and seal each of the air intake vents on the top of the vehicle cab.

Engine Generator Cooling Exhaust

The engine generator electrical output is switched off and the valve assembly closed by the driver from the crew compartment to prevent water from entering the generator.

APU

Preparations and precautions are taken before and after submersion of the APU to prevent corrosion and separation of hot leads due to electrolysis by exposure to salt water, and the destruction of the brushes, brush holders, and armature by sand.

Personnel Heater

The personnel heater is not operable during fording operations. The air inlet and exhaust outlets are plugged during fording operations and unplugged after fording operations.

Acetylene Compartment Vent

A vent assembly consisting of tubing, fittings, adapter plate, and gasket is attached to a boss which surrounds the four vent holes in the left rear of the cab, to provide ventilation of the compartment during the deep water fording operation. Two clips mounted onto the left engine air intake pipe support the vent system.

Fuel Tank Vent

Two 90-degree elbows, a rubber hose, two hose clamps, a seal, and a clip are the components used to vent the fuel tanks. The rubber hose is clamped to an elbow in the left engine air intake pipe and to an elbow in the fuel tank's filler cover. The seal is installed between the bottom of the fuel tank filler cover and the top of the fuel tank filler cap to prevent entry of water. The clip, attached to the acetylene vent cover, keeps the hose from hanging free and being torn.

Bilge Pump, Motor, and Support Assembly

A centrifugal-type bilge pump with motor and support assembly is installed on the hull floor in the winch compartment. The pump is used to remove any water which may enter the compartment during fording. The discharge of the pump is directed through the bilge pump hose to an outlet adapter, mounted onto the right side of the personnel compartment. A multiple purpose (wash vehicle, etc.), dacron rubber-lined hose with nozzle can be attached to the outlet adapter. A toggle switch and indicator lamp for operating the pump are located at the right of the driver's seat on the accessories panel. A relay, which is activated by the toggle switch, controls the pump motor. A circuit breaker mounted under the floor plates and on the same plate as the relay provides overload protection for the pump circuit. The switch and relay coil circuit is protected by a circuit breaker in the accessories panel.

Crew Fan Air Duct Housing and Boom Boot Drains

A rubber seal between two metal plates fits into and seals the crew fan air duct housing. Shutoff hose clamps are used to control water flow from the crew fan air duct housing and boom boot drains.

Fire Extinguisher System

Seven rubber fire extinguisher nozzle caps protect the extinguisher system from the entrance of water and contaminants. These caps are not sealed and would be blown off from the nozzles upon release of the system.

Sealing and Miscellaneous Materials

Nonhygroscopic tape is applied around the transmission oil filler neck, and to excessively large open areas if required.

Fording sealer is used as a sealing compound around exterior stowage compartment doors, main winch cable opening, removable hull front cover, and all mounting surfaces of the vehicle and deep water fording components.

Electrical insulating and sealing compound is used to seal all exposed electrical connections except battery terminals.

Asbestos sealing compound is used to seal battery terminals.

Wiping cloths are supplied to be used in cleaning and drying the vehicle preparatory to sealing.

Spanner wrenches are provided for installing multipurpose hose.

END OF WORK PACKAGE

UNIT MAINTENANCE**RECOVERY VEHICLE, FULL TRACKED: MEDIUM, M88A1****NSN 2350-00-122-6826, EIC AQA****RADIO INTERFERENCE SUPPRESSION THEORY OF OPERATION**

Radio Interference Suppression

Radio interference suppression is the elimination or minimizing of electrical disturbances which interfere with radio reception or disclose the location of the vehicle to sensitive electronic detectors. It is important, therefore, that all vehicles be suppressed properly to prevent interference with radio reception by the same vehicle, neighboring vehicles, or installations. Essentially, suppression is attained by providing a low-resistance path to ground for stray currents. The methods used include shielding the ignition and high-frequency wires, grounding the frame with bonding straps, and using capacitors and resistors.

Interference Suppression Components

1. Preheat system.
 - a. High-tension cable. The high-tension cable to the spark plug preheater consists of an inner conductor which carries the high voltage to the spark plug, and an outer braided conductor which serves as a shield and also grounds the metal exciter housing to the spark plug housing. The exciter housing is also grounded to the vehicle engine through one of the leads (connected to terminal B) in the exciter power input cable.
 - b. Spark plug. The spark plug is integrally shielded and contains an integral resistor-suppressor.
2. Generating systems. The engine generator and auxiliary engine generator are radio interference suppressed in an identical manner by use of feedthrough capacitors. These feedthrough capacitors are mounted on and extend through the side of the junction box mounted on the generators. The mounting frames of the capacitors are grounded to the box by means of tooth-type lockwashers. The armature circuit capacitor valve is 1.75 microfarads (mfd), and rated at 100 V dc at 300 A. The field and interpole circuit capacitors are both 0.25 mfd, and rated at 100 V dc at 10 A. The blower attached to the engine generator also has a 0.25-mfd, 100-V dc, 20-A, feedthrough capacitor in series with each power lead.
3. Personnel heater. The personnel heater fuel pump is integrally suppressed by means of a feedthrough capacitor. A 0.25-mfd, 100-V dc, 20-A, feedthrough capacitor mounted on the motor housing is in series with the blower motor positive power input lead.
4. Ventilating blower. A 0.1-mfd, feedthrough capacitor mounted in the motor housing is inserted in series with the power input lead of the blower. The power input lead between the blower and input power connector is also shielded with braided cable.
5. Roadwheels, track support rollers, and idler wheels. Static grounding springs are included in the roadwheels and track support rollers. These coil steel springs function as grounding devices for static electricity developed by the wheels and rollers when the vehicle is in motion.

Other Means

Feedthrough capacitors require good bonding or grounding to provide adequate radio noise suppression. Tinned copperbraid bond straps, terminated in appropriate copper lugs and bonded by means of plated tooth-type lockwashers, are used for this purpose when good contact between the component to be suppressed and ground is required. Where clearance is not a problem and the component is mounted with bolts or other fasteners, plated tooth-type lockwashers are used to provide the grounding.

END OF WORK PACKAGE

CHAPTER 2
UNIT MAINTENANCE
TROUBLESHOOTING PROCEDURES
FOR
RECOVERY VEHICLE, FULL TRACKED: MEDIUM, M88A1
(NSN: 2350-00-122-6826)

CHAPTER 2
UNIT MAINTENANCE
TROUBLESHOOTING PROCEDURES

WORK PACKAGE INDEX

<u>Title</u>	<u>WP Sequence No.</u>
Troubleshooting Index.....	0021 00
Engine Troubleshooting Procedure	0022 00
Fuel, Air Intake, and Exhaust Systems Troubleshooting Procedure.....	0023 00
Oil Cooling System Troubleshooting Procedure.....	0024 00
Ventilation Blower Assembly Troubleshooting Procedure.....	0025 00
Transmission Center Section and Output Reduction Gears Troubleshooting Procedure.....	0026 00
Driver’s Controls Troubleshooting Procedure.....	0027 00
Tracks and Suspension Troubleshooting Procedure.....	0028 00
Mechanical Transmission Troubleshooting Procedure.....	0029 00
Main Winch Troubleshooting Procedure.....	0030 00
Hoist Winch Troubleshooting Procedure.....	0031 00
Hoisting Boom Troubleshooting Procedure.....	0032 00
Spade Troubleshooting Procedure.....	0033 00
Main Hydraulic System Troubleshooting Procedure.....	0034 00
Auxiliary Hydraulic System Troubleshooting Procedure.....	0035 00
APU Troubleshooting Procedure.....	0036 00
Main Hydraulic Pump Troubleshooting Procedure.....	0037 00
Auxiliary Hydraulic Pump Troubleshooting Procedure.....	0038 00
Mechanical Transmission—Hydraulic Troubleshooting Procedure.....	0039 00
Simplified Test Equipment/Internal Combustion Engine-Reprogrammable (STE/ICE-R) Trou- bleshooting Procedure.....	0040 00
Battery Power Circuit Troubleshooting Procedure.....	0041 00
Master Relay and Slave Receptacle Troubleshooting Procedure.....	0042 00
Engine Starting System Troubleshooting Procedure.....	0043 00
Engine Manifold Preheater System Troubleshooting Procedure.....	0044 00
Engine Fuel Shutoff Solenoid Troubleshooting Procedure.....	0045 00
Fire Extinguisher Engine Shutoff Light Troubleshooting Procedure.....	0046 00
Electric In-Tank Fuel Pump Troubleshooting Procedure.....	0047 00
Fuel Gage Troubleshooting Procedure.....	0048 00
Engine Oil Temperature Gage Troubleshooting Procedure.....	0049 00
Engine Oil Pressure Gage Troubleshooting Procedure.....	0050 00
Power Control Lever Switch Troubleshooting Procedure.....	0051 00
Transmission Oil Temperature Gage Troubleshooting Procedure.....	0052 00
Transmission Oil Pressure Gage Troubleshooting Procedure.....	0053 00
Engine Generator (Dual Voltage) Troubleshooting Procedure.....	0054 00
Engine Generator (Single Voltage) Troubleshooting Procedure.....	0055 00
APU Generator System (Dual Voltage) Troubleshooting Procedure.....	0056 00
APU Generator System (Single Voltage) Troubleshooting Procedure.....	0057 00
Generator Indicator Gage Troubleshooting Procedure.....	0058 00
APU Starting System Troubleshooting Procedure.....	0059 00
APU Fuel Solenoid System Troubleshooting Procedure.....	0060 00
APU Low Oil Pressure System Troubleshooting Procedure.....	0061 00
APU High Air Temperature System Troubleshooting Procedure.....	0062 00
APU Engine Oil Pressure Gage Circuit Troubleshooting Procedure.....	0063 00
Mechanical Transmission Oil Pressure Light Troubleshooting Procedure.....	0064 00
Master Warning Light Troubleshooting Procedure.....	0065 00

CHAPTER 2
UNIT MAINTENANCE
TROUBLESHOOTING PROCEDURES

WORK PACKAGE INDEX—Continued

<u>Title</u>	<u>WP Sequence No.</u>
Powerplant Warning Horn Troubleshooting Procedure.....	0066 00
External Vehicle Warning Horn Troubleshooting Procedure.....	0067 00
Bilge Pump System and Electrical Accessories Panel Power Outlet Troubleshooting Procedure.....	0068 00
Personnel Heater Control System Troubleshooting Procedure.....	0069 00
Communication System Troubleshooting Procedure.....	0070 00
Dome Lights Troubleshooting Procedure.....	0071 00
Passive Night Viewer Troubleshooting Procedure.....	0072 00
Driver's Periscope Troubleshooting Procedure.....	0073 00
Fixed Spotlight Troubleshooting Procedure.....	0074 00
Troublelight Assembly Troubleshooting Procedure.....	0075 00
Winch Light Troubleshooting Procedure.....	0076 00
Gage Panel Lights Troubleshooting Procedure.....	0077 00
Service Headlights Troubleshooting Procedure.....	0078 00
High Beam Indicator Troubleshooting Procedure.....	0079 00
Service Stoplight Troubleshooting Procedure.....	0080 00
B.O. Service Condition (IR Headlights) Troubleshooting Procedure.....	0081 00
B.O. Service Condition (B.O. Stoplight) Troubleshooting Procedure.....	0082 00
B.O. Marker Condition Troubleshooting Procedure.....	0083 00
B.O. Drive Condition Troubleshooting Procedure.....	0084 00
Rigger's Lights and Front Signal Light Troubleshooting Procedure.....	0085 00
Ventilation Blower System Troubleshooting Procedure.....	0086 00
Engine Generator Blower Motor Troubleshooting Procedure.....	0087 00
M8A3 Filter Unit System Troubleshooting Procedure.....	0088 00
M239 Smoke Grenade Launcher System Troubleshooting Procedure.....	0089 00
Hydraulic Reservoir Monitoring System Switches and Lights Troubleshooting Procedure.....	0090 00
Hydraulic Reservoir Monitoring System Gage Transmitter Troubleshooting Procedure.....	0091 00
Exhaust Smoke Generating System Troubleshooting Procedure.....	0092 00
Fuel/Water Separator Control Module System Troubleshooting Procedure.....	0093 00

UNIT MAINTENANCE
RECOVERY VEHICLE, FULL TRACKED: MEDIUM, M88A1
NSN 2350-00-122-6826, EIC AQA
TROUBLESHOOTING INDEX

General Instructions

The Troubleshooting Index is the master reference table for locating troubleshooting information. This Index contains a list of various malfunctions which may occur during operation or inspection of the M88A1 and provides a reference to information located within the appropriate Troubleshooting Work Package. Each Troubleshooting Work Package provides step-by-step instructions for isolating and correcting malfunctions.

STE/ICE Troubleshooting

When a malfunction is recognized on the engine, transmission or hydraulic systems of the M88A1 the Troubleshooting Index may reference STE/ICE-R method for analyzing the malfunction. The STE/ICE-R method will be the primary troubleshooting procedure when referenced; the backup procedure should be used only when STE/ICE-R is unavailable.

Electrical Troubleshooting

Work Packages dealing with electrical troubleshooting include schematic diagrams to give insight to the harnesses involved. See Hull Wiring Diagram (see fold-out illustration at back of this manual) for complete wiring of the entire vehicle.

WARNING

Ensure MASTER switch is OFF between every step unless otherwise directed throughout troubleshooting of the electrical system or electrical components. Remove all jewelry and metal objects when working on electrical systems to prevent injury due to electrical shock.

WARNING

Certain precautions must be observed before beginning any tests on the 24-V system. Do not permit a hot wire to touch metal parts of the vehicle at any time. Flash testing by striking a hot wire against a vehicle ground will cause an arc that will completely destroy the connector on the lead. Accidental contact of metal tools between battery or starter cables and frame of vehicle causes a direct circuit resulting in arcing of tools. This can cause serious damage to tools, vehicle components, and batteries. Overloaded batteries may explode, spraying hot acid and sharp fragments over surrounding area. The correct procedure when removing electrical equipment, harnesses, battery cables, or starting cables is to turn off the MASTER switch and disconnect battery ground cable. Protect ground cable from accidental contact with battery terminal. When work has been completed, connect battery ground cable last.

The multimeter is used throughout electrical troubleshooting. STE/ICE-R can also perform as a multimeter and instruction on its use is in TM 9-4910-57-12&P

NOTE

While performing electrical troubleshooting, the black lead of multimeter must have metal to metal contact with ground point to receive accurate reading.

Malfunction/SymptomTroubleshooting Procedure**Engine**

- | | |
|--|------------|
| 1. Engine fails to crank when start switch is pressed..... | WP 0022 00 |
| 2. Engine cranks at normal speed but will not start after two attempts to start..... | WP 0022 00 |
| 3. Engine cranks at normal speed but will not start during extreme cold weather..... | WP 0022 00 |
| 4. Engine cranks slowly and will not start..... | WP 0022 00 |

Fuel, Air Intake, and Exhaust Systems

- | | |
|--|------------|
| 5. Engine starts running but fails to stay running..... | WP 0023 00 |
| 6. Engine fails to shut off when the engine fuel shutoff switch is activated..... | WP 0023 00 |
| 7. Engine fails to stop when fuel shutoff handle is pulled..... | WP 0023 00 |
| 8. Engine stalls at low rpm, does not develop full power, and has excessive smoke from one or both banks of cylinders..... | WP 0023 00 |
| 9. Engine stalls at low rpm and does not develop full power, but exhaust smoke is normal..... | WP 0023 00 |
| 10. Engine runs rough or misfires, knocks, and/or fuel consumption is excessive..... | WP 0023 00 |

Oil Cooling System

- | | |
|--|------------|
| 11. Low engine oil pressure, engine oil temperature normal..... | WP 0024 00 |
| 12. High engine oil pressure, engine oil temperature normal..... | WP 0024 00 |
| 13. Engine oil consumption excessive..... | WP 0024 00 |
| 14. High engine oil temperature..... | WP 0024 00 |

Ventilation Blower Assembly

- | | |
|--|------------|
| 15. Blower motor does not run..... | WP 0025 00 |
| 16. Blower runs but does not come up to speed..... | WP 0025 00 |
| 17. Blower unusually noisy..... | WP 0025 00 |

Transmission Center Section and Output Reduction Gears

- | | |
|--|------------|
| 18. High transmission oil temperature..... | WP 0026 00 |
| 19. Vehicle will steer or pivot but will not drive in any range..... | WP 0026 00 |
| 20. Vehicle will not drive in low range..... | WP 0026 00 |
| 21. Vehicle will not drive in intermediate range..... | WP 0026 00 |
| 22. Vehicle will not drive in high range..... | WP 0026 00 |
| 23. Vehicle will drive but creeps in neutral..... | WP 0026 00 |
| 24. Transmission cannot be down-shifted..... | WP 0026 00 |

Driver's Controls

- | | |
|--|------------|
| 25. Vehicle will not steer in either direction..... | WP 0027 00 |
| 26. Vehicle will steer in only one direction..... | WP 0027 00 |
| 27. Depressing brake pedal will not stop vehicle effectively..... | WP 0027 00 |
| 28. Brakes dragging at one or both sides of vehicle..... | WP 0027 00 |
| 29. Engine does not respond properly to throttle controls..... | WP 0027 00 |
| 30. No back pressure, or insufficient pressure, when operating purge pump..... | WP 0027 00 |
| 31. Excessive back pressure when operating purge pump..... | WP 0027 00 |

Tracks and Suspension

- | | |
|---|------------|
| 32. Vehicle pulls to one side..... | WP 0028 00 |
| 33. Vehicle throws track..... | WP 0028 00 |
| 34. Vehicle sags to one side..... | WP 0028 00 |
| 35. Vehicle rides excessively hard..... | WP 0028 00 |
| 36. Thumping noises heard during vehicle operation..... | WP 0028 00 |

Malfunction/Symptom

Troubleshooting Procedure

Tracks and Suspension—Continued

- 37. Excessive noise in track or suspension during vehicle operation..... WP 0028 00

Mechanical Transmission

- 38. Mechanical transmission fails to operate, slips, or chatters..... WP 0029 00

Main Winch

- 39. Main winch fails to operate..... WP 0030 00
- 40. Main winch operates with difficulty..... WP 0030 00
- 41. Main winch creeps with control in neutral or winch brake fails to hold load..... WP 0030 00
- 42. Main winch level winder fails to traverse..... WP 0030 00

Hoist Winch

- 43. Hoist winch fails to operate..... WP 0031 00
- 44. Hoist winch operates with difficulty..... WP 0031 00
- 45. Hoist winch creeps or fails to hold load..... WP 0031 00

Hoisting Boom

- 46. Hoisting boom does not operate..... WP 0032 00
- 47. Hoisting boom operates with difficulty..... WP 0032 00
- 48. Hoisting boom creeps..... WP 0032 00
- 49. Boom stayline cables become slack during live boom operation..... WP 0032 00

Spade

- 50. Spade fails to operate..... WP 0033 00
- 51. Spade operates with difficulty..... WP 0033 00
- 52. Spade creeps..... WP 0033 00

Main Hydraulic System

- 53. Insufficient or no main system oil pressure..... WP 0034 00
- 54. Loss of main hydraulic pressure during operation..... WP 0034 00

Auxiliary Hydraulic System

- 55. Insufficient or no auxiliary system oil pressure..... WP 0035 00
- 56. Loss of auxiliary hydraulic pressure during operation..... WP 0035 00
- 57. Main and hoist winches fail to operate..... WP 0035 00

APU

- 58. Engine fails to crank when starting switch is operated..... WP 0036 00
- 59. Engine cranks but fails to start..... WP 0036 00
- 60. Engine hard to start..... WP 0036 00
- 61. Engine hard to start in cold weather..... WP 0036 00
- 62. Engine starts but fails to keep running, misfires, or lacks power..... WP 0036 00
- 63. Engine overheating..... WP 0036 00
- 64. Engine discharges black smoke..... WP 0036 00
- 65. Engine knocks..... WP 0036 00
- 66. Engine uses excessive oil and discharges light blue smoky exhaust..... WP 0036 00

<u>Malfunction/Symptom</u>	<u>Troubleshooting Procedure</u>
Main Hydraulic Pump	
67. Main hydraulic pump fails to operate.....	WP 0037 00
68. Main hydraulic pump fails to develop sufficient pressure.....	WP 0037 00
69. Main hydraulic pump is noisy during operation.....	WP 0037 00
Auxiliary Hydraulic Pump	
70. Auxiliary hydraulic pump does not operate.....	WP 0038 00
Mechanical Transmission—Hydraulic	
71. Mechanical transmission fails to operate, slips, or chatters.....	WP 0039 00
Battery Power Circuit	
72. Battery-generator gage indicates low battery charge.....	WP 0041 00
Master Relay System and Slave Receptacle	
73. Master relay fails to operate.....	WP 0042 00
74. No power to slave receptacle.....	WP 0042 00
Engine Starting System	
75. Engine fails to crank.....	WP 0043 00
Engine Manifold Preheater System	
76. Manifold preheater fails to operate.....	WP 0044 00
Engine Fuel Shutoff Solenoid	
77. Engine cranks but fails to start.....	WP 0045 00
Fire Extinguisher Engine Shutoff Light	
78. Fire extinguisher engine shutoff light fails to operate while fuel shutoff switch operates normally.....	WP 0046 00
Electric In-Tank Fuel Pump	
79. Electric in-tank fuel pump fails to operate.....	WP 0047 00
Fuel Gage	
80. Fuel gage does not operate in either FRONT or REAR position.....	WP 0048 00
Engine Oil Temperature Gage	
81. Engine oil temperature gage does not operate.....	WP 0049 00
Engine Oil Pressure Gage	
82. Engine oil pressure gage does not operate.....	WP 0050 00
Power Control Lever Switch	
83. Engine exceeds 1800 rpm when hydraulic POWER lever is ON.....	WP 0051 00
Transmission Oil Temperature Gage	
84. Transmission oil temperature gage does not operate.....	WP 0052 00

Malfunction/Symptom

Troubleshooting Procedure

Transmission Oil Pressure Gage

- 85. Transmission oil pressure gage does not operate..... WP 0053 00

Engine Generator (Dual Voltage System)

- 86. Generator indicator reads in yellow or lower red region with engine running and generator cutout switch closed..... WP 0054 00
- 87. Generator cutout switch does not operate..... WP 0054 00

Engine Generator (Single Voltage System)

- 88. Generator indicator reads in yellow or lower red region with engine running and generator cutout switch closed..... WP 0055 00
- 89. Generator cutout switch does not operate..... WP 0055 00

APU Generator System (Dual Voltage)

- 90. Generator indicator reads in yellow or lower red region with APU engine running and APU generator switch on..... WP 0056 00

APU Generator System (Single Voltage)

- 91. Generator indicator reads in yellow or lower red region with APU engine running and APU generator switch on..... WP 0057 00

Generator Indicator Gage

- 92. Generator indicator gage fails to operate when MASTER switch is on..... WP 0058 00

APU Starting System

- 93. APU starter fails to crank or is hard to start in cold weather..... WP 0059 00

APU Fuel Solenoid System

- 94. APU fuel solenoid fails to operate..... WP 0060 00

APU Low Oil Pressure System

- 95. APU LOW OIL PRESS lamp fails to light when APU is not running..... WP 0061 00

APU High Air Temperature System

- 96. APU HIGH AIR TEMP lamp does not light when air temperature is high..... WP 0062 00

APU Engine Oil Pressure Gage Circuit

- 97. APU ENGINE OIL PRESSURE gage fails to operate..... WP 0063 00

Mechanical Transmission Oil Pressure Light

- 98. Mechanical transmission oil pressure warning light does not go out with mechanical transmission operating..... WP 0064 00
- 99. Mechanical transmission oil pressure warning light fails to operate with mechanical transmission stopped..... WP 0064 00

Master Warning Light

- 100. MASTER WARNING light fails to operate with engine off..... WP 0065 00
- 101. MASTER WARNING light does not go out after starting engine..... WP 0065 00
- 102. MASTER WARNING light does not light with high transmission oil temp, but lights with engine off..... WP 0065 00

Malfunction/Symptom

Troubleshooting Procedure

Master Warning Light-Continued

103. MASTER WARNING light does not light with high engine oil temp, but lights with engine off. WP 0065 00

Powerplant Warning Horn

104. Powerplant warning horn fails to operate. WP 0066 00

External Vehicle Warning Horn

105. External vehicle warning horn fails to operate. WP 0067 00

Bilge Pump System and Electrical Accessories Panel Power Outlet

106. Bilge pump fails to operate. WP 0068 00

107. Bilge pump indicator lamp fails to light and bilge pump operates. WP 0068 00

108. Electrical accessories panel power outlet has no power, and bilge pump operates. WP 0068 00

Personnel Heater Control System

109. Personnel heater fails to operate. WP 0069 00

Communication System

110. One radio fails to operate. WP 0070 00

Dome Lights

111. Both left front and left rear dome lights fail to operate. WP 0071 00

112. Both center and right front dome lights fail to operate. WP 0071 00

113. Only one dome light fails to operate. WP 0071 00

Passive Night Viewer

114. Passive night viewer lamp fails to light but passive night viewer operates. WP 0072 00

115. Passive night viewer fails to operate. WP 0072 00

116. Both lamp and passive night viewer fail to operate. WP 0072 00

Driver's Periscope

117. B.O. receiver lamp fails to light but driver's periscope operates. WP 0073 00

118. Driver's periscope fails to operate. WP 0073 00

119. Both lamp and driver's periscope fail to operate. WP 0073 00

Fixed Spotlight

120. Fixed spotlight fails to operate. WP 0074 00

Troublelight Assembly

121. Troublelight assembly fails to operate. WP 0075 00

Winch Light

122. Winch light fails to operate. WP 0076 00

Gage Panel Lights

123. One or all gage panel lamps fail to light. WP 0077 00

Malfunction/Symptom

Troubleshooting Procedure

Service Headlights

124. Service headlights fail to operate..... WP 0078 00

High Beam Indicator

125. High beam indicator fails to light with high beams on, in Infrared (IR) or SER DRIVE condition..... WP 0079 00

Service Stoplight

126. Service stoplight fails to operate..... WP 0080 00

B.O. Service Condition (IR Headlights)

127. IR headlights fail to operate..... WP 0081 00

B.O. Service Condition (B.O. Stoplight)

128. B.O. stoplight fails to operate in any B.O. mode..... WP 0082 00

B.O. Marker Condition

129. Front B.O. marker fails to operate..... WP 0083 00

130. Rear B.O. marker fails to operate..... WP 0083 00

B.O. Drive Condition

131. B.O. drive lights fail to operate..... WP 0084 00

Rigger's Lights and Front Signal Light

132. One or both rigger's service lamps fail to operate..... WP 0085 00

133. Front signal light and/or indicator light fails to operate, but indicator lamp operates..... WP 0085 00

Ventilation Blower System

134. Ventilation blower fails to operate..... WP 0086 00

Engine Generator Blower Motor

135. Engine generator blower motor fails to operate when engine is running..... WP 0087 00

M8A3 Filter Unit System

136. M2A2 air purifier fails to operate..... WP 0088 00

M239 Smoke Grenade Launcher System

137. One or more of the launcher tubes fails to operate..... WP 0089 00

Hydraulic Reservoir Monitoring System Switches and Lights

138. Hydraulic oil high temperature lamp fails to operate when temperature limit is exceeded..... WP 0090 00

139. Hydraulic oil high temperature light fails to go out when temperature is normal..... WP 0090 00

Hydraulic Reservoir Monitoring System Gage and Transmitter

140. Hydraulic oil temperature gage fails to operate..... WP 0091 00

Malfunction/Symptom

Troubleshooting Procedure

Exhaust Smoke Generating System

- 141. Vehicle generates smoke but indicator light fails to operate..... WP 0092 00
- 142. Vehicle does not generate smoke..... WP 0092 00
- 143. Commander's switch fails to operate..... WP 0092 00

Fuel/Water Separator Control Module System

- 144. Automatic water drain system fails to operate..... WP 0093 00

END OF WORK PACKAGE

UNIT MAINTENANCE
RECOVERY VEHICLE, FULL TRACKED: MEDIUM, M88A1
NSN 2350-00-122-6826, EIC AQA
ENGINE TROUBLESHOOTING PROCEDURE

INITIAL SETUP:**Tools and Special Tools**

Tool kit, general mechanic's (item 59, WP 0490 00)

Materials/Parts

Compound, cleaning (item 9, WP 0489 00)

References

WP 0041 00
 WP 0043 00
 WP 0044 00
 WP 0045 00
 WP 0047 00
 WP 0096 00
 WP 0118 00
 WP 0122 00

References (cont.)

WP 0124 00
 WP 0126 00
 WP 0127 00
 WP 0128 00
 WP 0131 00
 WP 0134 00
 WP 0136 00
 WP 0152 00
 WP 0153 00
 WP 0336 00
 WP 0362 00
 WP 0402 00
 TM 9-2350-256-10

Troubleshooting Procedure**Engine****Symptom**

Engine malfunctioning.

Malfunction

Engine fails to crank when starter switch is pressed. Do steps 1 and 2.

Engine cranks at normal speed but will not start after two attempts to start. Do steps 3 thru 10.

Engine cranks at normal speed but will not start during extreme cold weather. Do steps 11 thru 15.

Engine cranks slowly and will not start. Do steps 16 thru 19.

CORRECTIVE ACTION

1. Turn MASTER switch on and test batteries in accordance with serviceability test in PMCS (see WP 0096 00).
2. While moving transmission shift lever into park position, observe neutral safety switch activating lever. If lever fails to move, check linkage connecting transmission shift assembly to neutral safety switch lever cross shaft (see WP 0362 00). Reconnect linkage if disconnected. If linkage is bent, straighten or replace damaged parts. If lever does not depress neutral safety switch, make adjustments (see WP 0362 00).
3. Check fire extinguisher engine shutoff switch for proper adjustment (see WP 0402 00). Ensure fire extinguisher engine shutoff activated lamp is lit.
4. Turn MASTER switch on. Turn FUEL SHUTOFF switch ON. Listen for a click from engine. If no click can be heard, troubleshoot fuel shutoff solenoid circuit (see WP 0045 00).

CORRECTIVE ACTION –Continued

5. Place manual fuel shutoff handle in ON (in) position. Remove cotter pin. Place engine fuel shutoff lever in ON (up) position. Check connector link for a free pin fit. If a free pin fit cannot be made, make adjustments in accordance with WP 0124 00.
6. Turn MASTER switch and in-tank fuel pump switch ON. The electric fuel pump will make noise. If there is no noise, troubleshoot fuel shutoff solenoid circuit (see WP 0045 00). If there is a noise, perform the following fuel flow test. Disconnect fuel tank supply hose at engine primary fuel filter. Remove quick disconnect. Place a 5-gallon (19-liter [L]) container in a suitable position to collect fuel from hose. Turn MASTER and in-tank fuel pump switches to ON position. Time fuel flow into container. If there is no fuel flow or fuel flow is less than 3 gallons per minute (gpm) (11 liters per minute [Lpm]), inspect fuel lines for restrictions. If there are no restrictions, troubleshoot electric fuel pump (see WP 0047 00).
7. Disconnect fuel line connecting primary fuel filter and main fuel check valve at main fuel check valve (check valve fuel inlet hose). Place fuel line in a suitable container. Place MASTER and fuel pump switches in ON position. If there is no fuel flow, replace primary fuel filter element (see WP 0127 00).

NOTE

If the cause of filter restriction is excessive algae contamination, notify Direct Support Maintenance to clean and drain fuel tanks and fill with uncontaminated fuel.

8. Disconnect fuel line connecting mechanical fuel pump assembly and fuel/water separator at fuel/water separator. Position a container to catch fuel. With MASTER and fuel pump switches in ON position, crank engine. If there is no fuel flow from disconnected fuel line, replace mechanical (gear type) fuel pump assembly (see WP 0118 00). If there is fuel flow, reconnect fuel line and go to step 9.
9. Loosen air bleeder valve on top of fuel/water separator. With MASTER and fuel pump switches in ON position, crank engine. If there is no fuel flow from air bleeder valve, replace outer fuel/water separator elements (see WP 0128 00). If there is fuel flow, go to step 12.
10. Disconnect fuel line connecting fuel/water separator and engine at elbow on left front engine shroud. Position suitable container to catch fuel from fuel line. With MASTER and fuel pump switches in ON position, crank engine. If no fuel flows from line, replace final filter in fuel/water separator element (see WP 0128 00). If engine fails to start, notify Direct Support Maintenance.
11. Check fire extinguisher engine shutoff switch for proper adjustment (see WP 0402 00 for removing manual interlock systems). Verify that fire extinguisher engine shutoff activated light is lit.
12. Place transmission shift lever in neutral position. Open rear grille doors and position yourself by exhaust pipe outlet. Have assistant place MASTER switch in on position and press manifold heater switch. If electrical portion of manifold heater is working, a sparking sound will be heard at each exhaust pipe outlet. If no sound is heard, troubleshoot engine starter circuit (see WP 0043 00).
13. Turn MASTER and fuel pump switches to ON position. Operate purge pump. If little or no resistance is felt or excessive force is required during operation or purge pump cannot be operated, perform the following procedures. Turn MASTER switch to OFF position. Remove fuel line connected to in port on purge pump. Place fuel line in a suitable container and turn MASTER switch to on position. If no fuel flows from line, perform fuel flow test (see step 6). If fuel flows into the container, place MASTER switch in OFF position and connect fuel line. Disconnect fuel line from out side of purge pump. Place a suitable container under purge pump. Place MASTER switch in on position and operate purge pump. If fuel flows from out port, connect fuel line. If no fuel flows from purge pump or handle still will not move, repair/replace purge pump (see WP 0122 00). Disconnect fuel filler inlet tube between main fuel check valve and manifold fuel filter. Turn MASTER and fuel pump switches to ON position. Press starter button and operate purge pump. If handle was excessively hard to operate or could not be operated previously and can now be operated, replace main fuel check valve (see WP 0126 00). Disconnect left intake manifold tube at tee on manifold heater fuel inlet solenoid valve. With MASTER

CORRECTIVE ACTION –Continued

and fuel pump switches in ON position, press preheat and starter buttons while operating purge pump. If no fuel flows from tee, install new manifold preheater fuel filter (see WP 0131 00).

14. Operate pump with MASTER and fuel pump in ON position. Press preheat and starter buttons. If fuel fails to flow, troubleshoot manifold preheater circuit (see WP 0044 00).
15. Remove engine deck (see WP 0336 00) and both plastic tubes at manifold heater nozzles. With an assistant to watch both tube ends, turn MASTER and fuel pump switches to ON position. Press starter and preheater buttons while operating purge pump. If no fuel flows from one or both tubes, replace defective tubes (see WP 0136 00). If fuel flows from both tubes, disconnect manifold heater return tube (see WP 0136 00). Inspect manifold heater for damaged threads or plugged orifice. Replace manifold heater if threads are damaged (see WP 0134 00).

WARNING

Solvents can burn easily, give off harmful vapors, and are harmful to skin and clothing. To avoid injury or death, keep away from open flame and use in a well-ventilated area. If solvent gets on skin or clothing, wash immediately with soap and water.

If orifice is plugged, soak nozzle with cleaning compound (item 9, WP 0489 00). Using a fine wire, clean orifice opening. Inspect filters for contamination or damage. Clean or replace filters (see WP 0131 00). Assemble in reverse order of disassembly. Install manifold heater nozzle assembly and tighten jamnut. Connect manifold heater fuel inlet hose and fuel return tube.

16. Perform battery serviceability test (see WP 0041 00). Recharge or replace low batteries (see WP 0153 00).
17. If during battery test battery voltage was below 12 volts and starter still tried to turn over engine, starter protection module may be defective, troubleshoot engine starter circuit (see WP 0043 00). Replace starter module if defective (see WP 0152 00).
18. Check engine for proper grade of oil. If wrong grade of oil for prevailing temperature is in engine do the following: Use external means to heat engine compartment. After engine starts, run it until engine reaches operating temperature. Drain engine and/or transmission and fill with proper grade of oil for prevailing temperatures as specified in TM 9-2350-256-10.
19. While assistant engages starter, listen at vehicle right rear cooling air inlet grilles for a spinning noise. If spinning noise is present, replace starter assembly (see WP 0152 00).

END OF WORK PACKAGE

UNIT MAINTENANCE
RECOVERY VEHICLE, FULL TRACKED: MEDIUM, M88A1
NSN 2350-00-122-6826, EIC AQA

FUEL, AIR INTAKE, AND EXHAUST SYSTEMS TROUBLESHOOTING PROCEDURE

INITIAL SETUP:

Tools and Special Tools

Tool kit, general mechanic's (item 59, WP 0490 00)

Personnel Required

Mechanics (2)

References

WP 0045 00
 WP 0047 00
 WP 0116 00
 WP 0118 00

References (cont.)

WP 0119 00
 WP 0124 00
 WP 0127 00
 WP 0128 00
 WP 0130 00
 WP 0144 00
 WP 0336 00
 WP 0342 00
 WP 0364 00

Troubleshooting Procedure

Fuel, Air Intake, and Exhaust Systems

Symptom

Fuel, air intake, or exhaust systems malfunctioning.

Malfunction

Engine starts running, but fails to stay running. Do steps 1 thru 5.

Engine fails to shut off when engine fuel shutoff switch is activated. Do step 6.

Engine fails to stop when fuel shutoff handle is pulled. Do step 7.

Engine stalls at low rpm, does not develop full power, and has excessive smoke from one or both banks of cylinders. Do steps 8 and 9.

Engine stalls at low rpm, does not develop full power, but exhaust smoke is normal. Do steps 10 thru 13.

Engine runs rough or misfires, knocks, and/or fuel consumption is excessive. Do step 14.

CORRECTIVE ACTION

1. With MASTER switch and in-tank fuel pump switch in ON position, electric fuel pump will make a noise. If there is no noise, troubleshoot electric fuel pump circuit (see WP 0047 00). If there is noise go to step 12 and perform fuel flow test.
2. Disconnect fuel line connecting primary fuel filter and main fuel check valve at main fuel check valve. Place fuel line in a suitable container. Place MASTER and fuel pump switches in the ON position. If there is no fuel flow, clean filter and/or replace the primary fuel filter element (see WP 0127 00).

NOTE

If cause of filter restriction is excessive algae contamination, notify Direct Support Maintenance to drain and clean fuel tanks and fill with uncontaminated fuel.

CORRECTIVE ACTION –Continued

3. Disconnect fuel line connecting mechanical fuel pump assembly and fuel/water separator. Position container to catch fuel. With MASTER and fuel pump switches in ON position, crank the engine. If there is no fuel flow from the disconnected fuel line, replace mechanical (gear type) fuel pump assembly (see WP 0118 00). If there is no fuel flow, reconnect fuel line and go to step 4.

CAUTION

Do not remove or disturb the center (final) filter element. If the center (final) filter element is removed, the element must be replaced.

4. Loosen air bleeder valve on top of fuel/water separator. With MASTER and fuel pump switches in ON position, crank the engine. If there is no fuel flow from air bleeder valve, replace outer fuel/water separator elements (see WP 0128 00).
5. Disconnect fuel line connecting fuel/water separator and engine at elbow on left front engine shroud. Position a suitable container to catch fuel from fuel line. With MASTER and fuel pump switches in ON position, crank the engine. If no fuel flows from line, replace final filter in fuel/water separator (see WP 0128 00). If problem is not corrected after above checks, notify Direct Support Maintenance.

NOTE

If engine does not shutoff using fuel shutoff switch, use manual fuel shutoff handle to stop engine.

6. With MASTER switch in ON position, have an assistant operate FUEL SHUTOFF switch several times. Listen for a click from engine. If no click can be heard, troubleshoot fuel shutoff solenoid (see WP 0045 00). If click can be heard, notify Direct Support Maintenance.
7. Remove left- and center-front air inlet grilles (see WP 0342 00). Have an assistant move manual fuel shutoff handle in and out. If manual fuel shutoff linkage on front of engine does not move, replace fuel shutoff control cable assembly (see WP 0124 00). If manual fuel shutoff linkage on front of engine moves, do the following: Remove engine deck (see WP 0336 00). Remove forward engine cooling fan (see WP 0144 00). While assistant moves manual fuel shutoff handle in and out, observe manual fuel shutoff lever on side of fuel injector pump for movement. If manual fuel shutoff lever does not move, replace manual fuel shutoff lever (see WP 0124 00).
8. Open exhaust deflector doors and inside deck doors. Check exhaust outlets and exhaust pipes for damage and restrictions. Remove any restrictions. Repair or replace damaged parts.
9. Inspect air intake hoses and tubes for damage and restrictions. Remove any restrictions. Repair or replace damaged parts.
10. Remove left- and center-front air inlet grilles (see WP 0342 00). Have an assistant move accelerator pedal to full throttle position. Observe throttle linkage on front of engine. If throttle linkage does not have full travel, adjust throttle linkage (see WP 0364 00).
11. Check fuel return line (see WP 0119 00) on front of engine for proper connection.
12. With MASTER switch and in-tank fuel pump switch in ON position, electric fuel pump will make a noise. If there is no noise, troubleshoot electric fuel pump circuit (see WP 0047 00). If there is a noise, perform the following fuel flow test. Disconnect fuel tank supply hose at engine primary fuel filter. Remove quick-disconnect. Place a 5-gallon (19-liter) container in a suitable position to collect fuel from hose. Turn MASTER and in-tank fuel pump switch to ON position. Time fuel flow into container. If there is no fuel flow or fuel flow is less than 3 gallons per minute (11 liters per minute), inspect fuel lines for restriction. If there is no fuel line restriction, replace electric fuel pump (see WP 0116 00).
13. Remove fuel/water separator filter bleeder valve. Install a pressure gage (minimum of 100 psi [690 kPa]) in fuel/water separator filter cover bleeder valve opening. Turn MASTER and in-tank fuel pump switches to ON position. Start engine and operate at high idle speed (1800–2400 rpm). Pressure should

CORRECTIVE ACTION –Continued

read 55–60 psi (379–413 kPa). If fuel pressure is less than 55 psi (379 kPa), clean filter and replace primary fuel filter element (see WP 0127 00).

Turn MASTER and in-tank fuel pump switches to ON position. Start engine and operate at high idle speed (1800–2400 rpm). Pressure should read 55–60 psi (379–413 kPa). If fuel pressure is less than 55 psi (379 kPa), replace mechanical (gear type) fuel pump (see WP 0118 00).

If fuel pressure is less than 55 psi (379 kPa), replace all three fuel/water separator elements (see WP 0128 00).

14. With engine not running, open rear exhaust doors and observe engine deck liner for wet spots. If wet spots can be seen on engine deck liner, remove engine deck (see WP 0336 00). Remove front and rear cooling fan (see WP 0144 00). Loosen and tighten fuel line fittings that show evidence of leaking. If leakage persists, notify Direct Support Maintenance. If no wet spots are found on engine deck liner, remove left- and center-front air inlet grilles (see WP 0342 00) and check for fuel leaks. Tighten, repair, or replace fuel lines or components leaking fuel. Check for proper operation of fuel/water separator automatic drain system (see WP 0130 00). If leaking and/or excessive fuel consumption persists, notify Direct Support Maintenance.

END OF WORK PACKAGE

UNIT MAINTENANCE
RECOVERY VEHICLE, FULL TRACKED: MEDIUM, M88A1
NSN 2350-00-122-6826, EIC AQA
OIL COOLING SYSTEM TROUBLESHOOTING PROCEDURE

INITIAL SETUP:**Tools and Special Tools**

Tool kit, general mechanic's (item 59, WP 0490 00)
 Cleaner, oil cooler (item 138, WP 0488 00)
 Gage, pressure (item 156, WP 0488 00)

Personnel Required

Mechanics (2)

References

WP 0050 00
 WP 0104 00

References (cont.)

WP 0108 00
 WP 0148 00
 WP 0149 00
 WP 0171 00
 WP 0342 00
 WP 0345 00
 TM 9-2350-256-10

Troubleshooting Procedure**Oil Cooling System****Symptom**

Oil cooling system malfunctioning.

Malfunction

Low engine oil pressure, engine oil temperature normal. Do steps 1 thru 4.

High engine oil pressure, engine oil temperature normal. Do steps 1 thru 5.

Engine oil consumption excessive. Do step 6.

High engine oil temperature. Do steps 7 thru 11.

CORRECTIVE ACTION

1. Check to see that proper grade of oil for prevailing temperature is used in engine. If improper grade was used, refill with proper grade of oil (refer to TM 9-2350-256-10).
2. Check main engine crank case for proper oil level. Refer to TM 9-2350-256-10 instructions on checking engine oil level. Check that oil is not diluted. Drain and refill if oil is diluted (refer to TM 9-2350-256-10).
3. Remove left- and center-front air inlet grilles (see WP 0342 00) and open side air inlet grille doors. Inspect oil lines for evidence of leaking. Tighten or replace any lines or connections that are leaking. Check oil drain valve plug (see WP 0104 00). If valve plug is loose, tighten and recheck oil pressure. If oil pressure is low, do to step 4. If oil pressure is high, go to step 5.

CAUTION

Be sure to use the proper pressure gage for the pressure range to be tested.

4. Remove left- and center-front air inlet grilles (see WP 0342 00) if they have not already been removed. Remove main engine oil pressure switch (see WP 0171 00) and install pressure gage (item 156, WP 0488 00). If pressure gage reads 40–70 psi (276–483 kPa) at 2400 rpm and engine oil pressure gage

CORRECTIVE ACTION –Continued

- reads lower, troubleshoot engine oil pressure gage circuit (see WP 0050 00). If pressure gage reads less than 40 psi (276 kPa) at 2400 rpm, notify Direct Support Maintenance.
5. Remove left- and center-front air inlet grilles (see WP 0342 00). Remove main engine oil pressure switch (see WP 0171 00) and install pressure gage (item 156, WP 0488 00). If pressure gage reads 40–70 psi (276–483 kPa) at 2400 rpm and engine oil pressure gage reads higher, troubleshoot engine oil pressure gage circuit (see WP 0050 00). If pressure gage reads higher than 70 psi (483 kPa) at 2400 rpm, notify Direct Support Maintenance.
 6. While an assistant operates vehicle, look at engine exhaust. If there is excessive smoke from one or both banks of cylinders or exhaust is oily, remove crankcase breather tube (see WP 0108 00). Check to see if engine breather tube is clogged. Service or replace clogged breather tube. If there is no evidence of excessive exhaust smoke and exhaust is not oily, remove left- and center-front air inlet grilles (see WP 0342 00) and open side air inlet grille doors. Check engine externally for evidence of oil leaks. Tighten all loose fittings and connections.
 7. Check engine cooling grille openings for restrictions. Remove all material that blocks air flow to engine.
 8. Remove left and right deck air inlet doors (see WP 0345 00). Check engine oil cooler screens for restrictions (see WP 0148 00). Remove all restrictions from oil cooler screens.
 9. Visually inspect engine oil cooler air passages. If engine oil cooler air passages are restricted, clean passages using oil cooler cleaning tool (item 138, WP 0488 00).
 10. Remove left- and center-front air inlet grilles (see WP 0342 00) and inspect oil cooler lines for kinks and/or twists. Repair or replace any damaged oil cooler lines (see WP 0149 00).

WARNING

Care should be taken when feeling tubes. They can be hot enough to burn.

11. With engine operating at approximately 200°F (93°C), cautiously feel oil cooler lines and oil cooler. If oil cooler lines are hot and oil cooler is only warm, notify Direct Support Maintenance.

END OF WORK PACKAGE

UNIT MAINTENANCE
RECOVERY VEHICLE, FULL TRACKED: MEDIUM, M88A1
NSN 2350-00-122-6826, EIC AQA
VENTILATION BLOWER ASSEMBLY TROUBLESHOOTING PROCEDURE

INITIAL SETUP:**Tools and Special Tools**

Tool kit, general mechanic's (item 59, WP 0490 00)

References

WP 0041 00
 WP 0054 00
 WP 0055 00

References (cont.)

WP 0056 00
 WP 0057 00
 WP 0086 00
 WP 0153 00
 WP 0250 00

Troubleshooting Procedure**Ventilation Blower Assembly****Symptom**

Ventilation blower malfunctioning.

Malfunction

Blower motor does not run. Do step 1.

Blower runs but does not come up to speed. Do steps 2 thru 4.

Blower unusually noisy. Do steps 5 and 6.

CORRECTIVE ACTION

1. Check for defective blower switch and/or circuit breaker. Troubleshoot vehicle blower circuit (see WP 0086 00).

WARNING

Do not operate or perform maintenance on hydraulic system while doing maintenance work in the vicinity of the boom actuating cylinder.

2. Check for obstructed air passage. To access intake opening, hoist boom and remove rubber covering of the boom, actuating cylinder and hoisting boom connection inside the vehicle. Remove any obstructions. If blower still does not come up to speed, go to step 3.
3. Check for low input due to low voltage batteries while engine is not running. Perform battery serviceability test (see WP 0041 00). Recharge or replace low voltage batteries (see WP 0153 00). If blower still does not come up to speed, go to step 4.

CORRECTIVE ACTION –Continued

4. Check generator for proper output while engine is running. Troubleshoot APU generator output circuit (see WP 0056 00 for dual voltage; 0057 00 for single voltage) and generator output circuit (see WP 0054 00 for dual voltage; 0055 00 for single voltage).
5. Check for defective blower assembly. Troubleshoot ventilating blower circuit (see WP 0086 00).
6. Check for loose blower assembly. Tighten mounting screw (see WP 0250 00).

END OF WORK PACKAGE

UNIT MAINTENANCE
RECOVERY VEHICLE, FULL TRACKED: MEDIUM, M88A1
NSN 2350-00-122-6826, EIC AQA
TRANSMISSION CENTER SECTION AND OUTPUT REDUCTION GEARS
TROUBLESHOOTING PROCEDURE

INITIAL SETUP:**Tools and Special Tools**

Tool kit, general mechanic's (item 59, WP 0490 00)
Cleaner, oil cooler (item 138, WP 0488 00)

References

WP 0361 00
WP 0362 00
TM 9-2350-256-10

Personnel Required

Mechanics (2)

Troubleshooting Procedure**Transmission Center Section and Output Reduction Gears****Symptom**

Transmission center section or output reduction gears malfunctioning.

Malfunction

High transmission oil temperature. Do steps 1 thru 5.

Vehicle will steer or pivot but will not drive in any range. Do step 6.

Vehicle will not drive in low range. Do step 6.

Vehicle will not drive in intermediate range. Do step 6.

Vehicle will not drive in high range. Do step 6.

Vehicle will drive but creeps in neutral. Do step 6.

Transmission cannot be down-shifted. Do step 7.

CORRECTIVE ACTION

1. Check transmission for proper oil level. Add oil if low or drain to proper level if over full (refer to TM 9-2350-256-10).
2. Open side air inlet doors. Check transmission oil cooler screens for restrictions. Remove all restrictions from oil cooler screens.
3. Visually inspect transmission oil cooler air passages. If transmission oil cooler air passages are restricted, clean air passages using oil cooler cleaning tool (item 138, WP 0488 00).

CORRECTIVE ACTION –Continued

4. Inspect four transmission oil cooler tubes for damage/leaks. Replace damaged tubes.

WARNING

Care should be taken when feeling tubes. They can be hot enough to burn.

5. With engine operating at approximately 200°F (93°C), cautiously feel oil cooler lines and oil cooler. If oil cooler tubes are hot and oil cooler is only warm, notify Direct Support Maintenance. Turn off engine.
6. Open left rear exhaust deflector grille door and inside deck doors. While an assistant moves shifting control lever through each position, observe transmission shift lever for movement. If transmission shift lever does not move, check linkages and repair or replace broken or missing parts (see WP 0361 00). Check the shift linkages adjustments (see WP 0362 00). If transmission shift lever still cannot be moved, notify Direct Support Maintenance
7. Open left rear exhaust deflector grille door and inside deck doors. Remove screw, securing rear shifting rod to transmission shift lever. While an assistant moves transmission shift control through each range position, observe rear shifting rod for movement. If rear shifting rod does not move, check linkage and repair or replace broken or missing parts (see WP 0361 00). Check the shift linkages adjustments (see WP 0362 00). If transmission shift lever on transmission cannot be moved, notify Direct Support Maintenance.

END OF WORK PACKAGE

UNIT MAINTENANCE
RECOVERY VEHICLE, FULL TRACKED: MEDIUM, M88A1
NSN 2350-00-122-6826, EIC AQA
DRIVER'S CONTROLS TROUBLESHOOTING PROCEDURE

INITIAL SETUP:**Tools and Special Tools**

Tool kit, general mechanic's (item 59, WP 0490 00)

Personnel Required

Mechanics (2)

References

WP 0047 00

WP 0098 00

WP 0122 00

WP 0123 00

References (cont.)

WP 0126 00

WP 0127 00

WP 0265 00

WP 0342 00

WP 0358 00

WP 0363 00

WP 0365 00

WP 0483 00

TM 9-2350-256-10

Troubleshooting Procedure**Driver's Controls****Symptom**

Driver's controls malfunctioning.

Malfunction

Vehicle will not steer in either direction. Do step 1.

Vehicle will steer in only one direction. Do step 1.

Depressing brake pedal will not stop vehicle effectively. Do step 2.

Brakes dragging at one or both sides of vehicle. Do steps 3 and 4.

Engine does not respond properly to throttle controls. Do step 5.

No back pressure, or insufficient pressure, when operating purge pump. Do steps 6 thru 9.

Excessive back pressure when operating purge pump. Do steps 10 thru 13.

CORRECTIVE ACTION**NOTE**

Check vehicle maintenance record for proper lubrication of steering, brake, and throttle linkages. If proper lubrication maintenance has been performed (refer to TM 9-2350-256-10), perform the following procedures.

1. Open left rear exhaust deflector door and transmission access door. While an assistant moves steering wheel from full-right to full-left turn, observe movement of transmission steer lever on steer valve body of transmission. If transmission steer arm does not move, check linkage and repair/replace broken or missing parts. If transmission steer linkage does not move, check steer linkage adjustment (see WP

CORRECTIVE ACTION –Continued

- 0358 00). If all mechanical linkages are properly adjusted and move freely, notify Direct Support Maintenance.
2. Open rear exhaust deflector grille doors and transmission access doors. Observe brake adjustment gage and alignment mark on brake rod (see WP 0365 00). If brake adjustment gage and alignment mark on brake rod do not line up, adjust brake. Check adjustment on brake air valve linkage (see WP 0265 00) and adjust if required.
 3. Open rear exhaust deflector doors and transmission access doors. With brakes released, check to see that each brake-supply-and-slack-adjustment lever (right and left) is touching the respective stops. If brake-supply-and-slack-adjustment levers do not touch their respective stops, adjust brake linkage (see WP 0365 00).
 4. With brakes properly adjusted, have assistant apply and release brakes several times. Observe each time that both right and left brake-supply-and-slack-adjustment levers return to their respective stops. If brakes do not fully release each time, check linkages and repair or replace any binding, bent, or broken parts.
 5. Remove left- and center-front air inlet grilles (see WP 0342 00). Disconnect one end of the throttle rod (see WP 0363 00). Have an assistant depress accelerator pedal to its maximum. Depress accelerator linkage on front of engine to its maximum. If a free pin cannot be made, check linkage and repair or replace any binding, bent, or broken parts. Check throttle linkage adjustment (see WP 0363 00). If a free pin fit can be made, notify Direct Support Maintenance.
 6. Check purge pump fuel lines between purge pump and main engine for leaks.
 7. Turn MASTER switch to OFF position. Remove fuel line connected to in port on purge pump. Place fuel line in a container and turn MASTER switch to on position. If no fuel flows from disconnected fuel lines, troubleshoot electric fuel pump (see WP 0047 00).
 8. If fuel flows into container, turn MASTER switch to OFF position and connect fuel line. Disconnect fuel line from out side of purge pump. Place a container under purge pump, turn MASTER switch to on position and operate purge pump. If no fuel flows from purge pump, turn MASTER switch to OFF position. Replace purge pump (see WP 0122 00).
 9. Remove front air inlet grilles (see WP 0342 00). Unscrew fuel outlet hose at main engine fuel check valve (see WP 0126 00). Disconnect main engine fuel hose at primary fuel filter (see WP 0127 00). Operate purge pump with MASTER and fuel pump switches in ON position. If no back pressure or only light back pressure can be felt during operation, replace main engine fuel check valve (see WP 0126 00).
 10. Remove front air inlet grilles (see WP 0342 00). Check primer hose and fuel return hose for proper connection at quick-disconnects (see WP 0098 00).
 11. Check purge pump fuel lines between purge pump and main engine for kinks or restrictions. Replace or repair kinks or restricted fuel lines (see WP 0123 00).

CORRECTIVE ACTION –Continued

12. Disconnect fuel line from OUT side of fuel pump. Place a container under purge pump. Turn MASTER switch to on position and operate purge pump. If purge pump cannot be operated or excessive pressure is required to operate purge pump, replace purge pump (see WP 0122 00).

WARNING

To prevent injury to personnel or damage to equipment, chock vehicle (see WP 0483 00).

13. Place transmission shift lever in neutral position. Turn MASTER switch and fuel pump switches to ON position, press starter button and preheat button located on purge pump handle. If purge pump operates with no excessive pressure, replace main engine fuel check valve (see WP 0126 00).

END OF WORK PACKAGE

UNIT MAINTENANCE
RECOVERY VEHICLE, FULL TRACKED: MEDIUM, M88A1
NSN 2350-00-122-6826, EIC AQA
TRACKS AND SUSPENSION TROUBLESHOOTING PROCEDURE

INITIAL SETUP:**Tools and Special Tools**

Tool kit, general mechanic's (item 59, WP 0490 00)

Personnel Required

Mechanics (2)

References

WP 0265 00

WP 0274 00

References (cont.)

WP 0275 00

WP 0277 00

WP 0279 00

WP 0280 00

WP 0285 00

TM 9-2350-200-24

TM 9-2350-256-10

Troubleshooting Procedure**Tracks and Suspension****Symptom**

Tracks or suspension malfunctioning.

Malfunction

Vehicle pulls to one side. (This condition is normal on a crowned road. The vehicle will pull to the low side of the road.) Do steps 2 thru 5.

Vehicle throws track. Do 1 thru 3.

Vehicle sags to one side. Do steps 2, 3, and 5.

Vehicle rides excessively hard. Do steps 5 and 7.

Thumping noises heard during vehicle operation. Do steps 8 and 9.

Excessive noise in track or suspension during vehicle operation. Do steps 1 thru 3, and 6.

CORRECTIVE ACTION

1. Inspect tracks for foreign material lodged in track or between roadwheels and support rollers. Remove foreign material from tracks, roadwheels, and support rollers.
2. Inspect tracks for damaged end connectors and center guides. Inspect track shoes for separation of rubber from metal tubes, inspect track for dead track shoes and for shoes with chunked rubber or rubber worn down to metal tubes. Replace worn, missing, or damaged parts (refer to TM 9-2350-256-10).
3. Check track tension and adjust if necessary (refer to TM 9-2350-256-10).
4. Open grille doors. Have assistant apply brakes. Check that black mark on brake rod is in alignment with brake adjustment gage. Adjust brakes if required (see WP 0265 00).

CORRECTIVE ACTION –Continued

5. Attempt to lift each roadwheel of vehicle with a crowbar. If wheel can be lifted, torsion bar is broken. Replace broken torsion bar (see WP 0275 00).

WARNING

Care should be taken when feeling wheel hubs, they can be hot enough to burn.

6. Immediately after vehicle operation, feel all roadwheel hubs for noticeable temperature difference. An overheated hub indicates an unadjusted, inadequately lubricated, or damaged bearing. Replace defective roadwheel bearings (see WP 0277 00).

WARNING

Care should be taken when feeling shocks, they can be hot enough to burn.

7. Immediately after vehicle operation, feel all shock absorbers. If heat is not felt, shock absorber is malfunctioning. Replace shock absorber (see WP 0285 00).
8. Inspect track shoes for serviceability (refer to TM 9-2350-200-24). Replace unserviceable track shoes (refer to TM 9-2350-256-10).
9. Inspect roadwheel and track support rollers for serviceability (refer to TM 9-2350-200-24). Replace unserviceable roadwheels (see WP 0274 00) and support rollers (see WP 0279 00 and 0280 00).

END OF WORK PACKAGE

UNIT MAINTENANCE
RECOVERY VEHICLE, FULL TRACKED: MEDIUM, M88A1
NSN 2350-00-122-6826, EIC AQA
MECHANICAL TRANSMISSION TROUBLESHOOTING PROCEDURE

INITIAL SETUP:**Tools and Special Tools**

Tool kit, general mechanic's (item 59, WP 0490 00)
 Gage, pressure (item 156, WP 0488 00)
 STE/ICE-R kit (item 163, WP 0488 00)

References

WP 0098 00
 WP 0297 00
 WP 0342 00
 WP 0417 00

Troubleshooting Procedure**Mechanical Transmission****Symptom**

Mechanical transmission malfunctioning.

Malfunction

Mechanical transmission fails to operate, slips, or chatters. Do steps 1 thru 4.

CORRECTIVE ACTION

1. Remove front air inlet grilles (see WP 0342 00). Inspect power takeoff coupling to see that drive shaft is firmly attached to power takeoff coupling. Tighten bolts and/or replace missing bolts and lockwashers.
2. Have assistant start engine. Observe power takeoff coupling and drive shaft. If the power takeoff coupling and drive shaft are not turning, turn off engine and remove powerplant (see WP 0098 00). Tighten power takeoff retaining nut. Torque nut to 240–250 lb-ft (325–339 N•m). Reinstall powerplant (see WP 0098 00).
3. Remove rear center subfloor plate (see WP 0297 00). Remove pipe plug in mechanical transmission and perform STE/ICE-R test 50 (pressure gage optional) (items 156 and 163, WP 0488 00). Lubricating oil pressure should be 10–19 psi (69–131 kPa). If lubricating oil pressure is not 10–19 psi (69–131 kPa), notify Direct Support Maintenance.
4. Disconnect hydraulic line (see WP 0417 00). Install tee and perform STE/ICE-R test 50 (pressure gage optional) (items 156 and 163, WP 0488 00). Connect hydraulic line. Operate engine at 1600 rpm. Mechanical transmission clutch operating pressure should be 140–225 psi (965–1551 kPa). If clutch pressure is not 140–225 psi (965–1551 kPa), notify Direct Support Maintenance.

END OF WORK PACKAGE

UNIT MAINTENANCE
RECOVERY VEHICLE, FULL TRACKED: MEDIUM, M88A1
NSN 2350-00-122-6826, EIC AQA
MAIN WINCH TROUBLESHOOTING PROCEDURE

INITIAL SETUP:**Tools and Special Tools**

Tool kit, general mechanic's (item 59, WP 0490 00)
 STE/ICE-R kit (item 57, WP 0490 00)

References

WP 0034 00
 WP 0035 00
 WP 0288 00

References (cont.)

WP 0404 00
 WP 0405 00
 WP 0406 00
 WP 0407 00
 WP 0408 00
 WP 0416 00
 WP 0417 00

Troubleshooting Procedure**Main Winch****Symptom**

Main winch malfunctioning.

Malfunction

Main winch fails to operate. Do steps 1 thru 10.

Main winch operates with difficulty. Do steps 2 thru 10.

Main winch creeps with control in neutral or winch brake fails to hold load. Do steps 11 and 12.

Main winch level winder fails to traverse. Do steps 13 and 14.

CORRECTIVE ACTION**NOTE**

The main winch troubleshooting procedures are performed using the main hydraulic system as a fluid power source. If main winch operates using the main hydraulic but not the auxiliary, troubleshoot auxiliary hydraulic system. If main winch operates using the auxiliary hydraulic but not the main hydraulic, troubleshoot main hydraulic system.

1. Attempt operation of the hoisting boom, hoist winch, and spade. If the hoisting boom, hoist winch, and spade do not operate, troubleshoot main hydraulic system and/or auxiliary hydraulic system. If the hoisting boom, hoist winch, and spade operate go to step 2.

CORRECTIVE ACTION –Continued

2. Visually inspect for signs of main winch mechanical failure. If signs of mechanical failure exist, notify Direct Support Maintenance. If no signs of mechanical failure exist, go to step 3.

WARNING

Do not attempt to loosen or tighten hydraulic fittings or lines when system is pressurized. Severe injury or death to personnel may result.

3. Inspect for any damaged or restricted hoses. Replace hoses as necessary (see WP 0407 00). If no damaged or restricted hoses exist, go to step 4.
4. Test for hydraulic motor failure. Remove hose No. 47 from rear of hydraulic motor (see WP 0416 00). A large volume of oil discharged from port when main winch control valve is engaged indicates a faulty motor. If a faulty hydraulic motor exists, notify Direct Support Maintenance. If hydraulic motor is not faulty, go to step 5.
5. Inspect manual control and linkage (see WP 0407 00) for disconnected, damaged, or missing parts. Connect linkage and replace or repair missing or damaged parts (see WP 0406 00). If main winch cable is not damaged and is properly attached to drum, go to step 6.
6. Ensure main winch cable is not damaged and is properly attached to drum. Replace main winch cable if required (see WP 0408 00). If main winch cable is not damaged and is properly attached to drum, go to step 7.
7. Inspect hydraulic lines and fittings for leaks. Replace leaking hydraulic lines and tighten leaking connections (see WP 0416 00). If leaks persist, notify Direct Support Maintenance. If no leaks exist go to step 8.
8. Test main winch combination control valve by performing STE/ICE-R test No. 51 with 0–10,000 psig pressure transducer (item 57, WP 0490 00) installed in test gage port No. 50 at main winch level winder. Remove hose No. 21A from valve, and plug outlet of valve (see WP 0417 00). If no pressure is indicated on gage when operating hydraulic system, it indicates a faulty combination control valve. If combination control valve is faulty, notify Direct Support Maintenance. If combination control valve is not faulty go to step 9.
9. Test the main winch control valve by performing STE/ICE-R test No. 51 with 0–10,000 psig pressure transducer (item 57, WP 0490 00) installed in combination control valve port No. 7. If no pressure is established when actuating control valve, but pressure is established when removing hose No. 21A from control valve and plugging outlet, a faulty main winch control valve is indicated. If main winch control valve is faulty, notify Direct Support Maintenance. If main winch control valve is not faulty, go to step 10.
10. If main winch still does not operate or operates with difficulty, troubleshoot main hydraulic system and/or auxiliary hydraulic system (see WP 0034 00 and 0035 00). If main winch operates properly, but creeps or fails to hold load, go to step 11.

NOTE

Ensure hydraulic system is at operating temperature.

11. If main winch creeps or fails to hold load, adjust brake. Open door of hydraulic valve forward right floor plate (see WP 0288 00). Loosen locknut (see WP 0405 00) and tighten main winch adjusting screw clockwise as far as it will go. Back off adjusting screw one full turn. Hold adjusting screw in position and tighten locknut. If brake fails to hold load or creeps, go to step 12.

CORRECTIVE ACTION –Continued

12. Remove hydraulic brake cylinder hose No. 29 and inspect for restriction (see WP 0416 00). Replace restricted or damaged hose (see WP 0416 00). If no hose restriction or damage exists and brake still fails to hold load or creep, notify Direct Support Maintenance. If level winder fails to traverse, go to step 13.

WARNING

Do not attempt to loosen or tighten hydraulic fittings or lines when system is pressurized. Severe injury or death to personnel may result.

13. Inspect for any damaged or restricted hoses. Replace hoses as necessary (see WP 0416 00). If no damaged or restricted hoses exist, go to step 14.
14. Adjust main winch level winder cylinders (see WP 0404 00). If level winder fails to traverse after cylinder adjustment, notify Direct Support Maintenance.

END OF WORK PACKAGE

UNIT MAINTENANCE
RECOVERY VEHICLE, FULL TRACKED: MEDIUM, M88A1
NSN 2350-00-122-6826, EIC AQA
HOIST WINCH TROUBLESHOOTING PROCEDURE

INITIAL SETUP:**Tools and Special Tools**

Tool kit, general mechanic's (item 59, WP 0490 00)

References

WP 0289 00

References (cont.)

WP 0409 00

WP 0410 00

WP 0411 00

WP 0416 00

Troubleshooting Procedure**Hoist Winch****Symptom**

Hoist winch malfunctioning.

Malfunction

Hoist winch fails to operate. Do steps 1 thru 7.

Hoist winch operates with difficulty. Do steps 2 thru 7.

Hoist winch creeps or fails to hold load. Do steps 8 thru 10.

CORRECTIVE ACTION**NOTE**

The hoist winch troubleshooting procedures are performed using the main hydraulic system as a fluid power source. If hoist winch operates using the main hydraulic but not the auxiliary hydraulic, troubleshoot auxiliary hydraulic system. If hoist winch operates using the auxiliary hydraulic but not the main hydraulic, troubleshoot main hydraulic system.

1. Attempt operation of the hoisting boom, main winch, and spade. If the hoisting boom, main winch, and spade do not operate, troubleshoot main hydraulic system and/or auxiliary hydraulic system. If the hoisting boom, main winch, and spade operate go to step 2.
2. Visually inspect for damage. If signs of mechanical failure exist, notify Direct Support Maintenance. If no signs of mechanical failure exist, go to step 3.

WARNING

Do not attempt to loosen or tighten hydraulic fittings or lines when system is pressurized. Severe injury or death to personnel may result.

3. Inspect for any damaged or restricted hoses. Replace hoses as necessary (see WP 0416 00). If no damaged or restricted hoses exist, go to step 4.

CORRECTIVE ACTION –Continued

4. Test for hydraulic motor failure. Remove hose No. 48 from rear of hydraulic motor (see WP 0416 00). A large volume of oil discharged from port when hoist winch control valve is engaged indicates a faulty motor. If a faulty hydraulic motor exists, notify Direct Support Maintenance. If hydraulic motor is not faulty, go to step 5.
5. Inspect manual control and linkage (see WP 0411 00) for disconnected, damaged, or missing parts. Connect linkage and replace or repair missing or damaged parts (see WP 0411 00). If no control and linkage defects exist, go to step 6.
6. Ensure hoist winch cable is not damaged and is properly attached to drum. Replace hoist winch cable if required (see WP 0409 00). If hoist winch cable is not damaged and is properly attached to drum, go to step 7.

WARNING

Do not attempt to loosen or tighten hydraulic fittings or lines when system is pressurized. Severe injury or death to personnel may result.

7. Inspect hydraulic lines and connections for leaks. Replace leaking hydraulic lines and tighten leaking connections (see WP 0416 00). If leaks persist, notify Direct Support Maintenance. If no leaks exist go to step 8.

NOTE

Ensure hydraulic system is at operating temperature.

8. If hoist winch creeps or fails to hold load, adjust brake. Open door of U-35 winch center right floor plate (see WP 0289 00). Loosen locknut (see WP 0410 00) and tighten hoist winch adjusting screw clockwise as far as it will go. Back off adjusting screw one full turn. Hold adjusting screw in position and tighten locknut. If brake fails to hold load, go to step 9. If brake holds load but continues to creep, notify Direct Support Maintenance.
9. Remove hydraulic brake cylinder hose No. 28 and inspect for restriction (see WP 0416 00). Replace restricted or damaged hose (see WP 0416 00). If no hose restriction or damage exists and brake still fails to hold load, go to step 10.
10. If quick disconnect between hydraulic line, hose No. 22, and hydraulic line hose No. 22A is dirty or damaged, clean or replace quick disconnect as necessary (see WP 0416 00). If no quick disconnect damage is present and hoist winch still creeps or fails to hold load, notify Direct Support Maintenance.

END OF WORK PACKAGE

UNIT MAINTENANCE
RECOVERY VEHICLE, FULL TRACKED: MEDIUM, M88A1
NSN 2350-00-122-6826, EIC AQA
HOISTING BOOM TROUBLESHOOTING PROCEDURE

INITIAL SETUP:**Tools and Special Tools**

Tool kit, general mechanic's (item 59, WP 0490 00)
STE/ICE-R kit (item 57, WP 0490 00)

References

WP 0414 00
WP 0415 00
WP 0416 00
TM 9-2350-256-10

Troubleshooting Procedure**Hoisting Boom****Symptom**

Hoisting boom malfunctioning.

Malfunction

Hoisting boom does not operate. Do steps 1 thru 6.

Hoisting boom operates with difficulty. Do steps 3 thru 10.

Hoisting boom creeps. Do steps 10 and 11.

Boom stayline cables become slack during live boom operation. Do step 12.

CORRECTIVE ACTION**NOTE**

The hoisting boom troubleshooting procedures are performed using the main hydraulic system as a fluid power source. If hoisting boom operates using main hydraulic but not auxiliary hydraulic, troubleshoot auxiliary hydraulic system. If hoisting boom operates using auxiliary hydraulic but not main hydraulic, troubleshoot main hydraulic system.

1. Attempt operation of the hoist winch, main winch, and spade. If hoist winch, main winch, and spade do not operate, troubleshoot main hydraulic system and/or auxiliary hydraulic system. If hoist winch, main winch, and spade operate go to step 2.

CORRECTIVE ACTION –Continued

2. Visually inspect for damage. If damage exists and boom cannot be repaired, replace hoisting boom (see WP 0414 00). If signs of damage exist and can be repaired, notify Direct Support Maintenance. If no signs of damage exist, go to step 3.
3. Visually inspect for any indication of class III oil leak at stayline cylinder and actuating cylinder hydraulic connections. If class III oil leaks are present, tighten fittings (see WP 0416 00). If no leaks are present, go to step 4.

WARNING

Do not attempt to loosen or tighten hydraulic fittings or lines when system is pressurized. Severe injury or death to personnel may result.

4. Inspect for any damaged or restricted hoses. Replace hoses as necessary (see WP 0416 00). If no damaged or restricted hoses exist, go to step 5.
5. Visually inspect for failed or missing boom or hydraulic cylinder attaching pins. If any failed or missing pins exist, notify Direct Support Maintenance. If no failed or missing pins exist, go to step 6.

WARNING

Test equipment must be able to withstand 1950–2050 psi (13,445–14,135 kPa). Improper test equipment could burst during testing and cause personnel injury or death.

6. Test for boom combination control valve failure. Perform STE/ICE-R Test No. 51 with 0–10,000 psig pressure transducer (item 57, WP 0490 00) installed in pilot-operated relief and unloading valve gage port. With the main hydraulic system operating, actuate boom combination control valve lever. If pressure is 1950–2050 psi (13,445–14,135 kPa), go to step 7. If 1950–2050 psi (13,445–14,135 kPa) is not read, notify Direct Support Maintenance.
7. Visually inspect stayline cables to ensure cable connections are intact. If stayline cables are disconnected, reconnect cables as required (see WP 0414 00). If stayline cables are connected, go to step 8.
8. Inspect boom limit valve actuating shaft for binding. Move boom limit valve actuating arm by hand and lubricate shafts (refer to TM 9-2350-256-10). If binding cannot be corrected, notify Direct Support Maintenance. If no binding exists or binding was corrected, go to step 10.
9. Inspect boom limit valve for defective or broken actuating arm linkage. If any defects exist, notify Direct Support Maintenance. If no boom limit valve actuating arm linkage defects exist, go to step 11.

CORRECTIVE ACTION –Continued

10. Inspect boom limit valves for proper adjustment. Adjust boom limit valves (see WP 0415 00). If any defects exist, notify Direct Support Maintenance. If boom still operates with difficulty, notify Support Maintenance. If boom operates properly but creeps (fails to maintain position), go to step 11.

WARNING

Do not attempt to loosen or tighten hydraulic fittings or lines when system is pressurized. Severe injury or death to personnel may result.

11. Inspect hydraulic lines and connections for leaks. Replace leaking hydraulic lines and tighten leaking connections (see WP 0416 00). If leaks persist or boom continues to creep, notify Direct Support Maintenance.
12. Visually inspect stayline cables to ensure cable connections are intact. Adjust stayline cylinder limit valves (see WP 0415 00). If cables still become slack after adjustment, notify Direct Support Maintenance.

END OF WORK PACKAGE

UNIT MAINTENANCE
RECOVERY VEHICLE, FULL TRACKED: MEDIUM, M88A1
NSN 2350-00-122-6826, EIC AQA
SPADE TROUBLESHOOTING PROCEDURE

INITIAL SETUP:**Tools and Special Tools**

Tool kit, general mechanic's (item 59, WP 0490 00)

References

WP 0034 00

WP 0035 00

WP 0416 00

Troubleshooting Procedure**Spade****Symptom**

Spade malfunctioning.

Malfunction

Spade fails to operate. Do steps 1 thru 6.

Spade operates with difficulty. Do steps 1 thru 8.

Spade creeps. Do steps 7 and 8.

CORRECTIVE ACTION**NOTE**

The spade troubleshooting procedures are performed using the main hydraulic system as a fluid power source. If spade operates using main hydraulic but not auxiliary hydraulic, troubleshoot auxiliary hydraulic system. If spade operates using auxiliary hydraulic but not main hydraulic, troubleshoot main hydraulic system.

1. Attempt operation of the hoisting boom, hoist winch, and main winch. If hoisting boom, hoist winch, and main winch do not operate, troubleshoot main hydraulic system and/or auxiliary hydraulic system. If hoisting boom, hoist winch, and main winch operate go to step 2.

WARNING

Do not attempt to loosen or tighten hydraulic fittings or lines when system is pressurized. Severe injury or death to personnel may result.

2. Inspect hydraulic lines and connections for leaks. Replace leaking hydraulic lines and tighten leaking connections (see WP 0416 00). If leaks persist, notify Direct Support Maintenance. If no leaks persist go to step 3.

CORRECTIVE ACTION –Continued

WARNING

Do not attempt to loosen or tighten hydraulic fittings or lines when system is pressurized. Severe injury or death to personnel may result.

3. Visually inspect for any indication of oil leakage at spade cylinders, spade release cylinder, and cylinder hydraulic connections. If oil leaks cannot be stopped by tightening fittings, notify Direct Support Maintenance. If oil leaks are not present, go to step 4.
4. Visually inspect for signs of mechanical failure of spade. If signs of mechanical failure exist, notify Direct Support Maintenance. If no signs of mechanical failure exist, go to step 5.
5. Visually inspect for failed or missing spade cylinder attaching pins. If any failed or missing pins exist, notify Direct Support Maintenance. If no failed or missing pins exist, go to step 7.

WARNING

Test equipment must be able to withstand 1950–2050 psi (13,445–14,135 kPa). Improper test equipment could burst during testing and cause personnel injury or death.

6. If spade still does not operate, troubleshoot main hydraulic system and/or auxiliary hydraulic system (see WP 0034 00 and 0035 00). If spade operates, but with difficulty, go to step 7.
7. Inspect for galled spade pivot pins. If any damaged pins exist, notify Direct Support Maintenance. If no damaged pivot pins exist, go to step 8.
8. Inspect hydraulic lines and connections for leaks. Replace leaking hydraulic lines and tighten leaking connections (see WP 0416 00). If leaks persist or spade continues to operate with difficulty, notify Direct Support Maintenance. If no leaks exist and spade still creeps, notify Direct Support Maintenance.

END OF WORK PACKAGE

UNIT MAINTENANCE
RECOVERY VEHICLE, FULL TRACKED: MEDIUM, M88A1
NSN 2350-00-122-6826, EIC AQA
MAIN HYDRAULIC SYSTEM TROUBLESHOOTING PROCEDURE

INITIAL SETUP:**Tools and Special Tools**

Tool kit, general mechanic's (item 59, WP 0490 00)
 Kit assembly, gage, pressure (item 31, WP 0490 00)

References

WP 0098 00
 WP 0296 00
 WP 0342 00
 WP 0418 00

Materials/Parts

Compound, cleaning (item 9, WP 0489 00)

Troubleshooting Procedure**Main Hydraulic System****Symptom**

Main hydraulic system malfunctioning.

Malfunction

Insufficient or no main system oil pressure. Do steps 1 thru 5.
 Loss of main hydraulic pressure during operation. Do steps 1 thru 7.

CORRECTIVE ACTION

1. Remove hydraulic line intermediate rear right center floor plate (see WP 0296 00). Remove eight socket head screws. Remove hydraulic oil filter cover and oil filter element (see WP 0418 00).

WARNING

Solvents can burn easily, can give off harmful vapors, and are harmful to skin and clothing. To avoid injury or death, keep away from open flame and use in a well-ventilated area. If solvent gets on skin or clothing, wash immediately with soap and water.

WARNING

Particles blown by compressed air can be dangerous. Be certain to direct airstream away from user and other personnel in the area. Compressed air used for cleaning purposes will not exceed 30 psi. Use only with effective chip-guarding and personnel protective equipment (goggles/shield and gloves).

Clean hydraulic oil filter element with cleaning compound (item 9, WP 0489 00) and dry with compressed air. Install filter element and cover and go to step 2.

CORRECTIVE ACTION –Continued

2. Remove left- and center-front air inlet grilles (see WP 0342 00). Inspect power takeoff coupling to see that drive shaft is firmly attached to power takeoff coupling. Tighten bolts and/or replace missing bolts and lockwashers and go to step 3.

WARNING

Keep hands and arms away from fan blade and drive while engine is running, or serious injury to personnel will result.

3. Have assistant start engine. Observe power takeoff coupling and drive shaft. If they are not turning, remove powerplant (see WP 0098 00). Tighten power takeoff retaining nut. Torque nut to 240–250 lb-ft (1655–1724 N•m) and go to step 4.
4. Remove hydraulic line intermediate rear right center floor plate (see WP 0296 00). Remove pipe plug from mechanical transmission and install pressure gage (item 31, WP 0490 00). Operate engine at 1600 rpm. Lubricating oil pressure should be 10–19 psi (69–131 kPa). If lubricating oil pressure is 10–19 psi (69–131 kPa), go to step 5. If lubricating oil pressure is not 10–19 psi (69–131 kPa), notify Direct Support Maintenance.
5. Disconnect hydraulic line. Install tee and pressure gage (item 31, WP 0490 00). Connect hydraulic line. Operate engine at 1600 rpm. Mechanical transmission clutch operating pressure should be 140–225 psi (965–1551 kPa). If clutch pressure is 140–225 psi (965–1551 kPa), go to step 6. If clutch pressure is not 140–225 psi (965–1551 kPa), notify Direct Support Maintenance.
6. Inspect hydraulic lines and connections for damage and leaks. Replace hydraulic lines and connections that show signs of damage. Tighten connections that leak. If leaks persist, notify Direct Support Maintenance.
7. Inspect hydraulic components (valves, pumps, cylinders, etc.) for leaks at gaskets and/or seals. Tighten loose covers, plates, and housings. If leaks persist, notify Direct Support Maintenance.

END OF WORK PACKAGE

UNIT MAINTENANCE
RECOVERY VEHICLE, FULL TRACKED: MEDIUM, M88A1
NSN 2350-00-122-6826, EIC AQA
AUXILIARY HYDRAULIC SYSTEM TROUBLESHOOTING PROCEDURE

INITIAL SETUP:**Tools and Special Tools**

Tool kit, general mechanic's (item 59, WP 0490 00)

Troubleshooting Procedure**Auxiliary Hydraulic System****Symptom**

Auxiliary hydraulic system malfunctioning.

Malfunction

Main and hoist winches fail to operate. Do step 1.

Insufficient or no auxiliary system oil pressure. Do step 1.

Loss of auxiliary hydraulic pressure during operation. Do steps 2 and 3.

CORRECTIVE ACTION

1. Check auxiliary power unit emergency winch control valve to see if it is in AUXILIARY POWER UNIT OPERATION (open) position. If valve is not in correct position, place in open position.

WARNING

Do not attempt to loosen or tighten hydraulic fittings or lines when system is pressurized. Severe injury or death to personnel may result.

2. Inspect hydraulic lines and connections for damage and leaks. Tighten connections that leak. If leaks persist, notify Direct Support Maintenance.
3. Inspect hydraulic components (valves, pumps, cylinders, etc.) for leaks at gaskets and/or seals. Tighten loose covers, plates, or housings. If leaks persist, notify Direct Support Maintenance.

END OF WORK PACKAGE

UNIT MAINTENANCE
RECOVERY VEHICLE, FULL TRACKED: MEDIUM, M88A1
NSN 2350-00-122-6826, EIC AQA
APU TROUBLESHOOTING PROCEDURE

INITIAL SETUP:**Tools and Special Tools**

Tool kit, general mechanic's (item 59, WP 0490 00)

References

WP 0059 00

WP 0062 00

References (cont.)

WP 0334 00

WP 0433 00

WP 0436 00

TM 9-2350-256-10

Troubleshooting Procedure**APU****Symptom**

APU malfunctioning.

Malfunction

Engine fails to crank when starting switch is operated. Do steps 1 and 2.

Engine cranks but fails to start. Do steps 3 and 7.

Engine hard to start. Do steps 4 thru 6, 8, and 10.

Engine starts but fails to keep running, or lacks power. Do steps 8, and 11 thru 13.

Engine overheating. Do steps 13 and 14.

Engine discharges black smoke. Do steps 16 and 17.

Engine knocks. Do step 1.

Engine uses excessive oil and discharges light blue smoky exhaust. Do step 18.

CORRECTIVE ACTION

1. Remove APU access cover (see WP 0334 00). Check for loose electrical connections. Clean and tighten connections if loose.
2. Troubleshoot APU engine starter circuit (see WP 0059 00).
3. Remove APU access cover (see WP 0334 00). Check vehicle tank and APU engine fuel supply line for restrictions or damage. Clean fuel line or replace if necessary (see WP 0436 00).
4. Remove APU access cover (see WP 0334 00). Check fuel system for water. Bleed water at filters (see WP 0436 00).
5. Check for leaking APU fuel lines or fittings. Tighten or replace defective lines or fittings.
6. Check for dirty fuel filters. Replace fuel filter elements (see WP 0436 00).
7. Remove access cover (see WP 0334 00). Troubleshoot fuel solenoid circuit (see WP 0059 00). If fuel solenoid is defective, notify Direct Support Maintenance.

CORRECTIVE ACTION –Continued

8. Remove APU access cover (see WP 0334 00). Check for dirty air cleaner filter element. Clean or replace filter element (see WP 0433 00).
9. Check air preheater and glow plugs for malfunction by troubleshooting APU starter circuit.
10. Check PREHEAT switch on APU control box for malfunction by troubleshooting APU starter circuit.
11. Check for clogged fuel lines. Clean or replace lines (see WP 0436 00).
12. Check for dirty fuel filters. Clean or replace filters as necessary (see WP 0436 00).
13. Remove APU access cover (see WP 0334 00). Check that all air intake tubes and passages are free of obstructions. Remove obstructions from air intake tubes and passages.
14. Check high engine temperature sending unit. Troubleshoot APU high air temperature circuit (see WP 0062 00). If defective, notify Direct Support Maintenance.
15. Check for air in fuel supply system. Bleed fuel lines at fuel filters (see WP 0436 00).
16. Remove APU access cover (see WP 0334 00). Check fuel for contamination. If contaminated fuel is found, drain fuel tanks and fill with uncontaminated fuel (refer to TM 9-2350-256-10).
17. Check air intake tubes for restrictions. If restrictions are found, clean or replace tubes (see WP 0433 00).
18. Notify Direct Support Maintenance.

END OF WORK PACKAGE

UNIT MAINTENANCE
RECOVERY VEHICLE, FULL TRACKED: MEDIUM, M88A1
NSN 2350-00-122-6826, EIC AQA
MAIN HYDRAULIC PUMP TROUBLESHOOTING PROCEDURE

INITIAL SETUP:**Tools and Special Tools**

Tool kit, general mechanic's (item 59, WP 0490 00)

Materials/Parts

Compound, cleaning (item 9, WP 0489 00)

References

WP 0303 00

WP 0416 00

WP 0418 00

Troubleshooting Procedure**Main Hydraulic Pump****Symptom**

Main hydraulic pump malfunctioning.

Malfunction

Main hydraulic pump fails to operate. Do steps 1 thru 5.

Main hydraulic pump fails to develop sufficient pressure. Do steps 3 thru 6.

Main hydraulic pump is noisy during operation. Do steps 3 thru 6.

CORRECTIVE ACTION

1. Ensure system selector control lever is in the MAIN position. If problem persists, go to step 2.
2. Test for defective power control valve or restricted hose. Remove hose No. 66 from mechanical transmission (see WP 0416 00). With mechanical transmission drive shaft rotating, and power control valve lever placed in ON position, oil should flow from hose.
 - a. If no oil flows from hose, check hose for damage or restriction and replace as necessary (see WP 0416 00). If oil flow cannot be restored, go to step 4. If oil flows, go to step 3. If mechanical transmission drive shaft does not rotate, notify Direct Support Maintenance.
 - b. If no oil flows from hose after checking hoses and replacing as necessary, this indicates a defective power control valve. Notify Direct Support Maintenance.
3. Inspect main hydraulic pump drive shaft. If shaft is rotating, go to step 4. If shaft is not rotating, go to step 5.

WARNING

Do not attempt to loosen or tighten hydraulic fittings or lines when system is pressurized. Severe injury or death to personnel may result.

4. Inspect all hydraulic hoses and connections for visible indication of leaks or damage. Replace hydraulic hoses and tighten fittings as necessary (see WP 0416 00). If problem persists, go to step 5.
5. Inspect main hydraulic pump for broken or damaged shaft coupling. Tighten bolts and/or replace missing bolts and lockwashers (see WP 0416 00). If additional damage is present or main hydraulic

CORRECTIVE ACTION –Continued

pump still does not operate, notify Direct Support Maintenance. If main hydraulic pump operates but is noisy or fails to develop sufficient pressure and no additional shaft coupling damage is present, go to step 6.

WARNING

Solvents can burn easily, give off harmful vapors, and are harmful to skin and clothing. To avoid injury or death, keep away from open flame and use in a well-ventilated area. If solvent gets on skin or clothing, wash immediately with soap and water.

WARNING

Particles blown by compressed air can be dangerous. Be certain to direct air stream away from user and other personnel in the area. Compressed air used for cleaning purposes will not exceed 30 psi (207 kPa). Use only with effective chip-guarding and personal protective equipment (goggle/shield and gloves).

6. Remove center rear floor plate (see WP 0303 00). Remove eight socket head screws and remove hydraulic oil filter cover and oil filter element (see WP 0418 00). Clean hydraulic oil filter element with cleaning compound (item 9, WP 0489 00) and dry with compressed air. Replace filter element and cover. If problem persists notify Direct Support Maintenance.

END OF WORK PACKAGE

UNIT MAINTENANCE
RECOVERY VEHICLE, FULL TRACKED: MEDIUM, M88A1
NSN 2350-00-122-6826, EIC AQA
AUXILIARY HYDRAULIC PUMP TROUBLESHOOTING PROCEDURE

INITIAL SETUP:**Tools and Special Tools**

Tool kit, general mechanic's (item 59, WP 0490 00)

References

WP 0416 00

Troubleshooting Procedure**Auxiliary Hydraulic Pump****Symptom**

Auxiliary hydraulic system malfunctioning.

Malfunction

Main and hoist winches fail to operate. Do step 1.

Insufficient or no auxiliary system oil pressure. Do step 1.

Loss of auxiliary hydraulic pressure during operation. Do steps 2 and 3.

CORRECTIVE ACTION

1. Ensure SYSTEM SELECTOR CONTROL lever is in the AUXILIARY or REFUEL position (not MAIN position) as appropriate. If problem persists, go to step 2.
2. Ensure APU emergency winch control valve lever is in the AUXILIARY POWER UNIT OPERATION (open) position. If problem persists, go to step 3.
3. Ensure power control lever is in the OFF position. If problem persists, go to step 4.

WARNING

Do not attempt to loosen or tighten hydraulic fittings or lines when system is pressurized. Severe injury or death to personnel may result.

4. Inspect all hydraulic hoses and connections for visible indication of leaks or damage. Replace hydraulic hoses and tighten fittings as necessary (see WP 0416 00). If problem persists, notify Direct Support Maintenance.

END OF WORK PACKAGE

UNIT MAINTENANCE
RECOVERY VEHICLE, FULL TRACKED: MEDIUM, M88A1
NSN 2350-00-122-6826, EIC AQA

MECHANICAL TRANSMISSION—HYDRAULIC TROUBLESHOOTING PROCEDURE

INITIAL SETUP:**Tools and Special Tools**

Tool kit, general mechanic's (item 59, WP 0490 00)

References

WP 0416 00

Troubleshooting Procedure**Mechanical Transmission—Hydraulic****Symptom**

Mechanical transmission malfunctions.

Malfunction

Mechanical transmission fails to operate, slips, or chatters.

CORRECTIVE ACTION

WARNING

Do not attempt to loosen or tighten hydraulic fittings or lines when system is pressurized. Severe injury or death to personnel may result.

1. Inspect all hydraulic hoses and connections for visible indication of leaks or damage. Replace hydraulic hoses and tighten fittings as necessary (see WP 0416 00). If problem persists, notify Direct Support Maintenance.

END OF WORK PACKAGE

UNIT MAINTENANCE
RECOVERY VEHICLE, FULL TRACKED: MEDIUM, M88A1
NSN 2350-00-122-6826, EIC AQA

**SIMPLIFIED TEST EQUIPMENT/INTERNAL COMBUSTION ENGINE-
REPROGRAMMABLE (STE/ICE-R) TROUBLESHOOTING PROCEDURE**

INITIAL SETUP:

Tools and Special Tools

Tool kit, general mechanic's (item 59, WP 0490 00)
STE/ICE-R kit (item 57, WP 0490 00)

References

TM 9-4910-571-12&P

Troubleshooting Procedure

Simplified Test Equipment/Internal Combustion Engine-Reprogrammable (STE/ICE-R)

Symptom

Engine malfunctioning.

Malfunction

Apparent engine failure.

Apparent transmission failure.

Apparent battery or generator failure.

CORRECTIVE ACTION

The STR/ICE kit provides an evaluation for troubleshooting various engine failure symptoms.

The STE/ICE-R Vehicle Test Meter (VTM) provides a digital readout for displaying measurement results of the engine, transmission, and battery / generator. This section contains the following:

1. How to use STE/ICE-R set (refer to TM 9-4910-571-12&P).
2. M88A1 Test Procedures Table (an index of the STE/ICE-R tests and Test Limits).
3. VTM General Setup, Confidence and Identification tests, 66/60 (refer to TM 9-4910-571-12&P).

Table 1. M88A1 Test Procedures

Test No.	Title	Limits	
		Min.	Max.
10	Engine Rpm Test	2550	2640
13	C1 Governor Check and Power Test	75	
14	Compression Unbalance Test	0	15
49	Pressure Test, 0–25 Psig	1	
50	Pressure 0–1000 Psig Test	42	
66/60	VTM General Setup Confidence and Identification Test	04	04
67	Charging Circuit and Battery Voltage Test	27	30
72	Starter Current First Peak Test	695	1185
74	Starter Circuit Resistance Test	10	60
89	DC Voltage Test*		
90	DC Current Test*		
91/92	Resistance and Continuity Check Test*		

* Limits will vary per vehicle.

END OF WORK PACKAGE

UNIT MAINTENANCE
RECOVERY VEHICLE, FULL TRACKED: MEDIUM, M88A1
NSN 2350-00-122-6826, EIC AQA
BATTERY POWER CIRCUIT TROUBLESHOOTING PROCEDURE

INITIAL SETUP:

Tools and Special Tools

Tool kit, general mechanic's (item 59, WP 0490 00)

References

WP 0153 00
 TM 9-2350-256-10

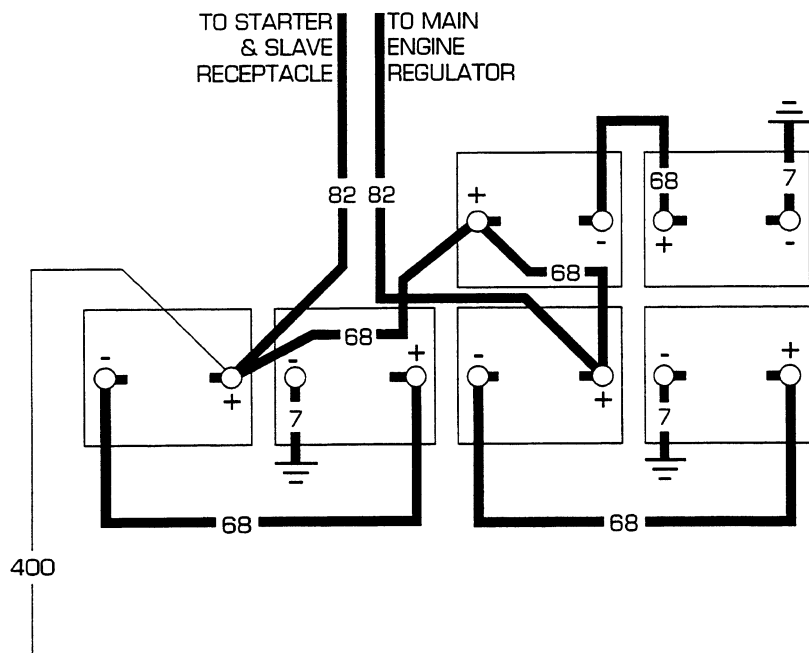
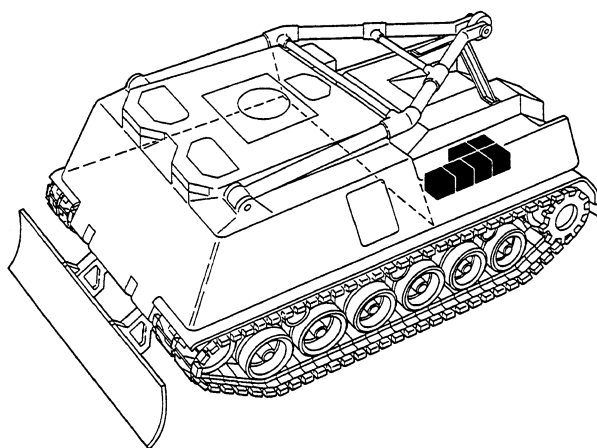

Troubleshooting Procedure

Battery Power Circuit

Symptom

Battery power circuit malfunctioning.

Malfunction

Generator gage indicates low battery charge. Do steps 1 and 2.

CORRECTIVE ACTION

WARNING

Remove all jewelry such as rings, dog tags, bracelets, etc. If jewelry contacts a metal surface a direct short may result in instant heating of tools, damage to equipment, and injury or death to personnel.

1. Open air inlet doors (TM 9-2350-256-10). Place red multimeter lead on positive post and black lead to ground. Check for voltage. If voltage is below 18 V dc, clean, tighten, repair, or replace necessary cables. Crank engine and check voltage. If voltage is still below 18 V dc, go to step 2.

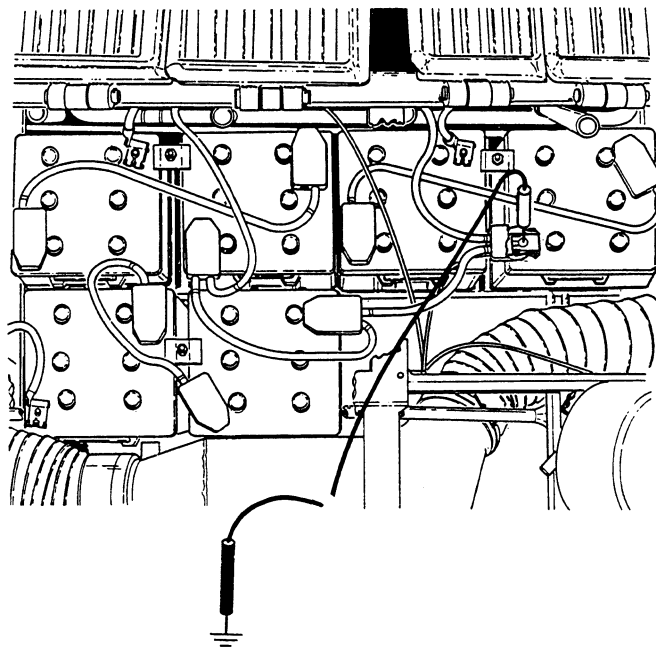

2. Place red multimeter lead on positive post and black lead on negative post of battery 1. Voltage reading should not be below 9 V dc. Repeat on batteries 2, 3, 4, 5, and 6. If any battery voltage is below 9 V dc replace battery (see WP 0153 00).

END OF WORK PACKAGE

UNIT MAINTENANCE
RECOVERY VEHICLE, FULL TRACKED: MEDIUM, M88A1
NSN 2350-00-122-6826, EIC AQA

MASTER RELAY AND SLAVE RECEPTACLE TROUBLESHOOTING PROCEDURE

INITIAL SETUP:

Tools and Special Tools

Tool kit, general mechanic's (item 59, WP 0490 00)

References

WP 0159 00

WP 0190 00

WP 0191 00

References (cont.)

WP 0201 00

WP 0219 00

WP 0220 00

WP 0226 00

TM 9-2350-256-10

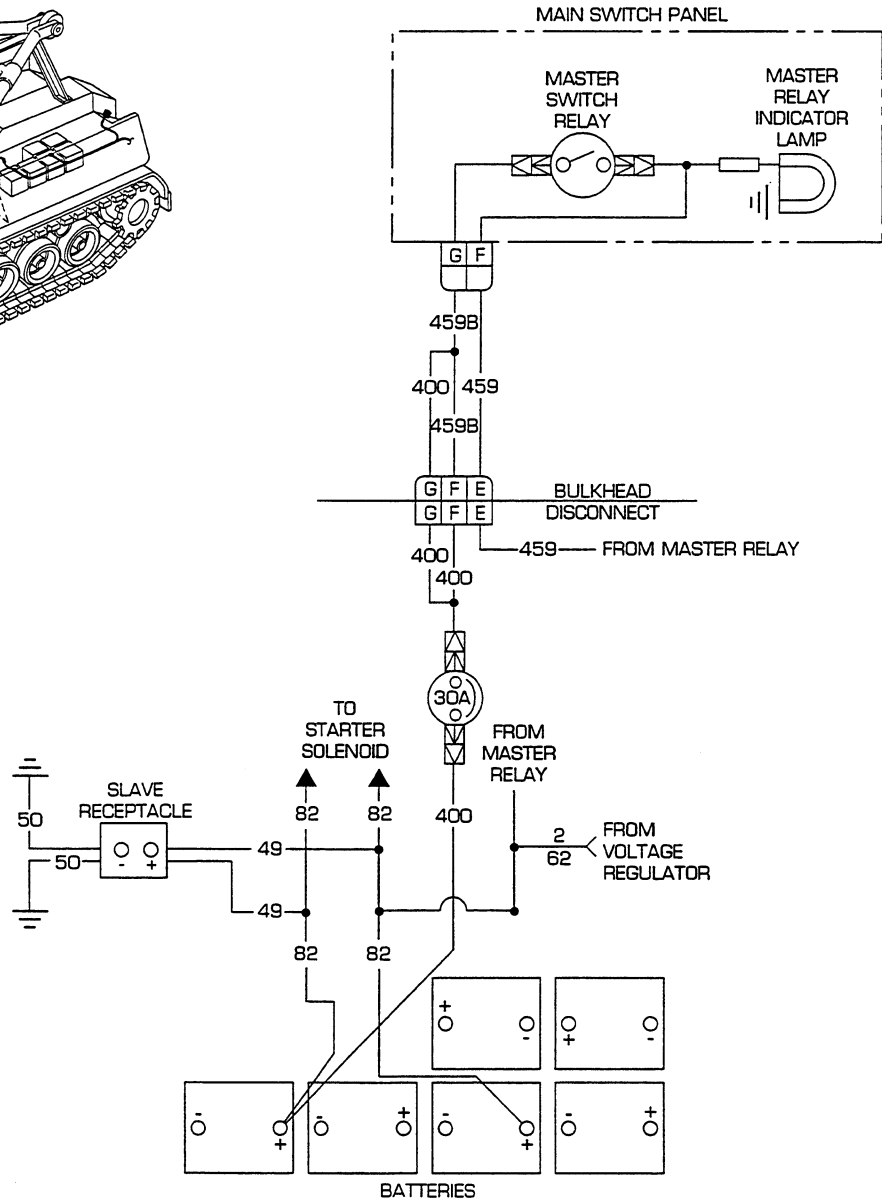
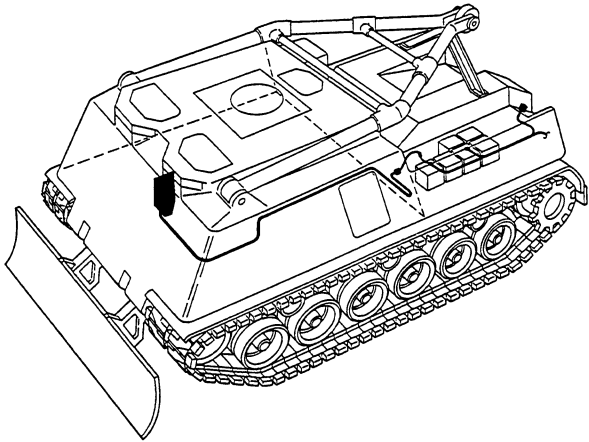

Troubleshooting Procedure**Master Relay and Slave Receptacle****Symptom**

Master relay or slave receptacle malfunctioning.

Malfunction

Master relay fails to operate. Do steps 1 thru 7.

No power to slave receptacle. Do steps 8 and 9.

CORRECTIVE ACTION**WARNING**

Remove all jewelry such as rings, dog tags, bracelets, etc. If jewelry contacts a metal surface a direct short may result in instant heating of tools, damage to equipment, and injury or death to personnel.

1. Remove master relay lamp from socket. Place red lead of multimeter in socket and black lead to ground. Turn MASTER switch on and check for voltage. Turn MASTER switch OFF. If voltage is present, replace lamp (see WP 0159 00). If voltage is not present, go to step 2.

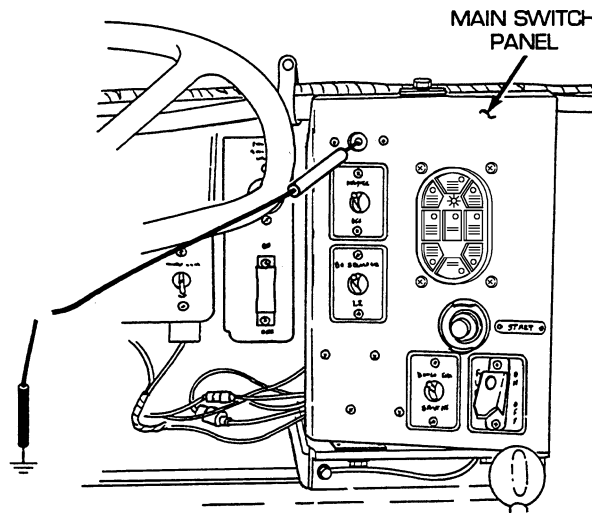

CORRECTIVE ACTION –Continued

- Remove three screws (1), three lockwashers (2), ground lead (3), flat washer (4), and release main switch panel (5) from mounting brackets. Ground panel housing. Disconnect wire 459 from MASTER switch. Place red lead of multimeter on switch terminal and black lead to ground. Turn MASTER switch on and check for voltage. Turn MASTER switch OFF. If voltage is present, repair/replace wire 459 from MASTER switch to lamp connector (see WP 0219 00). If voltage is not present, go to step 3.

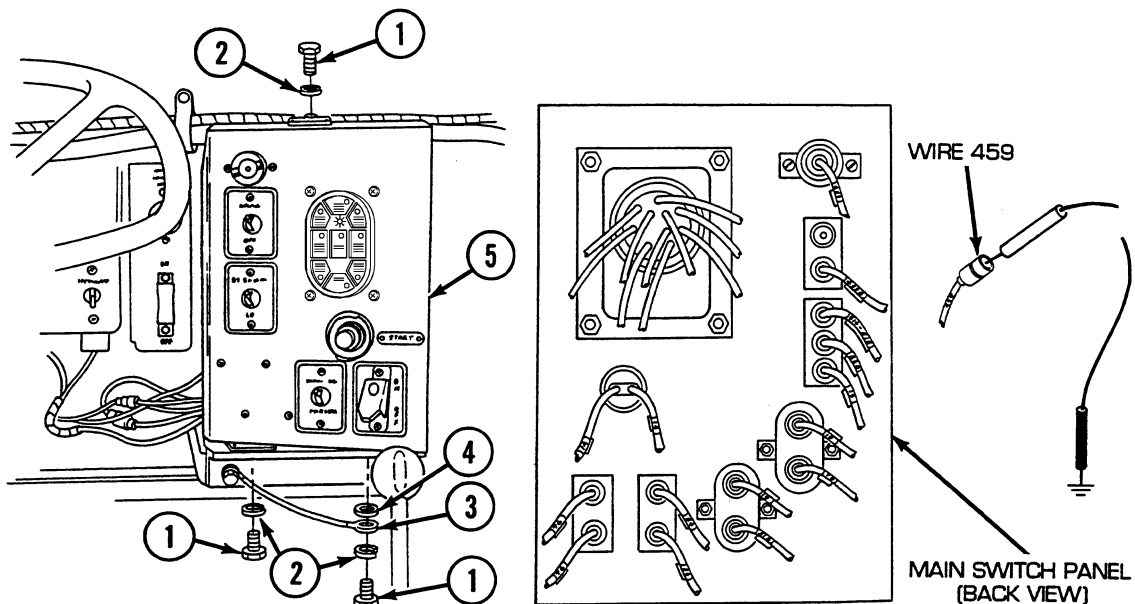

- Reconnect wire 459 MASTER switch. Disconnect wire 459B from MASTER switch. Place red lead of multimeter in wire 459B and black lead to ground. Turn MASTER switch on and check for voltage. Turn MASTER switch OFF. If voltage is present, replace master switch (see WP 0159 00). If voltage is not present, go to step 4.

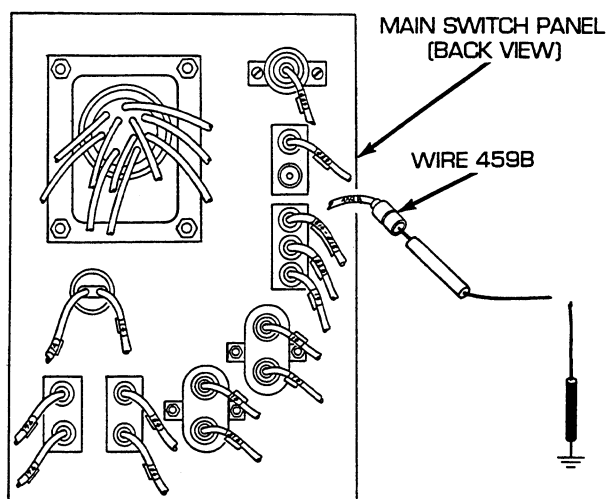

- Reconnect wire 459B to MASTER switch. Disconnect switch panel to head lamps and bulkhead wiring harness from main switch panel. Place red lead of multimeter in socket G of wire 459B and black lead to ground. Turn MASTER switch on and check for voltage. Turn MASTER switch OFF. If voltage is present, replace/repair wire 459B of switch panel. If voltage is not present, go to step 5.

CORRECTIVE ACTION –Continued

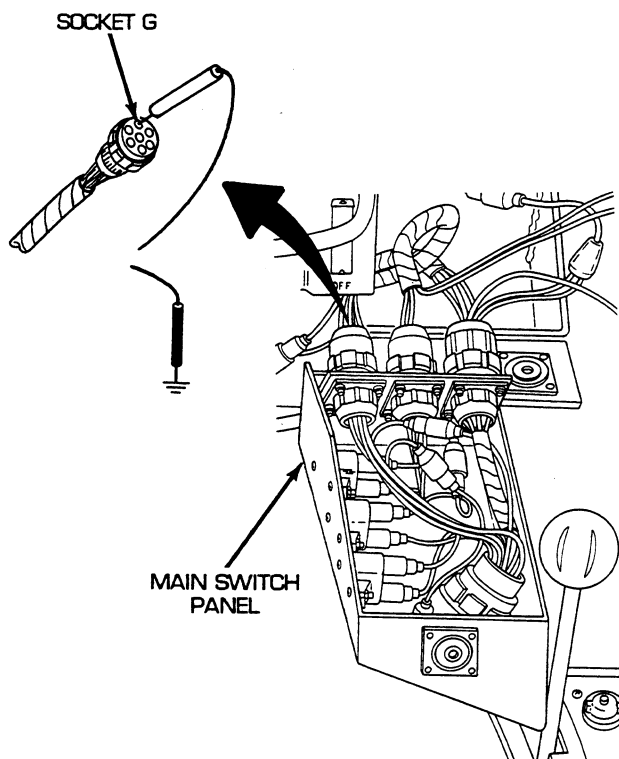

5. Reconnect switch panel to head lamps and bulkhead wiring harness to main switch panel. Install main switch panel (5), flat washer (4), ground lead (3), three lockwashers (2), and three screws (1) to mounting brackets. Open air inlet doors (TM 9-2350-256-10). Disconnect bulkhead to master relay and left and right taillight wiring harness from bulkhead disconnect. Place red lead of multimeter on pin F of wire 400 and black lead to ground. Turn MASTER switch on and check for voltage. Turn MASTER switch OFF. Place red lead of multimeter on pin G of wire 400 and black lead to ground. Turn MASTER switch on and check for voltage. Turn MASTER switch off. If voltage is present replace/repair wire 459B of switch panel to head lamps and bulkhead wiring harness (see WP 0201 00). If voltage is not present, go to step 6.

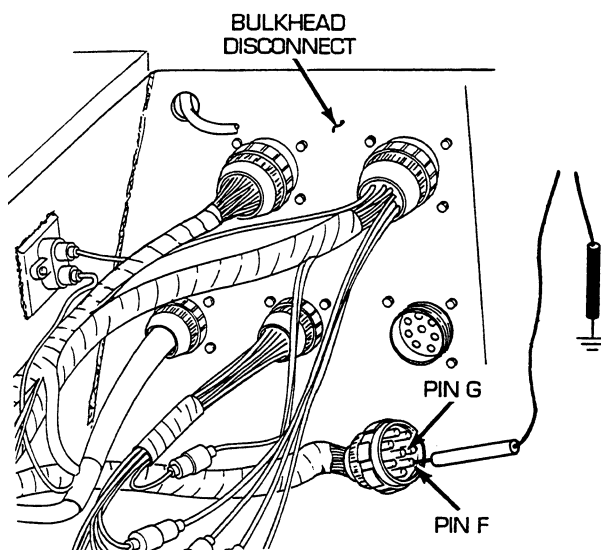

CORRECTIVE ACTION –Continued

6. Reconnect bulkhead to master relay and left and right taillight wiring harness to bulkhead disconnect. Disconnect wire 400 from bulkhead side of 30 ampere (A) circuit breaker. Place red lead of multimeter on terminal of circuit breaker and black lead to ground. Turn MASTER switch on and check for voltage. Turn MASTER switch off. If voltage is present, replace/repair wire 400 of bulkhead to master relay and left and right taillight wiring harness from 30 A circuit breaker to bulkhead (see WP 0220 00). If voltage is not present, go to step 7.

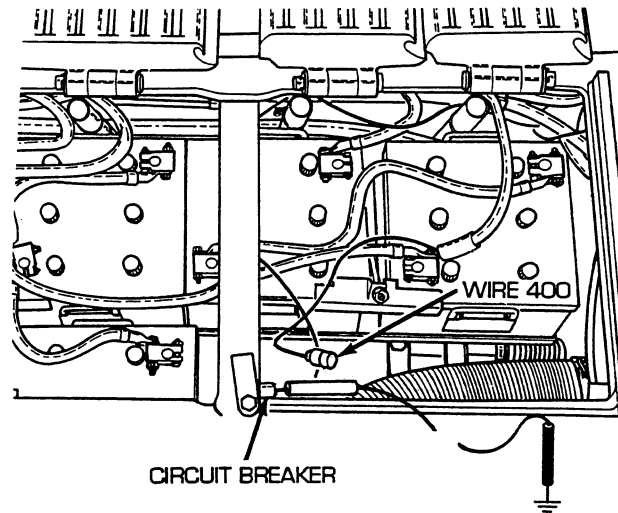

7. Reconnect wire 400 to bulkhead side of 30 A circuit breaker. Disconnect wire 400 from battery side of 30 A circuit breaker. Place red lead of multimeter in wire 400 and black lead to ground. Turn MASTER switch on and check for voltage. Turn MASTER switch off. If voltage is present, replace 30 A circuit breaker. If voltage is not present, troubleshoot battery circuit.

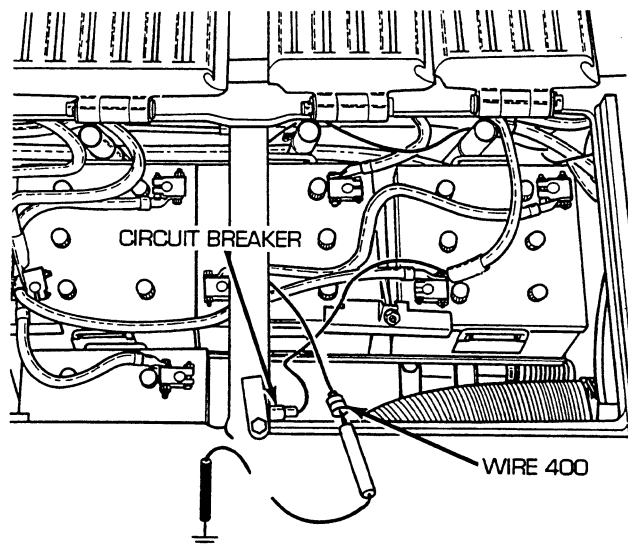

CORRECTIVE ACTION –Continued

8. Close air inlet doors (TM 9-2350-256-10). Raise boom (TM 9-2350-256-10). Open air inlet doors. Place red lead of multimeter on wire 49 at positive terminal and black lead to ground. Turn MASTER switch on and check for voltage. Turn MASTER switch OFF. If voltage is present, go to step 9. If voltage is not present, replace/repair wire 49 of batteries to master relay, voltage regulators, slave receptacle, and engine disconnect wiring harness (see WP 0190 00 for dual voltage; 0191 00 for single voltage).

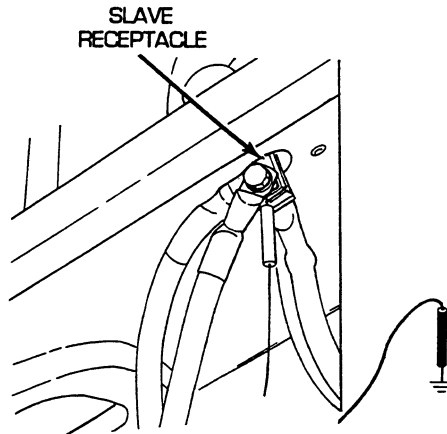

9. Place red lead of multimeter on wire 50 at negative terminal and black lead to ground. Check for continuity. If continuity is present, replace rear slave receptacle (see WP 0226 00). If continuity is not present, replace/repair bulkhead rear slave receptacle wiring harness (see WP 0226 00).

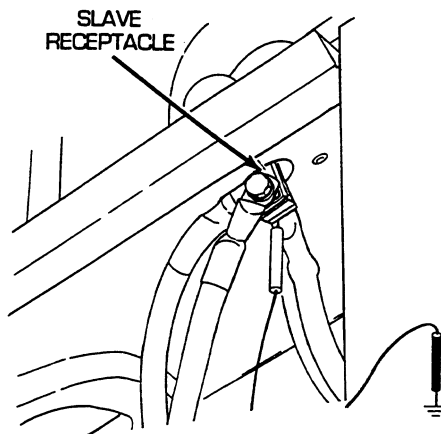
**END OF WORK PACKAGE**

UNIT MAINTENANCE
RECOVERY VEHICLE, FULL TRACKED: MEDIUM, M88A1
NSN 2350-00-122-6826, EIC AQA
ENGINE STARTING SYSTEM TROUBLESHOOTING PROCEDURE

INITIAL SETUP:**Tools and Special Tools**

Tool kit, general mechanic's (item 59, WP 0490 00)

References

WP 0098 00
WP 0099 00
WP 0152 00
WP 0159 00
WP 0163 00
WP 0189 00

References (cont.)

WP 0190 00
WP 0191 00
WP 0203 00
WP 0221 00
WP 0222 00
WP 0223 00
WP 0336 00
TM 9-2350-256-10

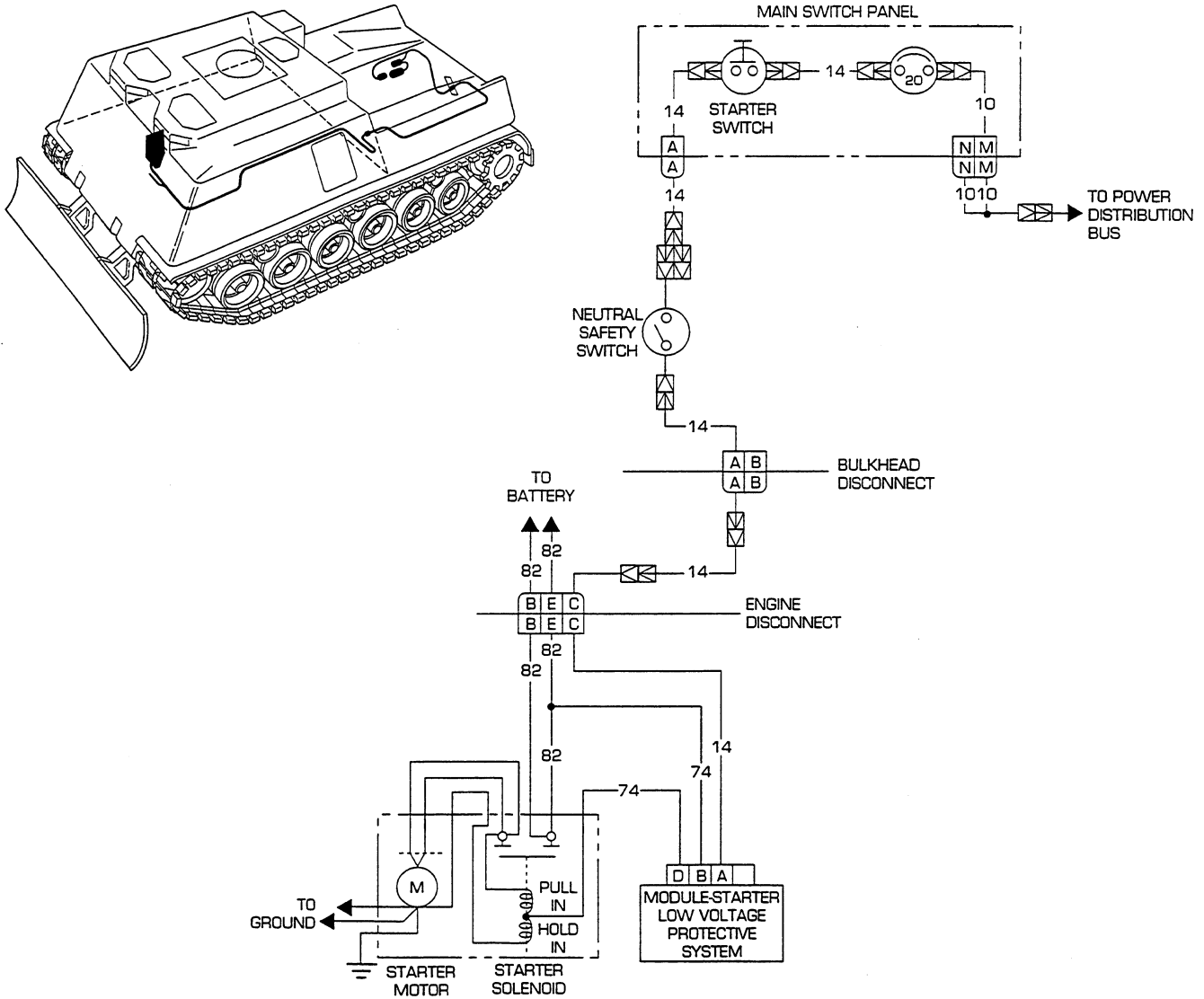

Troubleshooting Procedure

Engine Starting System

Symptom

Engine starting system malfunctioning.

Malfunction

Engine fails to crank. Do steps 1 thru 14.

CORRECTIVE ACTION**WARNING**

Remove all jewelry such as rings, dog tags, bracelets, etc. If jewelry contacts a metal surface a direct short may result in instant heating of tools, damage to equipment, and injury or death to personnel.

1. Remove three screws (1), three lockwashers (2), ground lead (3), and flat washer (4) and release main switch panel (5) from mounting brackets. Disconnect wire 14 from START switch side of circuit breaker. Place red lead of multimeter on terminal of circuit breaker and black lead to ground. Turn MASTER switch on and check for voltage. Turn MASTER switch OFF. If voltage is present, go to step 2. If voltage is not present, go to step 12.

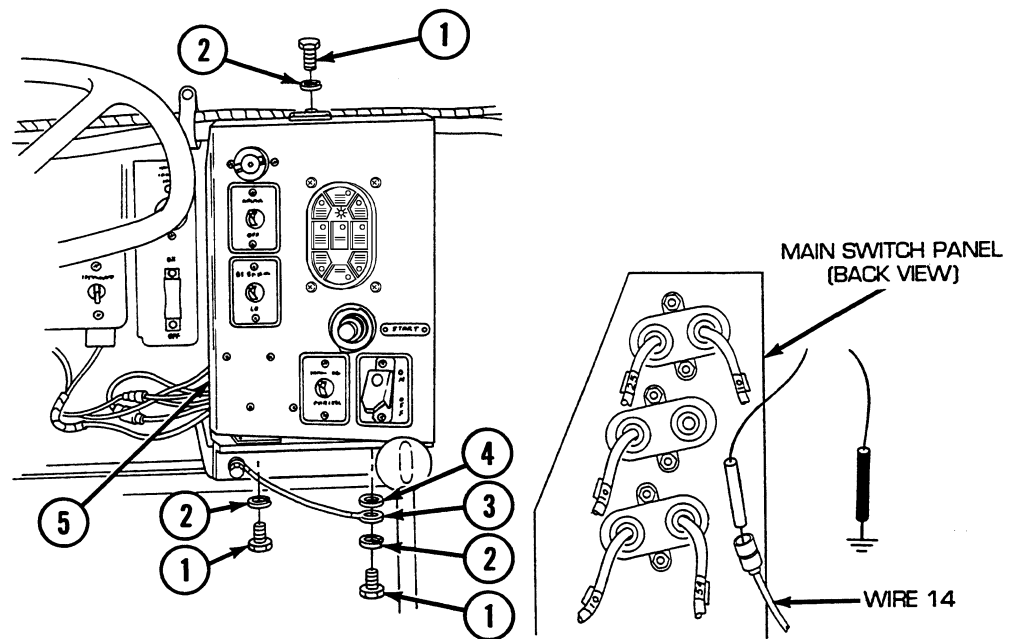

CORRECTIVE ACTION –Continued

2. Reconnect wire 14 to circuit breaker side of START switch. Disconnect wire 14 from panel side of START switch. Place red lead of multimeter on START switch terminal and black lead to ground. Turn MASTER switch on, push START switch, and check for voltage. Turn MASTER switch OFF. If voltage is present, go to step 3. If voltage is not present, replace START switch (see WP 0159 00).

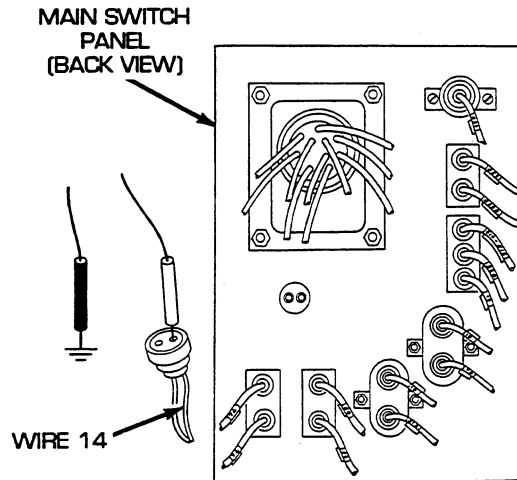

3. Disconnect switch panel to neutral safety to bulkhead wiring harness from main switch panel. Place red lead of multimeter in socket A, of wire 14 and black lead to ground. Turn MASTER switch on, push START switch, and check for voltage. Turn MASTER switch OFF. If voltage is not present, replace/repair wire 14 of circuit breaker to main switch panel wiring harness. If voltage is present, go to step 4.

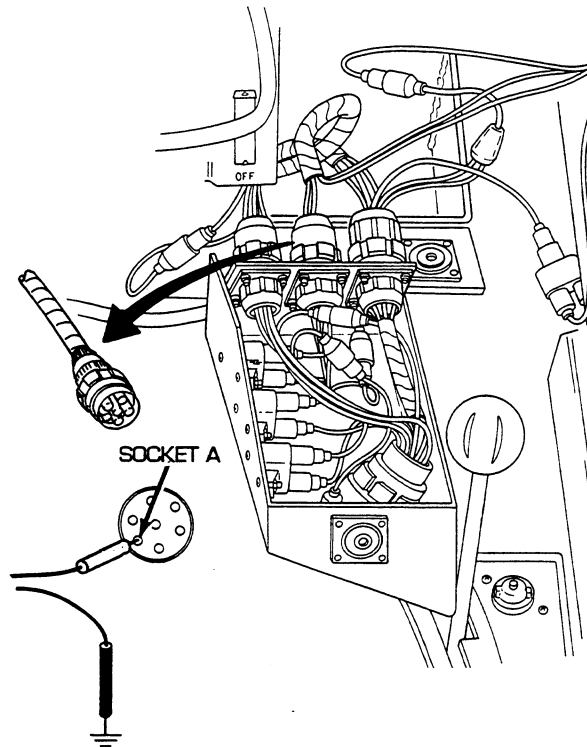

CORRECTIVE ACTION –Continued

4. Reconnect switch panel to neutral safety to bulkhead wiring harness to main switch panel. Disconnect wire 14 at Y-connector on switch panel side. Place red lead of multimeter in wire 14 and black lead to ground. Turn MASTER switch on, push START switch, and check for voltage. Turn MASTER switch OFF. If voltage is present, go to step 5. If voltage is not present, replace/repair wire 14 of switch panel to neutral safety to bulkhead wiring harness (see WP 0203 00).

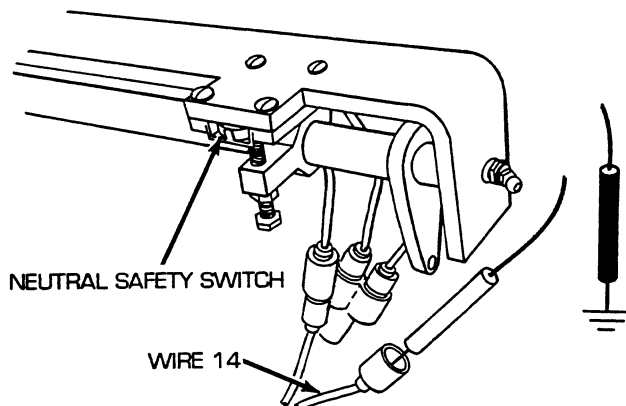

5. Reconnect wire 14 to Y-connector on switch panel side. Disconnect wire 14 from bulkhead side of neutral safety switch. Place red lead of multimeter in male connector of neutral safety switch and black lead to ground. Turn MASTER switch on, push START switch and check for voltage. Turn MASTER switch OFF. If voltage is present, go to step 6. If voltage is not present, ensure bolt (1) is making contact with neutral safety switch. If no contact is present adjust neutral safety switch (see WP 0163 00). If contact is present replace neutral safety switch (see WP 0163 00).

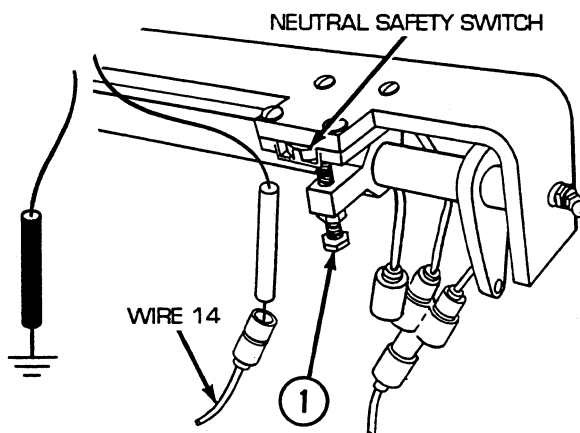

CORRECTIVE ACTION –Continued**WARNING**

Place transmission selector in P (park).

6. Reconnect wire 14 to connector on bulkhead side of neutral safety switch. Open air inlet doors (TM 9-2350-256-10). Disconnect bulkhead to engine wiring harness and starter relay wiring harness from bulkhead disconnect. Place red lead of multimeter on pin A of wire 14 and black lead to ground. Turn MASTER switch on, push START switch, and check for voltage. Turn MASTER switch OFF. If voltage is present, go to step 7. If voltage is not present, replace/repair wire 14 of switch panel to neutral safety to bulkhead wiring harness (see WP 0203 00).

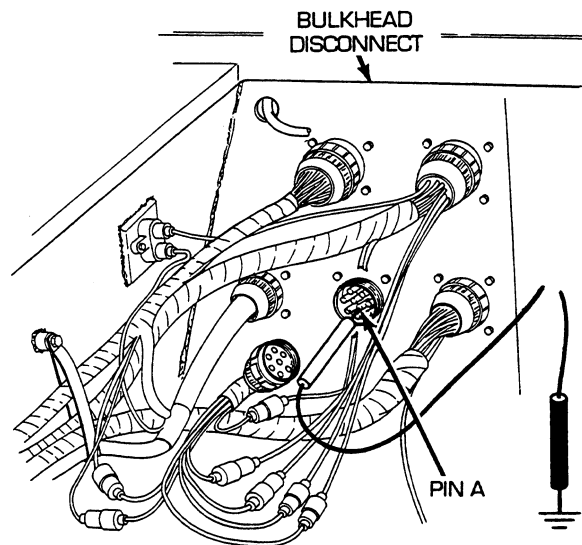

CORRECTIVE ACTION –Continued

7. Reconnect switch panel to neutral safety to bulkhead wiring harness at bulkhead disconnect. Disconnect wire 14 of bulkhead to engine wiring harness and starter relay wiring harness from connector near bulkhead disconnect. Place red lead of multimeter on male connector and black lead to ground. Turn MASTER switch on, push START switch, and check for voltage. Turn MASTER switch OFF. If voltage is present, go to step 8. If voltage is not present, replace/repair wire 14 of bulkhead to engine wiring harness and starter relay wiring harness (see WP 0221 00).

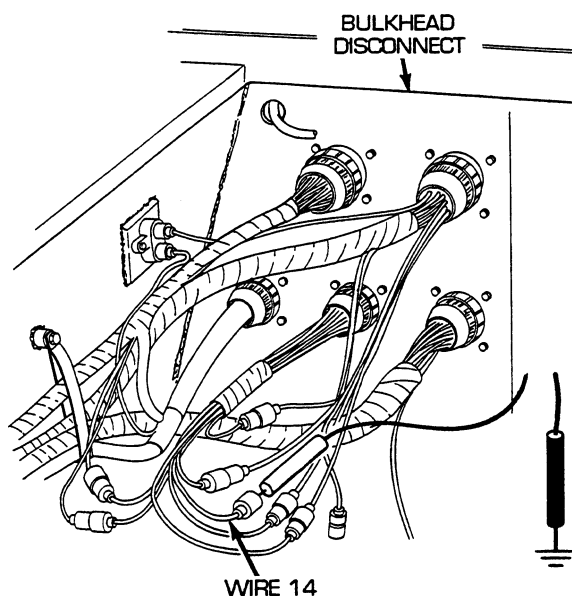

8. Reconnect wire 14 of bulkhead to engine wiring harness and starter relay wiring harness to connector near bulkhead disconnect. Remove engine deck (see WP 0336 00). Disconnect wire 14 of batteries to master relay, voltage regulators, slave receptacle, and engine disconnect wiring harness from connector near engine disconnect. Place red lead of multimeter on male connector of wire 14 and black lead to ground. Turn MASTER switch on, push START switch and check for voltage. Turn MASTER switch OFF. If voltage is not present, replace/repair wire 14 of bulkhead to engine disconnect wiring harness (see WP 0222 00 for dual voltage; 0223 00 for single voltage). If voltage is present, go to step 9.

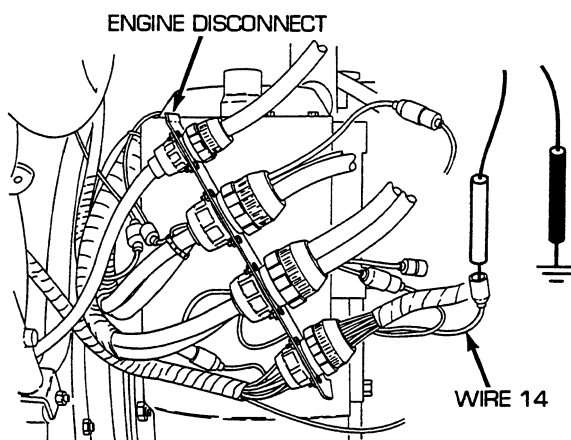

CORRECTIVE ACTION –Continued

9. Reconnect wire 14 of engine disconnect wiring harness to connector near engine disconnect. Remove engine deck (see WP 0336 00). Disconnect batteries to master relay, voltage regulators, slave receptacle, and engine disconnect wiring harness from engine disconnect. Place red lead of multimeter in socket C of wire 14 and black lead to ground. Turn MASTER switch on, push START switch, and check for voltage. Turn MASTER switch OFF. If voltage is present, go to step 10. If voltage is not present, replace/repair wire 14 of batteries to master relay, voltage regulators, slave receptacle, and engine disconnect wiring harness (see WP 0190 00 for dual voltage; 0191 00 for single voltage).

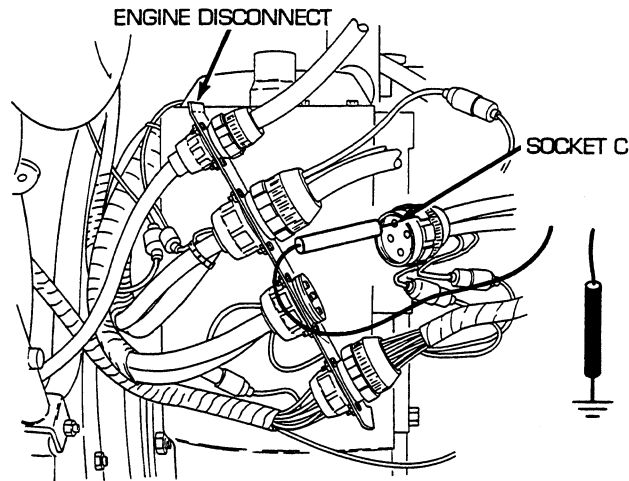

10. Remove powerplant and connect groundhop kit (see WP 0098 00 and 0099 00). Reconnect battery to master relay, voltage regulators, slave receptacle, and engine disconnect wiring harness to engine disconnect. Disconnect module starter wiring harness from low voltage protection module. Place red lead of multimeter in socket A of wire 14 and black lead to ground. Turn MASTER switch on, push START switch, and check for voltage. Turn MASTER switch OFF. If voltage is present, go to step 11. If voltage is not present, replace/repair wire 14 of module starter wiring harness (see WP 0189 00).

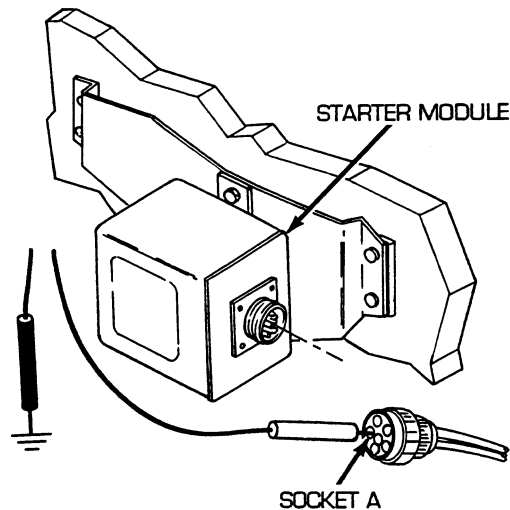

CORRECTIVE ACTION –Continued

11. Place red lead of multimeter in socket B of wire 74 and black lead to ground. If voltage is present, go to step 14. If voltage is not present, replace/repair wire 82/74 of module starter wiring harness (see WP 0189 00).

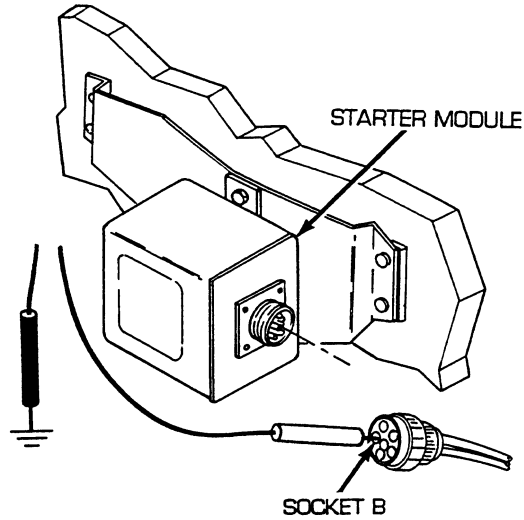

12. Reconnect wire 14 to START switch side of circuit breaker. Disconnect wire 10 from circuit breaker. Place red lead of multimeter in wire 10 and black lead to ground. Turn MASTER switch on and check for voltage. Turn MASTER switch OFF. If voltage is present, replace circuit breaker (see WP 0159 00). If voltage is not present, go to step 13.

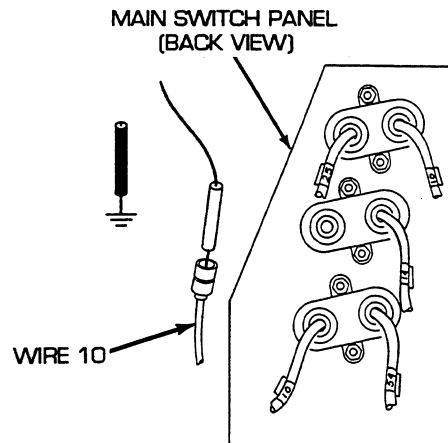

CORRECTIVE ACTION –Continued

13. Disconnect switch panel to gage panel and miscellaneous switches wiring harness from main switch panel. Place red lead of multimeter on pin M of wire 10 and black lead to ground. Turn MASTER switch on and check for voltage. Turn MASTER switch OFF. If voltage is present, repair/replace wire 10 of circuit breaker to main switch panel wiring harness. If voltage is not present, troubleshoot battery power circuit.

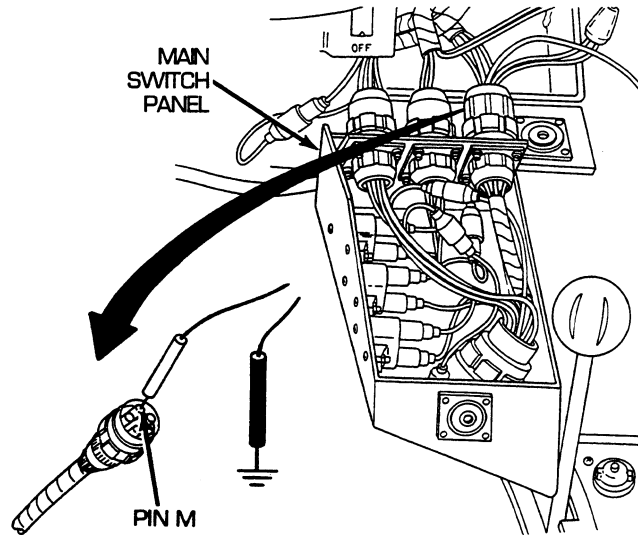

14. Check for voltage at wire 82 of starter solenoid. If voltage is present, replace starter motor (see WP 0152 00). If voltage is not present replace starter module (see WP 0189 00).

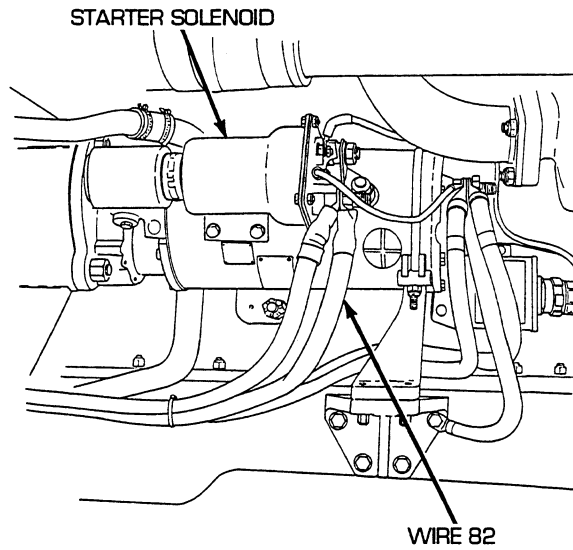

END OF WORK PACKAGE

UNIT MAINTENANCE
RECOVERY VEHICLE, FULL TRACKED: MEDIUM, M88A1
NSN 2350-00-122-6826, EIC AQA
ENGINE MANIFOLD PREHEATER SYSTEM TROUBLESHOOTING PROCEDURE

INITIAL SETUP:**Tools and Special Tools**

Tool kit, general mechanic's (item 59, WP 0490 00)

References

WP 0098 00
WP 0122 00
WP 0132 00
WP 0133 00
WP 0134 00
WP 0159 00
WP 0203 00
WP 0206 00

References (cont.)

WP 0207 00
WP 0208 00
WP 0218 00
WP 0219 00
WP 0221 00
WP 0222 00
WP 0223 00
WP 0231 00
WP 0336 00
TM 9-2350-256-10

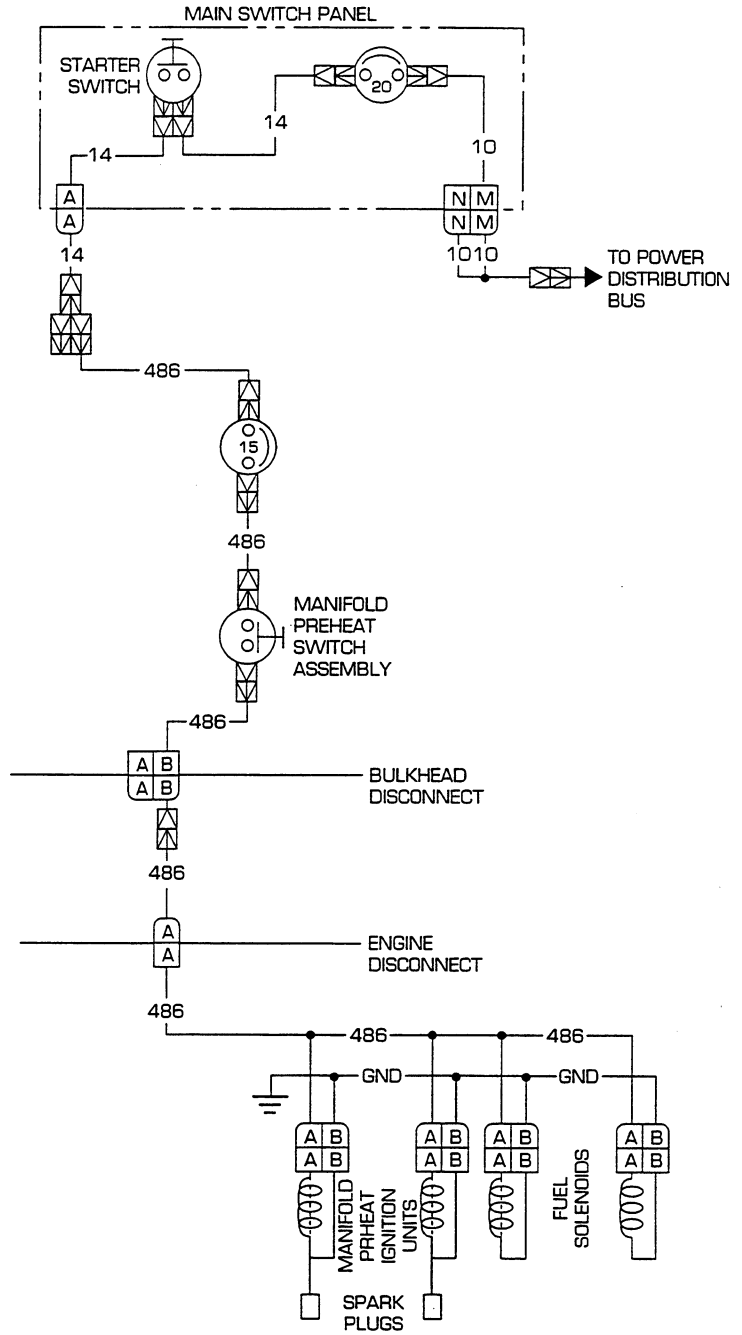
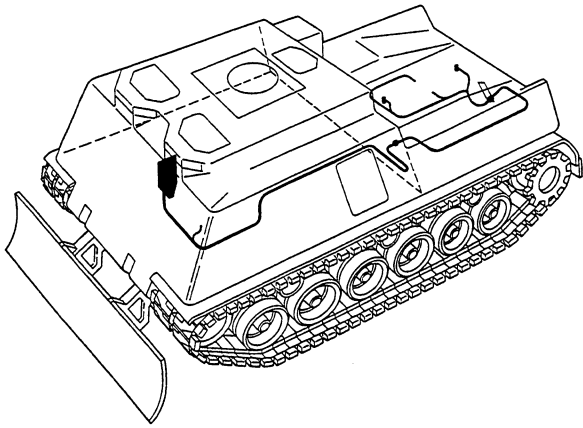

Troubleshooting Procedure

Engine Manifold Preheater System

Symptom

Engine manifold preheater system malfunctioning.

Malfunction

Manifold preheater fails to operate. Do steps 1 thru 19.

CORRECTIVE ACTION

WARNING

Remove all jewelry such as rings, dog tags, bracelets, etc. If jewelry contacts a metal surface a direct short may result in instant heating of tools, damage to equipment, and injury or death to personnel.

1. Remove three screws (1), three lockwashers (2), ground lead (3), flat washer (4), and release main switch panel (5) from mounting brackets. Disconnect switch panel to neutral safety to bulkhead wiring harness from main switch panel. Place red lead of multimeter in socket A of wire 14 and black lead to ground. Turn MASTER switch on, push START switch, and check for voltage. Turn MASTER switch OFF. If voltage is not present, go to step 15. If voltage is present, go to step 2.

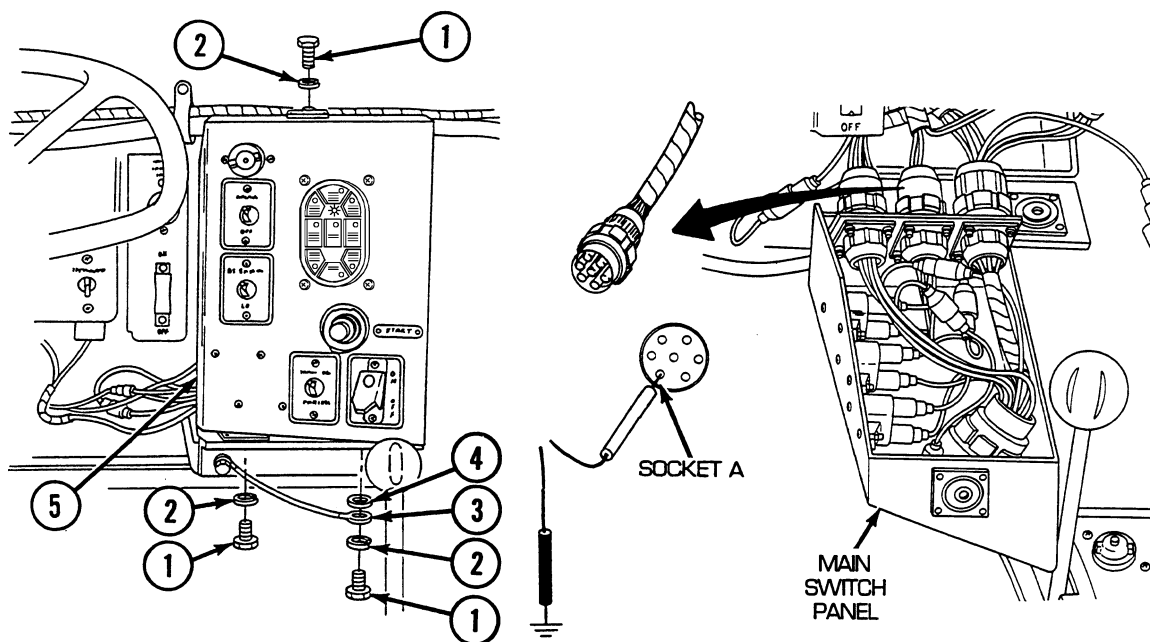

CORRECTIVE ACTION –Continued

2. Reconnect switch panel to neutral safety to bulkhead wiring harness to main switch panel. Install main switch panel (5), flat washer (4), ground lead (3), three lockwashers (2), and three screws (1) to mounting bracket. Disconnect wire 486 at Y-connector rear main switch panel on manifold preheat switch side. Place red lead of multimeter on male connector of wire 486 and black lead to ground. Turn MASTER switch on, push START switch, and check for voltage. Turn MASTER switch OFF. If voltage is present, go to step 3. If voltage is not present, repair/replace wire 14 of switch panel to neutral safety to bulkhead wiring harness (see WP 0203 00).

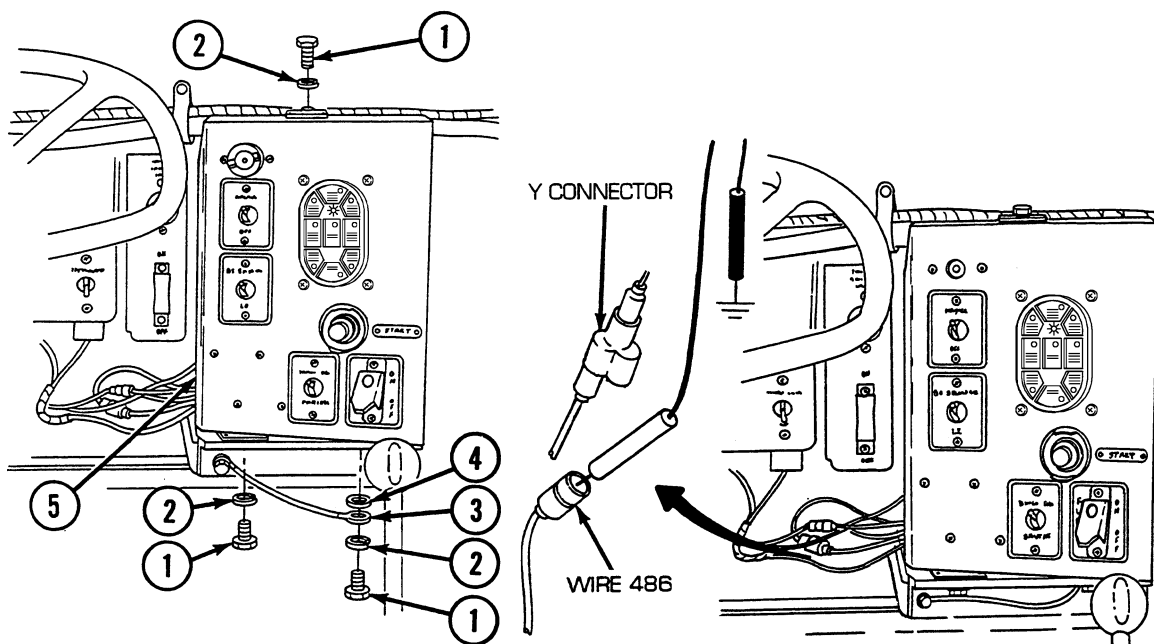

3. Reconnect wire 486 to Y-connector on manifold preheat switch side. Disconnect wire 486 from switch panel side of 15 A circuit breaker. Place red lead of multimeter on female connector of wire 486 and black lead to ground. Turn MASTER switch on, push START switch, and check for voltage. Turn MASTER switch OFF. If voltage is present, go to step 4. If voltage is not present, repair/replace wire 486 or air cleaner circuit breaker lead assembly (see WP 0231 00).

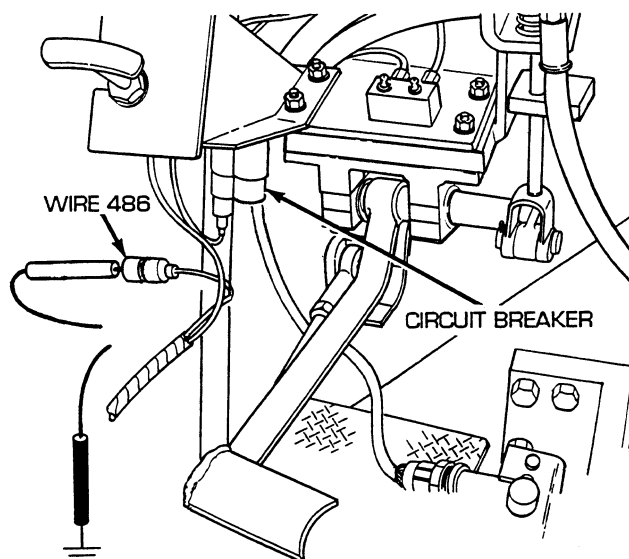

CORRECTIVE ACTION –Continued

4. Reconnect wire 486 to switch panel side of 15 A circuit breaker. Disconnect wire 486 from manifold preheater switch side of 15 A circuit breaker. Place red lead of multimeter on circuit breaker terminal and black lead to ground. Turn MASTER switch on, push START switch, and check for voltage. Turn MASTER switch OFF. If voltage is present, go to step 5. If voltage is not present, replace 15 A circuit breaker.

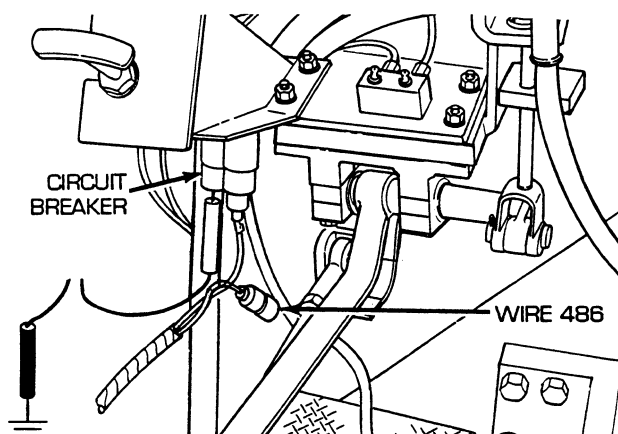

5. Reconnect wire 486 to manifold preheater switch side of 15 A circuit breaker. Disconnect wire 486 from circuit breaker side of manifold preheater switch. Place red lead of multimeter in wire 486 and black lead to ground. Turn MASTER switch on, push START switch, and check for voltage. Turn MASTER switch OFF. If voltage is present, go to step 6. If voltage is not present, repair/replace wire 486 of switch panel to neutral safety to bulkhead wiring harness from circuit breaker to manifold preheat switch assembly (see WP 0203 00).

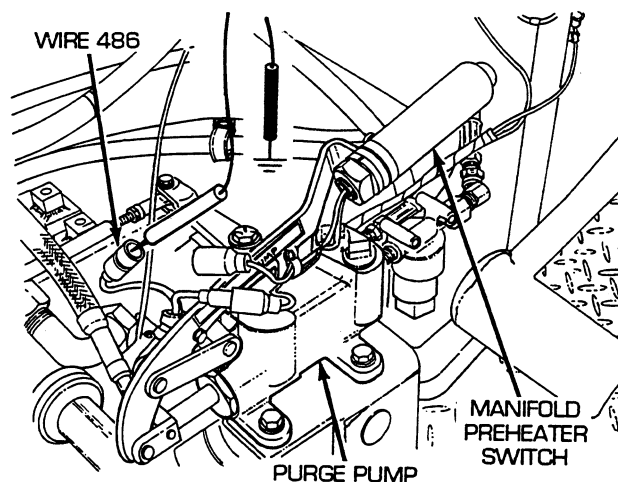

CORRECTIVE ACTION –Continued

6. Reconnect wire 486 to circuit breaker side of manifold preheat switch. Disconnect wire 486 from bulkhead side of manifold preheat switch. Place red lead of multimeter on switch terminal and black lead to ground. Turn MASTER switch on, push START and manifold preheat switches, and check for voltage. Turn MASTER switch OFF. If voltage is present, go to step 7. If voltage is not present, replace manifold preheat switch assembly (see WP 0122 00).

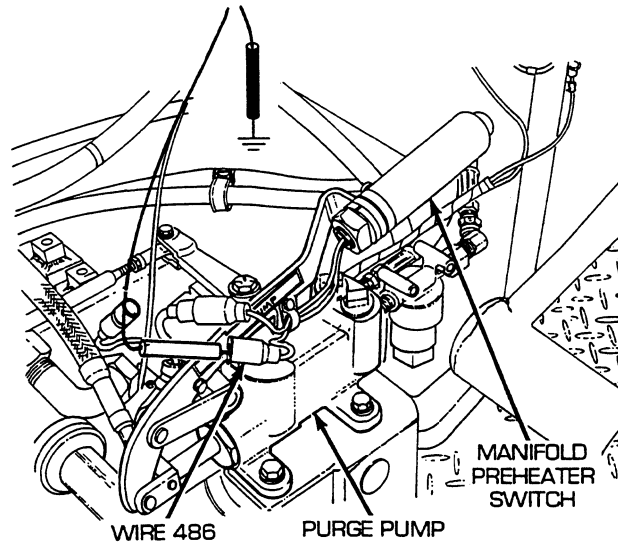

7. Reconnect switch panel to neutral safety switch to bulkhead wiring harness to main switch panel. Open air inlet doors (TM 9-2350-256-10). Disconnect bulkhead to engine harness and starter relay wiring harness from bulkhead disconnect. Place red lead of multimeter on pin B of wire 486 and black lead to ground. Turn MASTER switch on, push START and manifold preheat switches, and check for voltage. Turn MASTER and manifold preheat switches OFF. If voltage is present, go to step 8. If voltage is not present, replace/repair wire 486 of switch panel to neutral safety to bulkhead wiring harness.

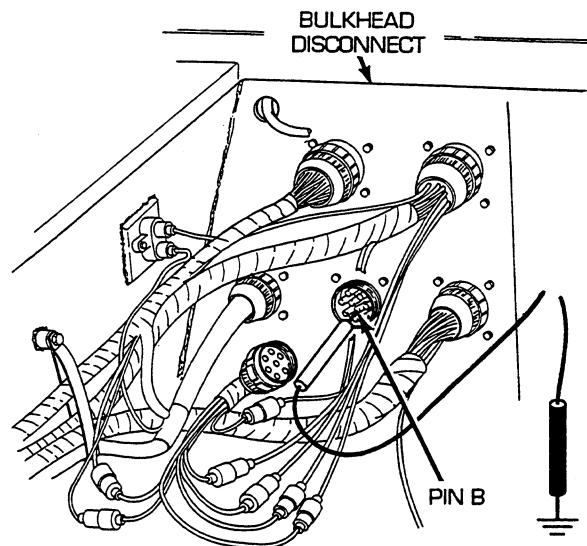

CORRECTIVE ACTION –Continued

8. Reconnect bulkhead to engine wiring harness and starter relay wiring harness to bulkhead disconnect. Disconnect wire 486 from connector near bulkhead disconnect. Place red lead of multimeter in female connector and black lead to ground. Turn MASTER switch on, push START and manifold preheat switches, and check for voltage. Turn MASTER switch OFF. If voltage is present, go to step 9. If voltage is not present, repair/replace wire 486 of bulkhead to engine wiring harness and starter relay wiring harness from female connector to bulkhead disconnect (see WP 0221 00).

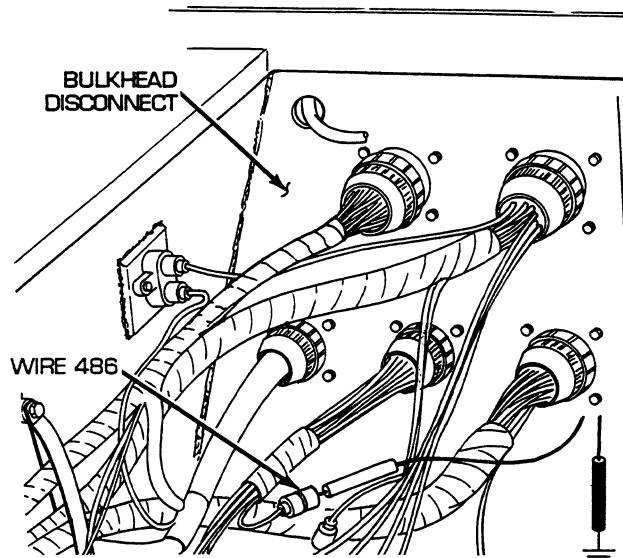

9. Remove engine deck (see WP 0336 00). Reconnect wire 486 at connector near bulkhead disconnect. Disconnect bulkhead to engine bracket and rear fuel tank transmitter wiring harness from engine disconnect. Place red lead of multimeter in socket A of wire 486 and black lead to ground. Turn MASTER switch ON, push START and manifold preheat switches, and check for voltage. Turn MASTER, START and manifold preheat switches OFF. If voltage is present, go to step 10. If voltage is not present repair/replace wire 486 of bulkhead to engine bracket and rear fuel tank transmitter wiring harness (see WP 0222 00 for dual voltage; 0223 00 for single voltage).

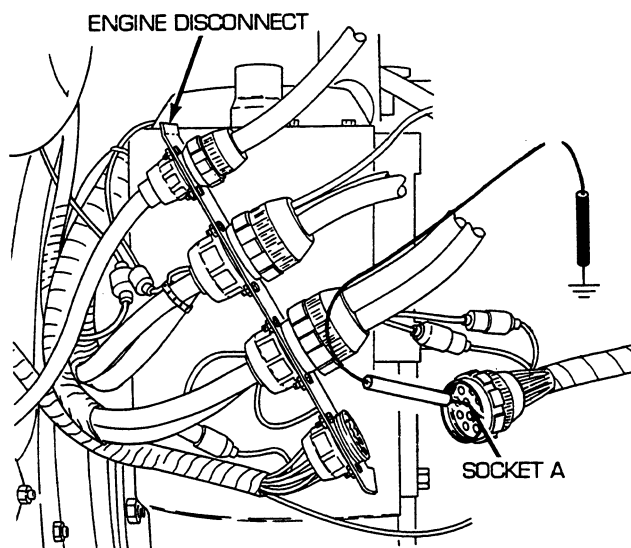

CORRECTIVE ACTION –Continued**NOTE**

Steps 10 through 14 are the same for both left and right preheaters and fuel solenoids. Perform 10 through 14 as necessary for each side.

10. Remove powerplant (see WP 0098 00). Reconnect bulkhead to engine bracket and rear fuel tank transmitter wiring harness to engine disconnect. Disconnect engine wiring harness from manifold preheater ignition unit. Place red lead of multimeter in socket A of wire 486 and black lead to ground. Turn MASTER switch on, push START and manifold preheat switches, and check for voltage. Turn MASTER, START, and manifold preheat switches OFF. If voltage is present, go to step 11. If voltage is not present, repair/replace wire 486 of engine wiring (see WP 0207 00 for dual voltage; 0208 00 for single voltage).

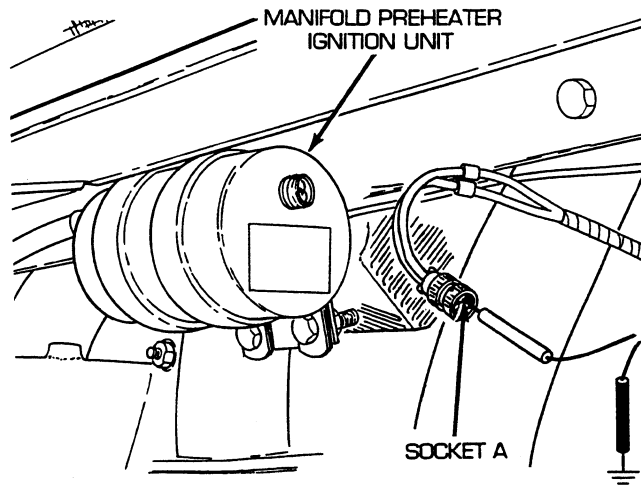

11. Place red lead of multimeter in socket B of ground wire and black lead to ground. Check for continuity. If continuity is present, go to step 12. If continuity is not present, repair/replace ground wire of engine wiring harness (see WP 0207 00 for dual voltage; 0208 00 for single voltage).

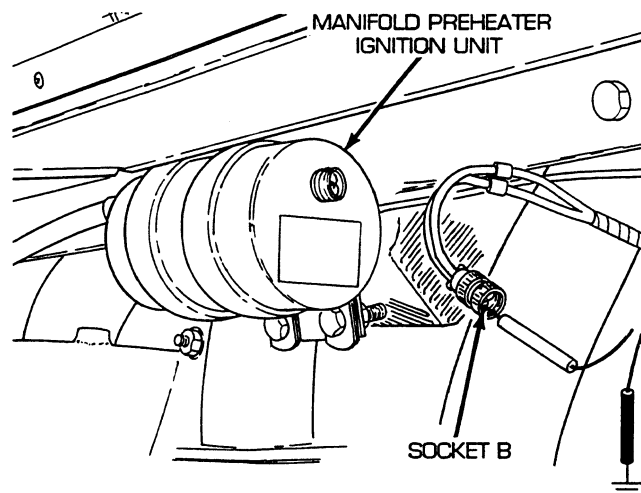

CORRECTIVE ACTION –Continued

12. Reconnect engine wiring harness to manifold preheater ignition unit. Disconnect engine wiring harness from fuel solenoid. Place red lead of multimeter in socket A of wire 486 and black lead to ground. Turn MASTER switch on, push START and manifold preheat switches, and check for voltage. Turn MASTER switch OFF. If voltage is present, go to step 13. If voltage is not present, repair/replace wire 486 of engine wiring harness (see WP 0207 00 for dual voltage; 0208 00 for single voltage).

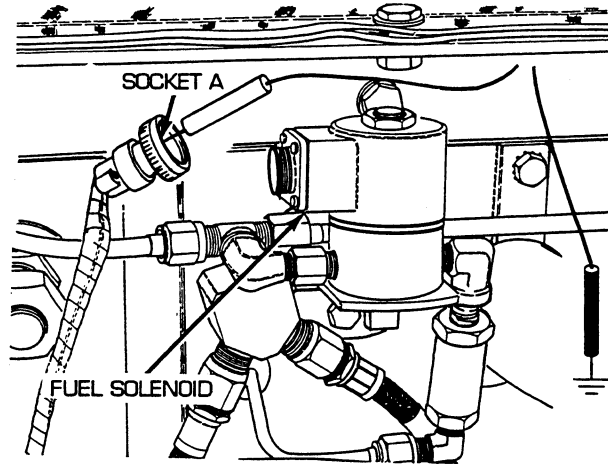

13. Place red lead of multimeter on pin B of fuel solenoid and black lead to pin A. Check for continuity. If continuity is present, go to step 14. If continuity is not present, replace fuel solenoid (see WP 0133 00).

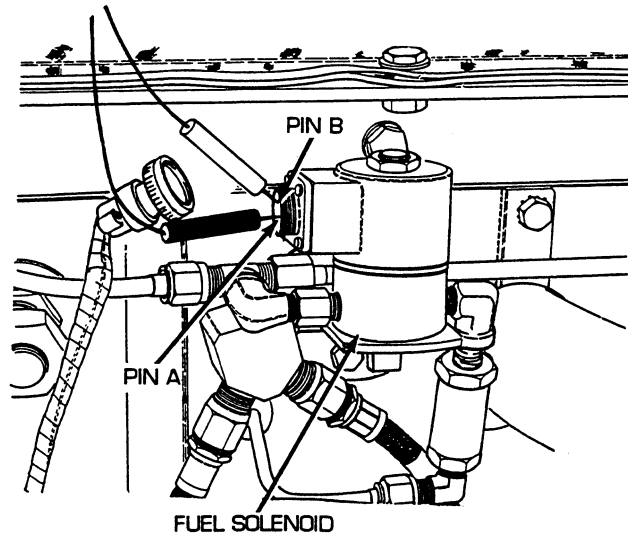

CORRECTIVE ACTION –Continued

14. Reconnect engine wiring harness to fuel solenoid. Disconnect lead from spark plug. Hold lead close to engine and turn MASTER switch on, push START and manifold preheat switches, and check for spark. Turn MASTER switch OFF. If spark is present, replace spark plug (see WP 0134 00). If spark is not present, replace manifold preheater ignition unit (see WP 0132 00).

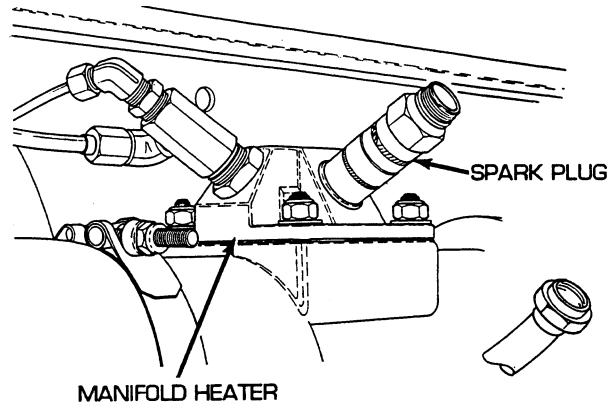

15. Reconnect switch panel to neutral safety switch to bulkhead harness to main switch panel. Disconnect switch panel to gage panel and miscellaneous switches wiring harness from main switch panel. Place red lead of multimeter on pin 13 of wire 10 and black lead to ground. Turn MASTER switch on push START switch, and check for voltage. Turn MASTER switch OFF. If voltage is present, go to step 16. If voltage is not present, troubleshoot battery circuit.

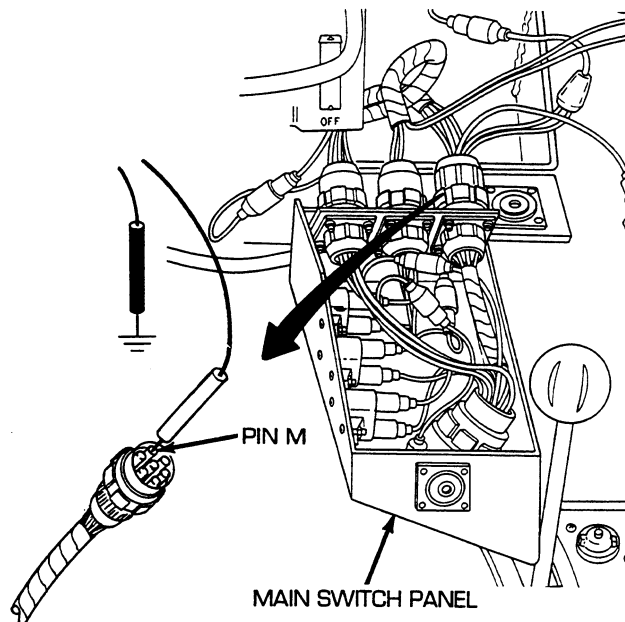

CORRECTIVE ACTION –Continued

16. Place a jumper wire from bracket to hull to ground the panel. Reconnect switch panel and miscellaneous switches wiring harness to main switch panel. Disconnect wire 14 from START switch side of 20 A circuit breaker. Place red lead of multimeter on terminal of 20 A circuit breaker and black lead to ground. Turn MASTER switch on and check for voltage. Turn MASTER switch OFF. If voltage is present, go to step 18. If voltage is not present, go to step 17.

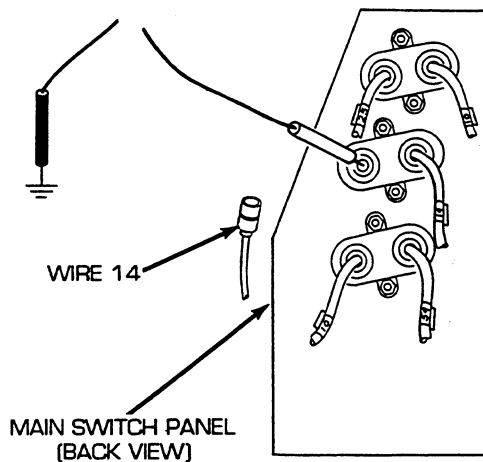

17. Reconnect wire 14 to START switch side of 20 A circuit breaker. Disconnect wire 10 from 20 A circuit breaker. Place red lead of multimeter in wire 10 and black lead to ground. Turn MASTER switch on and check for voltage. Turn MASTER switch OFF. If voltage is present, replace circuit breaker (see WP 0159 00). If voltage is not present, repair/replace wire 10 of main lighting and B.O. selector switch wiring harness (see WP 0218 00).

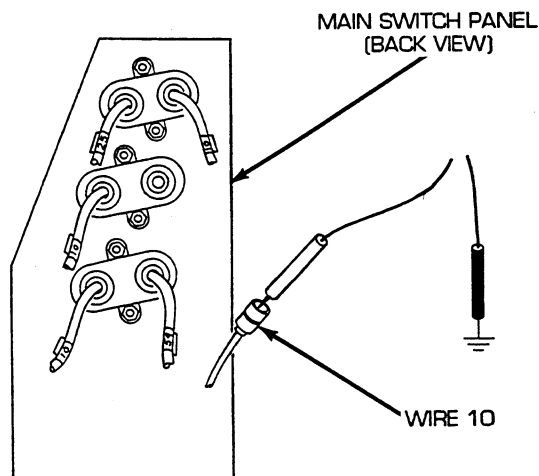

CORRECTIVE ACTION –Continued

18. Reconnect wire 14 to 20 A circuit breaker. Disconnect connector from START switch. Place red lead of multimeter in wire 14 from circuit breaker and black lead to ground. Turn MASTER switch on and check for voltage. Turn MASTER switch OFF. If voltage is present, go to step 19. If voltage is not present, repair/replace wire 14 of main lighting and B.O. selector switch wiring harness (see WP 0219 00).

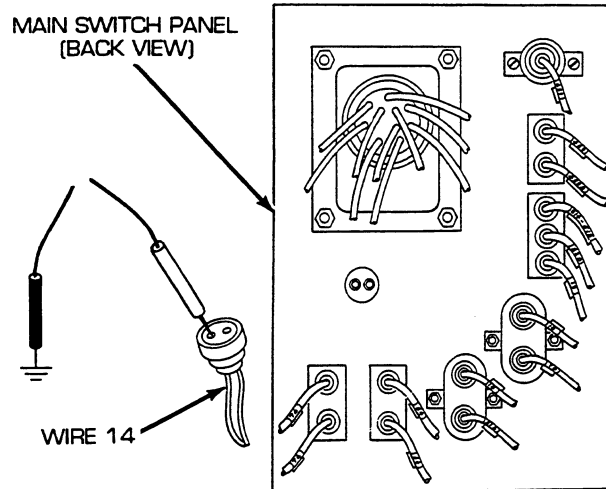

19. Place jumper in wire 14 from circuit breaker to START switch input terminal. Place red lead of multimeter on START switch output terminal and black lead to ground. Turn MASTER switch on, push START switch, and check for voltage. Turn MASTER and START switches OFF. If voltage is present, repair/replace wire 14 of starter switch wiring harness (see WP 0206 00). If voltage is not present, replace START switch (see WP 0159 00).

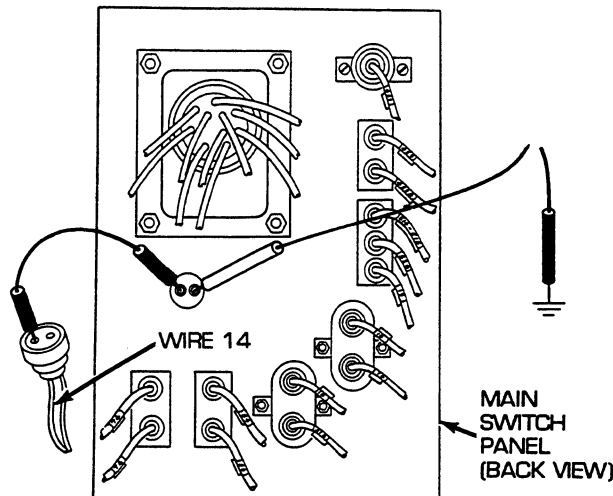

END OF WORK PACKAGE

UNIT MAINTENANCE
RECOVERY VEHICLE, FULL TRACKED: MEDIUM, M88A1
NSN 2350-00-122-6826, EIC AQA

ENGINE FUEL SHUTOFF SOLENOID TROUBLESHOOTING PROCEDURE

INITIAL SETUP:

Tools and Special Tools

Tool kit, general mechanic's (item 59, WP 0490 00)

References

- WP 0130 00
- WP 0159 00
- WP 0165 00
- WP 0198 00
- WP 0203 00
- WP 0206 00

References (cont.)

- WP 0207 00
- WP 0208 00
- WP 0218 00
- WP 0221 00
- WP 0222 00
- WP 0223 00
- WP 0336 00
- TM 9-2350-256-10

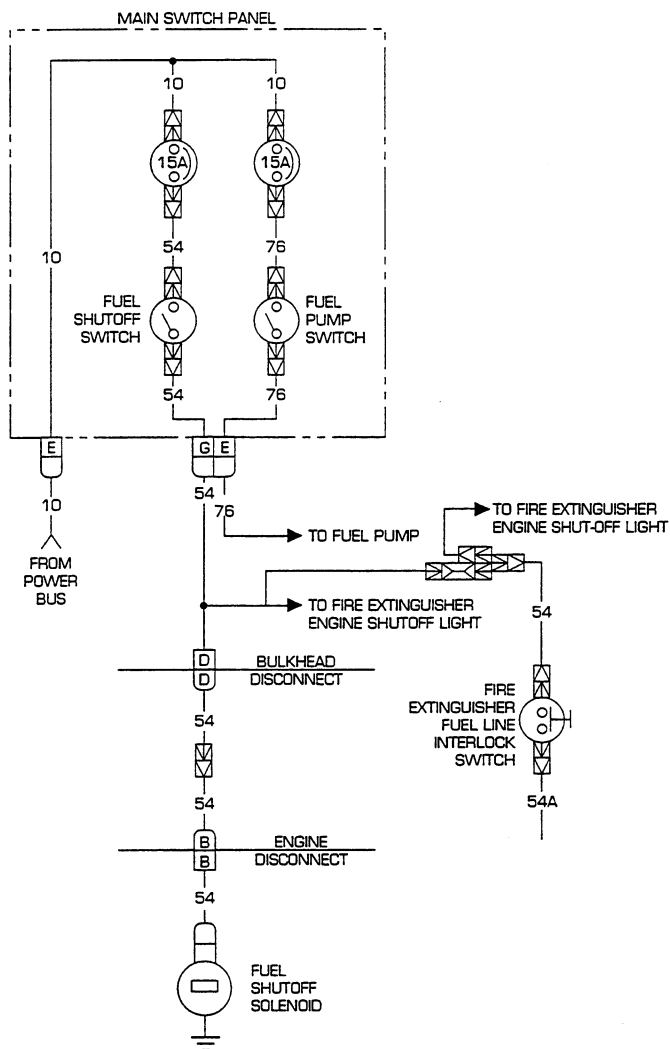
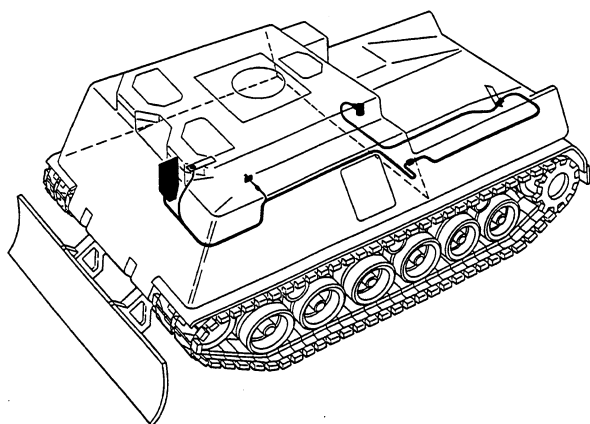

Troubleshooting Procedure

Engine Fuel Shutoff Solenoid

Symptom

Engine fuel shutoff solenoid malfunctioning.

Malfunction

Engine cranks but fails to start. Do steps 1 thru 11.

CORRECTIVE ACTION

WARNING

Remove all jewelry such as rings, dog tags, bracelets, etc. If jewelry contacts a metal surface a direct short may result in instant heating of tools, damage to equipment, and injury or death to personnel.

1. Remove three screws (1), three lockwashers (2), ground lead (3), flat washer (4), and release main switch panel (5) from mounting brackets. Disconnect switch panel to neutral safety to bulkhead wiring harness from main switch panel. Place red lead of multimeter in socket G of wire 54 and black lead to ground. Turn MASTER and ENGINE FUEL SHUTOFF switches on and check for voltage. Place red lead in socket E of wire 54 and black lead to ground and check for voltage. Turn MASTER and ENGINE FUEL SHUTOFF switches off. If voltage is present at pins G and E, go to step 2. If voltage is not present at pin 2, go to step 8. If voltage is not present at pin E, go to step 11.

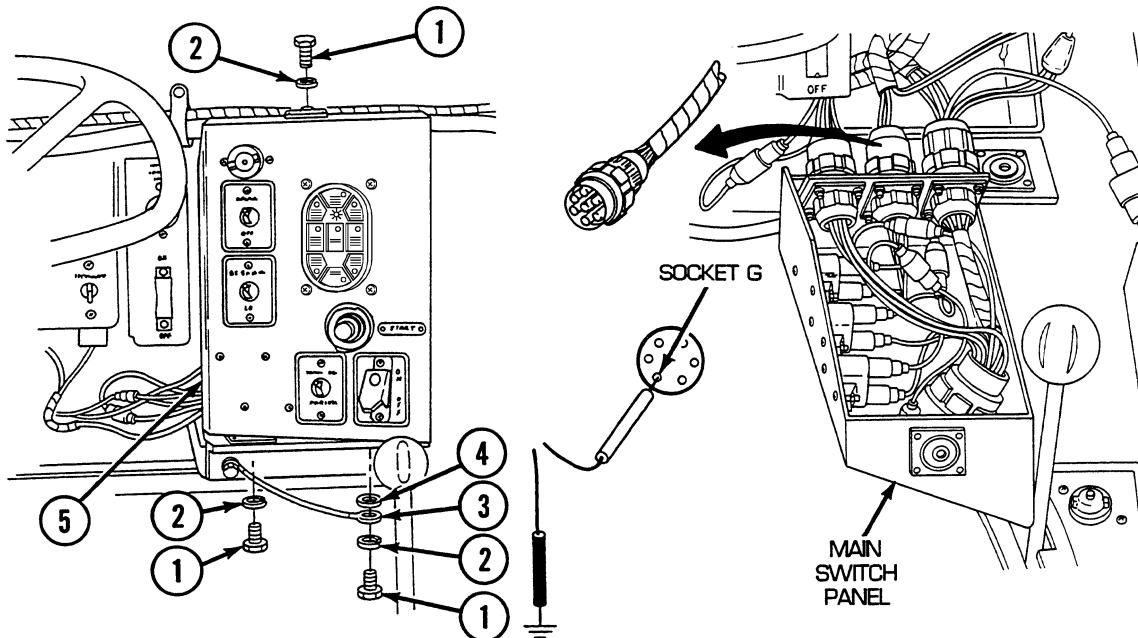

CORRECTIVE ACTION –Continued

2. Disconnect wire 54A of switch panel to head lamps and bulkhead wiring harness from fire extinguisher interlock switch. Place red lead of multimeter on wire 54A and black lead to ground. Turn MASTER switch on, and check for voltage. Turn MASTER switch OFF. If voltage is present, go to step 3. If voltage is not present, replace/repair wire 54 of switch panel to headlamps and bulkhead wiring harness.

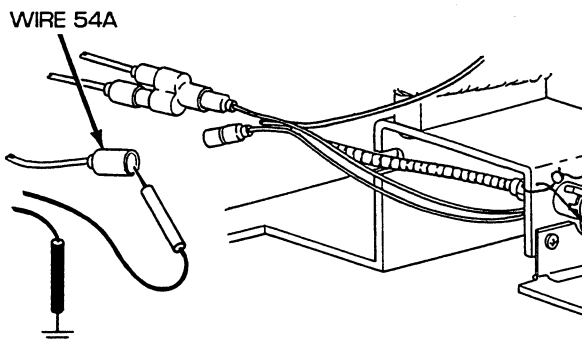

3. Reconnect wire 54A of switch panel to head lamps and bulkhead wiring harness to fire extinguisher interlock switch. Disconnect wire 54A on output side of fire extinguisher interlock switch from connector. Place red lead of multimeter in wire 54A and black lead to ground. Turn MASTER switch on, release fire extinguisher interlock switch, and check for voltage. Turn MASTER and fire extinguisher interlock switches OFF. If voltage is present, reconnect wire 54A on output side of fire extinguisher interlock switch to connector and, go to step 4. If voltage is not present, repair/replace fire extinguisher interlock switch assembly (see WP 0165 00).

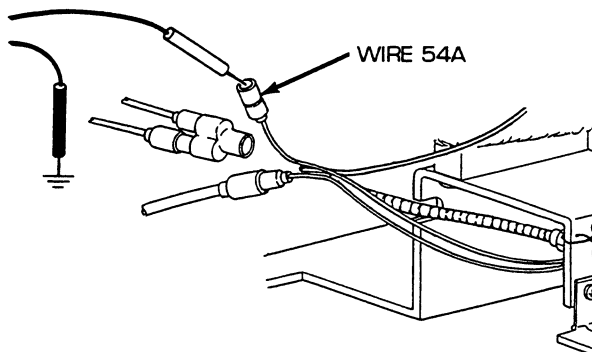

CORRECTIVE ACTION –Continued

4. Reconnect switch panel to neutral safety to bulkhead wiring harness to main switch panel. Install main switch panel (5), flat washer (4), ground lead (3), three lockwashers (2), and three screws (1) to mounting brackets. Open air inlet doors (TM 9-2350-256-10). Disconnect bulkhead to engine wiring harness and starter relay wiring harness from bulkhead. Place red lead of multimeter on pin D of wire 54 and black lead to ground. Turn MASTER and ENGINE FUEL SHUTOFF switches on, and check for voltage. Turn MASTER and ENGINE FUEL SHUTOFF switches OFF. If voltage is present, go to step 5. If voltage is not present, repair/replace wire 54 of switch panel to neutral safety to bulkhead wiring harness (see WP 0203 00).

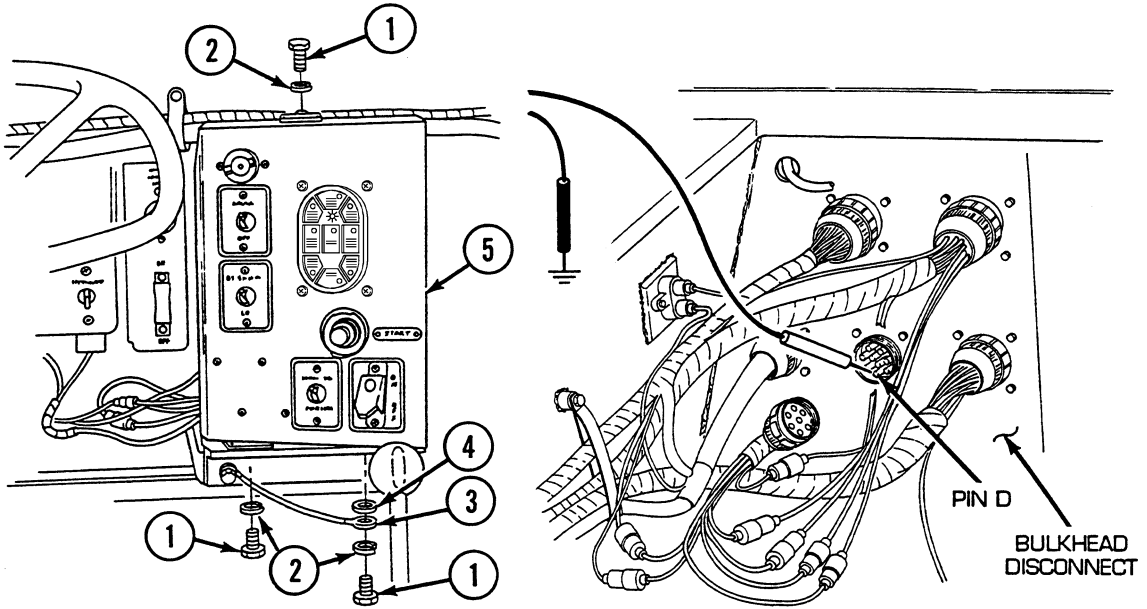

CORRECTIVE ACTION –Continued

5. Reconnect bulkhead to engine wiring harness and starter relay wiring harness to bulkhead. Remove engine deck (see WP 0336 00). Disconnect bulkhead to engine bracket and rear fuel tank transmitter wiring harness from engine disconnect. Place red lead of multimeter in socket B of wire 54 and black lead to ground. Turn MASTER and ENGINE FUEL SHUTOFF switches on and check for voltage. Turn MASTER and ENGINE FUEL SHUTOFF switches OFF. If voltage is present, repair/replace wire 54 of engine wiring harness (see WP 0207 00 for dual voltage; 0208 00 for single voltage). If voltage is not present, go to step 7.

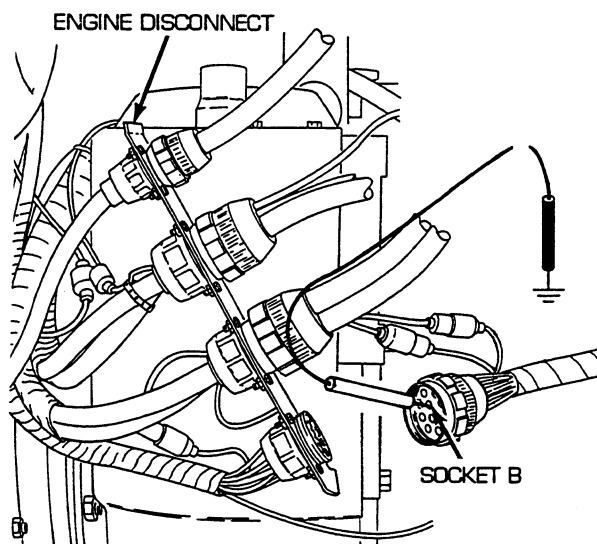

6. Disconnect wire 54 from fuel shutoff solenoid. Place red lead of multimeter in wire 54 and black lead to ground. Turn MASTER and ENGINE FUEL SHUTOFF switches on and check for voltage. Turn MASTER and ENGINE FUEL SHUTOFF switches OFF. If voltage is present, replace fuel shutoff solenoid (see WP 0130 00). If voltage is not present, go to step 7.

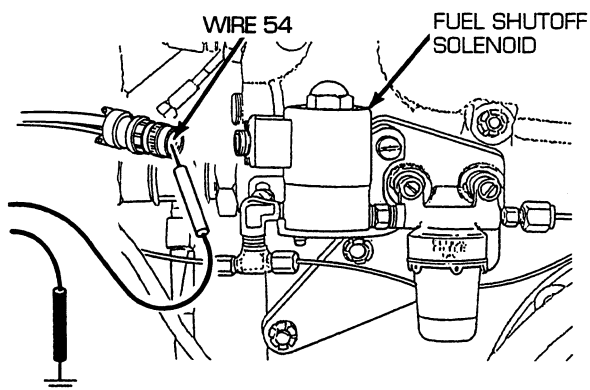

CORRECTIVE ACTION –Continued

7. Reconnect bulkhead to engine bracket and rear fuel tank transmitter wiring harness to engine disconnect. Disconnect wire 54 of bulkhead to engine wiring harness and starter relay wiring harness from bulkhead to engine bracket and rear fuel tank transmitter wiring harness. Place red lead of multimeter on male connector of wire 54 and black lead to ground. Turn MASTER and ENGINE FUEL SHUTOFF switches on and check for voltage. Turn MASTER and ENGINE FUEL SHUTOFF switches OFF. If voltage is present, repair/replace wire 54 of bulkhead to engine bracket and rear fuel tank transmitter wiring harness (see WP 0222 00 for dual voltage; 0223 00 for single voltage). If voltage is not present, repair/replace wire 54 of bulkhead to engine wiring harness and starter relay wiring harness (see WP 0221 00).

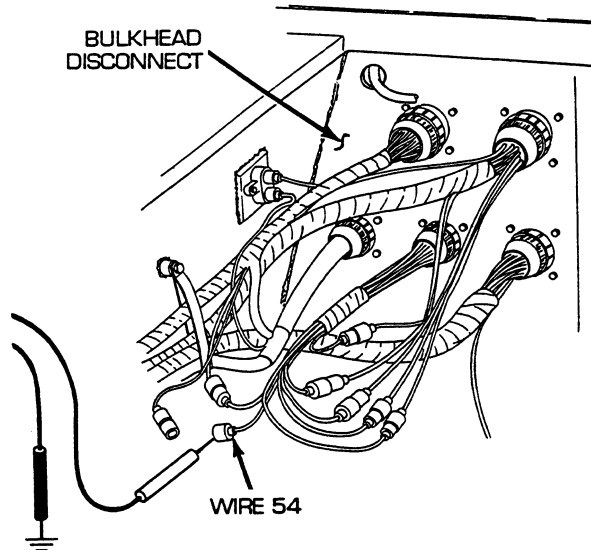

8. Reconnect switch panel to neutral safety to bulkhead wiring harness to main switch panel. Disconnect wire 54 from ENGINE FUEL SHUTOFF switch side of circuit breaker. Place red lead of multimeter on terminal of circuit breaker and black lead to ground. Turn MASTER switch on, and check for voltage. Turn MASTER switch OFF. If voltage is present, go to step 10. If voltage is not present, go to step 9.

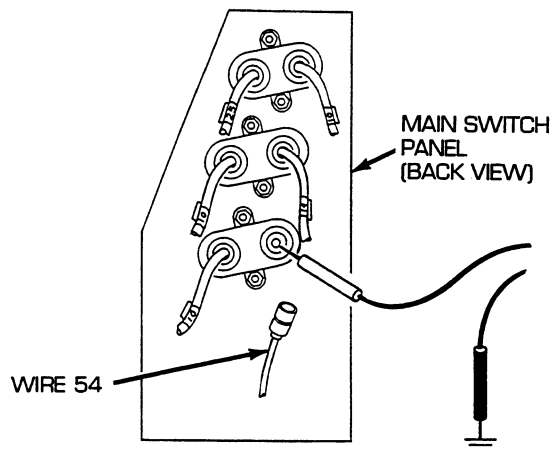

CORRECTIVE ACTION –Continued

9. Reconnect wire 54 to ENGINE FUEL SHUTOFF switch side of 15 A circuit breaker. Disconnect wire 10 from 15 A circuit breaker. Place red lead of multimeter in wire 10 and black lead to ground. Turn MASTER switch on and check for voltage. Turn MASTER switch OFF. If voltage is present, replace circuit breaker (see WP 0159 00). If voltage is not present, repair/replace wire 10 of main lighting and B.O. selector switch wiring harness (see WP 0218 00).

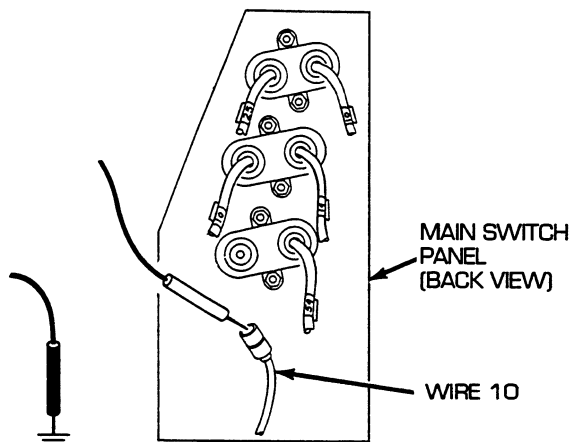

10. Reconnect wire 54 to ENGINE FUEL SHUTOFF switch side of 15 A circuit breaker. Disconnect wire 54 from circuit breaker side of ENGINE FUEL SHUTOFF switch. Place red lead of multimeter on wire 54 and black lead to ground. Turn MASTER switch on, and check for voltage. Turn MASTER switch OFF. If voltage is present, go to step 11. If voltage is not present, repair/replace fuel shutoff switch panel lead assembly (see WP 0198 00).

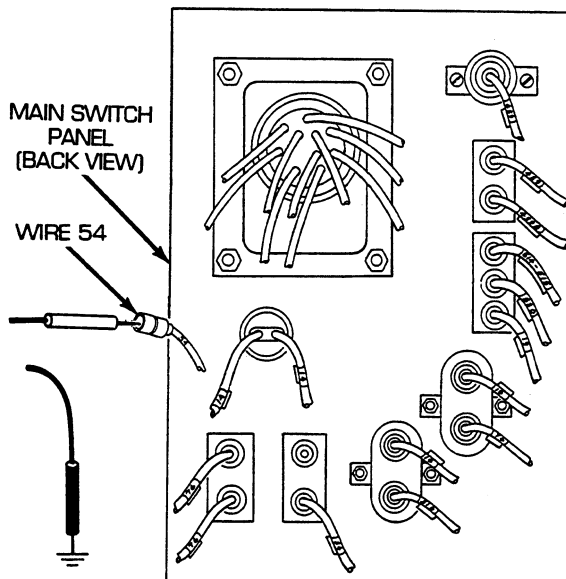

CORRECTIVE ACTION –Continued

11. Reconnect wire 54 to circuit breaker side of ENGINE FUEL SHUTOFF switch. Disconnect wire 54 from panel side of ENGINE FUEL SHUTOFF switch. Place red lead of multimeter on terminal of ENGINE FUEL SHUTOFF switch and black lead to ground. Turn MASTER and ENGINE FUEL SHUTOFF switches on and check for voltage. Turn MASTER and ENGINE FUEL SHUTOFF switches OFF. If voltage is present, repair/replace wire 54 of starter switch wiring harness (see WP 0206 00). If voltage is not present, replace ENGINE FUEL SHUTOFF switch (see WP 0159 00).

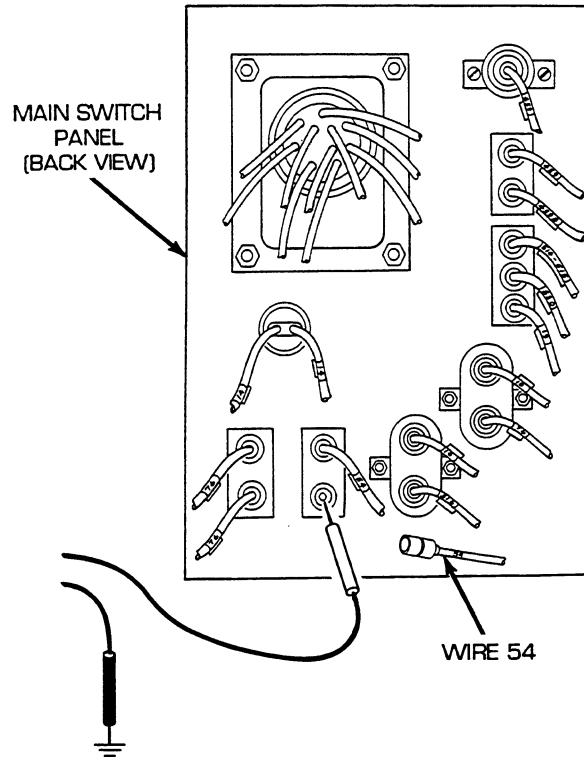
**END OF WORK PACKAGE**

UNIT MAINTENANCE
RECOVERY VEHICLE, FULL TRACKED: MEDIUM, M88A1
NSN 2350-00-122-6826, EIC AQA

FIRE EXTINGUISHER ENGINE SHUTOFF LIGHT TROUBLESHOOTING PROCEDURE

INITIAL SETUP:

Tools and Special Tools

Tool kit, general mechanic's (item 59, WP 0490 00)

References

WP 0160 00
WP 0197 00
WP 0238 00

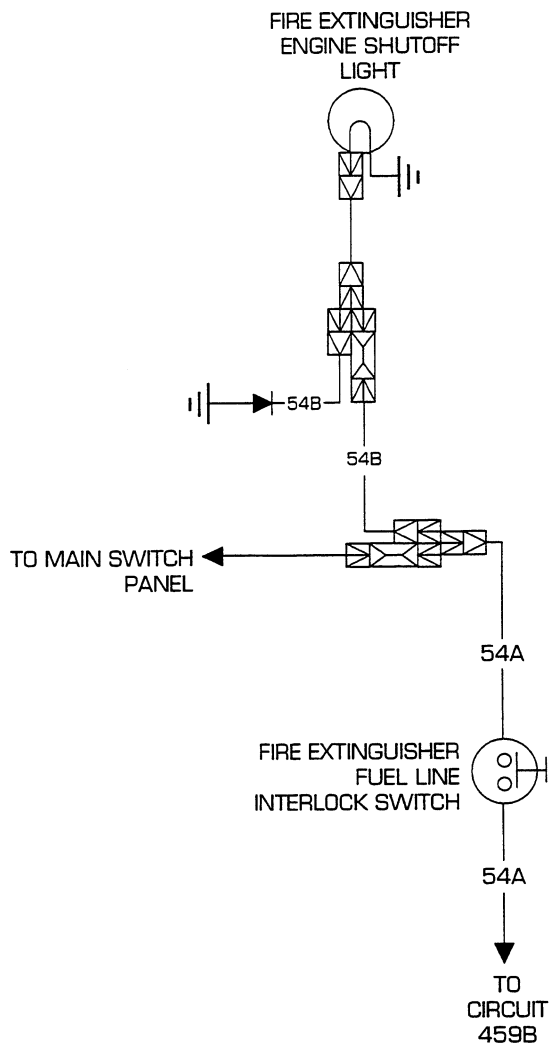
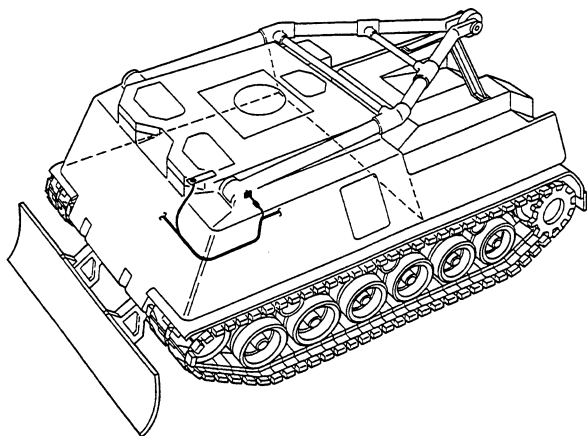

Troubleshooting Procedure

Fire Extinguisher Engine Shutoff Light

Symptom

Fire extinguisher engine shutoff light malfunctioning.

Malfunction

Fire extinguisher engine shutoff light fails to operate while fuel shutoff switch operates normally. Do steps 1 thru 5.

CORRECTIVE ACTION

WARNING

Remove all jewelry such as rings, dog tags, bracelets, etc. If jewelry contacts a metal surface a direct short may result in instant heating of tools, damage to equipment, and injury or death to personnel.

1. Disconnect wire 54B of flasher system panel wiring harness from connector at fire extinguisher interlock switch. Place red lead of multimeter on pin of connector and black lead to ground. Turn MASTER and FUEL SHUTOFF switches on and check for voltage. Turn MASTER and FUEL SHUTOFF switches OFF. If voltage is present, go to step 2. If voltage is not present, go to step 5.

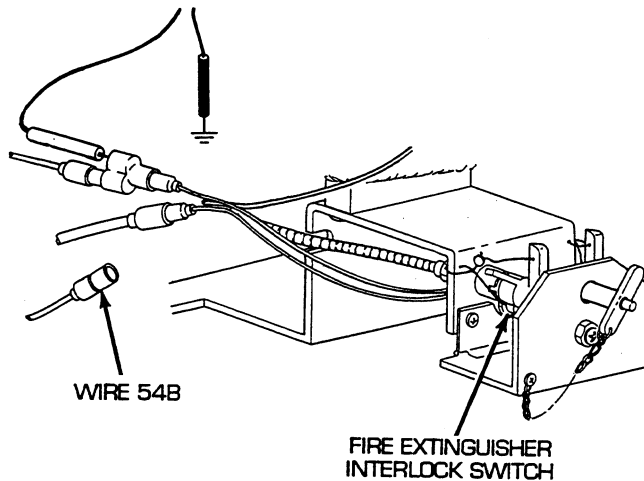

CORRECTIVE ACTION –Continued

2. Reconnect wire 54B of flasher system panel wiring harness to connector at fire extinguisher interlock switch. Disconnect diode lead assembly connector from fire extinguisher engine shutoff light. Place red lead of multimeter in connector of fire extinguisher engine shutoff light and black lead to ground. Turn MASTER and FUEL SHUTOFF switches ON and check for voltage. Turn MASTER and FUEL SHUTOFF switches OFF. If voltage is present, replace fire extinguisher engine shutoff light (see WP 0160 00). If voltage is not present, go to step 3.

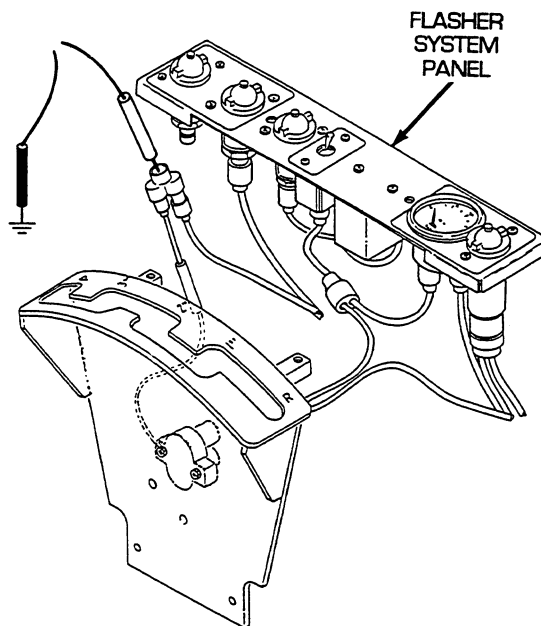

3. Reconnect diode lead assembly connector to fire extinguisher engine shutoff light. Disconnect wire 54B of flasher system panel wiring harness from diode lead assembly connector. Place red lead of multimeter on wire 54B and black lead to ground. Turn MASTER and FUEL SHUTOFF switches ON and check for voltage. Turn MASTER and FUEL SHUTOFF switches OFF. If voltage is present, go to step 4. If voltage is not present, replace/repair wire 54B of flasher system panel wiring harness.

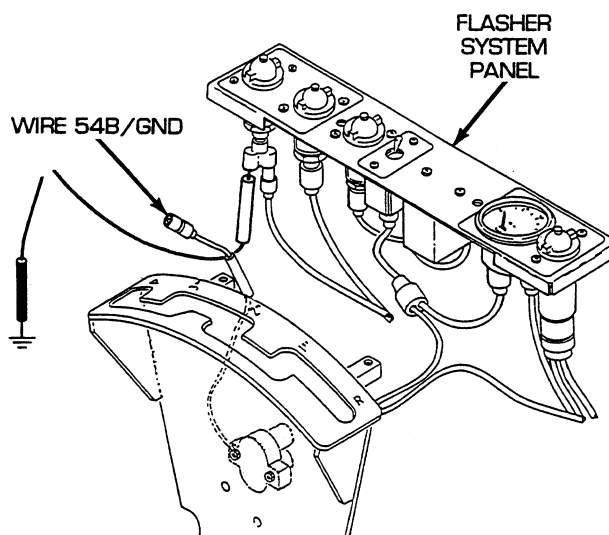

CORRECTIVE ACTION –Continued

4. Reconnect wire 54B of flasher system panel wiring harness to diode lead assembly connector. Disconnect wire 54B/GND of diode assembly from connector. Place red lead of multimeter on pin of connector and black lead to ground. Turn MASTER and FUEL SHUTOFF switches OFF. If voltage is present, repair/replace wire 54B/GND of diode lead assembly from connector to GND (see WP 0238 00). If voltage is not present, repair/replace connector of diode lead assembly (see WP 0238 00).

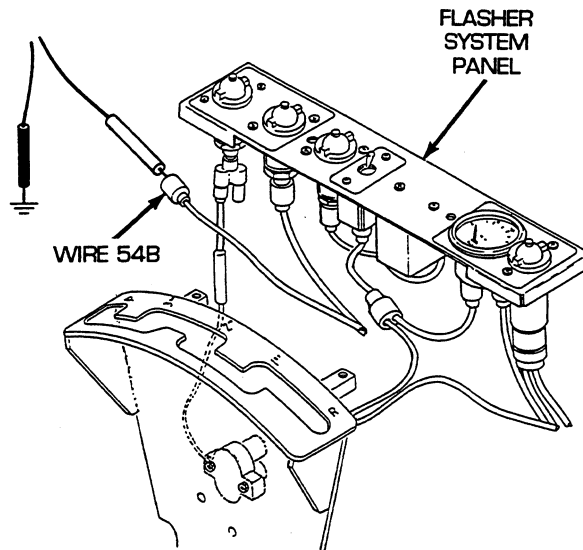

5. Reconnect wire 54B of flasher system panel wiring harness to connector at fire extinguisher interlock switch. Disconnect flasher system panel wiring harness Y-connector from wire 54A of fire extinguisher interlock switch assembly. Place red lead of multimeter in wire 54A and black lead to ground. Turn MASTER and FUEL SHUTOFF switches ON, release fire extinguisher interlock switch and check for voltage. Turn MASTER, FUEL SHUTOFF, and fire extinguisher interlock switches OFF. If voltage is present, replace connector of flasher system panel wiring harness (see WP 0197 00). If voltage is not present, troubleshoot fuel shutoff solenoid circuit.

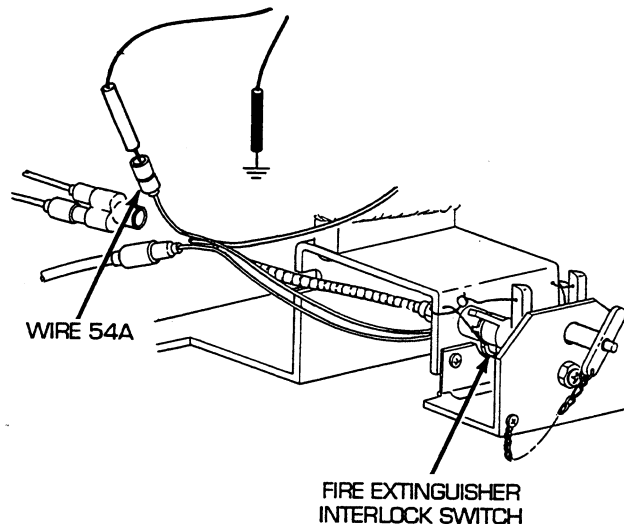

END OF WORK PACKAGE

UNIT MAINTENANCE
RECOVERY VEHICLE, FULL TRACKED: MEDIUM, M88A1
NSN 2350-00-122-6826, EIC AQA

ELECTRIC IN-TANK FUEL PUMP TROUBLESHOOTING PROCEDURE

INITIAL SETUP:

Tools and Special Tools

Tool kit, general mechanic's (item 59, WP 0490 00)

References

- WP 0042 00
- WP 0116 00
- WP 0159 00

References (cont.)

- WP 0199 00
- WP 0202 00
- WP 0203 00
- WP 0206 00
- WP 0218 00
- TM 9-2350-256-10

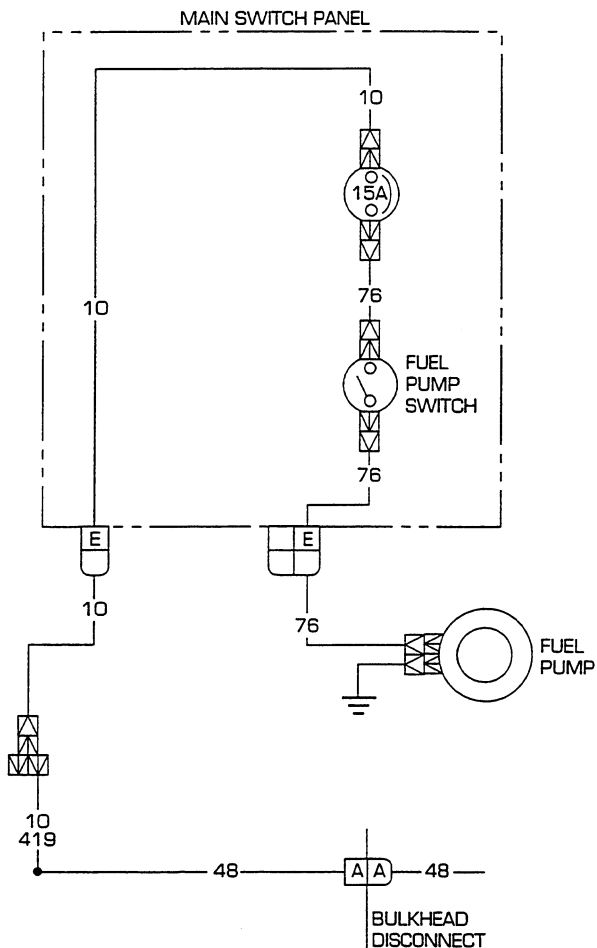
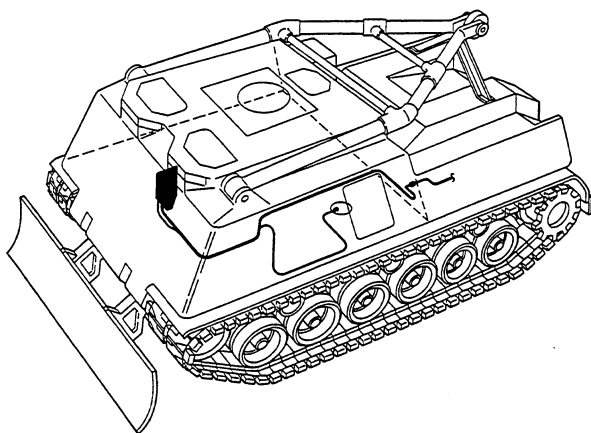

Troubleshooting Procedure

Electric In-Tank Fuel Pump

Symptom

Electric in-tank fuel pump malfunctioning.

Malfunction

Electric in-tank fuel pump fails to operate. Do steps 1 thru 11.

CORRECTIVE ACTION

WARNING

Remove all jewelry such as rings, dog tags, bracelets, etc. If jewelry contacts a metal surface a direct short may result in instant heating of tools, damage to equipment, and injury or death to personnel.

1. Remove four screws (1), four lockwashers (2), four flat washers (3), and fuel transmitter center left floor access plate (4). Remove fuse housing and inspect fuse. If fuse is unserviceable, replace fuse (see WP 0116 00). If fuse is serviceable and electric in-tank pump still fails to operate, go to step 2.

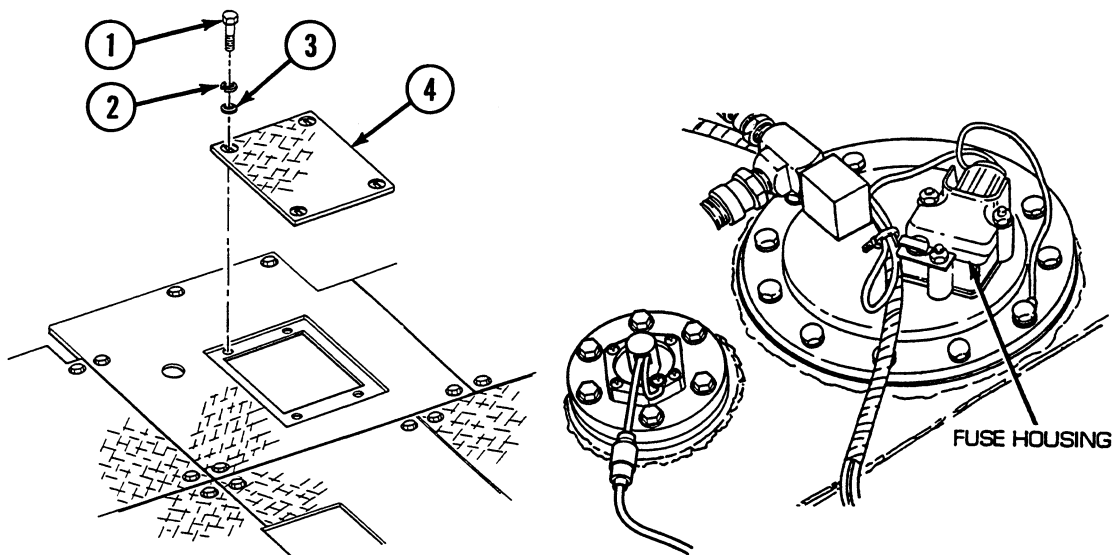

CORRECTIVE ACTION –Continued

2. Disconnect switch panel to neutral safety to bulkhead wiring harness connector from fuel pump. Place red lead of multimeter in wire 76 of connector and black lead to ground. Turn MASTER and FUEL PUMP switches ON and check for voltage. Turn MASTER and FUEL PUMP switches OFF. If voltage is present, go to step 3. If voltage is not present, go to step 4.

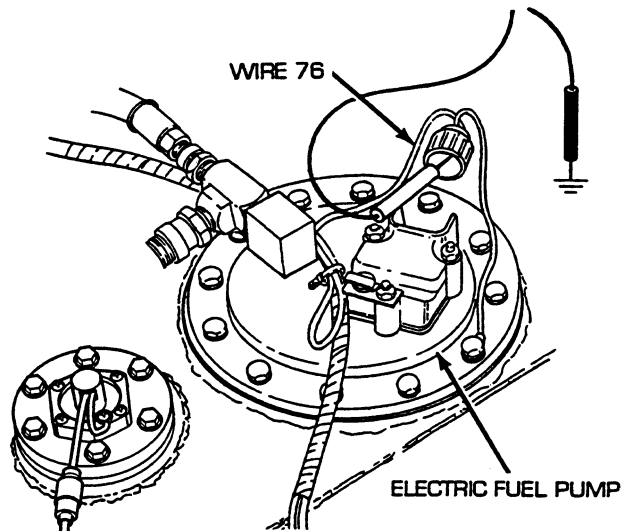

3. Place red lead of multimeter in wire GND of connector and black lead to ground. Check for continuity. If continuity is present, replace electric fuel pump (see WP 0116 00). If continuity is not present, repair/replace wire GND of switch panel to neutral safety to bulkhead wiring harness (see WP 0203 00).

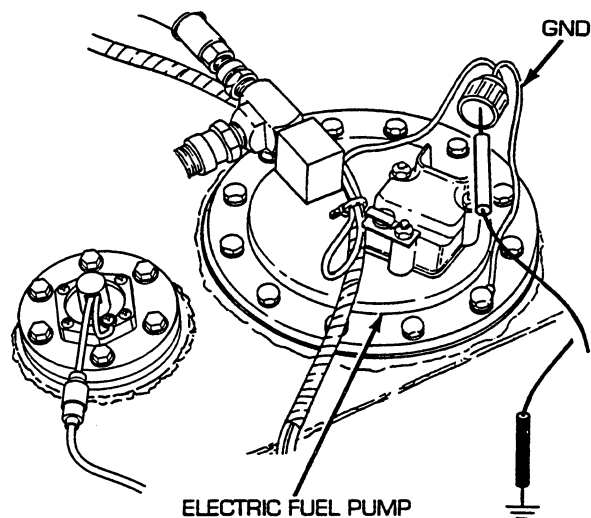

CORRECTIVE ACTION –Continued

4. Reconnect switch panel to neutral safety to bulkhead wiring harness connector to fuel pump. Remove three screws (5), three lockwashers (6), ground lead (7), flat washer (8), and release main switch panel (9) from mounting brackets. Disconnect switch panel to gage panel and miscellaneous switches wiring harness from main switch panel. Place red lead of multimeter on pin E of wire 10 and black lead to ground. Turn MASTER switch on, and check for voltage. Turn MASTER switch OFF. If voltage is present, go to step 5. If voltage is not present, go to step 9.

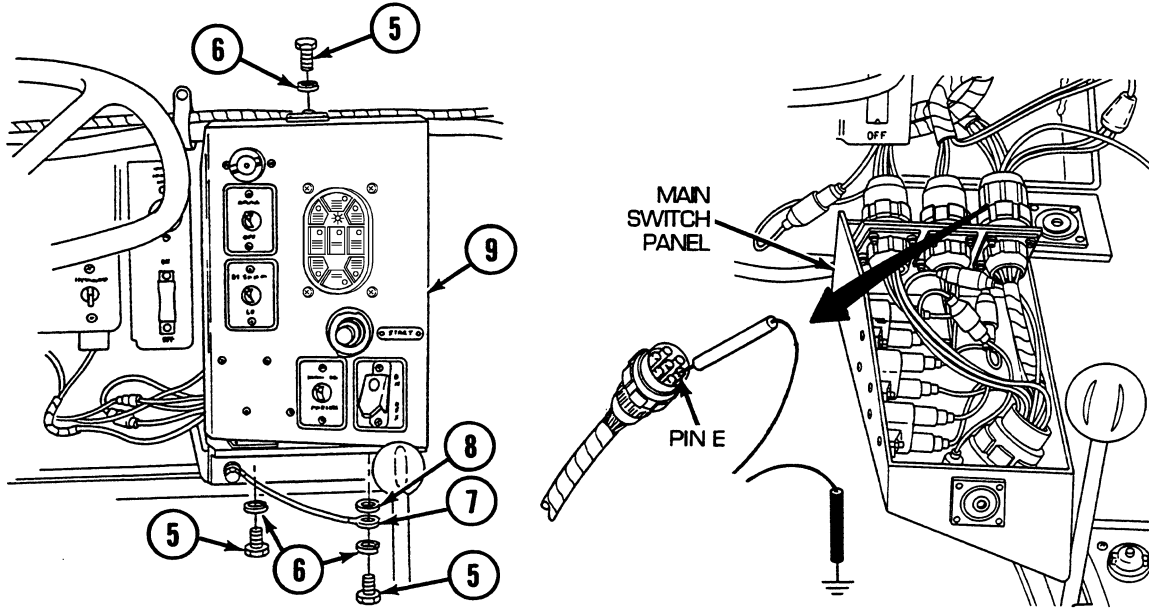

5. Reconnect switch panel to gage panel and miscellaneous switches wiring harness to main switch panel. Disconnect switch panel to neutral safety to bulkhead wiring harness from main switch panel. Place red lead of multimeter in socket E of wire 76 and black lead to ground. Turn MASTER and FUEL PUMP switches ON and check for voltage. Turn MASTER and FUEL PUMP switches OFF. If voltage is present, repair/replace wire 76 of switch panel to neutral safety to bulkhead wiring harness (see WP 0203 00). If voltage is not present, go to step 6.

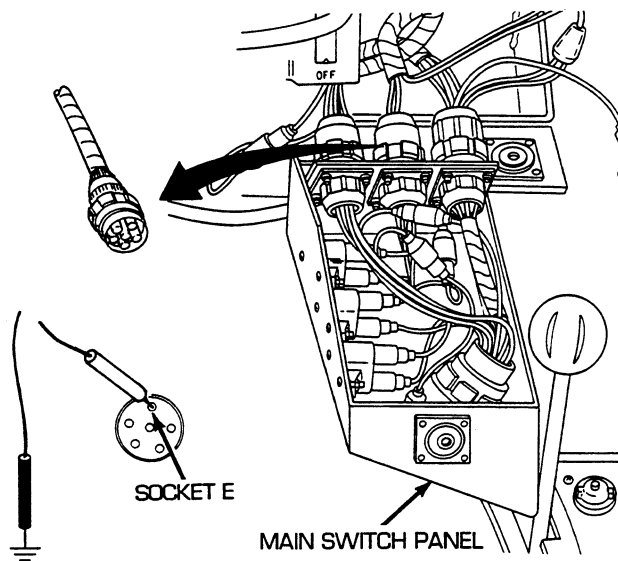

CORRECTIVE ACTION –Continued

6. Reconnect switch panel to neutral safety to bulkhead wiring harness to main switch panel. Disconnect wire 76 from FUEL PUMP switch side of 15 A circuit breaker. Place red lead of multimeter on terminal of 15 A circuit breaker and black lead to ground. Turn MASTER switch on, and check for voltage. Turn MASTER switch OFF. If voltage, is present, go to step 8. If voltage is not present, go to step 7.

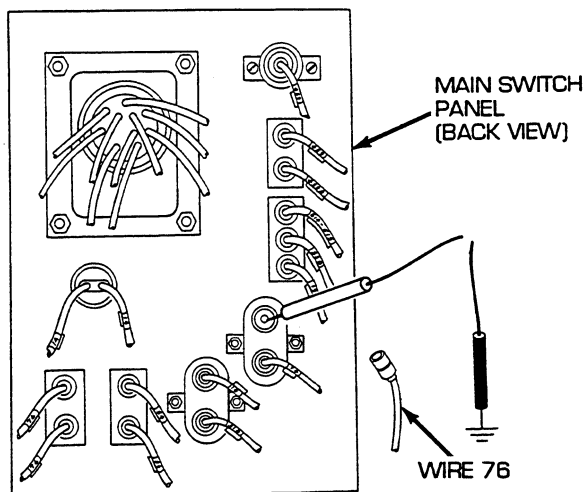

7. Reconnect wire 76 to FUEL PUMP switch side of 15 A circuit breaker. Disconnect wire 10 from 15 A circuit breaker. Place red lead of multimeter in wire 10 and black lead to ground. Turn MASTER switch on and check for voltage. Turn MASTER switch OFF. If voltage is present, replace circuit breaker (see WP 0159 00). If voltage is not present, repair/replace wire 10 of main lighting and B.O. selector switch wiring harness (see WP 0218 00).

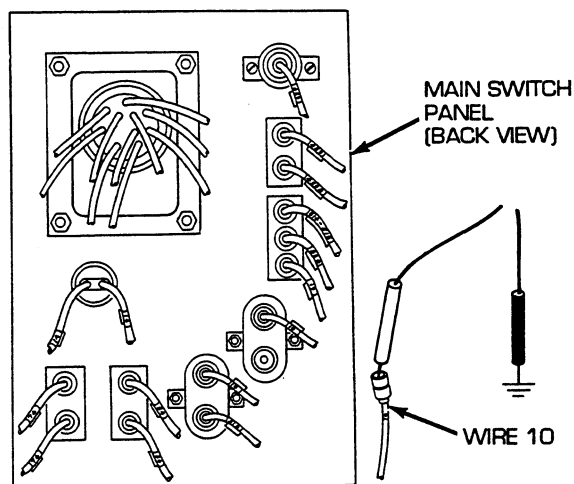

CORRECTIVE ACTION –Continued

8. Reconnect wire 10 to 15 A circuit breaker. Disconnect wire 76 from circuit breaker side of FUEL PUMP switch. Place red lead of multimeter in wire 76 and black lead to ground. Turn MASTER switch on, and check for voltage. Turn MASTER switch OFF. If voltage is present, go to step 9. If voltage is not present, repair/replace wire 76 of fuel pump switch panel lead assembly (see WP 0199 00).

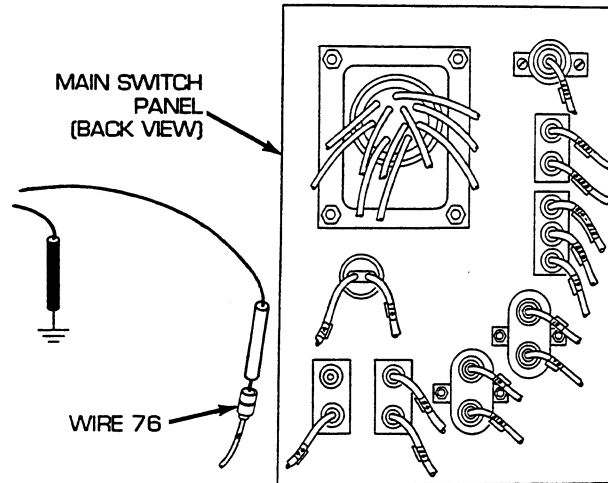

9. Reconnect wire 76 to circuit breaker side of FUEL PUMP switch. Disconnect wire 76 from panel side of FUEL PUMP switch. Place red lead of multimeter on terminal of FUEL PUMP switch and black lead to ground. Turn MASTER and FUEL PUMP switches ON and check for voltage. Turn MASTER and FUEL PUMP switches OFF. If voltage is present, repair/replace wire 76 of starter switch wiring harness (see WP 0206 00). If voltage is not present, replace FUEL PUMP switch (see WP 0159 00).

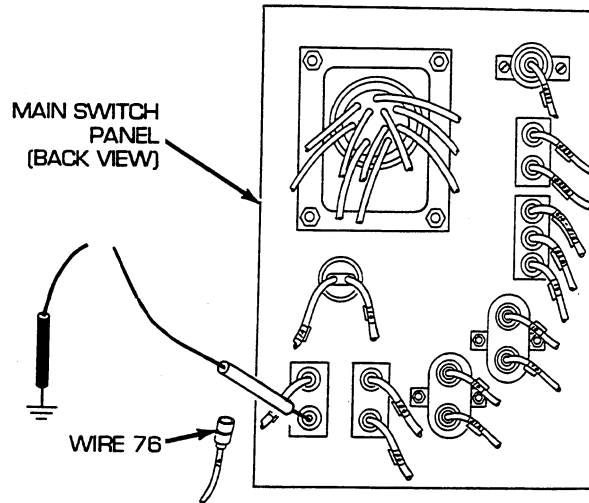

10. Disconnect wire 10-419 from Y-connector of switch panel, radio, and bilge pump to bulkhead wiring harness at main switch panel. Turn MASTER switch on, and check for voltage. If voltage is present, repair wire 419 from Y-connector at main switch panel to APU control box bulkhead wiring harness. If voltage is not present, go to step 11.

CORRECTIVE ACTION –Continued

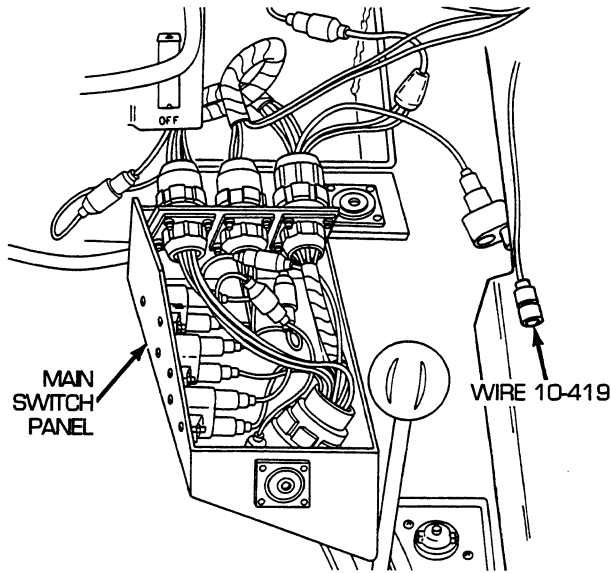

11. Reconnect wire 10-419 to Y-connector of switch panel, radio, and bilge pump to bulkhead wiring harness to main switch panel. Install main switch panel (9), flat washer (8), ground lead (7), three lockwashers (6), and three screws (5) to mounting bracket. Open air inlet doors (TM 9-2350-256-10). Disconnect wire 48 pin A from bulkhead to master relay wiring harness. Place red multimeter lead in socket and black lead to ground. Turn MASTER switch on and check for voltage. If voltage is present, repair or replace switch panel, radio, and bilge pump to bulkhead wiring harness (see WP 0202 00). If voltage is not present, troubleshoot master relay circuit (see WP 0042 00).

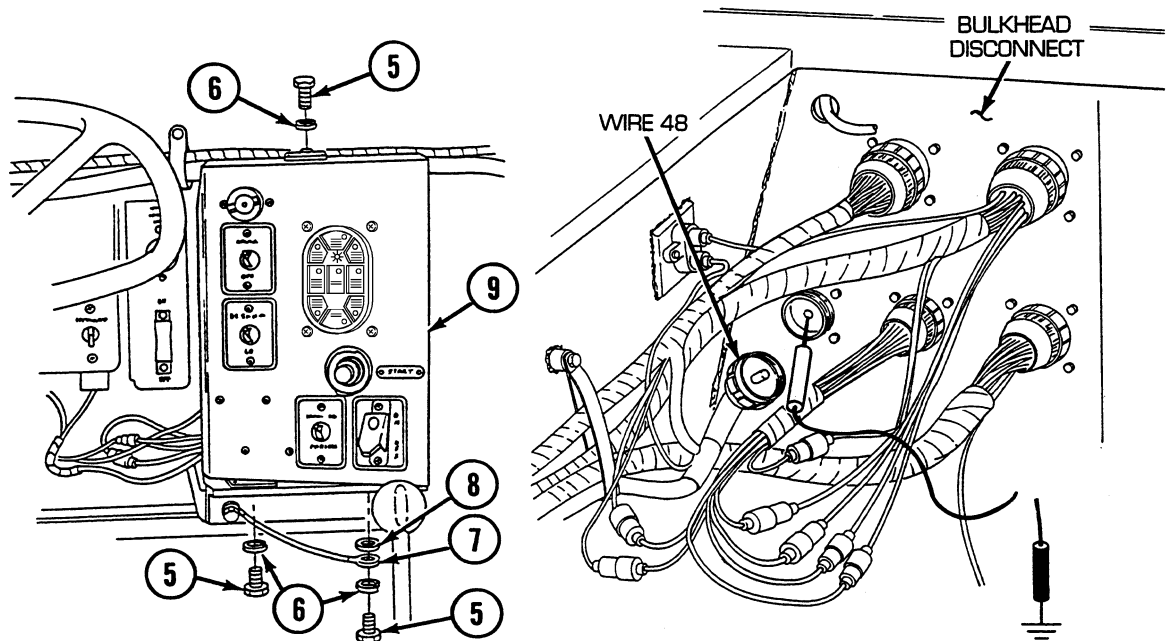

END OF WORK PACKAGE

UNIT MAINTENANCE
RECOVERY VEHICLE, FULL TRACKED: MEDIUM, M88A1
NSN 2350-00-122-6826, EIC AQA
FUEL GAGE TROUBLESHOOTING PROCEDURE

INITIAL SETUP:

Tools and Special Tools

Tool kit, general mechanic's (item 59, WP 0490 00)

References

- WP 0121 00
- WP 0157 00
- WP 0193 00

References (cont.)

- WP 0194 00
- WP 0195 00
- WP 0200 00
- WP 0222 00
- WP 0223 00
- TM 9-2350-256-10

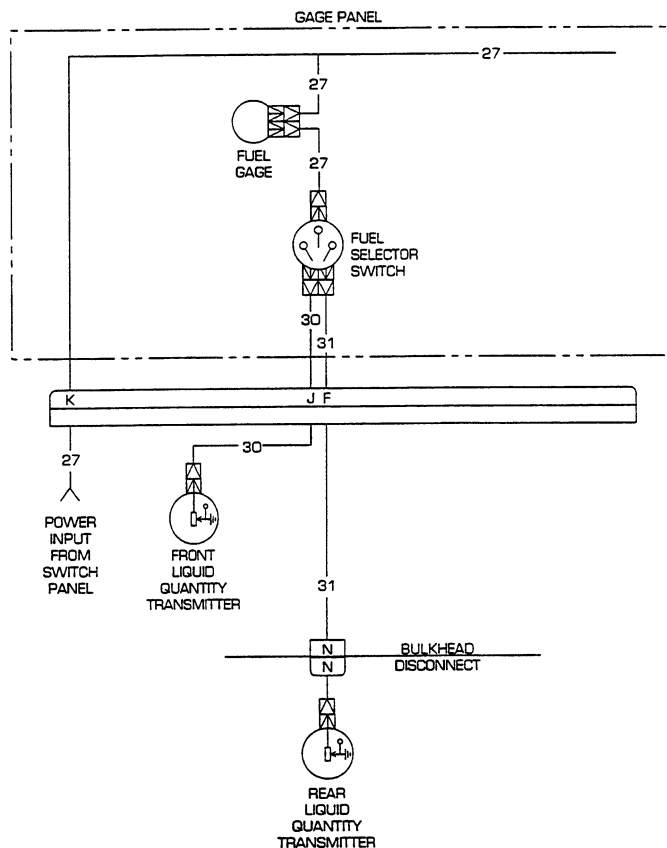
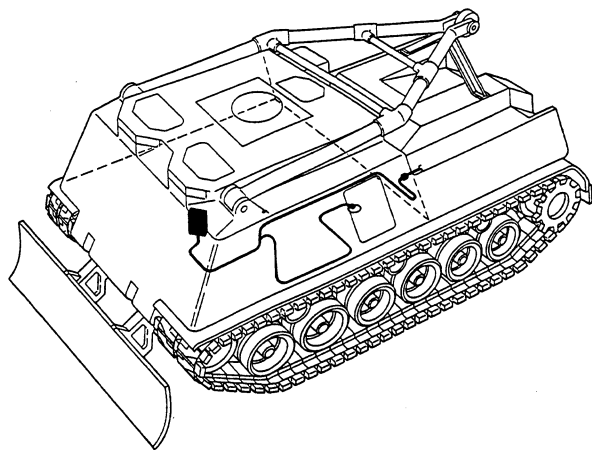

Troubleshooting Procedure

Fuel Gage

Symptom

Fuel gage malfunctioning.

Malfunction

Fuel gage does not operate in either FRONT or REAR position. Do steps 1 thru 8.

CORRECTIVE ACTION

WARNING

Remove all jewelry such as rings, dog tags, bracelets, etc. If jewelry contacts a metal surface a direct short may result in instant heating of tools, damage to equipment, and injury or death to personnel.

1. Remove three screws (1), three lockwashers (2), two screws (3), two lockwashers (4), and ground strap (5) and release gage panel (6) from mounting brackets. Remove gage panel to bulkhead wiring harness from gage panel. Place red lead of multimeter in socket K of wire 27 and black lead to ground. Turn MASTER switch on and check for voltage. Turn MASTER switch OFF. If voltage is present, go to step 2. If voltage is not present, troubleshoot power control lever circuit.

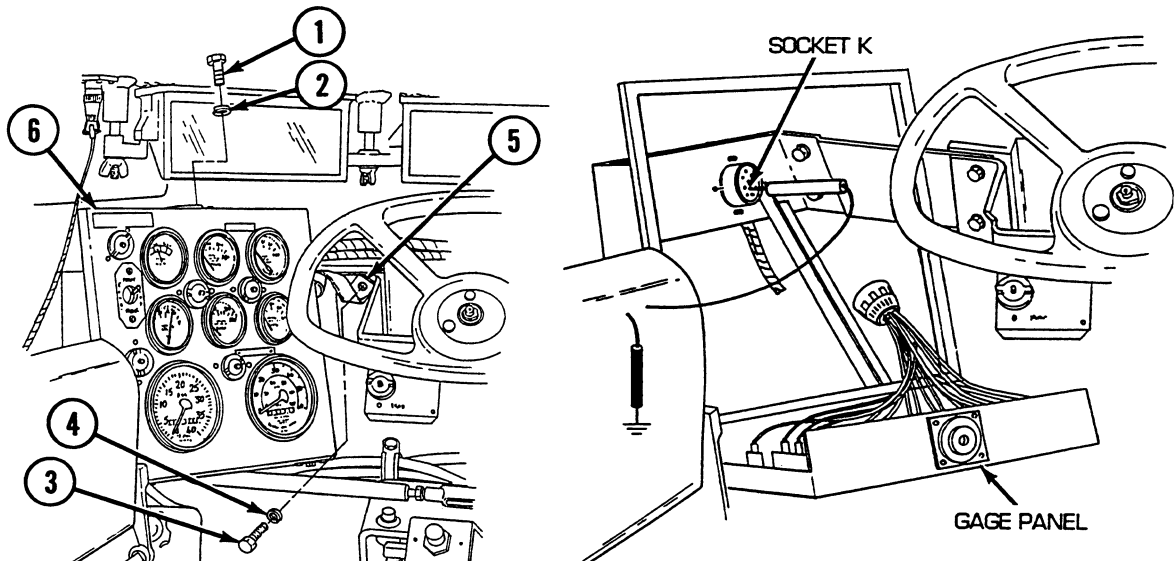

CORRECTIVE ACTION –Continued

2. Reconnect gage panel to bulkhead wiring harness to gage panel. Disconnect wire 27F from fuel gage. Place red lead of multimeter on wire 27F and black lead to ground. Turn MASTER switch on and check for voltage. Turn MASTER switch OFF. If voltage is present, go to step 3. If voltage is not present, repair/replace wire 27F of gage panel wiring harness (see WP 0193 00).

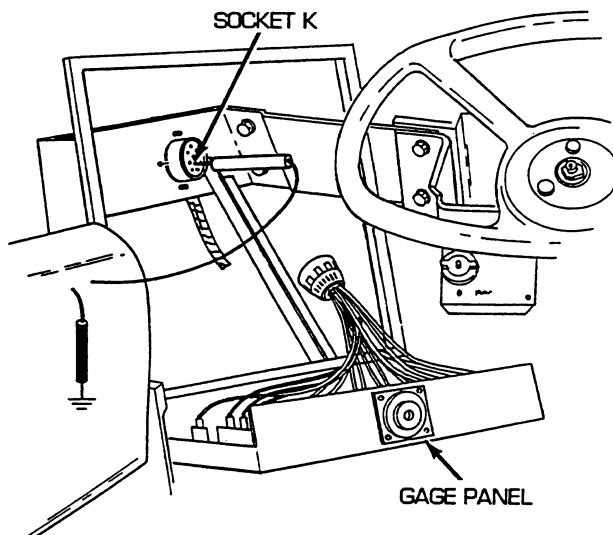

3. Reconnect wire 27F to fuel gage. Disconnect wire 28 from fuel gage. Place one end of jumper wire on receptacle on fuel gage and other end to ground. Turn MASTER switch on and check for fuel gage to read full scale. Turn MASTER switch OFF. If fuel gage operates, go to step 4. If fuel gage fails to operate, replace fuel gage (see WP 0157 00).

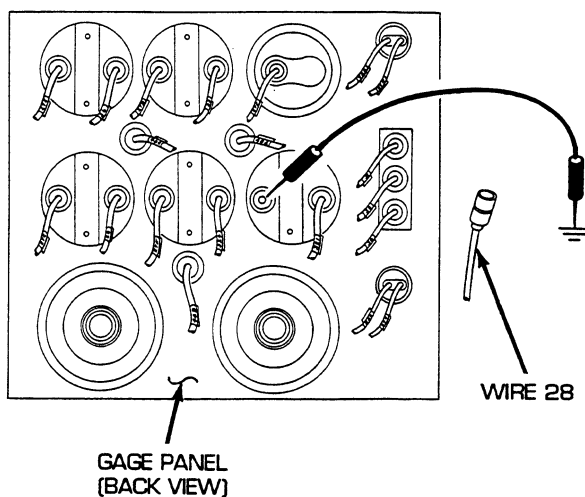

CORRECTIVE ACTION –Continued

4. Reconnect wire 28 to fuel gage. Disconnect wire 28 from fuel selector switch. Turn MASTER switch on and check fuel gage. Fuel gage should read full. Ground wire 28 at fuel selector switch end. Fuel gage should read empty. Turn MASTER switch OFF. If fuel gage reads correctly, go to step 5. If fuel gage reads incorrectly, repair/replace wire 28 of fuel gage panel lead assembly (see WP 0200 00).

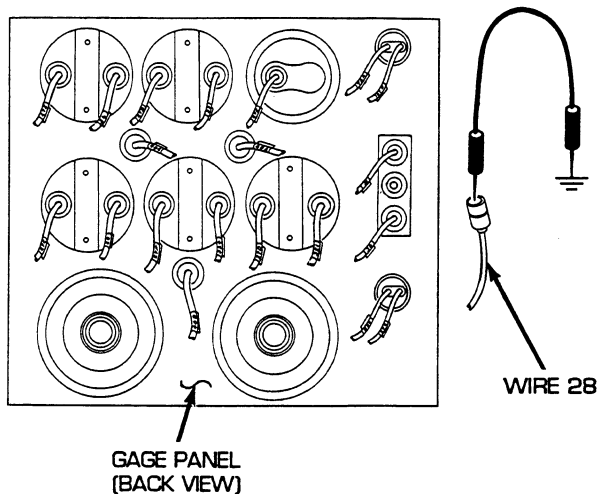

5. Reconnect wire 28 to fuel selector switch. Remove wires 30 and 31 from fuel selector switch. Turn MASTER switch on and check fuel gage for operation in both FRONT and REAR positions. Fuel gage should read full for both tanks. Place one end of jumper wires in both switch positions and other ends to ground. Check fuel gage for operation in both FRONT and REAR positions. Fuel gage should read empty. Turn MASTER switch OFF. If fuel gage reads correctly, go to step 6. If fuel gage reads incorrectly, replace fuel selector switch (see WP 0157 00).

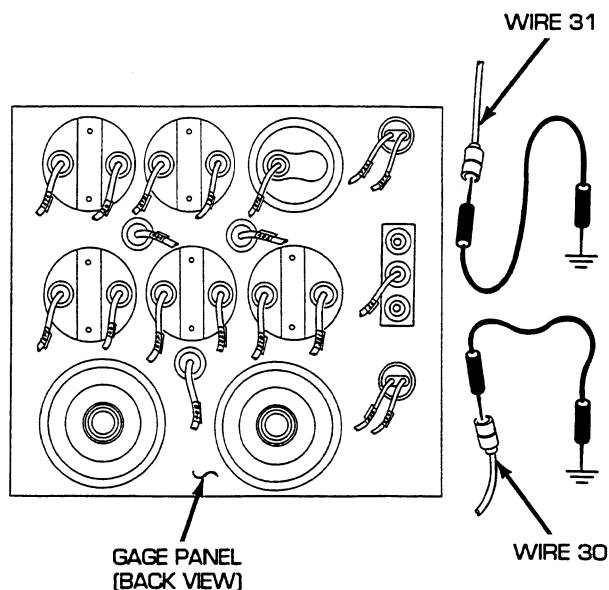

CORRECTIVE ACTION –Continued**NOTE**

Do step 6 for front fuel lever transmitter, do step 7 for rear fuel level transmitter.

6. Reconnect wires 30 and 31 to fuel selector switch. Remove four screws (7), four lockwashers (8), four flat washers (9), and fuel transmitter center left floor access plate (10). Disconnect wire 30 from fuel level transmitter on front fuel tank. Place red lead of multimeter in wire 30 at fuel level transmitter and black lead to ground. If voltage is present, replace fuel level transmitter (see WP 0121 00). If voltage is not present, repair/replace wire 30 of gage panel to bulkhead wiring harness (see WP 0194 00 for dual voltage; 0195 00 for single voltage).

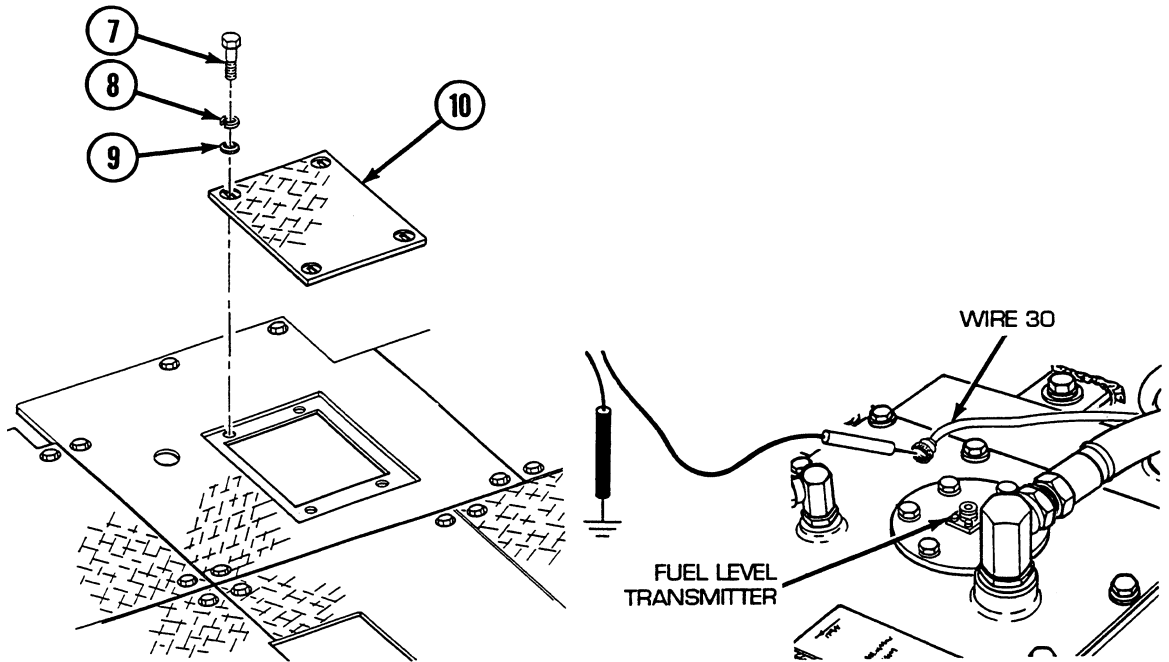

CORRECTIVE ACTION –Continued

7. Open air inlet doors (TM 9-2350-256-10). Disconnect bulkhead to engine bracket and rear fuel tank transmitter wiring harness from bulkhead disconnect. Place red lead of multimeter in pin N of wire 31 and black lead to ground and check for voltage. If voltage is present, go to step 8. If voltage is not present, repair/replace wire 31 of gage panel to bulkhead wiring harness (see WP 0194 00 for dual voltage; 0195 00 for single voltage).

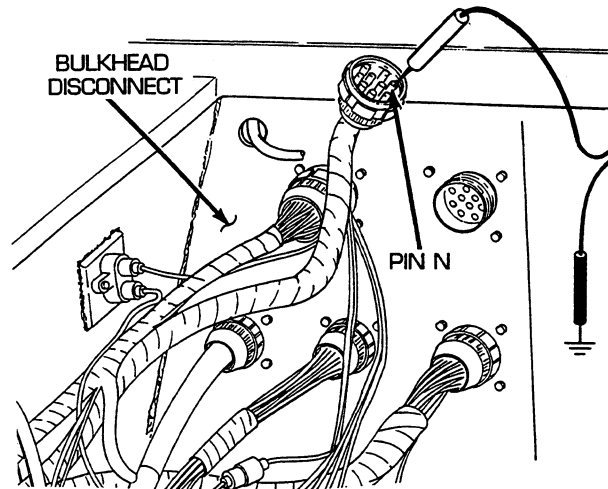

8. Reconnect bulkhead to engine bracket and rear fuel tank transmitter wiring harness to bulkhead. Disconnect wire 31 from rear fuel tank transmitter. Place red lead of multimeter in wire 31 and black lead to ground and check for voltage. If voltage is present, replace rear fuel tank transmitter (see WP 0121 00). If voltage is not present, repair/replace bulkhead to engine bracket and rear fuel tank transmitter wiring harness (see WP 0222 00 for dual voltage; 0223 00 for single voltage).

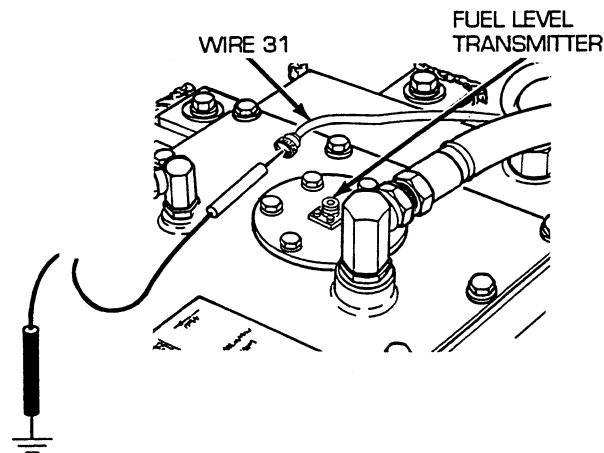

END OF WORK PACKAGE

UNIT MAINTENANCE
RECOVERY VEHICLE, FULL TRACKED: MEDIUM, M88A1
NSN 2350-00-122-6826, EIC AQA

ENGINE OIL TEMPERATURE GAGE TROUBLESHOOTING PROCEDURE

INITIAL SETUP:

Tools and Special Tools

Tool kit, general mechanic's (item 59, WP 0490 00)

References

- WP 0098 00
- WP 0157 00
- WP 0171 00
- WP 0193 00
- WP 0194 00

References (cont.)

- WP 0195 00
- WP 0207 00
- WP 0208 00
- WP 0222 00
- WP 0223 00
- WP 0336 00
- TM 9-2350-256-10

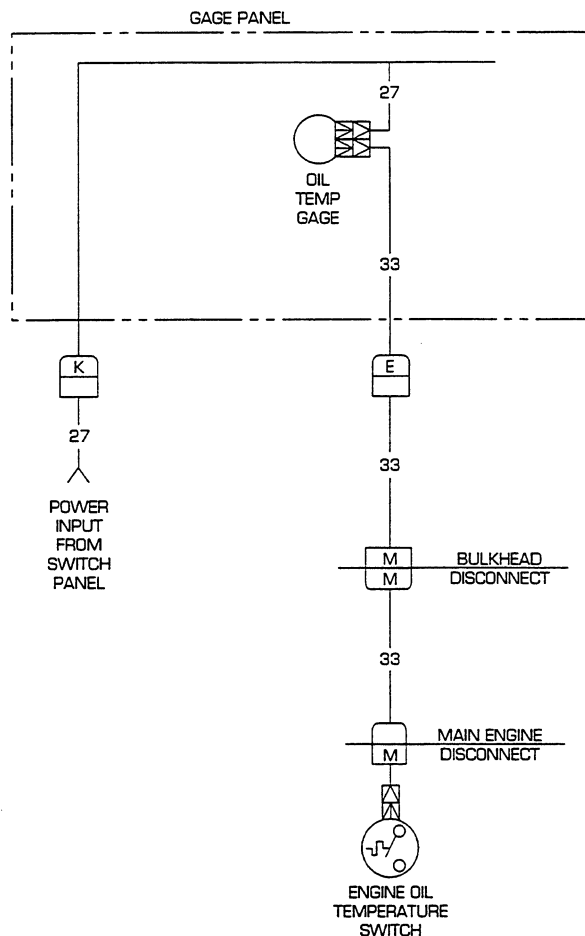
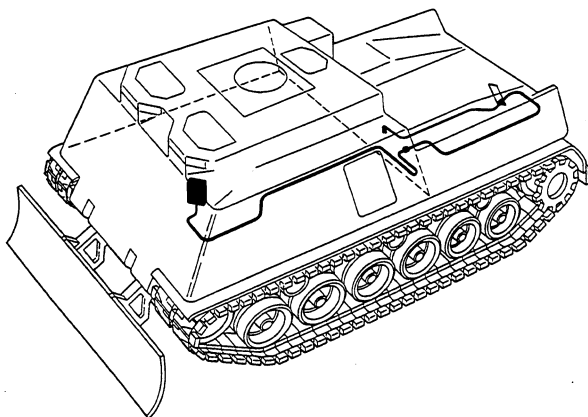

Troubleshooting Procedure

Engine Oil Temperature Gage

Symptom

Engine oil temperature gage malfunctioning.

Malfunction

Engine oil temperature gage does not operate. Do steps 1 through 7.

CORRECTIVE ACTION

WARNING

Remove all jewelry such as rings, dog tags, bracelets, etc. If jewelry contacts a metal surface a direct short may result in instant heating of tools, damage to equipment, and injury or death to personnel.

1. Remove three screws (1), three lockwashers (2), two screws (3), two lockwashers (4), and ground strap (5) and release gage panel (6) from mounting brackets. Remove gage panel to bulkhead wiring harness from gage panel. Place red lead of multimeter on socket K of wire 27 and black lead to ground. Turn MASTER switch on and check for voltage. Turn MASTER switch OFF. If voltage is present, go to step 2. If voltage is not present, troubleshoot power control lever circuit.

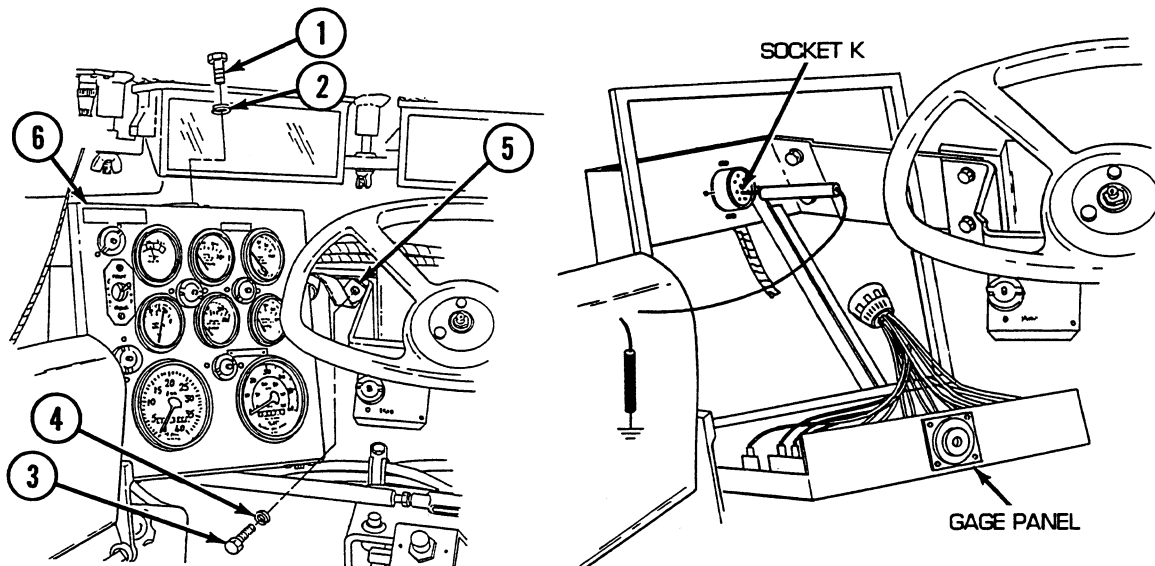

CORRECTIVE ACTION –Continued

2. Reconnect gage panel to bulkhead wiring harness to gage panel. Disconnect wire 27C from engine oil temperature gage. Place red lead of multimeter in wire 27C and black lead to ground. Turn MASTER switch on and check for voltage. Turn MASTER switch OFF. If voltage is present, go to step 3. If voltage is not present, repair/replace wire 27C of gage panel wiring harness (see WP 0193 00).

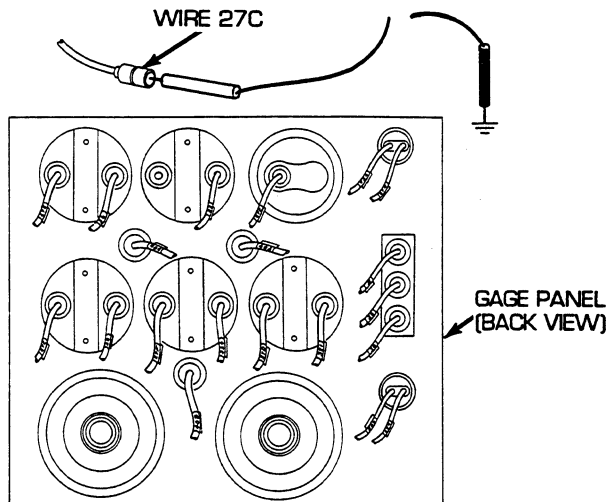

3. Reconnect wire 27C to engine oil temperature gage. Disconnect wire 33 from engine oil temperature gage. Turn MASTER switch on and check engine oil temperature gage for operation. Engine oil temperature gage should read full scale. Ground case of engine oil temperature gage and check gage for operation. Gage should read "0." Turn MASTER switch OFF. If engine oil temperature gage reads correctly, go to step 4. If engine oil temperature gage fails to read correctly, replace engine oil temperature gauge (see WP 0157 00).

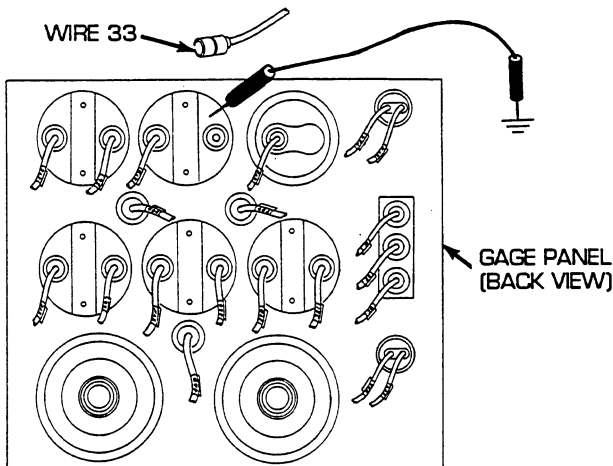

CORRECTIVE ACTION –Continued

4. Disconnect gage panel to bulkhead wiring harness from gage panel. Check wire 33 in gauge panel harness for continuity by placing red lead of multimeter on wire 33 and black lead on pin E. If continuity is present, go to step 5. If continuity is not present, repair/replace wire 33 of gage panel wiring harness (see WP 0193 00).

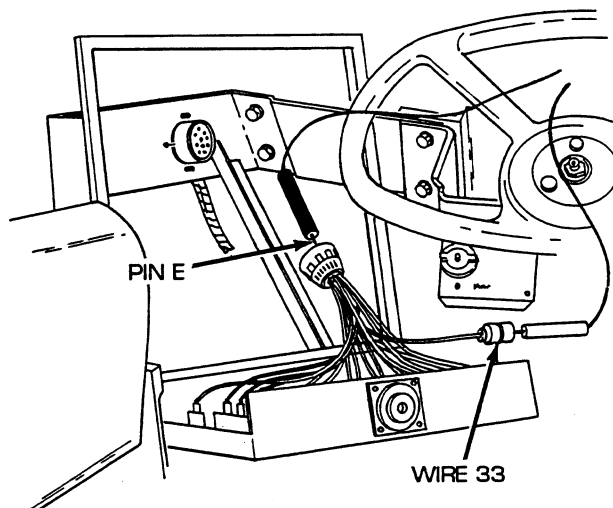

5. Reconnect wire 33 to engine oil temperature gage and gage panel to bulkhead wiring harness to gage panel. Install ground strap (5), two lockwashers (4), two screws (3), gage panel (6), three lockwashers (2), and three screws (1). Open air inlet doors (TM 9-2350-256-10). Disconnect bulkhead to engine bracket and rear fuel tank wiring harness from bulkhead disconnect. Place red lead of multimeter in socket M of wire 33 and black lead to ground. Turn MASTER switch on and check for voltage. Turn MASTER switch OFF. If voltage is present, go to step 6. If voltage is not present, repair/replace wire 33 of gage panel to bulkhead wiring harness (see WP 0194 00 for dual voltage; 0195 00 for single voltage).

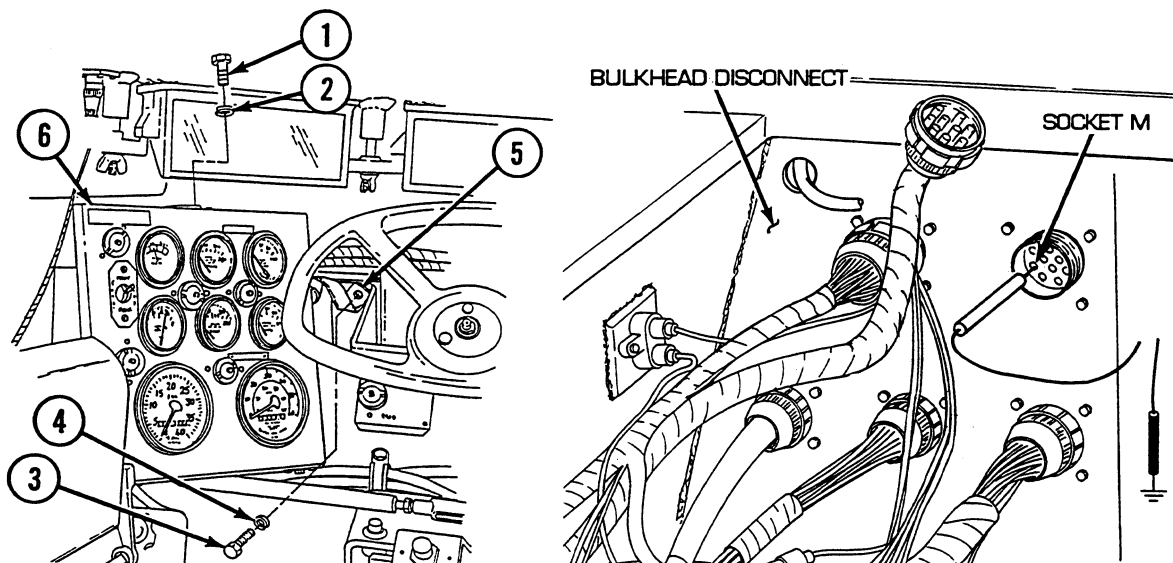

6. Reconnect bulkhead to engine bracket and rear fuel tank transmitter wiring harness to bulkhead. Remove engine deck (see WP 0336 00). Disconnect bulkhead to engine bracket and rear fuel tank transmitter wiring harness from engine disconnect. Place red lead of multimeter in socket H of wire 33 and black lead to ground. Turn MASTER switch on and check for voltage. Turn MASTER switch OFF. If voltage is present, go to step 7. If voltage is not present, repair/replace wire 33 of bulkhead to

CORRECTIVE ACTION –Continued

engine bracket and rear fuel tank transmitter wiring harness (see WP 0222 00 for dual voltage; 0223 00 for single voltage).

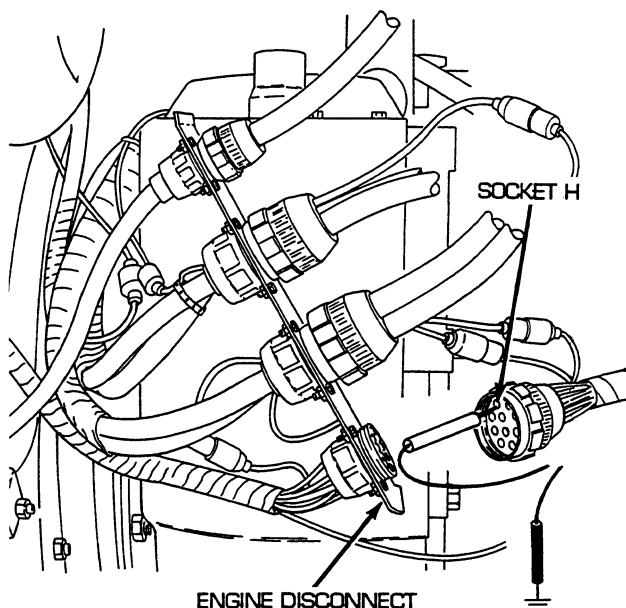

7. Reconnect bulkhead to engine bracket and rear fuel tank transmitter wiring harness to engine disconnect. Remove powerplant (see WP 0098 00). Disconnect wire 33 from engine oil temperature sending unit. Place red lead of multimeter on wire 33 and black lead to ground. Turn MASTER switch on and check for voltage. Turn MASTER switch OFF. If voltage is present, replace engine oil temperature sending unit (see WP 0171 00). If voltage is not present, repair/replace wire 33 of engine wiring harness (see WP 0207 00 for dual voltage; 0208 00 for single voltage).

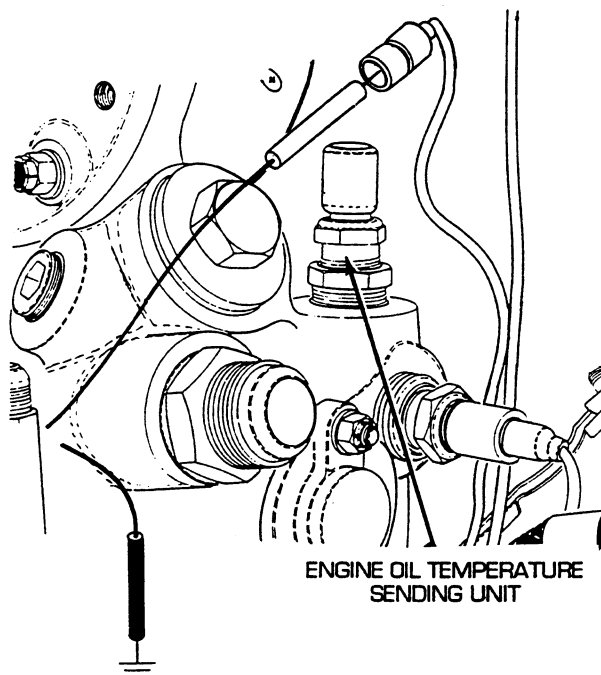

END OF WORK PACKAGE

UNIT MAINTENANCE
RECOVERY VEHICLE, FULL TRACKED: MEDIUM, M88A1
NSN 2350-00-122-6826, EIC AQA
ENGINE OIL PRESSURE GAGE TROUBLESHOOTING PROCEDURE

INITIAL SETUP:**Tools and Special Tools**

Tool kit, general mechanic's (item 59, WP 0490 00)

References

WP 0098 00

WP 0157 00

WP 0171 00

WP 0193 00

WP 0194 00

References (cont.)

WP 0195 00

WP 0207 00

WP 0208 00

WP 0222 00

WP 0223 00

WP 0336 00

TM 9-2350-256-10

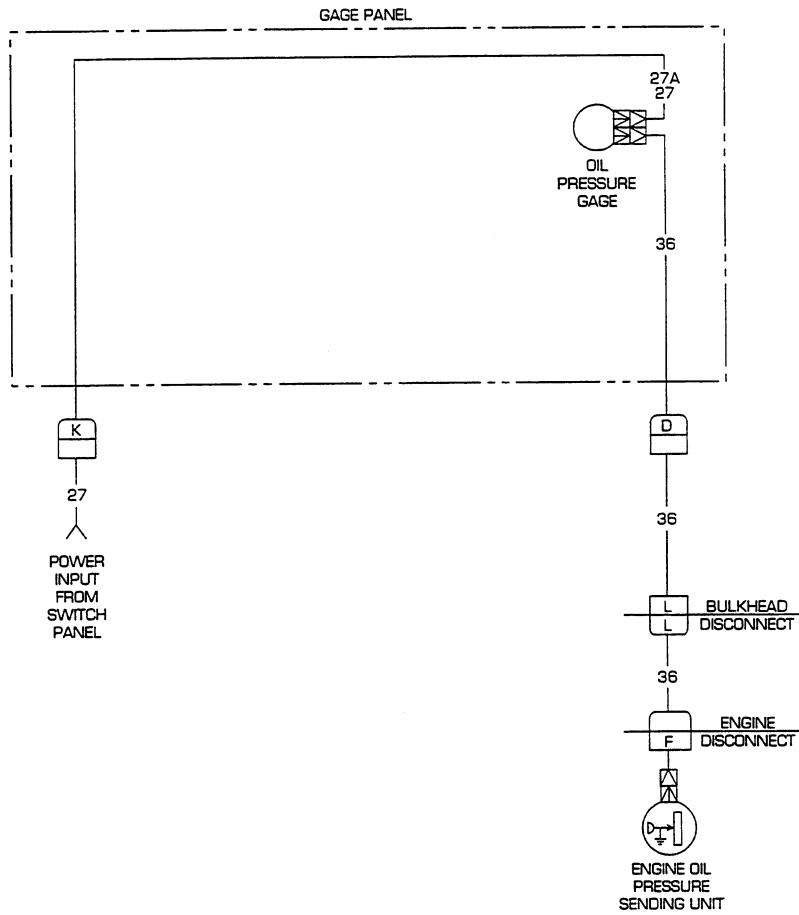
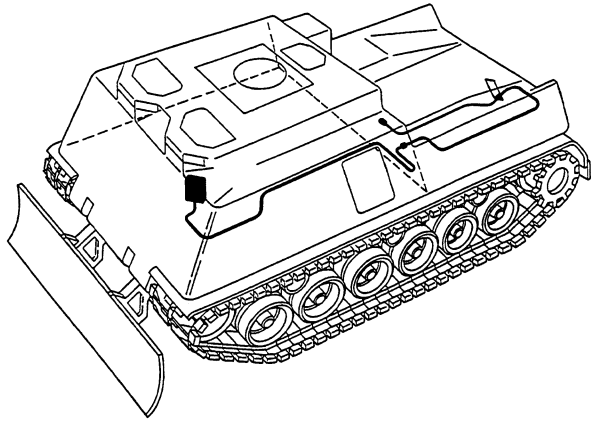

Troubleshooting Procedure**Engine Oil Pressure Gage****Symptom**

Engine oil pressure gage malfunctioning.

Malfunction

Engine oil pressure gage does not operate. Do steps 1 thru 7.

CORRECTIVE ACTION**WARNING**

Remove all jewelry such as rings, dog tags, bracelets, etc. If jewelry contacts a metal surface a direct short may result in instant heating of tools, damage to equipment, and injury or death to personnel.

1. Remove three screws (1), three lockwashers (2), two screws (3), two lockwashers (4), and ground strap (5) and release gage panel (6) from mounting brackets. Remove gage panel to bulkhead wiring harness from gage panel. Place red lead of multimeter in socket K of wire 27 and black lead to ground. Turn MASTER switch on and check for voltage. Turn MASTER switch OFF. If voltage is present, go to step 2. If voltage is not present, troubleshoot power control lever circuit.

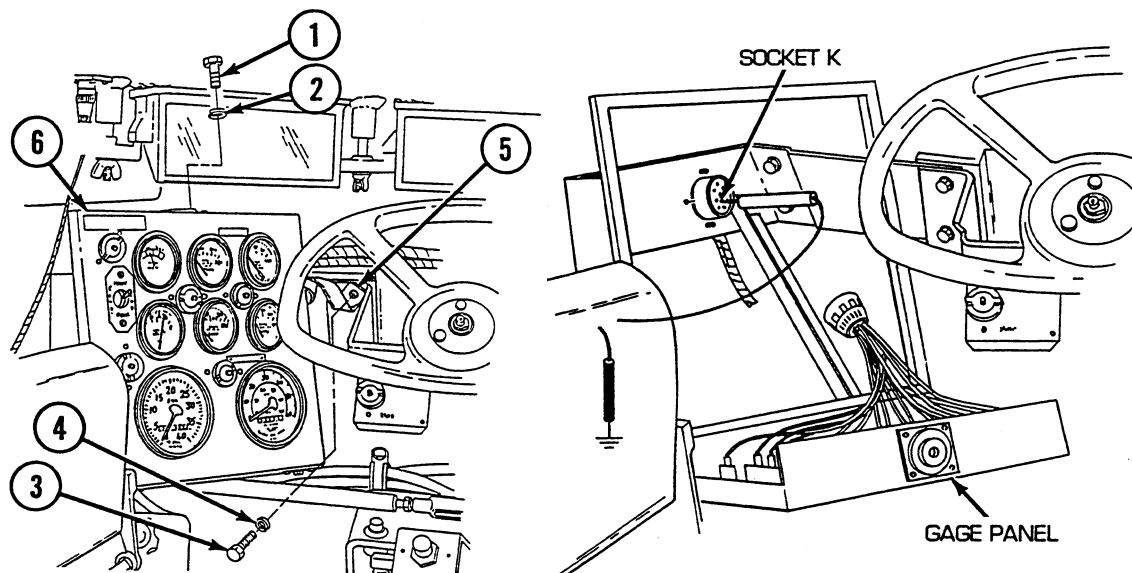

CORRECTIVE ACTION –Continued

2. Reconnect gage panel to bulkhead wiring harness to gage panel. Disconnect wire 27A from engine oil pressure gage. Place red lead of multimeter in wire 27A and black lead to ground. Turn MASTER switch on and check for voltage. Turn MASTER switch OFF. If voltage is present, go to step 3. If voltage is not present, repair/replace wire 27A of gage panel wiring harness (see WP 0193 00).

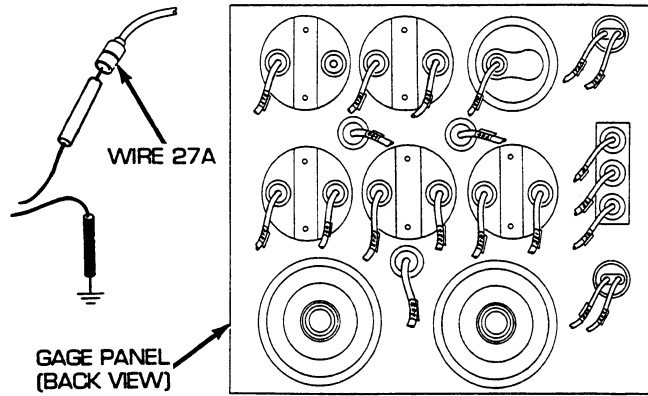

3. Reconnect wire 27A to engine oil pressure gage. Disconnect wire 36 from engine oil pressure gage. Turn MASTER switch on and check engine oil pressure gage for operation. Engine oil pressure gage should read "0." Ground case of engine oil pressure gage and check gage for operation. Gage should read full scale. Turn MASTER switch OFF. If engine oil pressure gage reads correctly, go to step 4. If engine oil pressure gage fails to read correctly, replace engine oil pressure gage (see WP 0157 00).

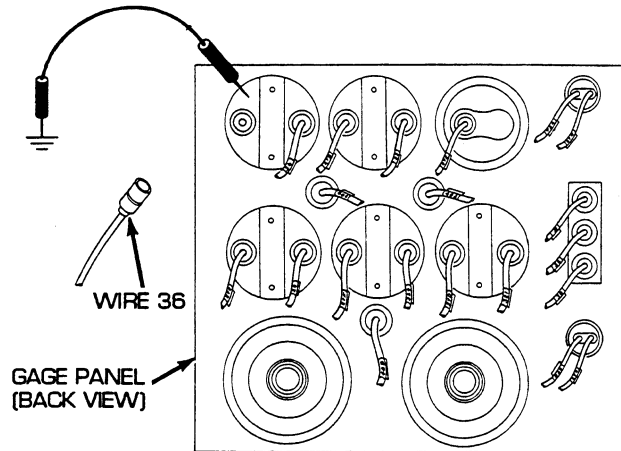

CORRECTIVE ACTION –Continued

4. Disconnect gage panel to bulkhead wiring harness from gage panel. Check wire 36 in gage panel harness for continuity by placing red lead of multimeter on wire 36 and black lead on pin D. If continuity is present, go to step 5. If continuity is not present, repair/replace wire 36 of gage panel wiring harness (see WP 0193 00).

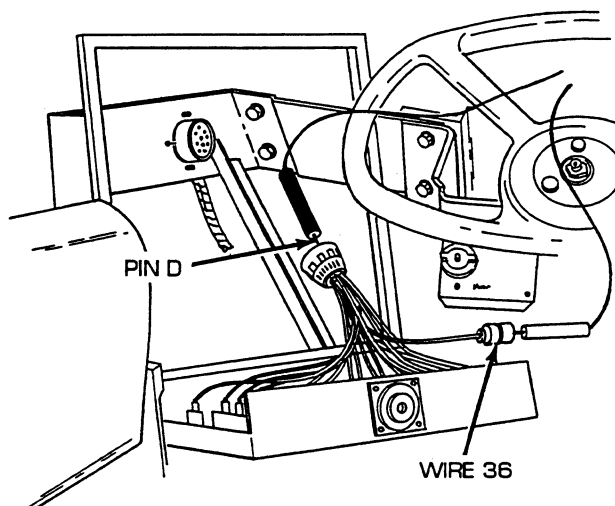

5. Reconnect wire 36 to engine oil pressure gage and gage panel to bulkhead wiring harness to gage panel. Install ground strap (5), two lockwashers (4), two screws (3), gage panel (6), three lockwashers (2), and three screws (1) to mounting brackets. Open air inlet doors (TM 9-2350-256-10). Disconnect bulkhead to engine bracket and rear fuel tank wiring harness from bulkhead disconnect. Place red lead of multimeter in socket L of wire 36 and black lead to ground. Turn MASTER switch on and check for voltage. Turn MASTER switch OFF. If voltage is present, go to step 6. If voltage is not present, repair/replace wire 36 of gage panel to bulkhead wiring harness (see WP 0194 00 for dual voltage; 0195 00 for single voltage).

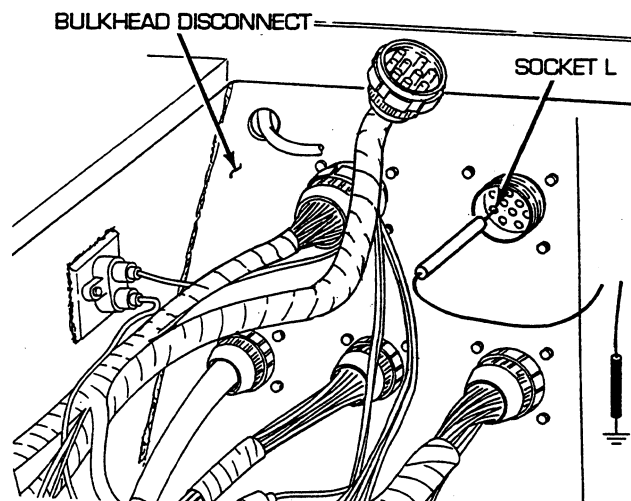
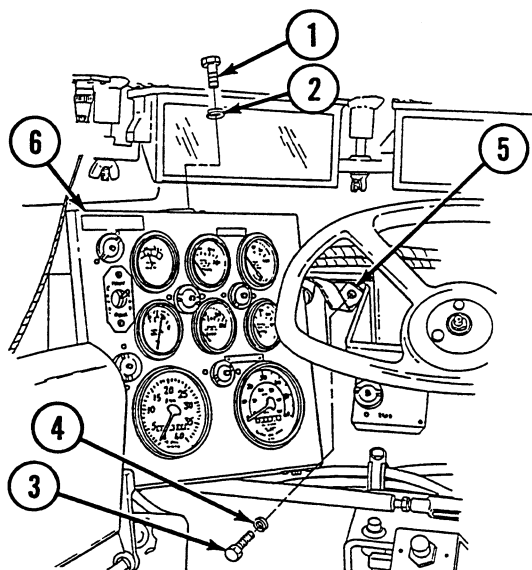

CORRECTIVE ACTION –Continued

6. Reconnect bulkhead to engine bracket and rear fuel tank wiring harness to bulkhead. Remove engine deck (see WP 0336 00). Disconnect bulkhead to engine bracket and rear fuel tank wiring harness to engine disconnect. Place red lead of multimeter in socket F of wire 36 and black lead to ground. Turn MASTER switch on and check for voltage. Turn MASTER switch OFF. If voltage is present, go to step 7. If voltage is not present, repair/replace wire 36 of bulkhead to engine bracket and rear fuel tank transmitter wiring harness (see WP 0222 00 for dual voltage; 0223 00 for single voltage).

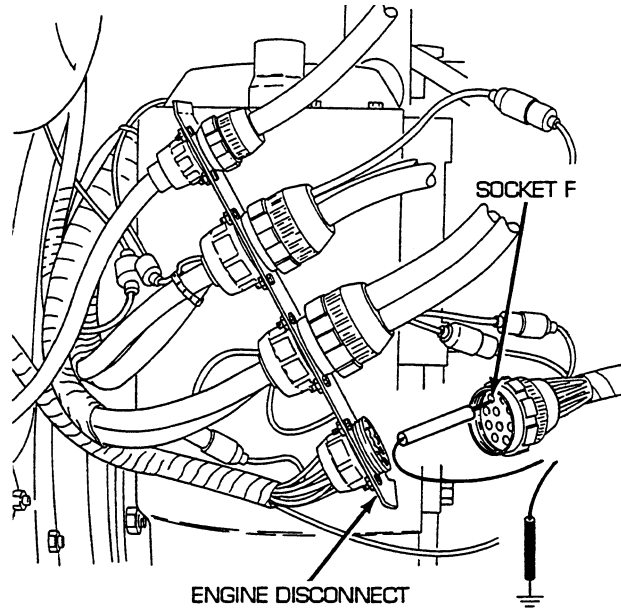

7. Reconnect bulkhead to engine bracket and rear fuel tank transmitter wiring harness to engine disconnect. Remove powerplant (see WP 0098 00). Disconnect wire 36 from engine oil pressure sending unit. Place red lead of multimeter in wire 36 and black lead to ground. Turn MASTER switch on and check for voltage. Turn MASTER switch OFF. If voltage is present, replace engine oil pressure sending unit (see WP 0171 00). If voltage is not present, repair/replace wire 36 of engine wiring harness (see WP 0207 00 for dual voltage; 0208 00 for single voltage).

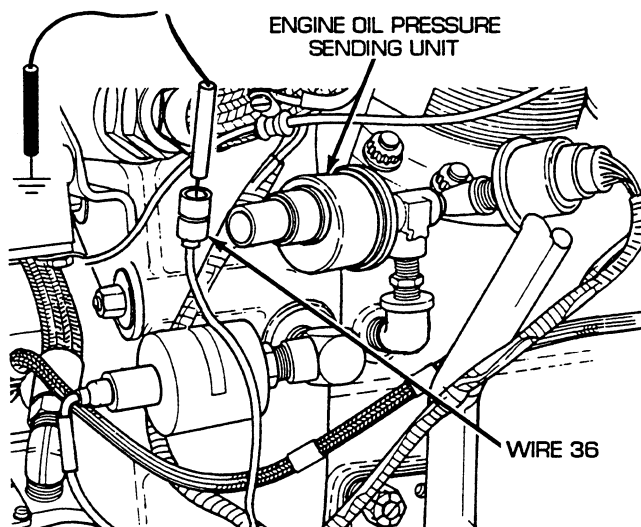

END OF WORK PACKAGE

UNIT MAINTENANCE
RECOVERY VEHICLE, FULL TRACKED: MEDIUM, M88A1
NSN 2350-00-122-6826, EIC AQA
POWER CONTROL LEVER SWITCH TROUBLESHOOTING PROCEDURE

INITIAL SETUP:**Tools and Special Tools**

Tool kit, general mechanic's (item 59, WP 0490 00)

References

WP 0042 00
WP 0159 00
WP 0166 00
WP 0194 00
WP 0195 00
WP 0204 00

References (cont.)

WP 0205 00
WP 0207 00
WP 0208 00
WP 0218 00
WP 0222 00
WP 0223 00
WP 0336 00
TM 9-2350-256-10

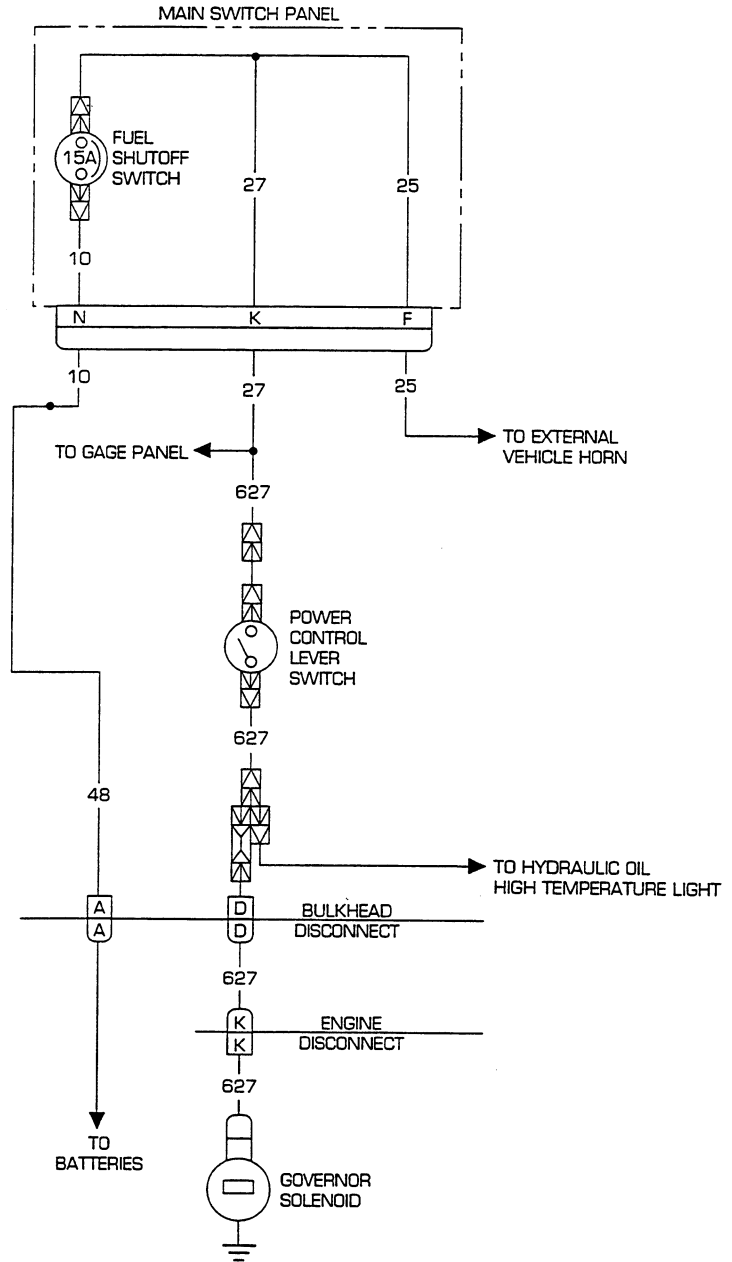
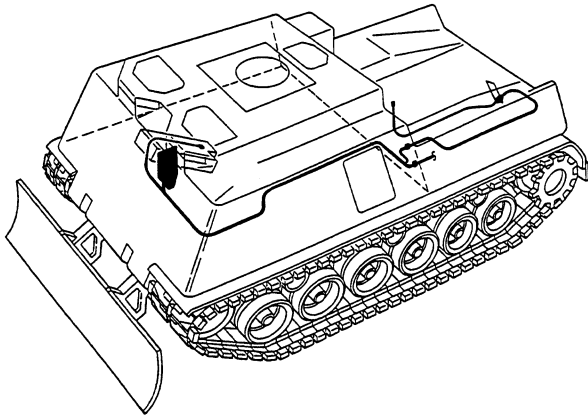

Troubleshooting Procedure

Power Control Lever Switch

Symptom

Power control lever switch malfunctioning.

Malfunction

Engine exceeds 1800 rpm when hydraulic POWER lever is ON. Do steps 1 thru 9.

CORRECTIVE ACTION

WARNING

Remove all jewelry such as rings, dog tags, bracelets, etc. If jewelry contacts a metal surface a direct short may result in instant heating of tools, damage to equipment, and injury or death to personnel.

1. Remove three screws (1), three lockwashers (2), ground lead (3), flat washer (4), and release main switch panel (5) from mounting brackets. Disconnect switch panel to gage panel and miscellaneous switches wiring harness from switch panel. Place red lead of multimeter on pin N of wire 10 and black lead to ground. Turn MASTER switch on and check for voltage. Turn MASTER switch OFF. If voltage is present, go to step 3. If voltage is not present, go to step 2.

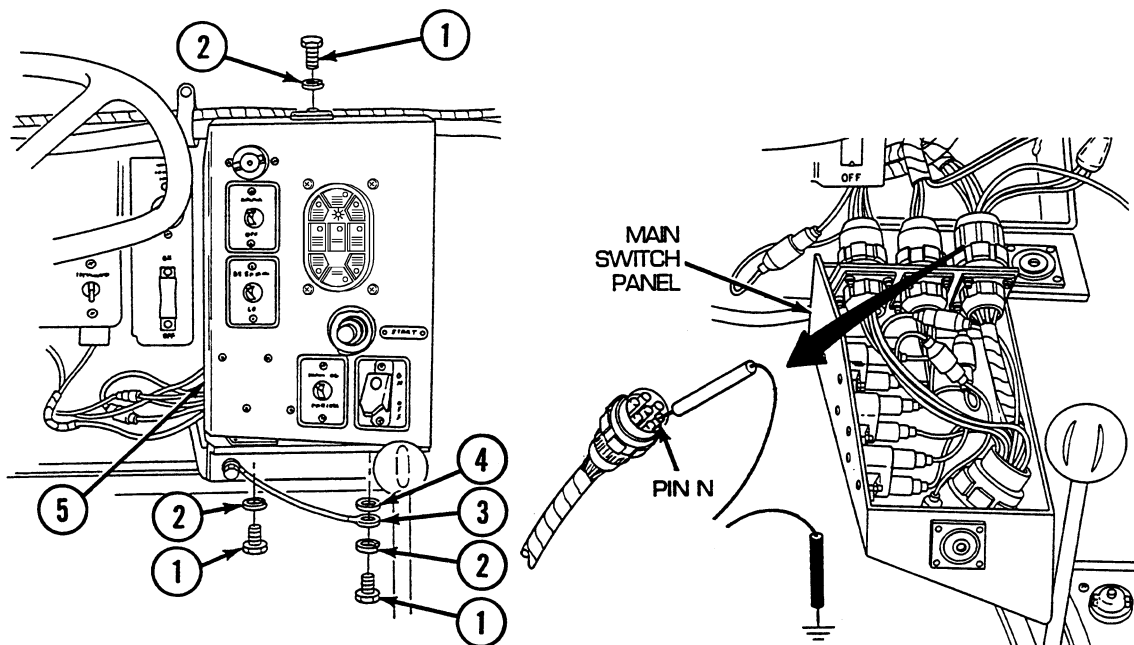

CORRECTIVE ACTION –Continued

2. Reconnect switch panel to gage panel and miscellaneous switches wiring harness. Disconnect switch panel, radio, and bilge pump to bulkhead wiring harness. Place red lead on pin A and black lead to ground and check for voltage. If voltage is present repair/replace switch panel, radio, and bilge pump to bulkhead wiring harness. If voltage is not present, troubleshoot master relay circuit (see WP 0042 00).

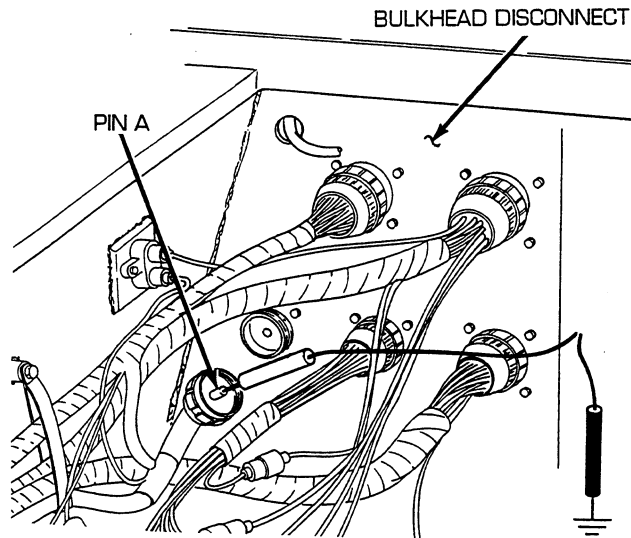

3. Reconnect switch panel to gage panel and miscellaneous switches wiring harness. Disconnect wire 25/27 from 15 A circuit breaker. Place red lead of multimeter on terminal of 15 A circuit breaker and black lead to ground. Turn MASTER switch on and check for voltage. Turn MASTER switch OFF. If voltage is present, go to step 5. If voltage is not present, go to step 4.

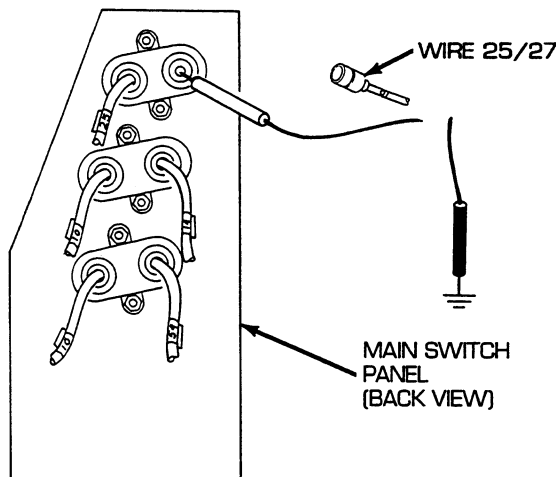

CORRECTIVE ACTION –Continued

4. Reconnect wire 25/27 to 15 A circuit breaker. Disconnect wire 10 from 15 A circuit breaker. Place red lead of multimeter in wire 10 and black lead to ground. Turn MASTER switch on and check for voltage. Turn MASTER switch OFF. If voltage is present, replace circuit breaker (see WP 0159 00). If voltage is not present, repair/replace wire 10 of main lighting and B.O. selector switch wiring harness (see WP 0218 00).

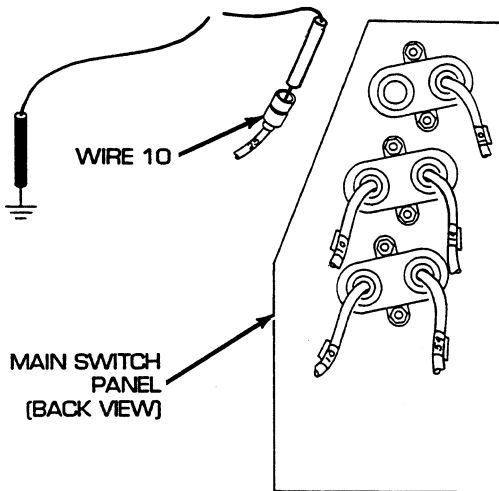

5. Reconnect switch panel to gage panel and miscellaneous switches wiring harness from switch panel. Install main switch panel (5), flat washer (4), ground lead (3), three lockwashers (2) and three screws (1). Disconnect wire 627 of switch panel to gage panel and miscellaneous switches wiring harness from switch panel side of power control lever switch. Place red lead of multimeter in wire 627 and black lead to ground. Turn MASTER switch on and check for voltage. Turn MASTER switch OFF. If voltage is present, go to step 6. If voltage is not present, repair/replace wire 627 of switch panel to gage panel and miscellaneous switches wiring harness (see WP 0204 00 for dual voltage; 0205 00 for single voltage).

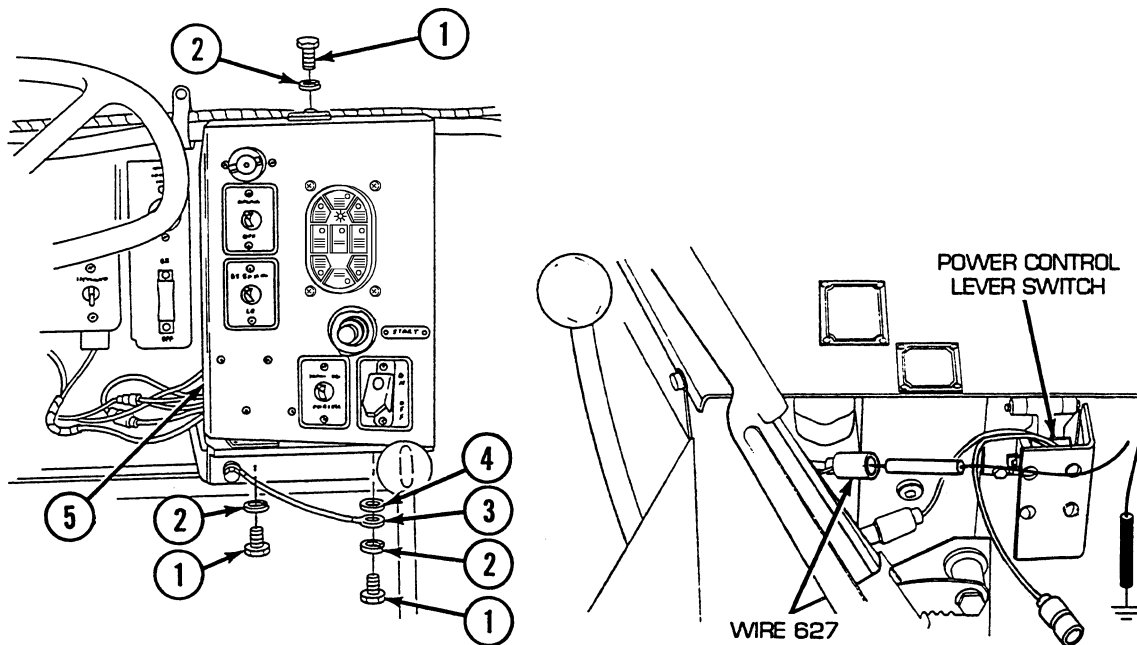

CORRECTIVE ACTION –Continued

6. Reconnect wire 627 of switch panel to gage panel and miscellaneous switches wiring harness to switch panel side of power control switch. Disconnect wire 627 of gage panel to bulkhead wiring harness from power control lever switch. Place red lead of multimeter on terminal of power control lever switch and black lead to ground. Turn MASTER switch on, place POWER lever in the ON position, and check for voltage. Turn MASTER switch OFF. If voltage is present, go to step 7. If voltage is not present, replace power control lever switch (see WP 0166 00).

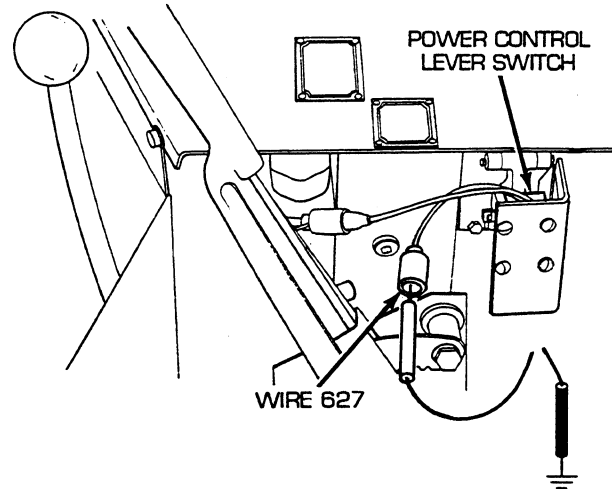

7. Reconnect gage panel to bulkhead wiring harness to power control lever switch. Open air inlet doors (TM 9-2350-256-10). Disconnect bulkhead to engine bracket and rear fuel tank transmitter wiring harness from bulkhead disconnect. Place red lead of multimeter in socket D of wire 627 and black lead to ground. Turn MASTER switch on, place POWER lever in the ON position, and check for voltage. Turn MASTER switch OFF. If voltage is present, go to step 8. If voltage is not present, repair/replace gage panel to bulkhead wiring harness (see WP 0194 00 for dual voltage; 0195 00 for single voltage).

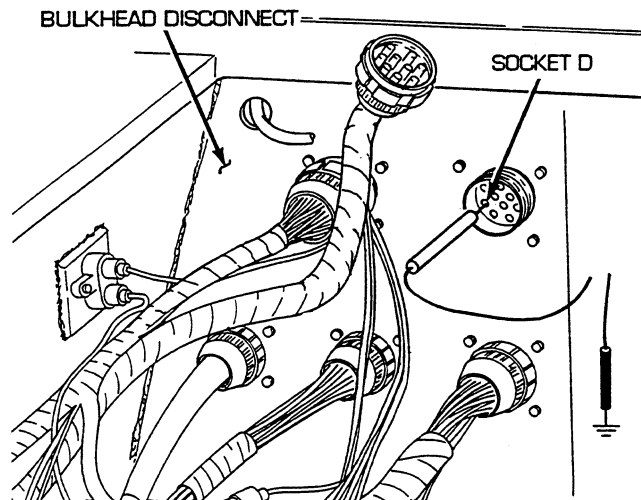

8. Reconnect gage panel to bulkhead wiring harness to bulkhead disconnect. Remove engine deck (see WP 0336 00). Disconnect bulkhead to engine bracket and rear fuel tank transmitter wiring harness from engine disconnect. Place red lead of multimeter in socket K of wire 627 and black lead to ground. Turn MASTER switch on, place POWER lever in the ON position, and check for voltage. Turn MASTER

CORRECTIVE ACTION –Continued

switch OFF. If voltage is present, go to step 9. If voltage is not present, repair/replace wire 627 of bulkhead to engine bracket and rear fuel tank transmitter wiring harness (see WP 0222 00 for dual voltage; 0223 00 for single voltage).

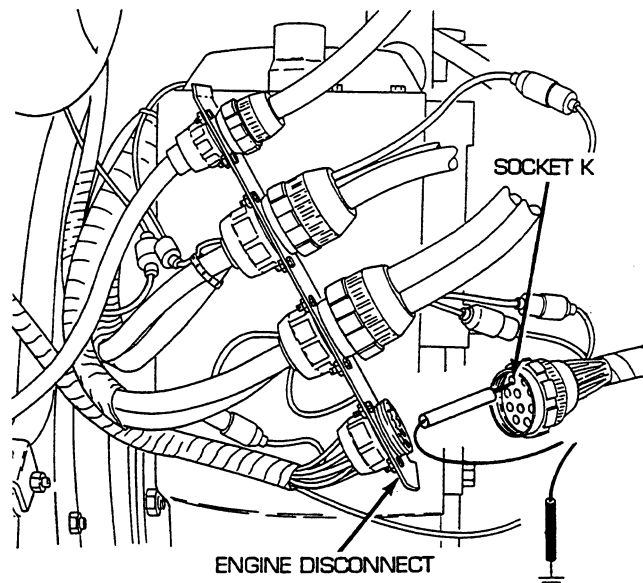

9. Reconnect bulkhead to engine bracket and rear fuel tank transmitter wiring harness to engine disconnect. Disconnect wire 627 from governor solenoid. Place red lead of multimeter on wire 627 and black lead to ground. Turn MASTER switch on, place POWER lever in the ON position, and check for voltage. Turn MASTER switch and POWER lever OFF. If voltage is present, notify Direct Support Maintenance. If voltage is not present, repair/replace wire 627 of engine wiring harness (see WP 0207 00 for dual voltage; 0208 00 for single voltage).

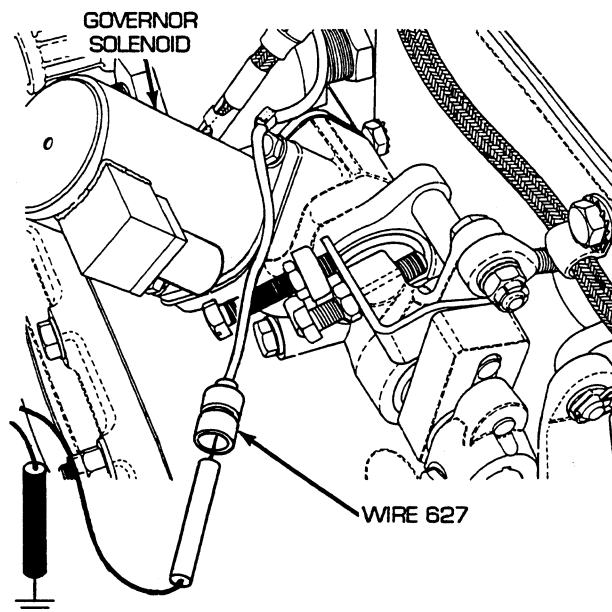

END OF WORK PACKAGE

UNIT MAINTENANCE
RECOVERY VEHICLE, FULL TRACKED: MEDIUM, M88A1
NSN 2350-00-122-6826, EIC AQA

TRANSMISSION OIL TEMPERATURE GAGE TROUBLESHOOTING PROCEDURE

INITIAL SETUP:

Tools and Special Tools

Tool kit, general mechanic's (item 59, WP 0490 00)

References

- WP 0157 00
- WP 0168 00
- WP 0193 00
- WP 0194 00

References (cont.)

- WP 0195 00
- WP 0207 00
- WP 0208 00
- WP 0222 00
- WP 0223 00
- WP 0336 00
- TM 9-2350-256-10

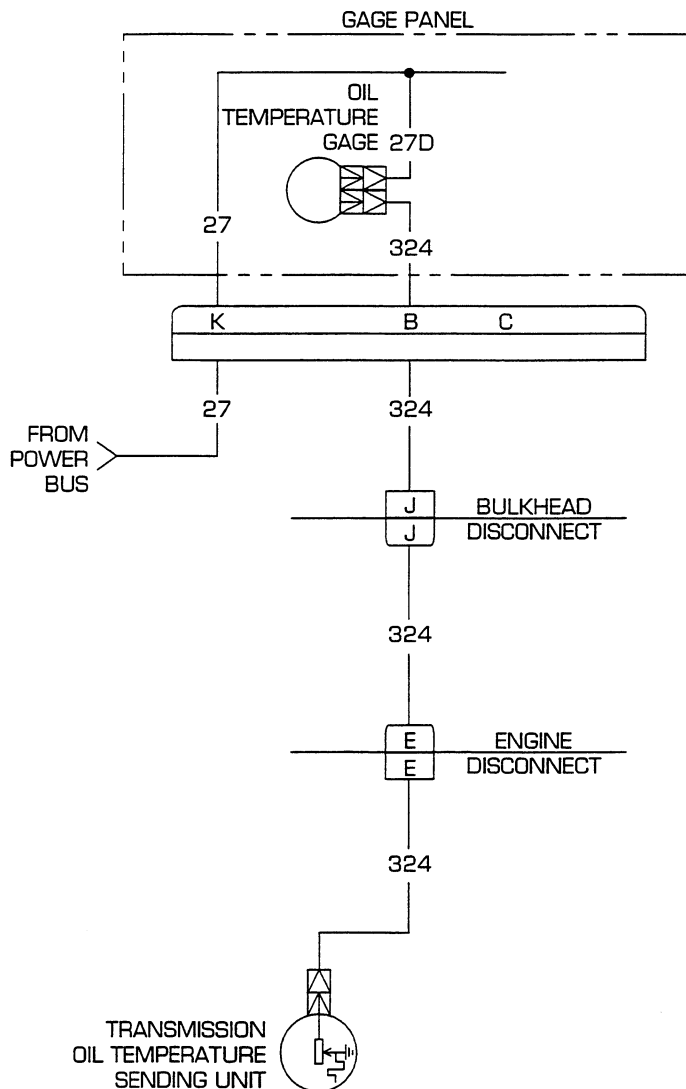
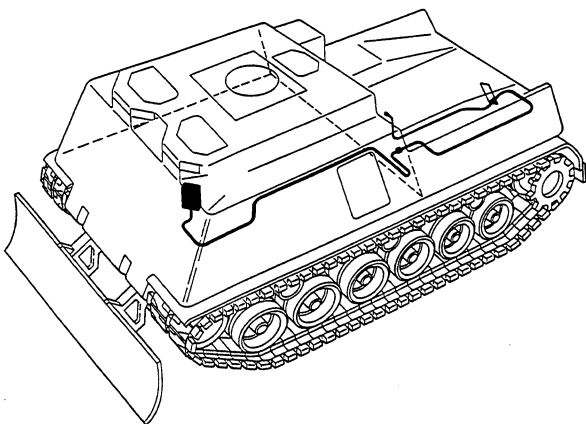

Troubleshooting Procedure

Transmission Oil Temperature Gage

Symptom

Transmission oil temperature gage malfunctioning.

Malfunction

Transmission oil temperature gage does not operate. Do steps 1 thru 7.

CORRECTIVE ACTION

WARNING

Remove all jewelry such as rings, dog tags, bracelets, etc. If jewelry contacts a metal surface a direct short may result in instant heating of tools, damage to equipment, and injury or death to personnel.

1. Remove three screws (1), three lockwashers (2), two screws (3), two lockwashers (4), and ground strap (5) and release gage panel (6). Disconnect gage panel to bulkhead wiring harness from gage panel. Place red lead of multimeter in socket K of wire 27 and black lead to ground. Turn MASTER switch on and check for voltage. Turn MASTER switch OFF. If voltage is present, go to step 2. If voltage is not present, troubleshoot power control lever circuit.

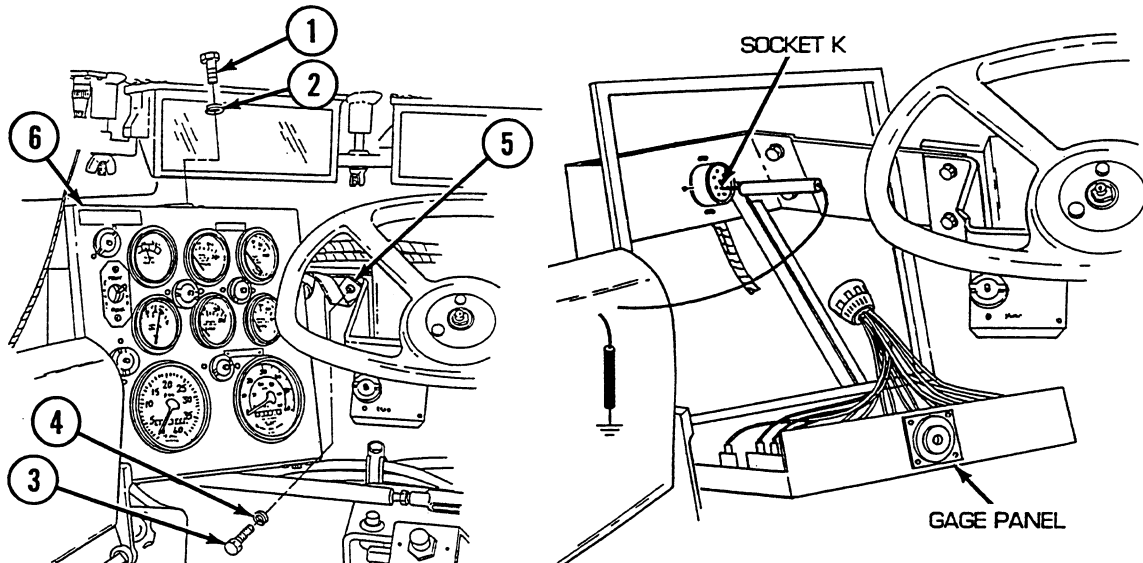

CORRECTIVE ACTION –Continued

2. Reconnect gage panel to bulkhead wiring harness to gage panel. Disconnect wire 27D from transmission oil temperature gage. Place red lead of multimeter in wire 27D and black lead to ground. Turn MASTER switch on and check for voltage. Turn MASTER switch OFF. If voltage is present, go to step 3. If voltage is not present, repair/replace wire 27D of gage panel wiring harness (see WP 0193 00).

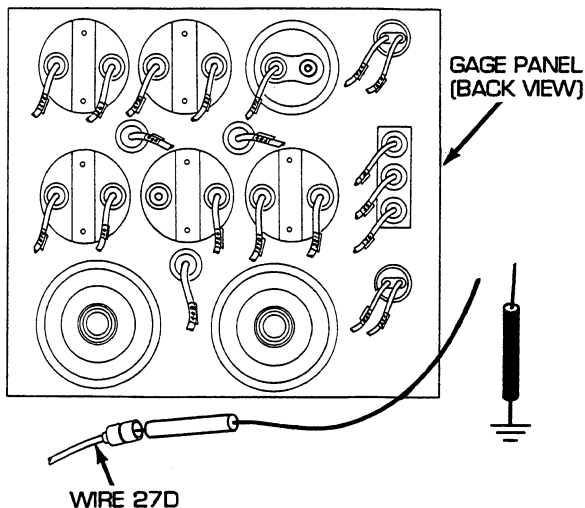

3. Reconnect wire 27D to transmission oil temperature gage. Disconnect wire 324 from transmission oil temperature gage. Turn MASTER switch on and check transmission oil temperature gage for operation. Transmission oil temperature gage should read "0." Ground case of transmission oil temperature gage and check gage for operation. Gage should read full scale. Turn MASTER switch OFF. If transmission oil temperature gage reads correctly, go to step 4. If transmission oil temperature gage fails to read correctly, replace transmission oil temperature gage (see WP 0157 00).

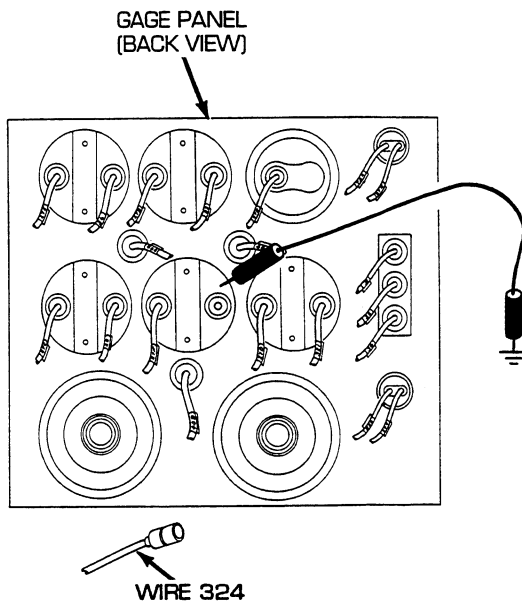

CORRECTIVE ACTION –Continued

4. Disconnect gage panel to bulkhead wiring harness from gage panel. Check wire 324 in gage panel harness for continuity by placing red lead of multimeter on wire 324 and black lead on pin B of wire 324. If continuity is present, go to step 5. If continuity is not present, repair/replace wire 324 of gage panel wiring harness (see WP 0193 00).

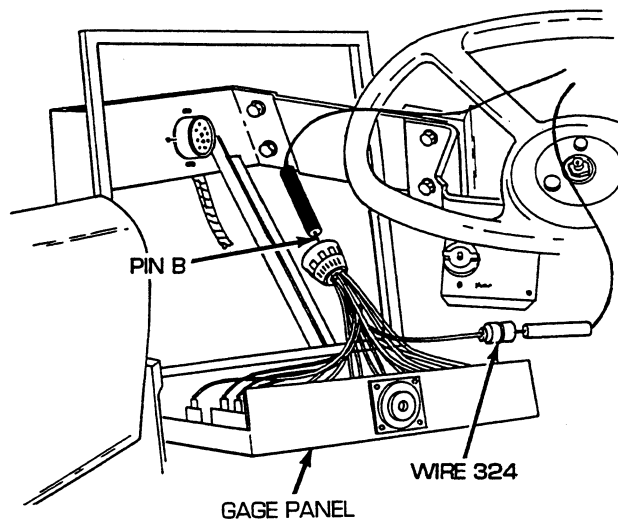

5. Reconnect wire 324 to transmission oil temperature gage and gage panel to bulkhead wiring harness to gage panel. Install ground strap (5), two lockwashers (4), two screws (3), gage panel (6), three lockwashers (2), and three screws (1) to mounting brackets. Open air inlet doors (TM 9-2350-256-10). Disconnect bulkhead to engine bracket and rear fuel tank transmitter wiring harness from bulkhead disconnect. Place red lead of multimeter in socket J of wire 324 and black lead to ground. Turn MASTER switch on and check for voltage. Turn MASTER switch OFF. If voltage is present, go to step 6. If voltage is not present, repair/replace wire 324 of gage panel to bulkhead wiring harness (see WP 0194 00 for dual voltage; 0195 00 for single voltage).

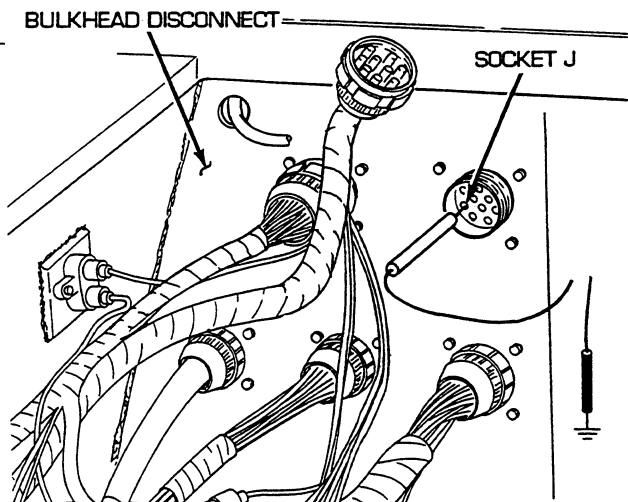
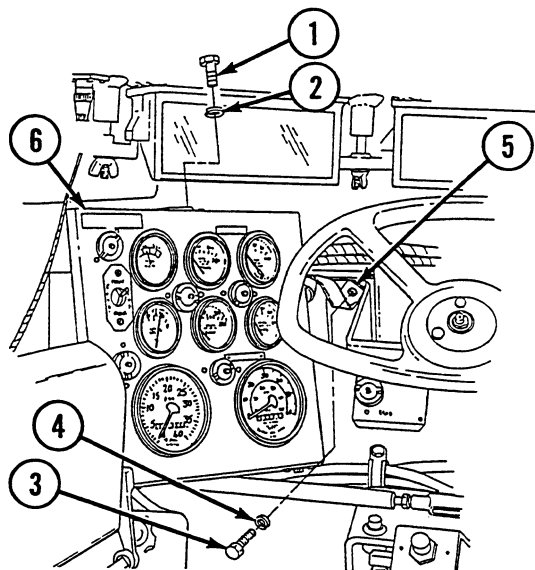

CORRECTIVE ACTION –Continued

6. Reconnect bulkhead to engine bracket and rear fuel tank wiring harness to bulkhead. Remove engine deck (see WP 0336 00). Disconnect bulkhead to engine bracket and rear fuel tank wiring harness from engine disconnect. Place red lead of multimeter in socket E of wire 324 and black lead to ground. Turn MASTER switch on and check for voltage. Turn MASTER switch OFF. If voltage is present, go to step 7. If voltage is not present, repair/replace wire 324 of bulkhead to engine bracket and rear fuel tank wiring harness (see WP 0222 00 for dual voltage; 0223 00 for single voltage).

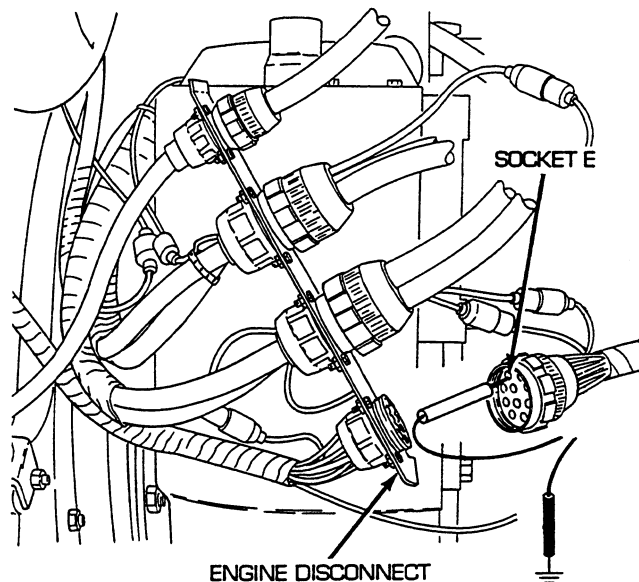

7. Reconnect bulkhead to engine bracket and rear fuel tank wiring harness to engine disconnect. Disconnect wire 324 from transmission oil temperature sending unit. Place red lead of multimeter in wire 324 and black lead to ground. Turn MASTER switch on and check for voltage. Turn MASTER switch OFF. If voltage is present, replace transmission oil temperature sending unit (see WP 0168 00). If voltage is not present, repair/replace wire 324 of engine wiring harness (see WP 0207 00 for dual voltage; 0208 00 for single voltage).

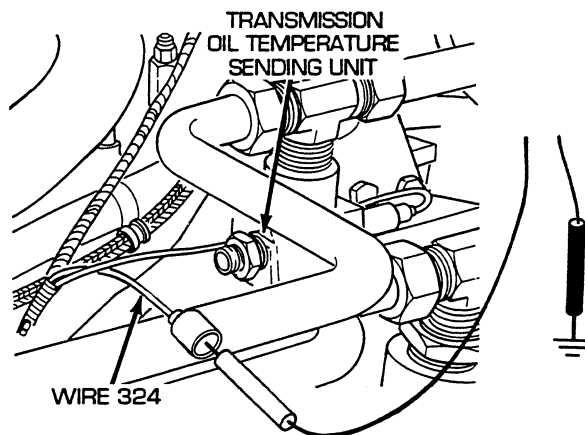
**END OF WORK PACKAGE**

UNIT MAINTENANCE
RECOVERY VEHICLE, FULL TRACKED: MEDIUM, M88A1
NSN 2350-00-122-6826, EIC AQA

TRANSMISSION OIL PRESSURE GAGE TROUBLESHOOTING PROCEDURE

INITIAL SETUP:

Tools and Special Tools

Tool kit, general mechanic's (item 59, WP 0490 00)

References

- WP 0042 00
- WP 0157 00
- WP 0168 00
- WP 0193 00
- WP 0194 00

References (cont.)

- WP 0195 00
- WP 0202 00
- WP 0207 00
- WP 0208 00
- WP 0222 00
- WP 0223 00
- TM 9-2350-256-10

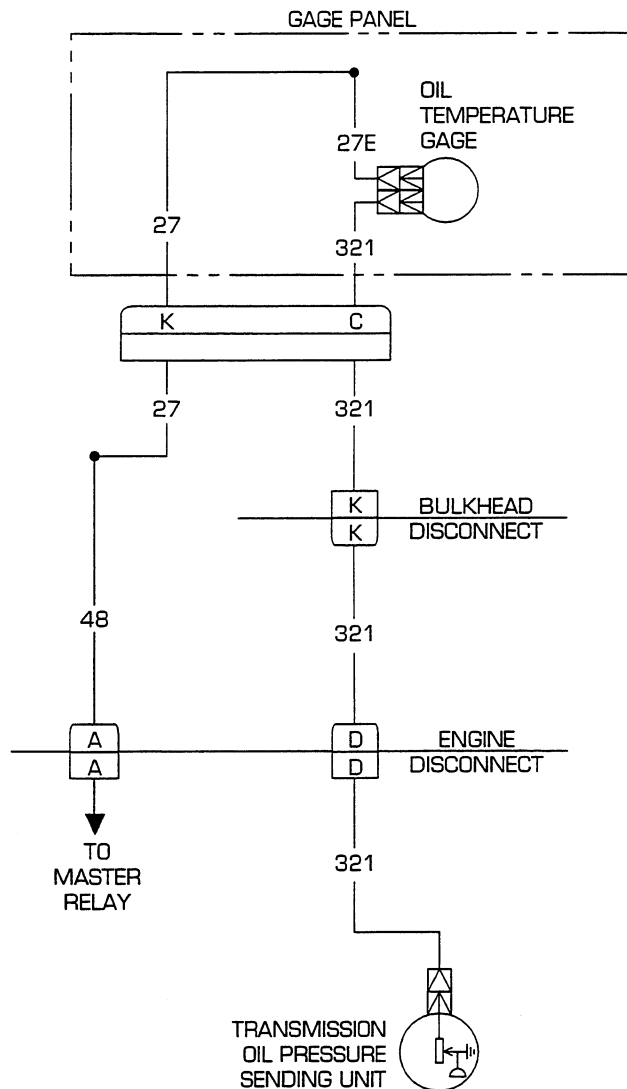
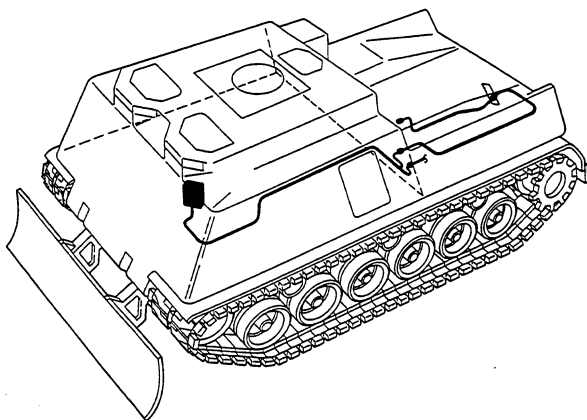

Troubleshooting Procedure

Transmission Oil Pressure Gage

Symptom

Transmission oil pressure gage malfunctioning.

Malfunction

Transmission oil pressure gage does not operate. Do steps 1 thru 8.

CORRECTIVE ACTION

WARNING

Remove all jewelry such as rings, dog tags, bracelets, etc. If jewelry contacts a metal surface a direct short may result in instant heating of tools, damage to equipment, and injury or death to personnel.

1. Remove three screws (1), three lockwashers (2), two screws (3), two lockwashers (4), ground strap (5), and release gage panel (6). Remove gage panel to bulkhead wiring harness from gage panel. Place red lead of multimeter in socket K of wire 27 and black lead to ground. Turn MASTER switch on and check for voltage. Turn MASTER switch OFF. If voltage is present, go to step 2. If voltage is not present, go to step 8.

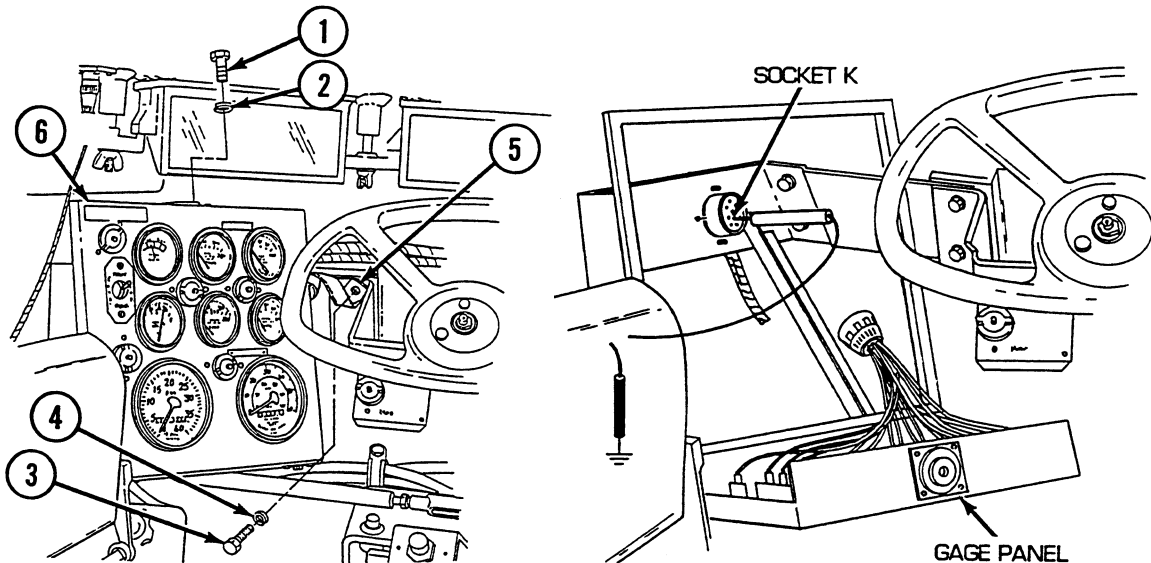

CORRECTIVE ACTION –Continued

2. Reconnect gage panel to bulkhead wiring harness to gage panel. Disconnect wire 27E from transmission oil pressure gage. Place red lead of multimeter on wire 27E and black lead to ground. Turn MASTER switch on and check for voltage. Turn MASTER switch OFF. If voltage is present, go to step 3. If voltage is not present, repair/replace wire 27E of gage panel wiring harness (see WP 0193 00).

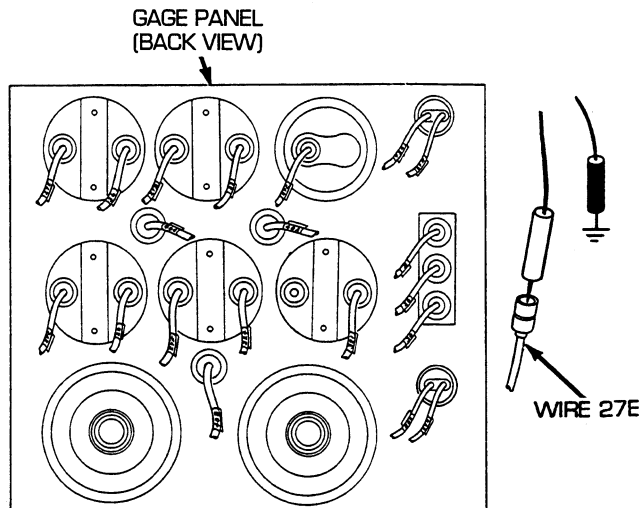

3. Reconnect wire 27E to transmission oil pressure gage. Disconnect wire 321 from transmission oil pressure gage. Turn MASTER switch on and check transmission oil pressure gauge for operation. Transmission oil pressure gauge should read full scale. Ground case of transmission oil pressure gage and check gage for operation. Gage should read "0." Turn MASTER switch OFF. If transmission oil pressure gauge reads correctly, go to step 4. If transmission oil pressure gauge fails to read correctly, replace transmission oil pressure gauge (see WP 0157 00).

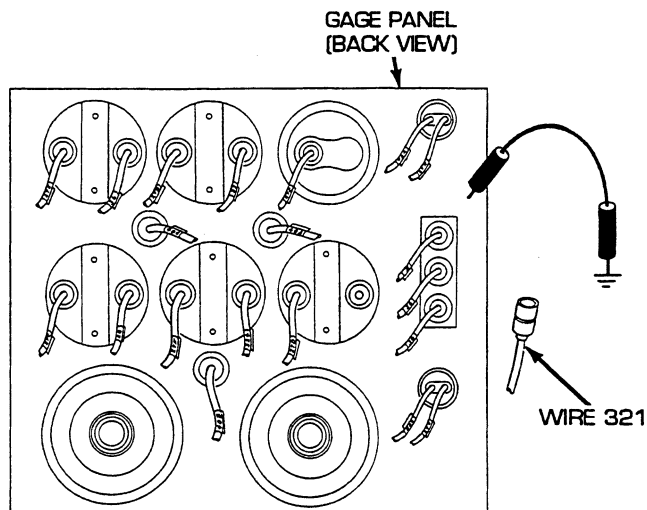

CORRECTIVE ACTION –Continued

4. Disconnect gage panel to bulkhead wiring harness from gage panel. Check wire 321 in gage panel harness for continuity by placing red lead of multimeter on wire 321 and black lead on pin C. If continuity is present, go to step 5. If continuity is not present, repair/replace wire 321 of gage panel wiring harness (see WP 193 00).

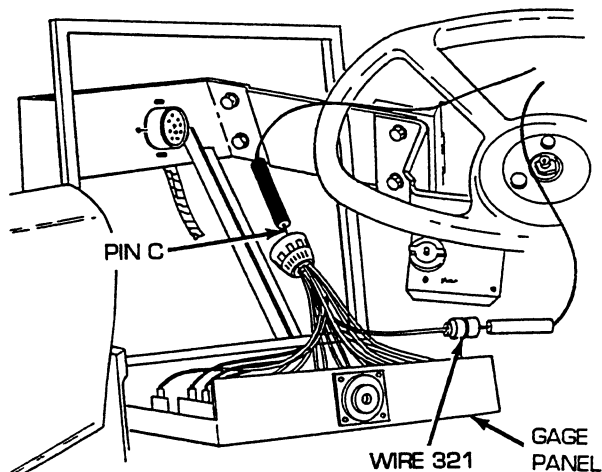

5. Reconnect wire 321 to transmission oil pressure gage and bulkhead wiring harness to gage panel. Install ground strap (5), two lockwashers (4), two screws (3), gage panel (6), three lockwashers (2), and three screws (1). Open air inlet doors (TM 9-2350-256-10). Disconnect bulkhead to engine bracket and rear fuel tank wiring harness from bulkhead disconnect. Place red lead of multimeter in socket K of wire 321 and black lead to ground. Turn MASTER switch on and check for voltage. Turn MASTER switch OFF. If voltage is present, go to step 6. If voltage is not present, repair/replace wire 321 of gage panel to bulkhead wiring harness (see WP 0194 00 for dual voltage; 0195 00 for single voltage).

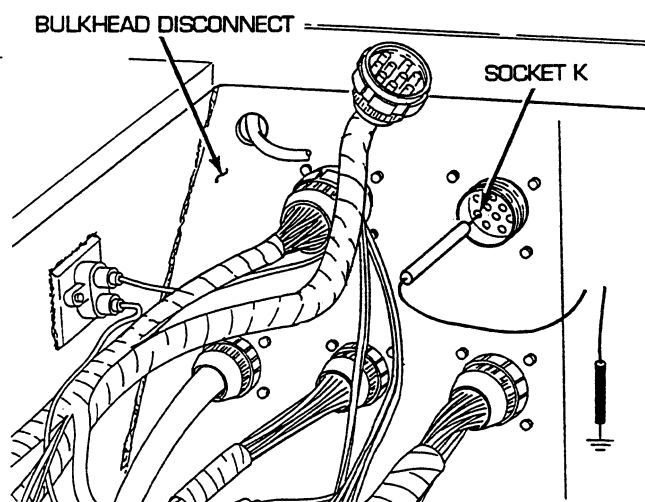
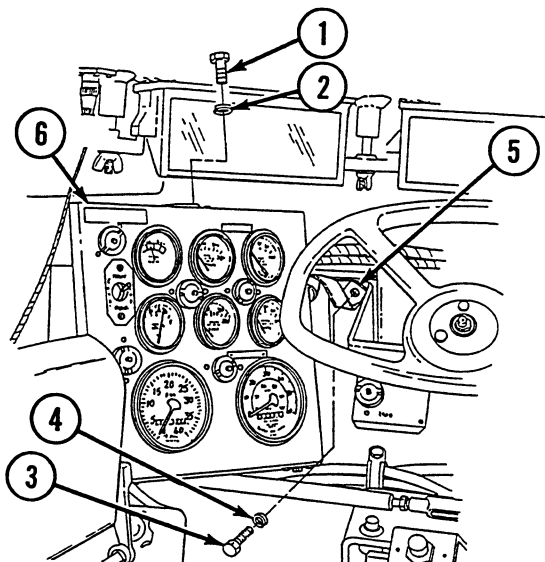

CORRECTIVE ACTION –Continued

6. Reconnect bulkhead to engine bracket and rear fuel tank transmitter wiring harness to bulkhead and disconnect from engine disconnect. Place red lead of multimeter in socket D of wire 321 and black lead to ground. Turn MASTER switch on and check for voltage. Turn MASTER switch OFF. If voltage is present, go to step 7. If voltage is not present, repair/replace wire 321 of bulkhead to engine bracket and rear fuel tank wiring harness (see WP 0222 00 for dual voltage; 0223 00 for single voltage).

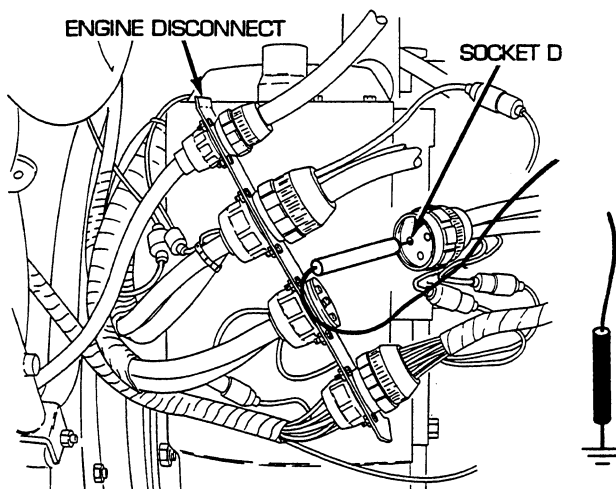

7. Reconnect bulkhead to engine bracket and rear fuel tank wiring harness to engine disconnect. Disconnect wire 321 from transmission oil pressure sending unit. Place red lead of multimeter on wire 321 and black lead to ground. Turn MASTER switch on and check for voltage. Turn MASTER switch OFF. If voltage is present, replace transmission oil pressure sending unit (see WP 0168 00). If voltage is not present, repair/replace wire 321 of engine wiring harness (see WP 0207 00 for dual voltage; 0208 00 for single voltage).

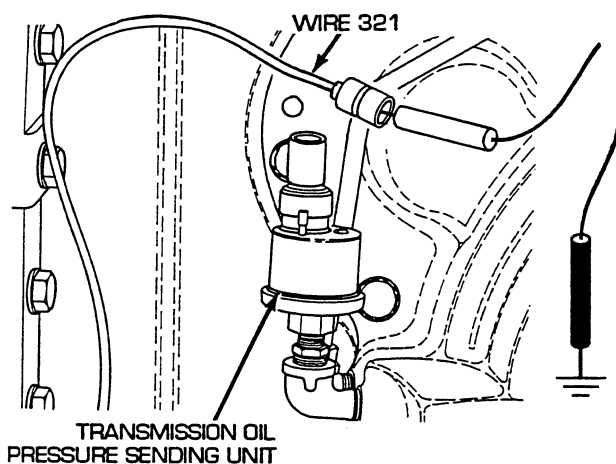

CORRECTIVE ACTION –Continued

8. Install ground strap (5), two lockwashers (4), two screws (3), gage panel (6), three lockwashers (2), and three screws (1). Open air inlet doors (TM 9-2350-256-10). Disconnect wire 48 pin A from bulkhead to master relay wiring harness. Place red multimeter lead in socket and black lead to ground. Turn MASTER switch on and check for voltage. If voltage is present repair or replace switch panel, radio, and bilge pump to bulkhead wiring harness (see WP 0202 00). If voltage is not present, troubleshoot master relay circuit (see WP 0042 00).

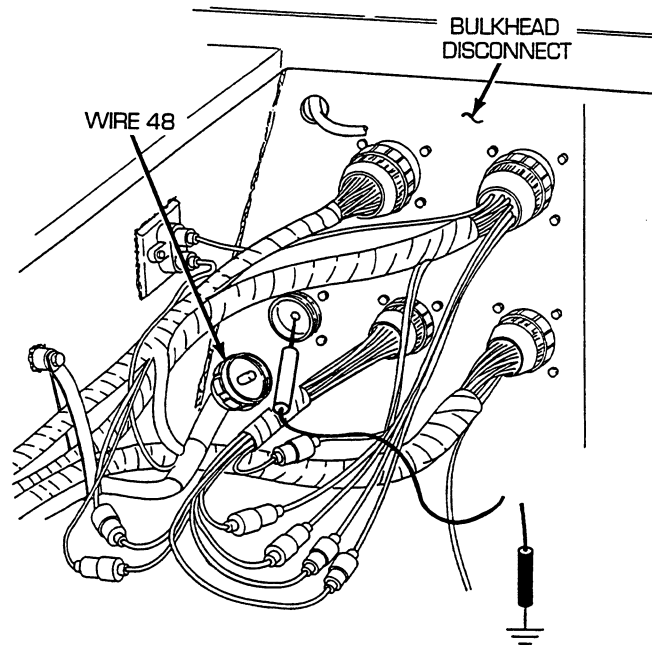
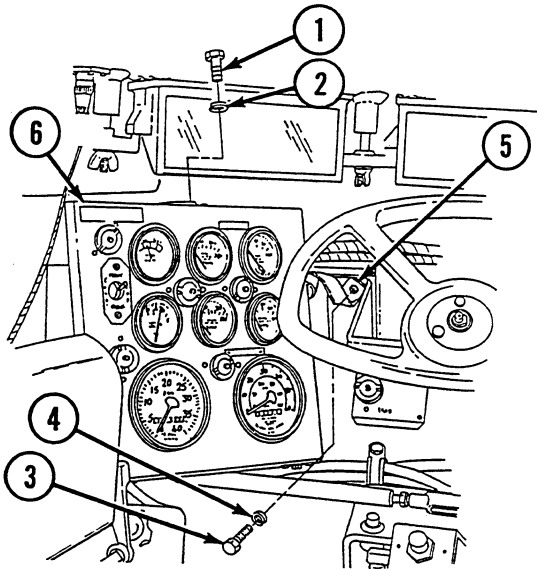
**END OF WORK PACKAGE**

UNIT MAINTENANCE
RECOVERY VEHICLE, FULL TRACKED: MEDIUM, M88A1
NSN 2350-00-122-6826, EIC AQA

ENGINE GENERATOR (DUAL VOLTAGE) TROUBLESHOOTING PROCEDURE

INITIAL SETUP:

Tools and Special Tools

Tool kit, general mechanic's (item 59, WP 0490 00)

References

- WP 0098 00
- WP 0150 00
- WP 0154 00
- WP 0158 00
- WP 0185 00

References (cont.)

- WP 0192 00
- WP 0196 00
- WP 0221 00
- WP 0222 00
- WP 0224 00
- WP 0233 00
- WP 0336 00
- TM 9-2350-256-10

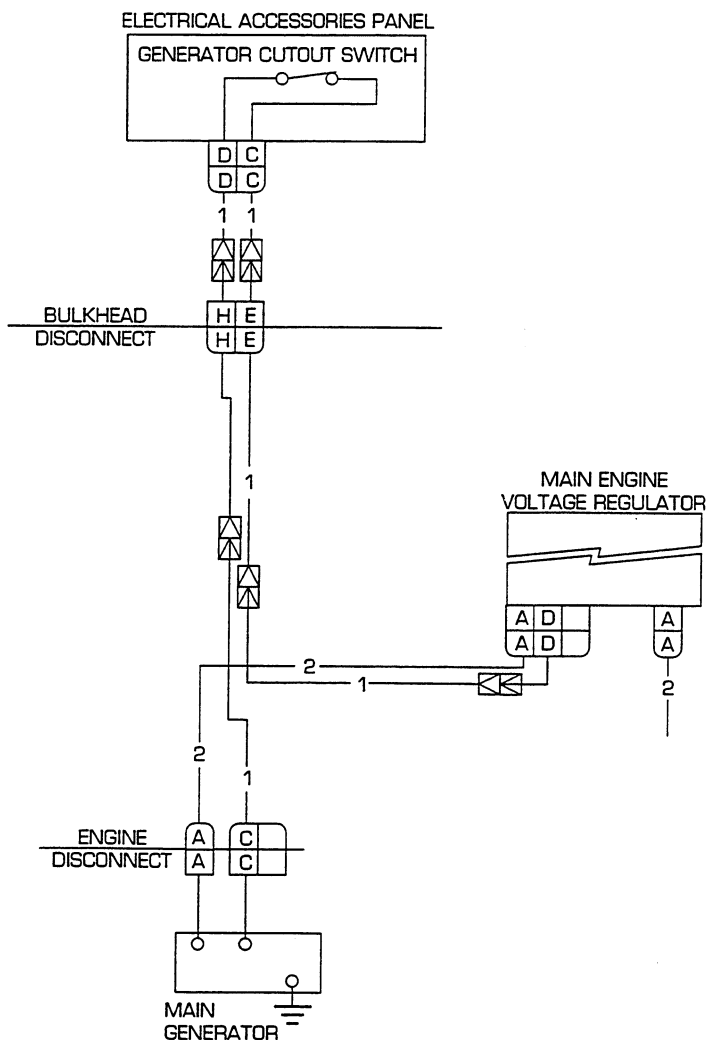
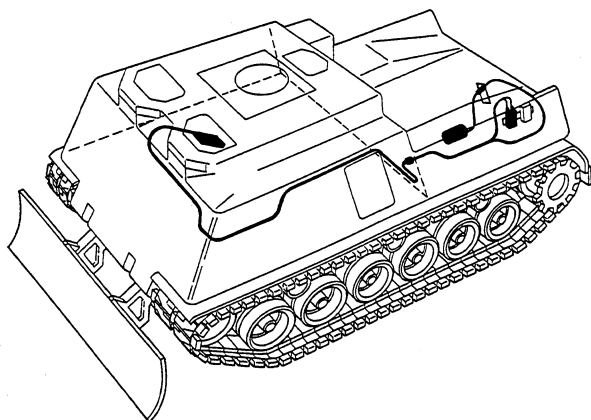

Troubleshooting Procedure

Engine Generator (Dual Voltage)

Symptom

Engine generator (dual voltage) malfunctioning.

Malfunction

Generator indicator reads in yellow or lower red region with engine running and generator cutout switch closed. Do step 1.

Generator cutout switch does not operate. Do steps 3 thru 11.

CORRECTIVE ACTION

WARNING

Remove all jewelry such as rings, dog tags, bracelets, etc. If jewelry contacts a metal surface a direct short may result in instant heating of tools, damage to equipment, and injury or death to personnel.

1. Raise boom all the way up (TM 9-2350-256-10). Open air inlet door (TM 9-2350-256-10). Remove screw (1), nut (2), and bracket (3). Disconnect batteries to master relay, voltage regulators, slave receptacle, and engine disconnect wiring harness from engine regulator. Place red lead of multimeter on pin A of wire 2 and black lead to ground. Turn MASTER switch on and check for voltage. Turn MASTER switch OFF. If voltage is not present, troubleshoot battery circuit. If voltage is present, go to step 2.

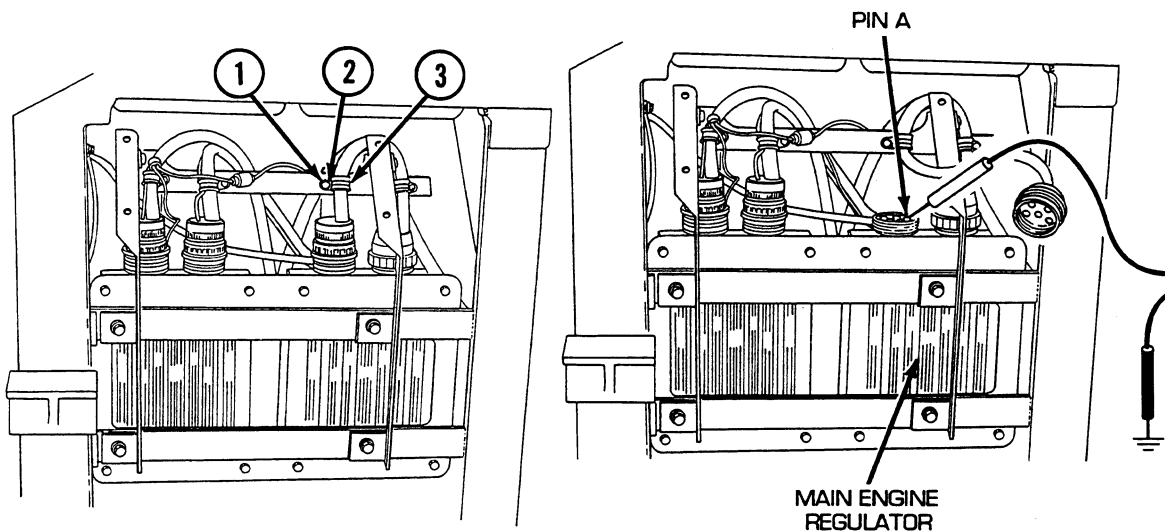

CORRECTIVE ACTION –Continued

2. Place red lead of multimeter on pin A of voltage regulator and black lead to ground. Turn MASTER switch on, start engine, open generator cutout switch and check for voltage. Turn engine and MASTER switch OFF, and close generator cutout switch. If voltage is present, go to step 7. If voltage is not present, replace main engine regulator (see WP 0154 00).

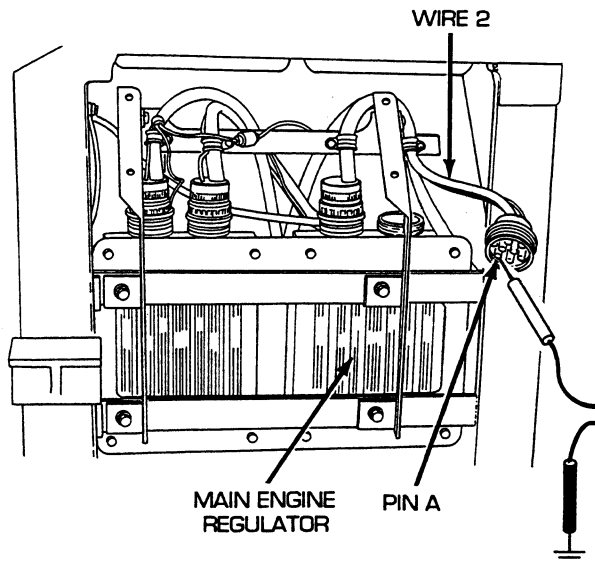

3. Disconnect electrical accessories panel wiring harness from electrical accessories panel. Place red lead of multimeter in socket C of wire 1 and black lead to ground. Turn MASTER switch on and check for voltage. Turn MASTER switch OFF. If voltage is present, go to step 4. If voltage is not present, go to step 5.

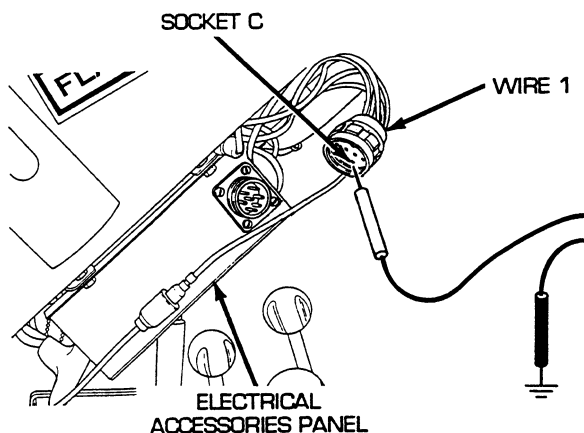

CORRECTIVE ACTION –Continued

4. Disconnect wire 1 (from socket C) of electrical accessories panel wiring harness from switch panel to neutral safety to bulkhead wiring harness. Place red lead of multimeter on male connector of wire 1 and black lead to ground. Turn MASTER switch on, start engine, open generator cutout switch and check for voltage. Turn engine and MASTER switch OFF, and close generator cutout switch. If voltage is present, repair/replace wire 1 of electrical accessories panel wiring harness (see WP 0196 00). If voltage is not present, go to step 6.

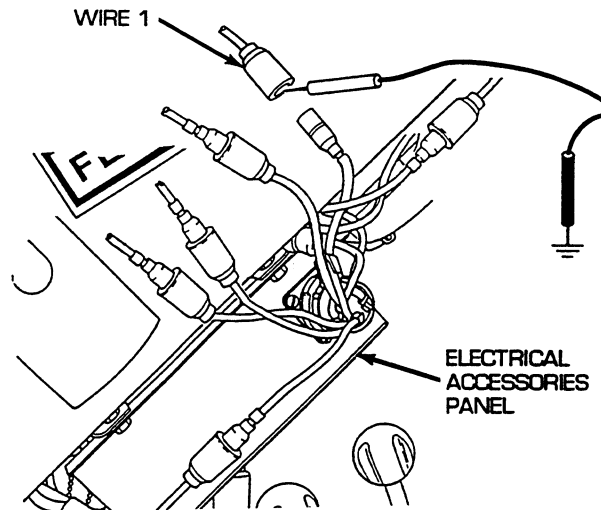

5. Reconnect bulkhead to engine wiring harness and starter relay wiring harness to bulkhead disconnect. Disconnect wire 1 of bulkhead to engine bracket and rear fuel tank transmitter wiring harness (from engine voltage regulator) from bulkhead to engine wiring harness and starter relay wiring harness. Place red lead of multimeter on male connector of wire 1 and black lead to ground. Turn MASTER switch on, start engine, open generator cutout switch and check for voltage. Turn engine and MASTER switch OFF and close generator cutout switch. If voltage is present, repair/replace wire 1 of bulkhead to engine wiring harness and starter relay wiring harness (see WP 0221 00). If voltage is not present, go to step 6.

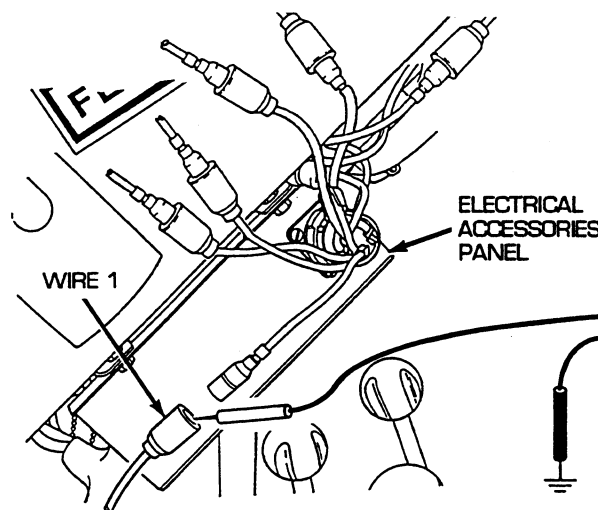

CORRECTIVE ACTION –Continued

6. Reconnect wire 1 of bulkhead to engine bracket and rear fuel tank transmitter wiring harness to the bulkhead to engine wiring harness and starter relay wiring harness. Disconnect wire 1 of bulkhead to engine bracket and rear fuel tank transmitter wiring harness from bulkhead to APU, master relay, and rigger's lights wiring harness. Place red lead of multimeter on male connector of wire 1 and black lead to ground. Turn MASTER switch on, start engine, open generator cutout switch and check for voltage. Turn engine and MASTER switch OFF, and close generator cutout switch. If voltage is present, repair/replace wire 1 of bulkhead to APU, master relay, and rigger's lights wiring harness (see WP 0224 00). If voltage is not present, go to step 9.

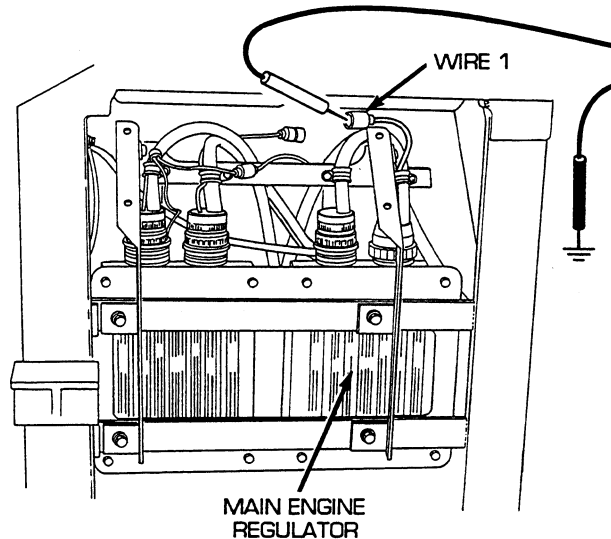

7. Remove engine deck (see WP 0336 00). Reconnect engine voltage regulator to engine disconnect wiring harness to engine voltage regulator. Disconnect generator power lead assembly from engine disconnect. Place red lead of multimeter in socket A of wire 2 and black lead to ground. Turn MASTER switch on, start engine, open generator cutout switch and check for voltage. Turn engine and MASTER switch OFF, and close generator cutout switch. If voltage is not present, repair/replace wire 2 of engine voltage regulator to engine disconnect wiring harness (see WP 0192 00). If voltage is present, go to step 8.

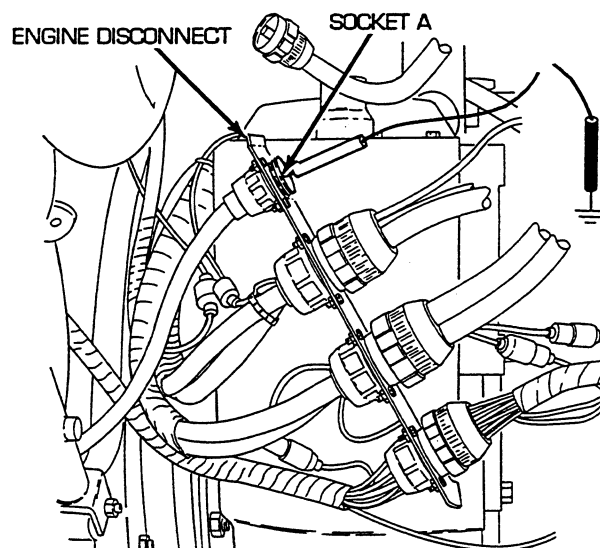

CORRECTIVE ACTION –Continued

8. Remove powerplant (see WP 0098 00). Disconnect wire 2 from generator positive terminal B. Install groundhop, from positive terminal B to suitable ground. Turn MASTER switch on, start engine, open generator cutout switch. If voltage is not present, repair/replace wire 2 of generator power lead assembly (see WP 0185 00). Reconnect wire 2 to positive terminal B. If voltage is present, replace engine generator (see WP 0150 00).

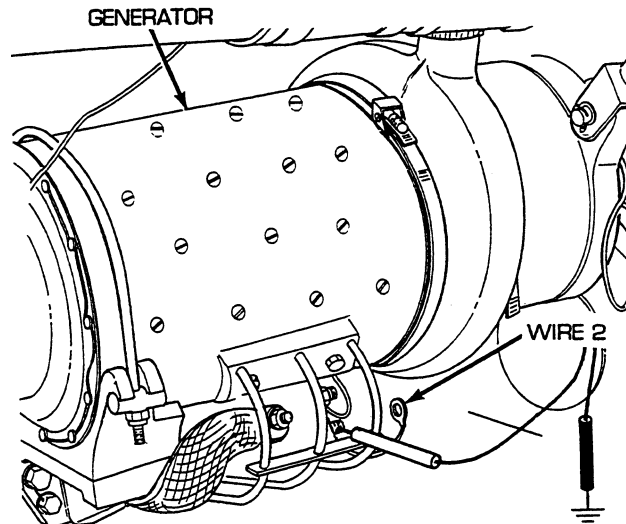

9. Reconnect bulkhead to engine wiring harness and starter relay wiring harness to bulkhead disconnect. Remove engine deck (see WP 0336 00). Disconnect bulkhead to engine bracket and rear fuel tank transmitter wiring harness from engine disconnect. Place red lead of multimeter in socket C of wire 1 and black lead to ground. Turn MASTER switch on, start engine, open generator cutout switch and check for voltage. Turn engine and MASTER switch OFF and close generator cutout switch. If voltage is present, repair/replace wire 1 of bulkhead to engine bracket and rear fuel tank transmitter wiring harness (see WP 0222 00). If voltage is not present, go to step 10.

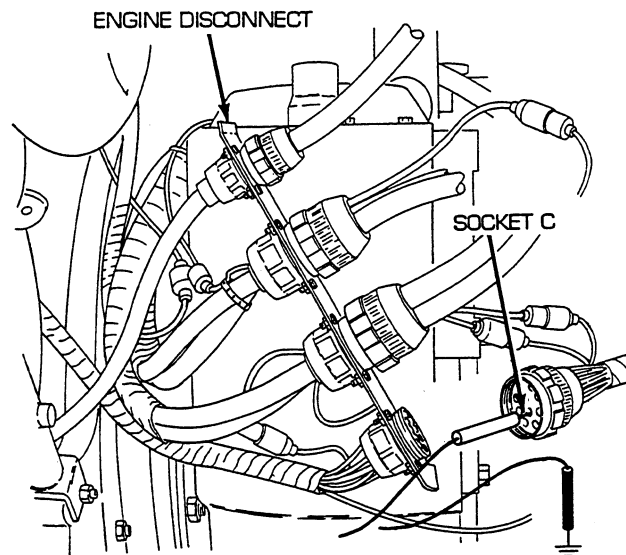

CORRECTIVE ACTION –Continued

10. Remove four screws (4), four lockwashers (5), and release accessories panel (6). Disconnect wire 1 (from socket D) from generator cutout switch. Place red lead of multimeter in wire 1 and black lead to ground. Turn MASTER switch on and check for voltage. Turn MASTER switch OFF. If voltage is present, go to step 11. If voltage is not present repair/replace wire 1 of bilge pump main power wiring harness from socket D (see WP 0233 00).

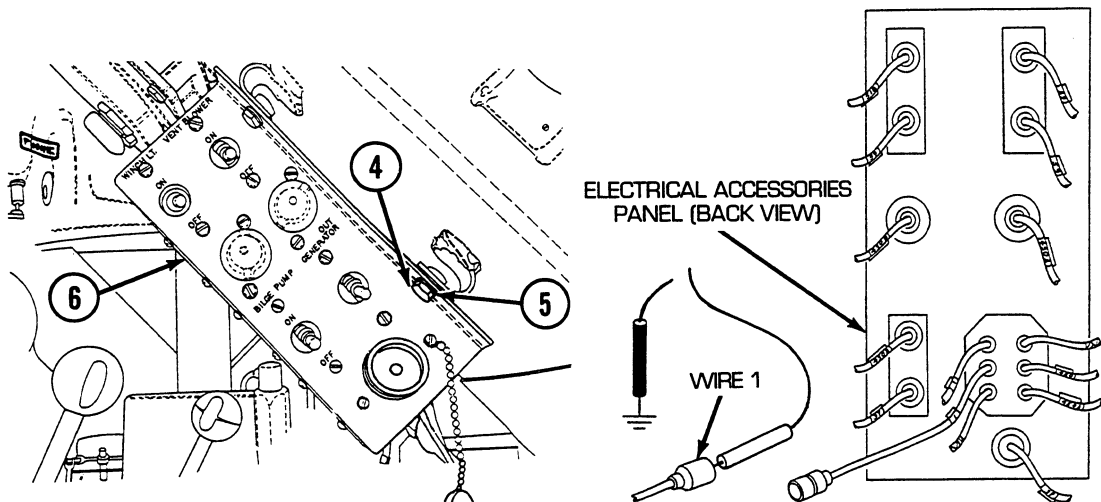

11. Reconnect wire 1 (from socket D) to generator cutout switch. Disconnect wire 1 (from socket C) from generator cutout switch. Place red lead of multimeter on generator cutout switch and black lead to ground. Turn MASTER switch on, open generator cutout switch and check for voltage. Turn MASTER switch OFF, close generator cutout switch. If voltage is present, repair/replace wire 1 of bilge pump main power wiring harness (see WP 0233 00). If voltage is not present, replace generator cutout switch (see WP 0158 00).

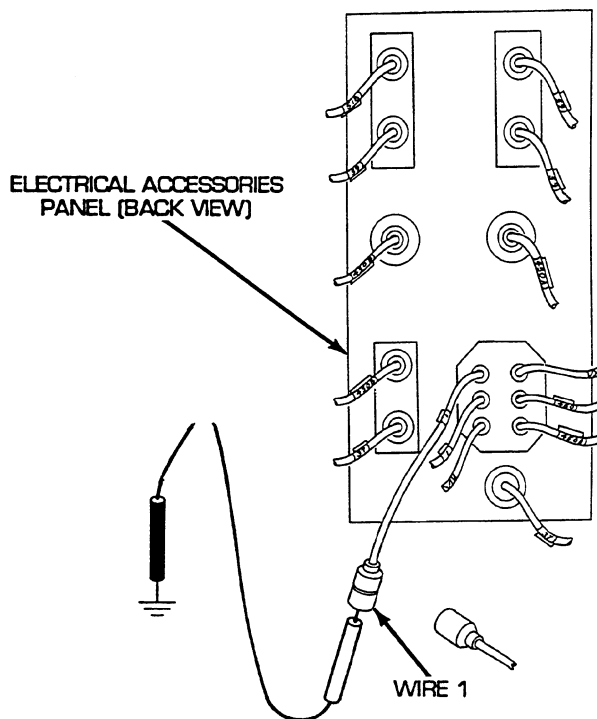

END OF WORK PACKAGE

UNIT MAINTENANCE
RECOVERY VEHICLE, FULL TRACKED: MEDIUM, M88A1
NSN 2350-00-122-6826, EIC AQA

ENGINE GENERATOR (SINGLE VOLTAGE) TROUBLESHOOTING PROCEDURE

INITIAL SETUP:**Tools and Special Tools**

Tool kit, general mechanic's (item 59, WP 0490 00)

References

WP 0098 00
WP 0135 00
WP 0150 00
WP 0151 00
WP 0158 00
WP 0162 00
WP 0185 00

References (cont.)

WP 0196 00
WP 0203 00
WP 0211 00
WP 0221 00
WP 0223 00
WP 0230 00
WP 0233 00
WP 0336 00
TM 9-2350-256-10

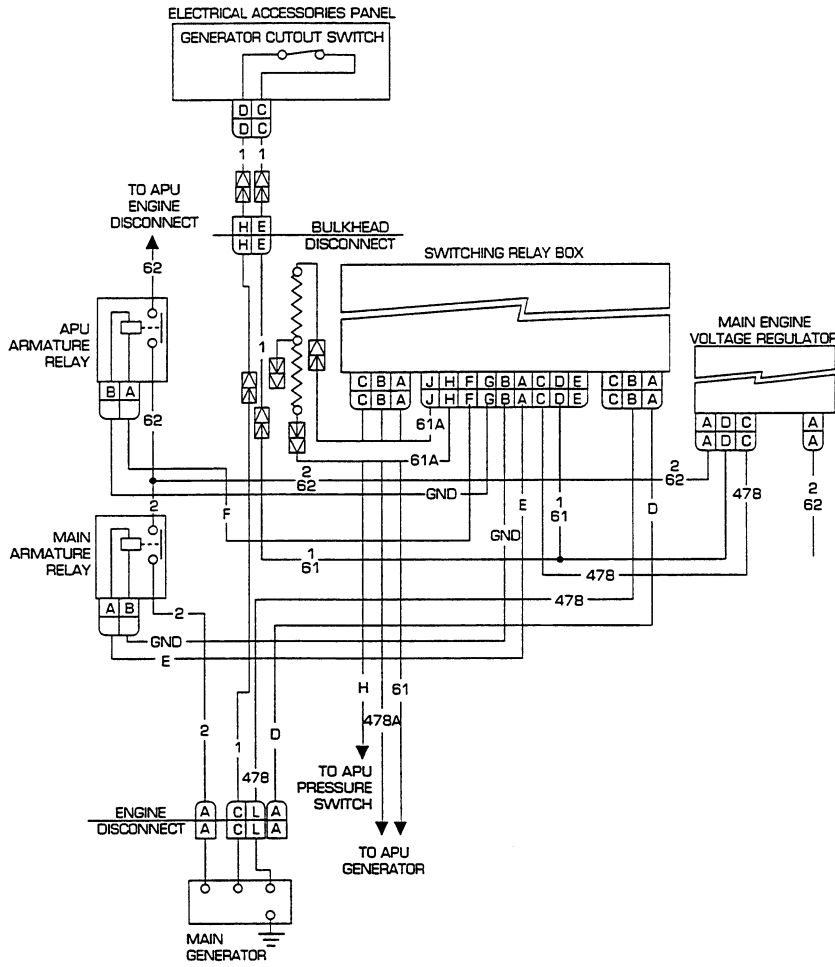
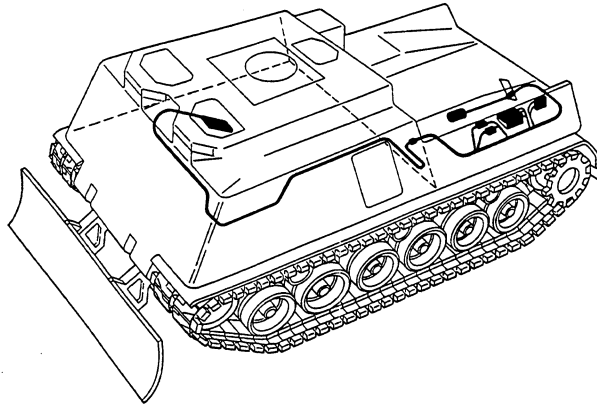

Troubleshooting Procedure

Engine Generator (Single Voltage)

Symptom

Engine generator (single voltage) malfunctioning.

Malfunction

Generator indicator reads in yellow or lower red region with engine running and generator cutout switch closed. Do steps 1 thru 19.

Generator cutout switch does not operate. Do steps 9 through 19.

CORRECTIVE ACTION

WARNING

Remove all jewelry such as rings, dog tags, bracelets, etc. If jewelry contacts a metal surface a direct short may result in instant heating of tools, damage to equipment, and injury or death to personnel.

1. Open air inlet doors (TM 9-2350-256-10). Disconnect batteries to master relay, voltage regulator, slave receptacle, and engine disconnect wiring harness from engine regulator. Place red lead of multimeter on pin A of wire 2/62 and black lead to ground. Turn MASTER switch on and check for voltage. Turn MASTER switch OFF. If voltage is present, go to step 2. If voltage is not present, troubleshoot battery circuit.

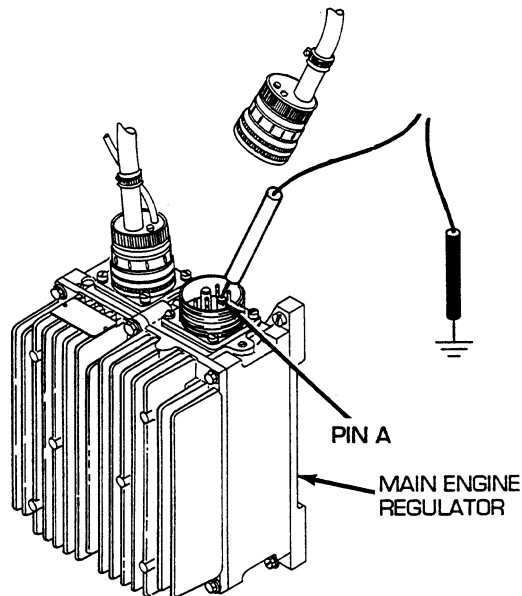

CORRECTIVE ACTION –Continued

2. Reconnect batteries to master relay, voltage regulator, slave receptacle, and engine disconnect wiring harness to engine regulator. Disconnect APU and engine armature relays to voltage regulator wiring harness from engine regulator. Place red lead of multimeter on pin D of wire 1/61 and black lead to ground. Turn MASTER switch on, start engine and close generator output switch and check for voltage. Turn engine and MASTER switch OFF, and open generator output switch. If voltage is present, go to step 9. If voltage is not present, go to step 3.

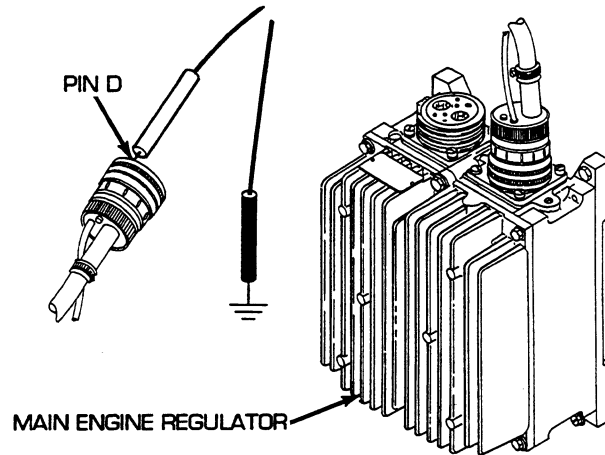

3. Place red lead of multimeter on pin A of wire 2/62 and black lead to ground. Turn MASTER switch on, start engine, open generator cutout switch and check for voltage. Turn engine and MASTER switch OFF, and close generator cutout switch. If voltage is not present, replace engine regulator (see WP 0135 00). If voltage is present, go to step 4.

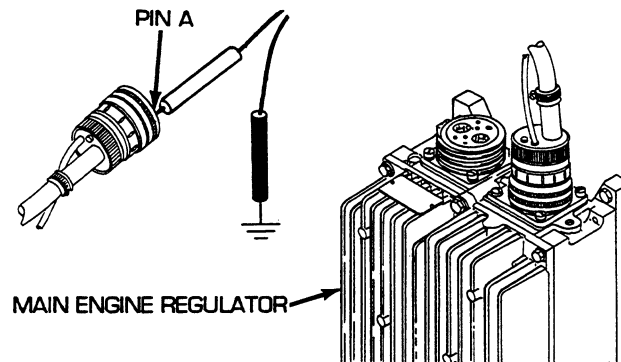

CORRECTIVE ACTION –Continued

4. Reconnect APU and engine generator relays to voltage regulator wiring harness to engine regulator. Disconnect wire 2 of APU and engine generator relays to voltage regulator wiring harness from engine generator relay. Place red lead of multimeter on terminal of engine generator relay and black lead to ground. Turn MASTER switch on, start engine, open generator cutout switch and check for voltage. Turn engine and MASTER switch OFF, and close generator cutout switch. If voltage is present, go to step 6. If voltage is not present, go to step 5.

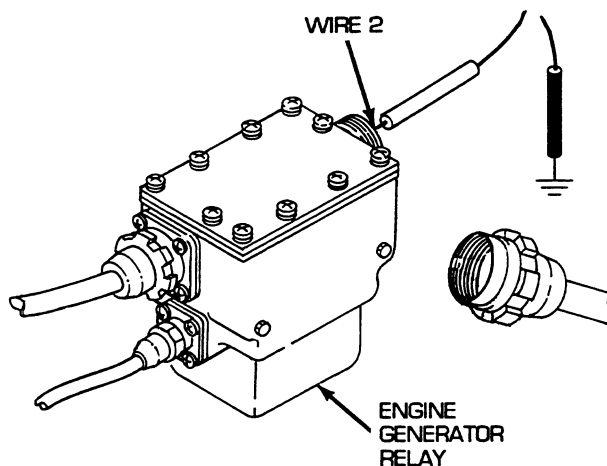

5. Reconnect wire 2 of APU and engine generator relays to voltage regulator wiring harness to engine generator relay. Disconnect wire 62/2 of APU and engine generator relays to voltage regulator wiring harness from APU generator relay. Place red lead of multimeter on wire 62/2 and black lead to ground. Turn MASTER and APU generator switches on, and check for voltage. Turn APU generator and MASTER switches OFF. If voltage is not present, repair/replace wire 62/2 of APU and engine generator relays to voltage regulator wiring harness. If voltage is present, replace master relay (see WP 0151 00).

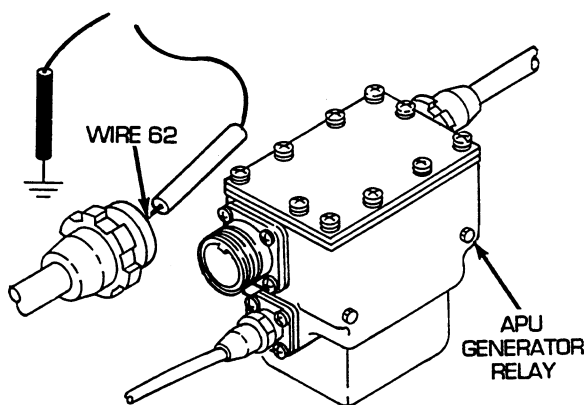

CORRECTIVE ACTION –Continued

6. Reconnect wire 2 of engine disconnect to engine generator relay lead to engine generator relay. Remove engine deck (see WP 0336 00). Disconnect generator power lead assembly from engine disconnect. Place red lead of multimeter in socket A of wire 2 and black lead to ground. Turn MASTER switch on, start engine, open generator cutout switch and check for voltage. Turn engine and MASTER switch OFF, and close generator cutout switch. If voltage is present, repair/replace wire 2 of engine disconnect to engine generator relay lead (see WP 0211 00). If voltage is not present, go to step 7.

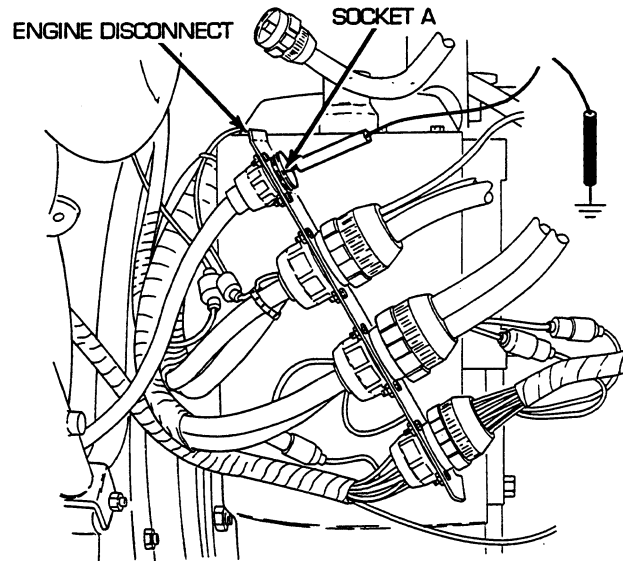

7. Reconnect generator power lead assembly to engine disconnect. Remove powerplant (see WP 0098 00). Disconnect wire 2 from generator, positive terminal B. Place red lead of multimeter on terminal of generator and black lead to ground. Turn MASTER switch on, start engine, open generator cutout switch and check for voltage. Turn engine and MASTER switch OFF, and close generator cutout switch. If voltage is present, repair/replace generator power lead assembly (see WP 0185 00). If voltage is not present, replace engine generator (see WP 0150 00).

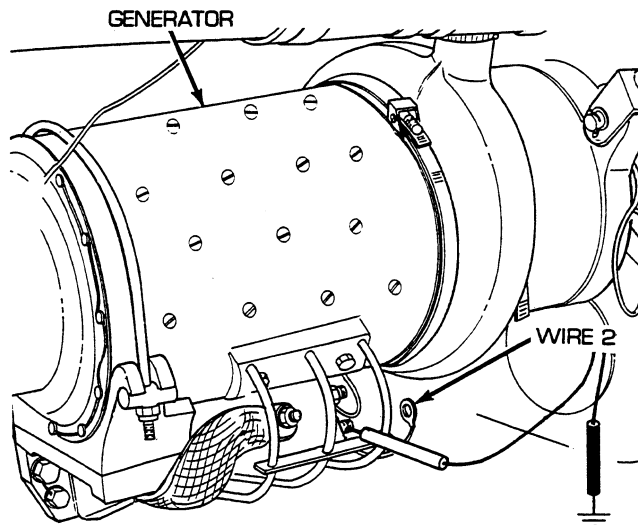

CORRECTIVE ACTION –Continued

8. Reconnect bulkhead to engine bracket and rear fuel tank transmitter wiring harness to switching relay box. Disconnect APU and engine generator relays to voltage regulator wiring harness from switching relay box. Place red lead of multimeter in socket D of wire 1-61 and black lead to ground. Turn MASTER switch on, start engine, open generator cutout switch and check for voltage. Turn engine and MASTER switch OFF and close generator cutout switch. If voltage is present, go to step 9. If voltage is not present, repair/replace wire 1-61 of APU and engine generator relays to voltage regulator wiring harness (see WP 0230 00).

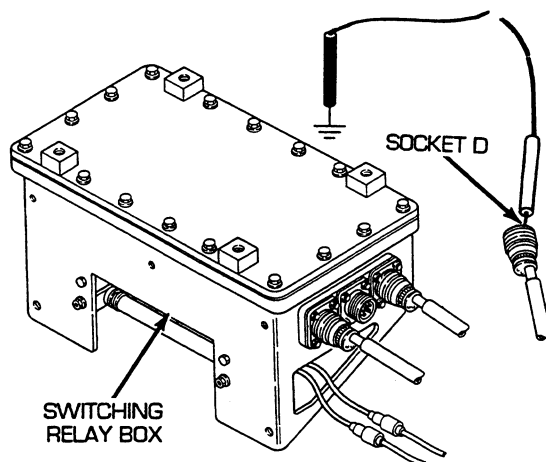

9. Reconnect APU and engine generator relays to voltage regulator wiring harness to engine regulator. Disconnect bulkhead to engine bracket and rear fuel tank transmitter wiring harness from switching relay box. Place red lead of multimeter on pin C of wire 1 and black lead to ground. Turn MASTER switch on, start engine, close generator cutout switch and check for voltage. Turn engine and MASTER switch OFF and open generator cutout switch. If voltage is present, go to step 10. If voltage is not present, replace switching relay box (see WP 0162 00).

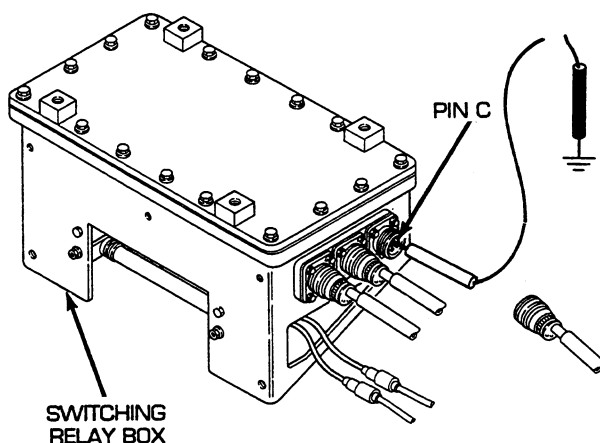

CORRECTIVE ACTION –Continued

10. Reconnect bulkhead to engine bracket and rear fuel tank transmitter to switching relay box. Disconnect bulkhead to engine wiring harness and starter relay wiring harness from bulkhead. Place red lead of multimeter in socket E of wire 1 and black lead to ground. Turn MASTER switch on, start engine, close generator cutout switch and check for voltage. If voltage is present, go to step 11. If voltage is not present, go to step 15.

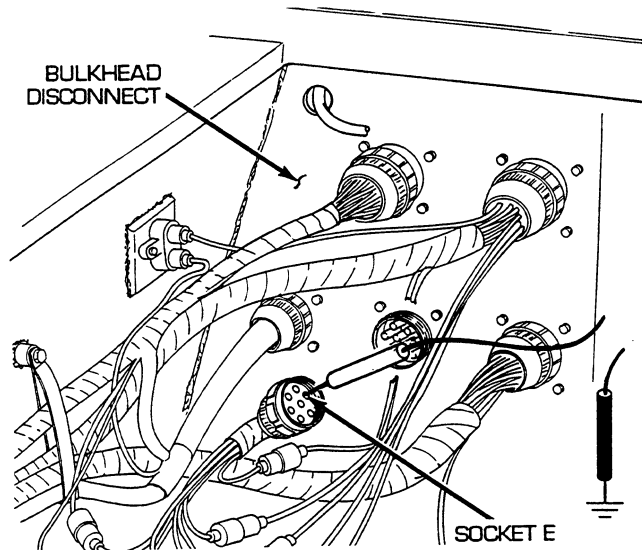

11. Reconnect bulkhead to engine bracket and rear fuel tank transmitter wiring harness to switching relay box. Disconnect electrical accessories panel wiring harness from electrical accessories panel. Place red lead of multimeter in socket C of wire 1 and black lead to ground. Turn MASTER switch on and check for voltage. Turn MASTER switch OFF. If voltage is present, go to step 12. If voltage is not present, repair/replace wire 1 of electrical accessories panel wiring harness.

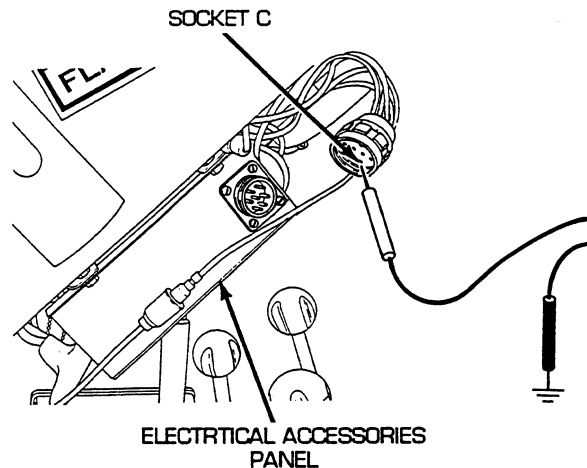

CORRECTIVE ACTION –Continued

12. Place red lead of multimeter in socket H of wire 1 and black lead to ground. Turn MASTER switch on, start engine, close generator cutout switch, and check for voltage. If voltage is present, go to step 13. If voltage is not present, go to step 18.

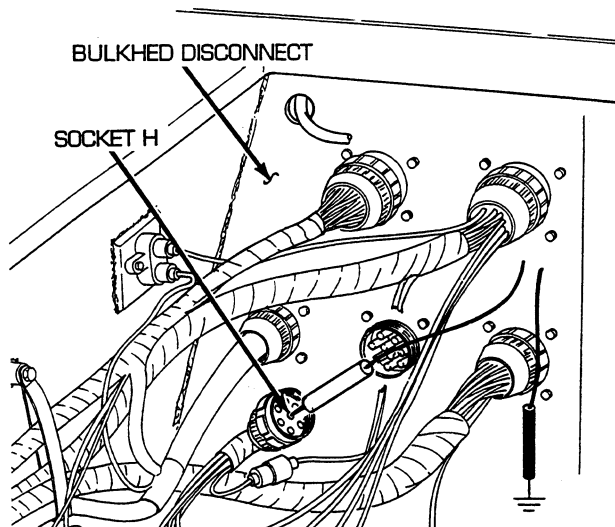

13. Reconnect bulkhead to engine wiring harness and starter relay wiring harness to bulkhead disconnect. Remove engine deck (see WP 0336 00). Disconnect engine wiring harness from engine disconnect. Place red lead of multimeter on socket C of wire 1 and black lead to ground. Turn MASTER switch on, start engine, open generator cutout switch and check for voltage. Turn engine and MASTER switch OFF and close generator cutout switch. If voltage is present, repair/replace engine wiring harness. If voltage is not present, go to step 14.

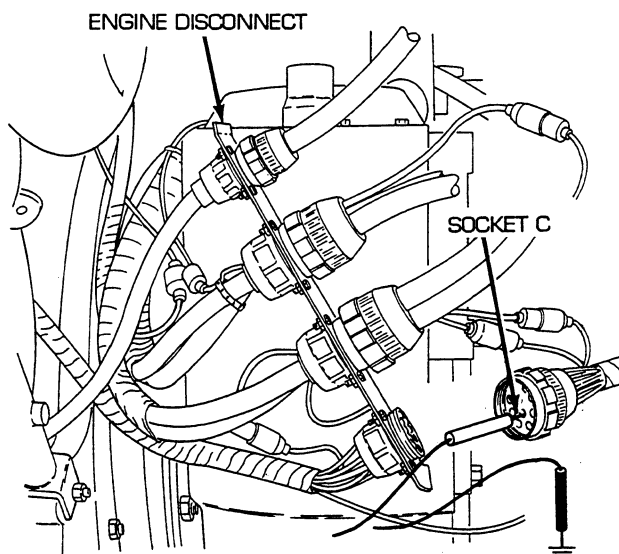

CORRECTIVE ACTION –Continued

14. Reconnect engine wiring harness to engine disconnect. Disconnect wire 1 of engine wiring harness from field terminal A of generator. Place red lead of multimeter on wire 1 and black lead to ground. Turn MASTER switch on, start engine, open generator cutout switch, and check for voltage. If voltage is present, replace generator assembly. If voltage is not present, repair/replace wire 1 of engine wiring harness.

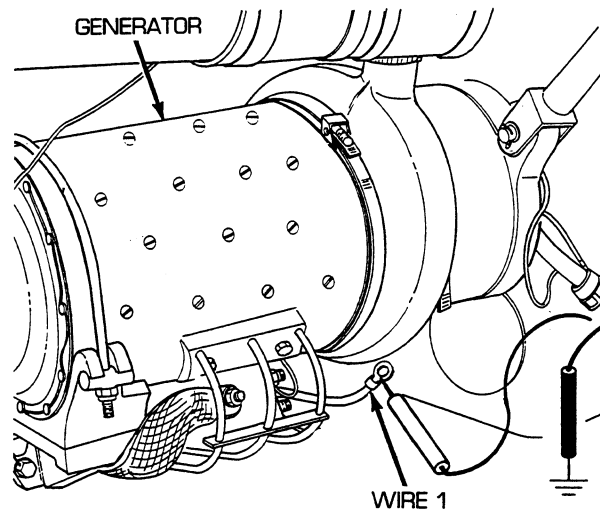

15. Reconnect electrical accessories panel wiring harness to electrical accessories panel. Disconnect bulkhead to engine harness and starter relay wiring harness from bulkhead disconnect. Place jumper wires from pin H to socket H and pin A to socket A. Place red lead of multimeter in socket E of wire 1 and black lead to ground. Turn MASTER switch on, start engine, open generator cutout switch and check for voltage. Turn engine and MASTER switch OFF and close generator cutout switch. If voltage is present, go to step 16. If voltage is not present, go to step 17.

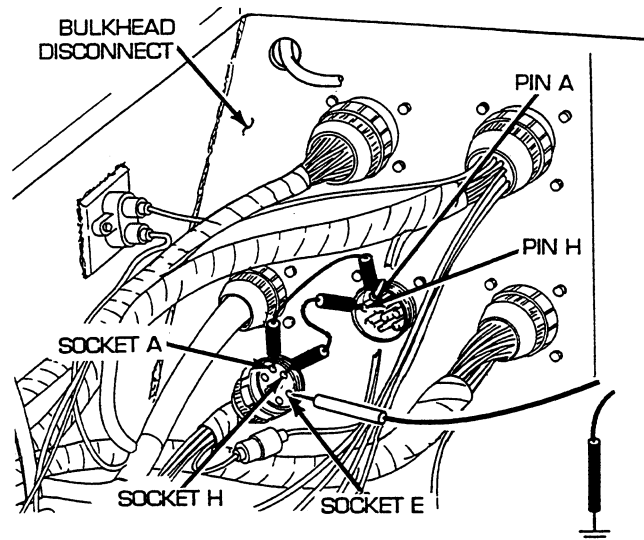

CORRECTIVE ACTION –Continued

16. Reconnect bulkhead to engine wiring harness and starter relay harness to bulkhead disconnect. Disconnect wire 1 (from socket C) of electrical accessories panel wiring harness from switch panel to neutral safety to bulkhead wiring harness. Place red lead of multimeter on male connector of wire 1 and black lead to ground. Turn MASTER switch on, start engine, and check for voltage. Turn engine and MASTER switch OFF. If voltage is present, repair/replace wire 1 of electrical accessories panel wiring harness (see WP 0196 00). If voltage is not present, repair/replace wire 1 of switch panel to neutral safety to bulkhead wiring harness (see WP 0203 00).

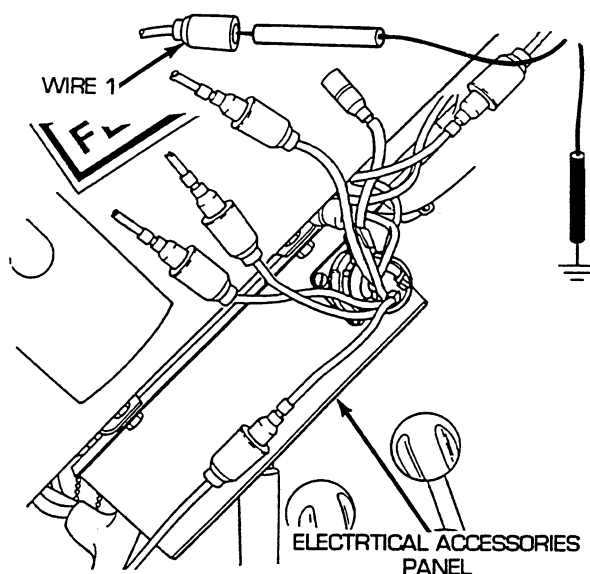

17. Reconnect bulkhead to engine wiring harness and starter relay wiring harness to bulkhead disconnect. Disconnect wire 1 of bulkhead to engine bracket and rear fuel tank transmitter wiring harness (from switching relay box) from bulkhead to engine wiring harness and starter relay wiring harness. Place red lead of multimeter on male connector of wire 1. Turn MASTER switch on, start engine, open generator cutout switch and check for voltage. Turn engine and MASTER switch OFF and close generator cutout switch. If voltage is present, repair/replace wire 1 of bulkhead to engine wiring harness and starter relay wiring harness (see WP 0221 00). If voltage is not present, repair/replace wire 1 of bulkhead to engine bracket and rear fuel tank transmitter wiring harness (see WP 0223 00).

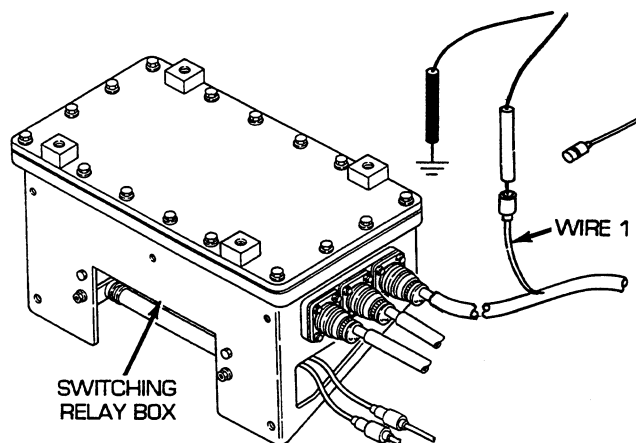

CORRECTIVE ACTION –Continued

18. Remove four screws (1) and four lockwashers (2), and release electrical accessories panel (3). Ground panel. Reconnect electrical accessories panel wiring harness to electrical accessories panel. Disconnect wire 1 (from socket D) from generator cutout switch. Place red lead of multimeter in wire 1 and black lead to ground. Turn MASTER switch on and check for voltage. Turn MASTER switch OFF. If voltage is present, go to step 19. If voltage is not present repair/replace wire 1 of bilge pump main power wiring harness from socket D (see WP 0233 00).

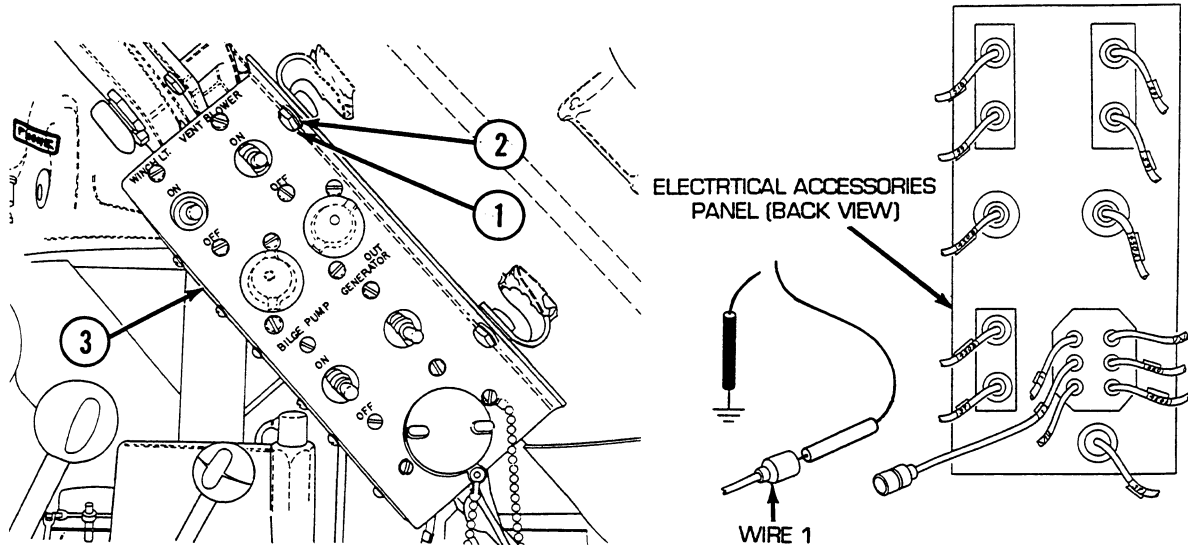

CORRECTIVE ACTION –Continued

19. Reconnect wire 1 (from socket D) to generator cutout switch. Disconnect wire 1 (from socket C) from generator cutout switch. Place red lead of multimeter on generator cutout switch and black lead to ground. Turn MASTER switch on, open generator cutout switch and check for voltage. Turn MASTER switch OFF, close generator cutout switch. If voltage is present, repair/replace wire 1 of bilge pump main power wiring harness (see WP 0233 00). If voltage is not present, replace generator cutout switch (see WP 0158 00).

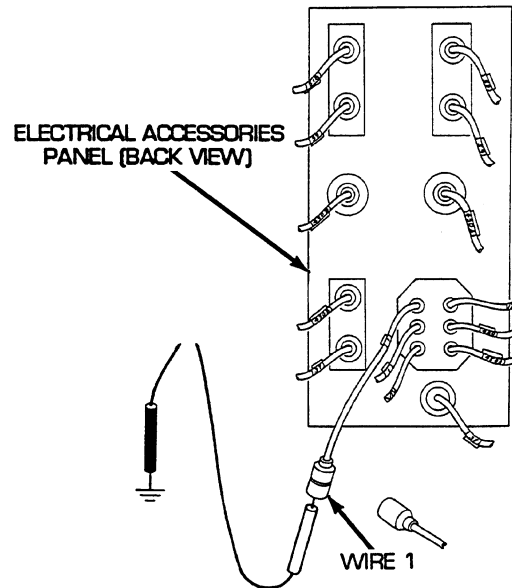
**END OF WORK PACKAGE**

UNIT MAINTENANCE
RECOVERY VEHICLE, FULL TRACKED: MEDIUM, M88A1
NSN 2350-00-122-6826, EIC AQA
APU GENERATOR SYSTEM (DUAL VOLTAGE) TROUBLESHOOTING PROCEDURE

INITIAL SETUP:**Tools and Special Tools**

Tool kit, general mechanic's (item 59, WP 0490 00)

References

WP 0154 00
WP 0203 00
WP 0221 00

References (cont.)

WP 0224 00
WP 0228 00
WP 0432 00
WP 0438 00
TM 9-2350-256-10

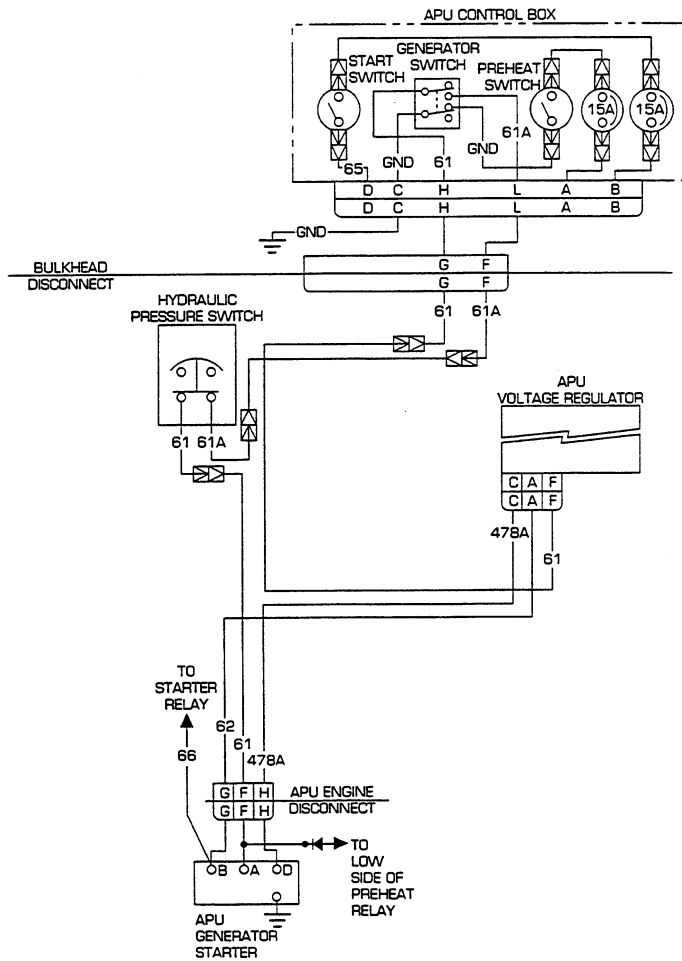
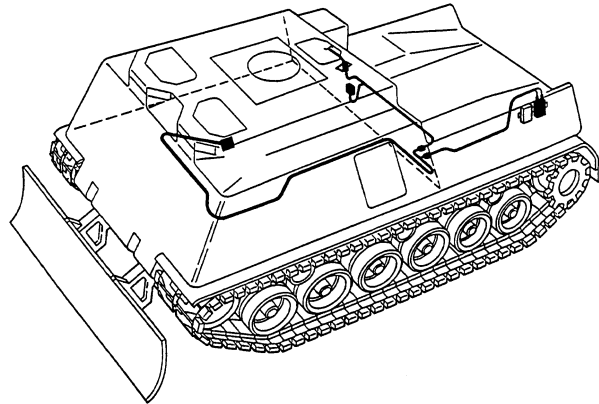

Troubleshooting Procedure

APU Generator System (Dual Voltage)

Symptom

APU generator system (dual voltage) malfunctioning.

Malfunction

Generator indicator reads in yellow or lower red region with APU engine running and APU generator switch on. Do steps 1 thru 19.

CORRECTIVE ACTION**WARNING**

Remove all jewelry such as rings, dog tags, bracelets, etc. If jewelry contacts a metal surface a direct short may result in instant heating of tools, damage to equipment, and injury or death to personnel.

1. Open air inlet doors (TM 9-2350-256-10). Disconnect batteries to master relay voltage regulator and slave receptacle wiring harness from APU regulator. Place red lead of multimeter on pin A of wire 62 and black lead to ground. Turn MASTER and APU GEN switches on and check for voltage. Turn MASTER and APU GEN switches OFF. If voltage is not present, troubleshoot battery circuit. If voltage is present, go to step 2.

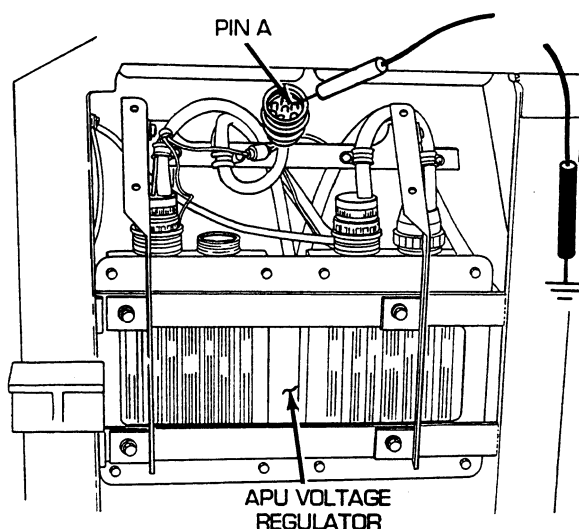

2. Place red lead of multimeter in socket A of wire 62 and black lead to ground. Turn MASTER and APU GEN switches ON, start APU, and check for voltage. Turn MASTER and APU GEN switches OFF. If voltage is present, go to step 3. If voltage is not present, replace APU voltage regulator (see WP 0154 00).

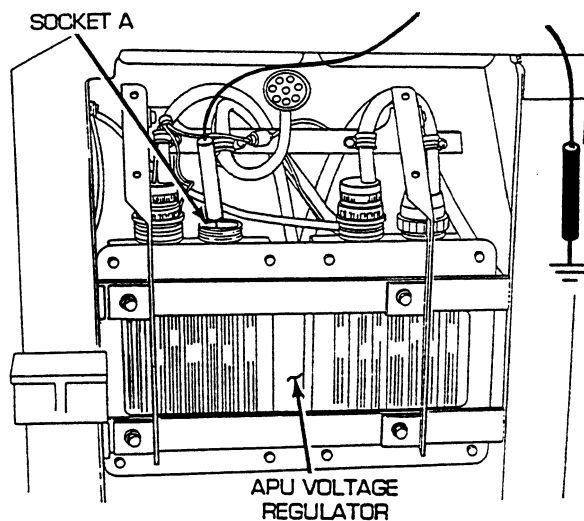

CORRECTIVE ACTION –Continued

3. Reconnect batteries to master relay, voltage regulator, and slave receptacle wiring harness to APU regulator. Disconnect bulkhead to APU to master relay and rigger’s lights wiring harness from APU regulator. Place red lead of multimeter in socket F of wire 61 and black lead to ground. Turn MASTER and APU GEN switches ON, start APU, and check for voltage. Turn APU and MASTER and APU GEN switches OFF. If voltage is present, go to step 4. If voltage is not present, replace APU voltage regulator (see WP 0154 00).

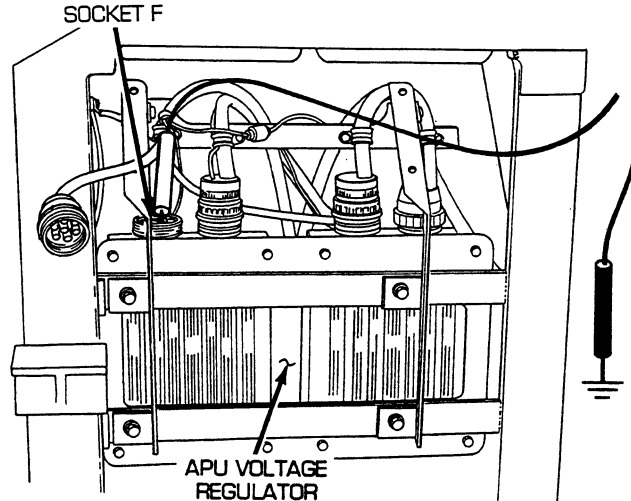

4. Place red lead of multimeter on pin C of wire 478A and black lead to ground. Turn MASTER and APU GEN switches ON, start APU, and check for voltage. Turn MASTER and APU GEN switches OFF. If voltage is not present, replace APU regulator (see WP 0154 00). If voltage is present, go to step 5.

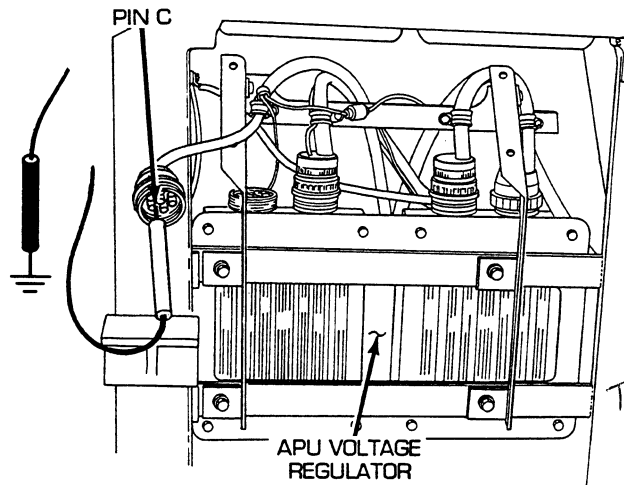

CORRECTIVE ACTION –Continued

5. Reconnect bulkhead to APU, master relay, and rigger's lights wiring harness to APU regulator. Open center-front air inlet doors (TM 9-2350-256-10). Disconnect bulkhead to APU, master relay, and rigger's lights wiring harness from APU engine disconnect. Place red lead of multimeter on pin H of wire 478A. Turn MASTER and APU GEN switches ON and check for voltage. Turn MASTER and APU GEN switches OFF. If voltage is not present, repair/replace wire 478A of bulkhead to APU, master relay, and rigger's lights wiring harness (see WP 0224 00). If voltage is present, go to step 6.

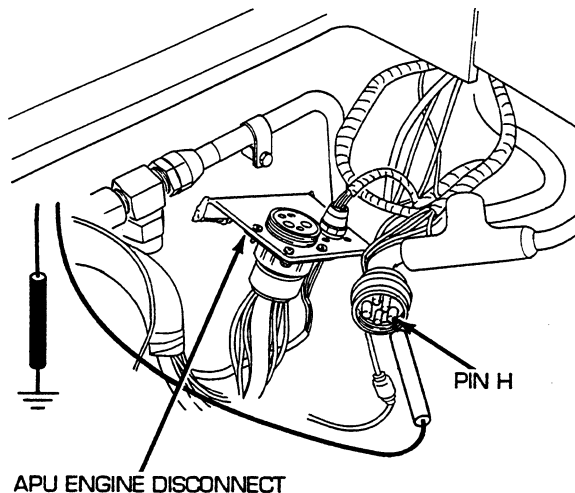

6. Reconnect bulkhead to APU, master relay, and rigger's lights wiring harness to APU regulator. Disconnect bulkhead to APU, master relay, and rigger's lights wiring harness from APU engine disconnect. Place red lead of multimeter in socket G of wire 62 and black lead to ground. Turn MASTER and APU GEN switches ON and check for voltage. Turn MASTER and APU GEN switches OFF. If voltage is present, go to step 7. If voltage is not present, repair/replace wire 62 of bulkhead to APU, master relay, and rigger's lights wiring harness (see WP 0224 00).

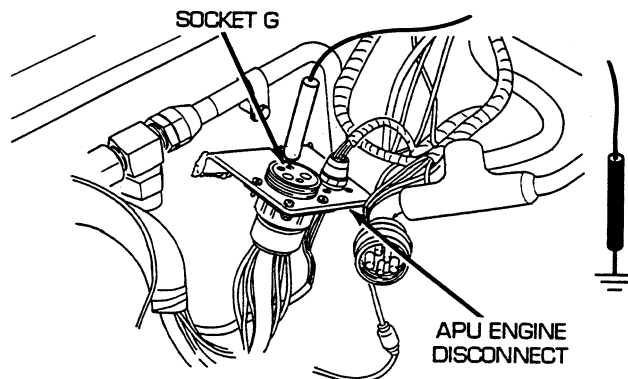

CORRECTIVE ACTION –Continued

7. Reconnect bulkhead to APU to master relay and rigger’s lights wiring harness to APU regulator. Disconnect APU control box to foot dimmer switch and bulkhead wiring harness from APU control box. Place red lead of multimeter in socket H of wire 61 and black lead to ground. Turn MASTER and APU GEN switches ON and check for voltage. Turn MASTER and APU GEN switches OFF. If voltage is present, go to step 8. If voltage is not present, go to step 13.

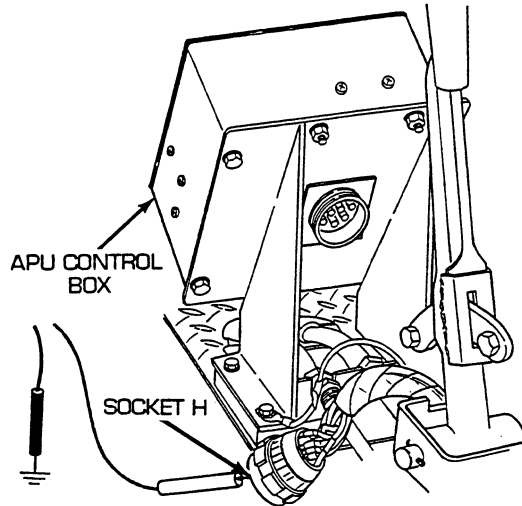

8. Remove four nuts (1), four lockwashers (2), four screws (3), and release APU control box (4) from mounting brackets. Place a jumper from pin H to socket H. Place red lead of multimeter on pin L of wire 61A and black lead to ground. Turn MASTER and APU GEN switches on and check for voltage. Turn MASTER and APU GEN switches OFF. If voltage is present, go to step 11. If voltage is not present, go to step 9.

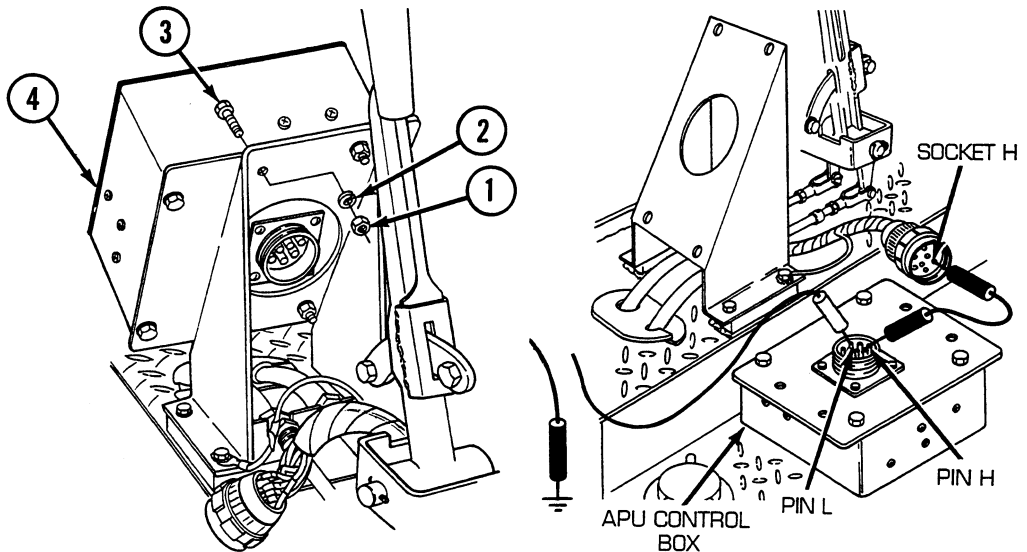

CORRECTIVE ACTION –Continued

9. Reconnect APU control box to foot dimmer switch and bulkhead wiring harness to APU control box. Remove four screws (5) and four lockwashers (6), and release rear panel (7) from APU control box (4). Disconnect wire 61 of APU control box wiring harness from APU GEN switch. Place red lead of multimeter in wire 61 and black lead to ground. Turn MASTER and APU GEN switch ON and check for voltage. If voltage is present, go to step 10. If voltage is not present, repair/replace APU control box wiring harness (see WP 0438 00).

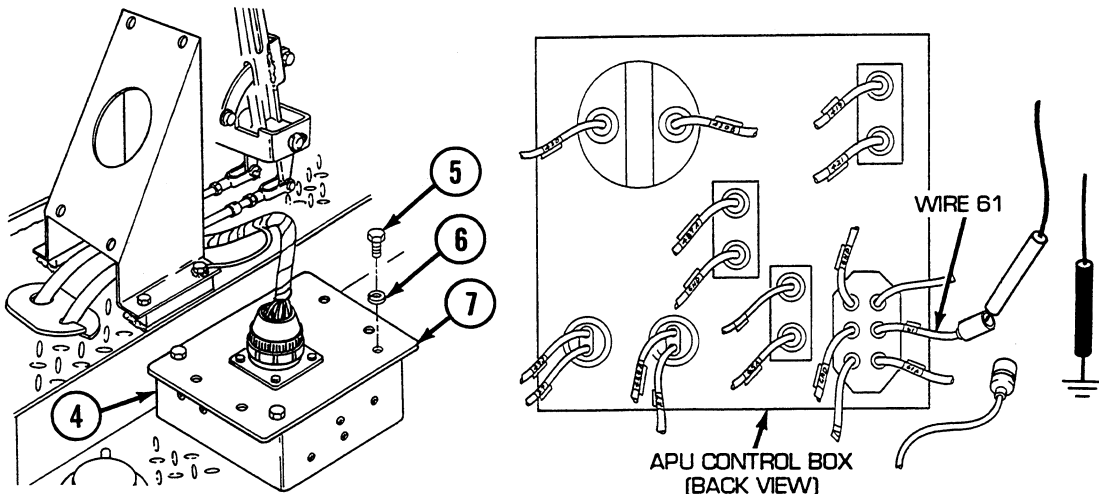

10. Reconnect wire 61 to APU GEN switch. Disconnect wire 61A from APU GEN switch. Place red lead of multimeter on APU GEN switch terminal and black lead to ground. Turn MASTER and APU GEN switches ON, and check for voltage. Turn MASTER and APU GEN switches OFF. If voltage is present, repair/replace wire 61A of APU control box wiring harness (see WP 0438 00). If voltage is not present, replace APU GEN switch (see WP 0438 00).

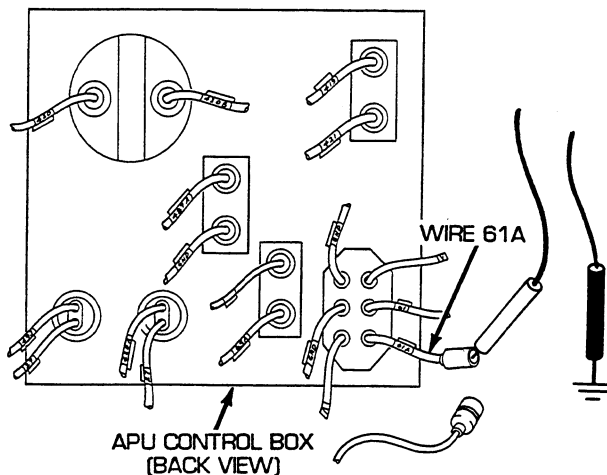

CORRECTIVE ACTION –Continued

11. Reconnect wire 61A to APU GEN switch. Install APU control box (4), four screws (3), four lock-washers (2), and four nuts (1) to mounting bracket. Install APU control box to foot dimmer switch and bulkhead wiring harness to APU control box. Open air inlet doors. Disconnect bulkhead to engine wiring harness and starter relay wiring harness from bulkhead disconnect. Place red lead of multimeter on pin F of wire 61A and black lead to ground. Turn MASTER and APU GEN switches ON and check for voltage. Turn MASTER and APU GEN switches OFF. If voltage is present, go to step 16. If voltage is not present, go to step 12.

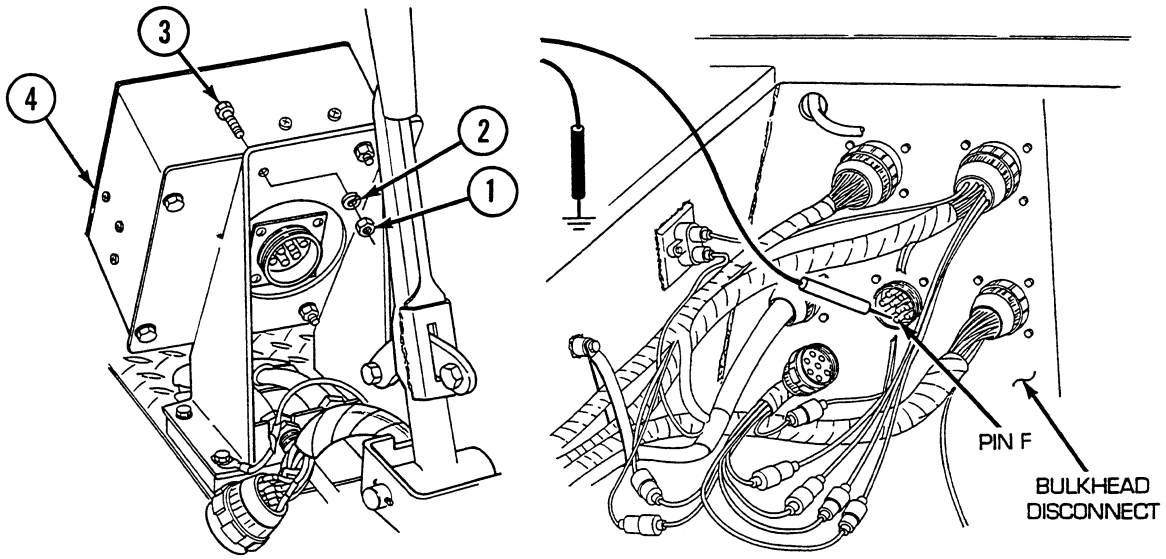

12. Reconnect bulkhead to engine wiring harness and starter relay wiring harness to bulkhead. Disconnect wire 61A of switch panel to neutral safety switch to bulkhead wiring harness from APU control box to foot dimmer switch and bulkhead wiring harness. Place red lead of multimeter in female connector wire 61A and black lead to ground. Turn MASTER and APU GEN switches ON and check for voltage. Turn MASTER and APU GEN switches OFF. If voltage is present, replace wire 61A of switch panel to neutral safety to bulkhead wiring harness (see WP 0203 00). If voltage is not present, repair/replace wire 61A of APU control box to foot dimmer switch and bulkhead wiring harness (see WP 0228 00).

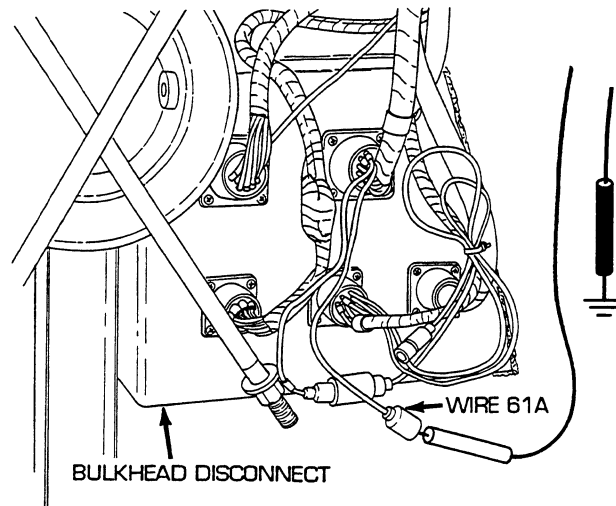

CORRECTIVE ACTION –Continued

13. Reconnect APU control box to foot dimmer switch and bulkhead wiring harness to APU control box. Disconnect bulkhead to engine harness and starter relay wiring harness from bulkhead disconnect. Place red lead of multimeter in socket G of wire 61 and black lead to ground. Turn MASTER and APU GEN switches ON and check for voltage. Turn MASTER and APU GEN switches OFF. If voltage is present, go to step 14. If voltage is not present, go step 15.

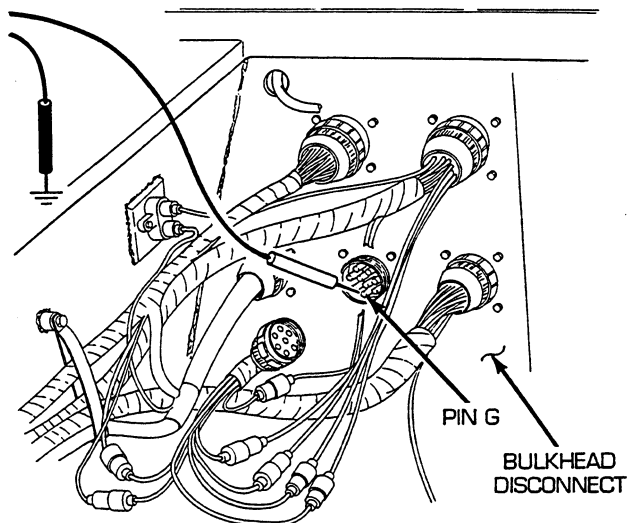

14. Reconnect bulkhead to engine wiring harness and starter relay wiring harness to bulkhead. Disconnect wire 61 of switch panel to neutral safety to bulkhead wiring harness from APU control box to foot dimmer switch and bulkhead wiring harness. Place red lead of multimeter in female connector of wire 61 and black lead to ground. Turn MASTER and APU GEN switches ON and check for voltage. Turn MASTER and APU GEN switches OFF. If voltage is present, repair/replace wire 61 of APU control box to foot dimmer switch and bulkhead wiring harness (see WP 0228 00). If voltage is not present, repair/replace wire 61 of switch panel to neutral safety to bulkhead wiring harness (see WP 0203 00).

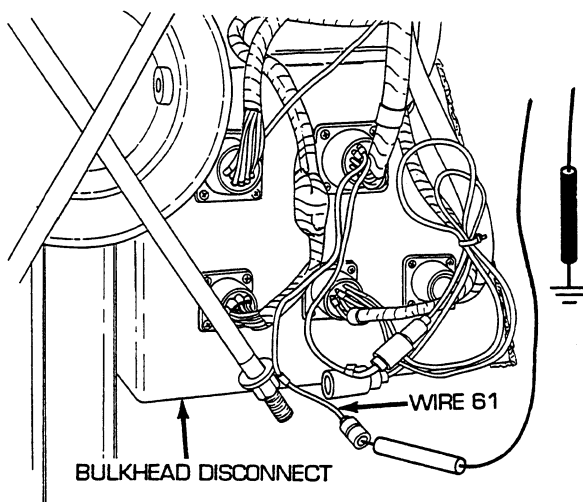

CORRECTIVE ACTION –Continued

15. Reconnect bulkhead to engine wiring harness and starter relay wiring harness to bulkhead disconnect. Disconnect wire 61 of bulkhead to engine wiring harness and starter relay wiring harness from wire 61 of bulkhead to APU, master relay, and rigger's lights wiring harness. Place red lead of multimeter on male connector wire 61 and black lead to ground. Turn MASTER and APU GEN switches ON and check for voltage. Turn MASTER and APU GEN switches OFF. If voltage is present, repair/replace wire 61 of bulkhead to engine wiring harness and starter relay wiring harness to bulkhead disconnect (see WP 0221 00). If voltage is not present, repair/replace wire 61 of bulkhead to APU, master relay, and rigger's lights wiring harness (see WP 0224 00).

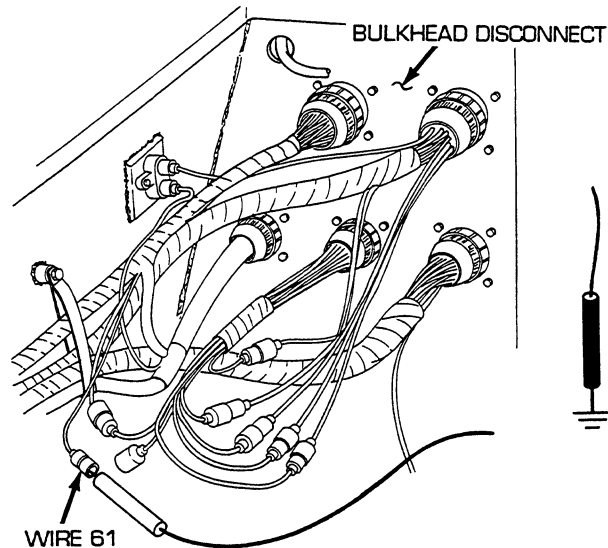

16. Reconnect bulkhead to engine wiring harness and starter relay wiring harness to bulkhead disconnect. Disconnect wire 61A from hydraulic pressure switch. Place red lead of multimeter in wire 61A and black lead to ground. Turn MASTER, APU pressure and APU GEN switches ON and check for voltage. Turn MASTER and APU GEN switches OFF. If voltage is present, go to step 18. If voltage is not present, go to step 17.

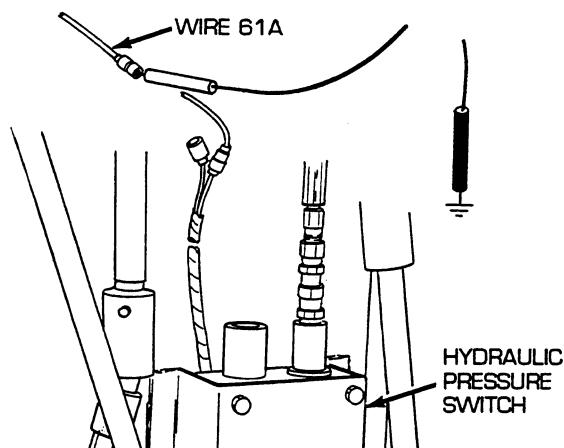

CORRECTIVE ACTION –Continued

17. Reconnect wire 61A to hydraulic pressure switch. Disconnect wire 61A of bulkhead to engine wiring harness and starter relay wiring harness from bulkhead to APU, master relay, and rigger's lights wiring harness. Place red lead of multimeter on male connector of wire 61A and black lead to ground. Turn MASTER and APU GEN switches ON and check for voltage. Turn MASTER and APU GEN switches OFF. If voltage is present, repair/replace wire 61A of bulkhead to APU, master relay, and rigger's lights wiring harness (see WP 0224 00). If voltage is not present, notify Direct Support Maintenance.

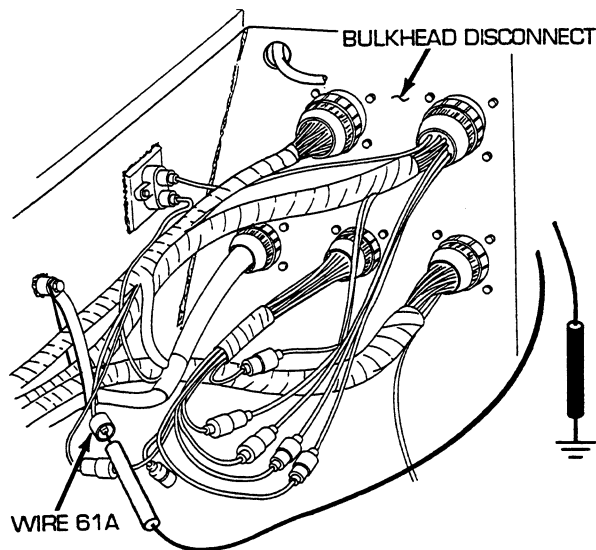

18. Reconnect wire 61A to hydraulic pressure switch. Disconnect wire 61 from hydraulic pressure switch. Place red lead of multimeter on wire 61 and black lead to ground. Turn MASTER and APU GEN switches ON and check for voltage. If voltage is present, go to step 19. If voltage is not present, replace hydraulic pressure switch (see WP 0432 00).

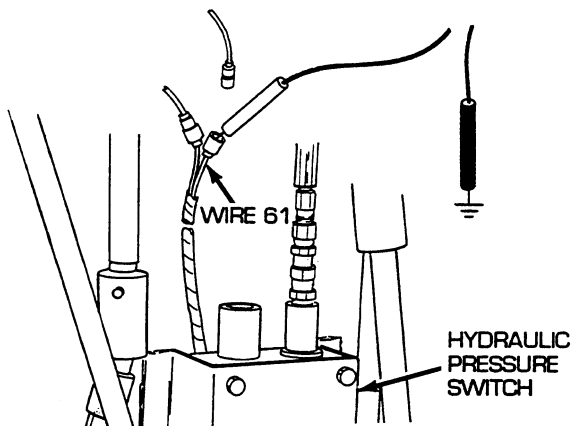

CORRECTIVE ACTION –Continued

19. Disconnect bulkhead to APU, master relay, and rigger's lights wiring harness from APU engine disconnect. Place red lead of multimeter in socket F of wire 61 and black lead to ground. Turn MASTER, APU pressure and APU GEN switches ON and check for voltage. Turn MASTER, APU pressure and APU GEN switches OFF. If voltage is present, notify Direct Support Maintenance. If voltage is not present, repair/replace wire 61 of bulkhead to APU, master relay, and rigger's lights wiring harness (see WP 0224 00).

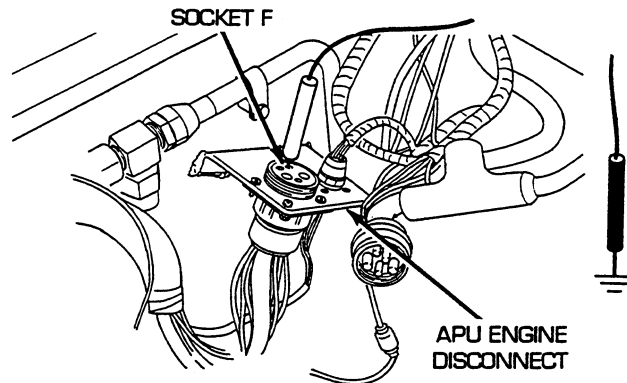
**END OF WORK PACKAGE**

UNIT MAINTENANCE
RECOVERY VEHICLE, FULL TRACKED: MEDIUM, M88A1
NSN 2350-00-122-6826, EIC AQA
APU GENERATOR SYSTEM (SINGLE VOLTAGE) TROUBLESHOOTING PROCEDURE

INITIAL SETUP:**Tools and Special Tools**

Tool kit, general mechanic's (item 59, WP 0490 00)

References

WP 0154 00
WP 0162 00
WP 0203 00
WP 0221 00

References (cont.)

WP 0225 00
WP 0229 00
WP 0230 00
WP 0432 00
WP 0438 00
TM 9-2350-256-10

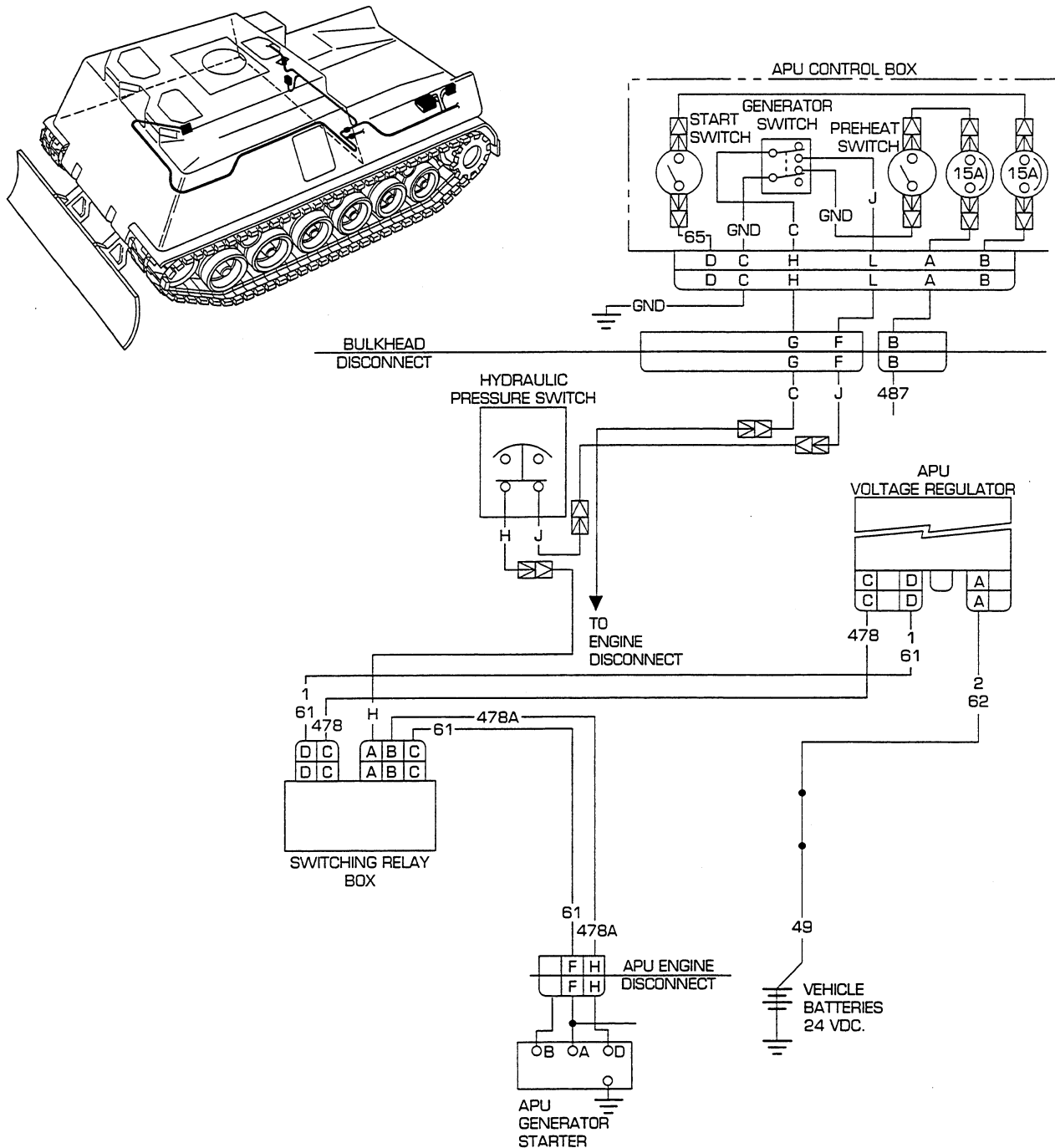

Troubleshooting Procedure

APU Generator System (Single Voltage)

Symptom

APU generator system (single voltage) malfunctioning.

Malfunction

Generator indicator reads in yellow or lower red region with APU engine running and APU generator switch on. Do steps 1 thru 23.

CORRECTIVE ACTION**WARNING**

Remove all jewelry such as rings, dog tags, bracelets, etc. If jewelry contacts a metal surface a direct short may result in instant heating of tools, damage to equipment, and injury or death to personnel.

1. Open air inlet doors (TM 9-2350-256-10). Disconnect batteries to master relay, voltage regulator, and slave receptacle wiring harness from regulator. Place red lead of multimeter on socket A of wire 62/2 and black lead to ground. Turn MASTER and APU GEN switches on and check for voltage. Turn MASTER and APU GEN switches OFF. If voltage is not present, troubleshoot battery circuit. If voltage is present, go to step 2.

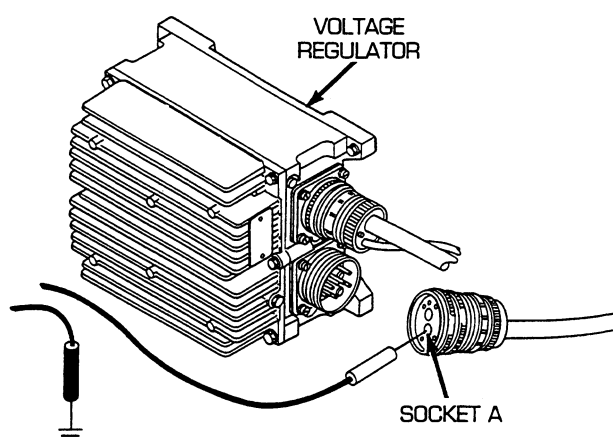

2. Place red lead of multimeter in pin A of wire 62/2 and black lead to ground. Turn MASTER and APU GEN switches ON, start APU, and check for voltage. Turn APU and MASTER and APU GEN switches OFF. If voltage is present, go to step 3. If voltage is not present, replace voltage regulator (see WP 0154 00).

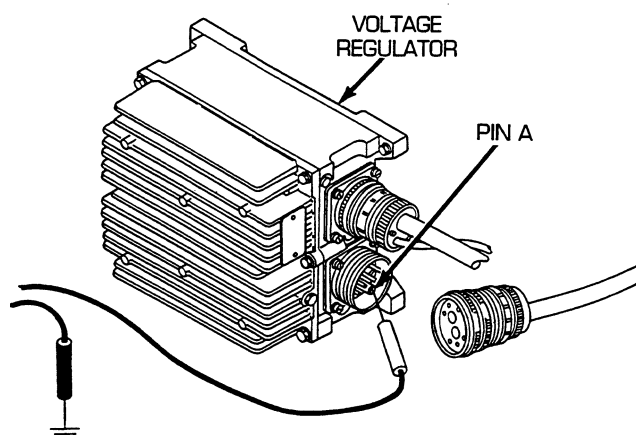

CORRECTIVE ACTION –Continued

3. Reconnect batteries to master relay, voltage regulator, and slave receptacle wiring harness to regulator. Disconnect bulkhead to APU, master relay, and rigger's lights wiring harness from regulator. Place red lead of multimeter in socket D of wire 61/1 and black lead to ground. Turn MASTER and APU GEN switches ON, start APU, and check for voltage. Turn APU and MASTER and APU GEN switches OFF. If voltage is present, go to step 4. If voltage is not present, replace voltage regulator (see WP 0154 00).

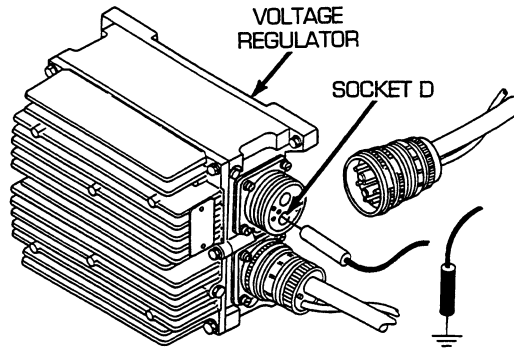

4. Place red lead of multimeter on pin C of wire 478 and black lead to ground. Turn MASTER and APU GEN switches ON, start APU, and check for voltage. Turn APU and MASTER and APU GEN switches OFF. If voltage is not present, replace regulator (see WP 0154 00). If voltage is present, go to step 5.

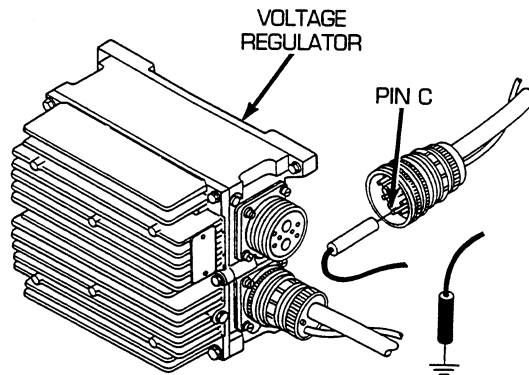

CORRECTIVE ACTION –Continued

5. Reconnect bulkhead to APU, master relay, and rigger's lights wiring harness to regulator. Disconnect engine generator relays to voltage regulator wiring harness at switching relay box. Place red lead of multimeter in socket C of wire 478. Turn MASTER and APU GEN switches ON, start APU, and check for voltage. Turn APU and MASTER and APU GEN switches OFF. If voltage is not present, repair/replace wire 478 of engine generator relays to voltage regulator wiring harness (see WP 0230 00). If voltage is present, go to step 6.

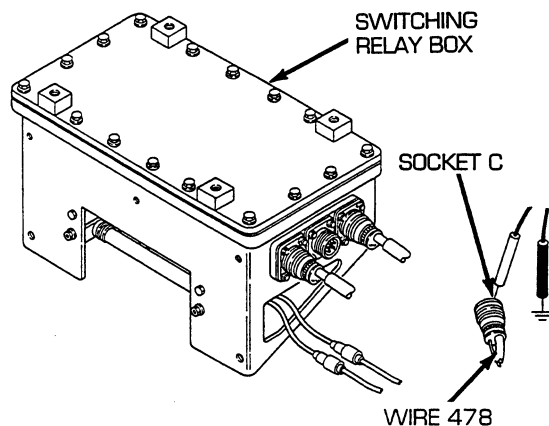

6. Place red lead of multimeter in socket D of wire 61/1. Turn MASTER and APU GEN switches ON, start APU, and check for voltage. Turn APU and MASTER and APU GEN switches OFF. If voltage is not present, repair/replace wire 61/1 of engine generator relays to voltage regulator wiring harness (see WP 0230 00). If voltage is present, go to step 7.

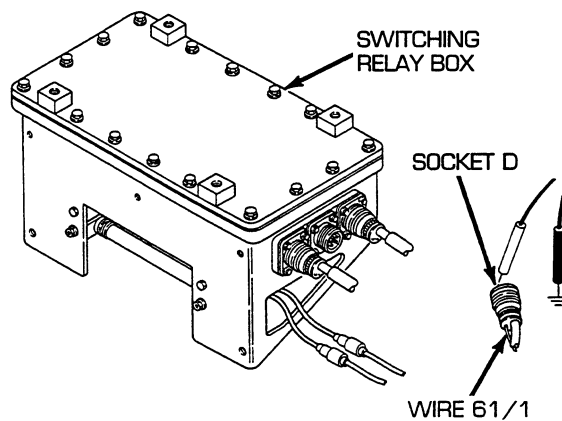

CORRECTIVE ACTION –Continued

7. Reconnect engine generator relays to voltage regulator wiring harness to switching box relay. Disconnect bulkhead to APU, master relay, and rigger’s lights wiring harness at switching box relay. Place red lead of multimeter in socket C of wire 61. Turn MASTER and APU GEN switches ON, start APU, and check for voltage. Turn APU and MASTER and APU GEN switches OFF. If voltage is not present, replace switching relay box (see WP 0162 00). If voltage is present, go to step 8.

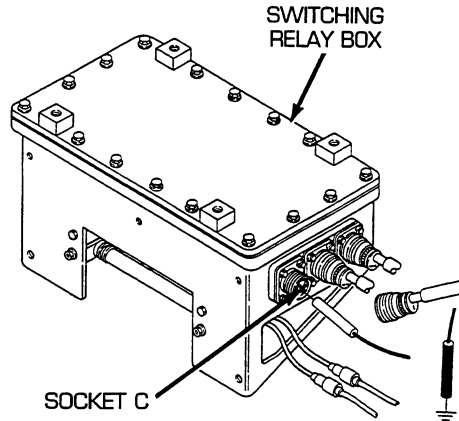

8. Place red lead on pin B of wire 478A. Turn MASTER and APU GEN switches ON, start APU, and check for voltage. Turn APU and MASTER and APU GEN switches OFF. If voltage is not present, replace switching relay box (see WP 0162 00). If voltage is present, go to step 9.

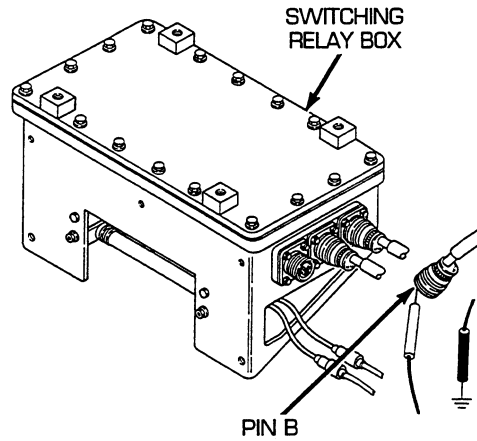

CORRECTIVE ACTION –Continued

9. Reconnect bulkhead to APU, master relay, and rigger's lights wiring harness to switching box relay. Open front grille doors (TM 9-2350-256-10). Disconnect bulkhead to APU, master relay, and rigger's lights wiring harness from APU engine disconnect. Place red lead of multimeter on pin H of wire 478A. Turn MASTER and APU GEN switches ON and check for voltage. Turn MASTER and APU GEN switches OFF. If voltage is not present, repair/replace wire 478A of bulkhead to APU, master relay, and rigger's lights wiring harness (see WP 0225 00). If voltage is present, go to step 10.

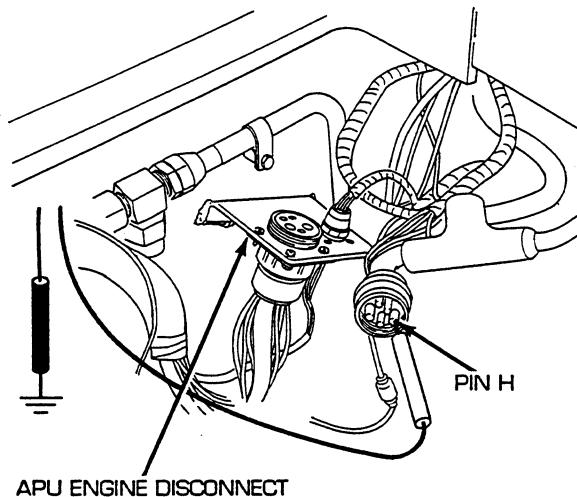

10. Place red lead of multimeter in socket G of wire 62 and black lead to ground. Turn MASTER and APU GEN switches ON and check for voltage. Turn MASTER and APU GEN switches OFF. If voltage is present, go to step 11. If voltage is not present, repair/replace wire 62 of bulkhead to APU, master relay, and rigger's lights wiring harness (see WP 0225 00).

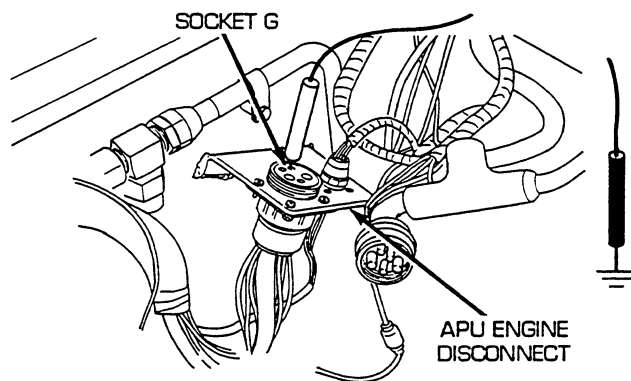

CORRECTIVE ACTION –Continued

11. Reconnect bulkhead to APU, master relay, and rigger’s lights wiring harness to APU engine disconnect. Disconnect APU control box to foot dimmer switch and bulkhead wiring harness from APU control box. Place red lead of multimeter in socket H of wire C and black lead to ground. Turn MASTER and APU GEN switches ON and check for voltage. Turn MASTER and APU GEN switches OFF. If voltage is present, go to step 12. If voltage is not present, go to step 17.

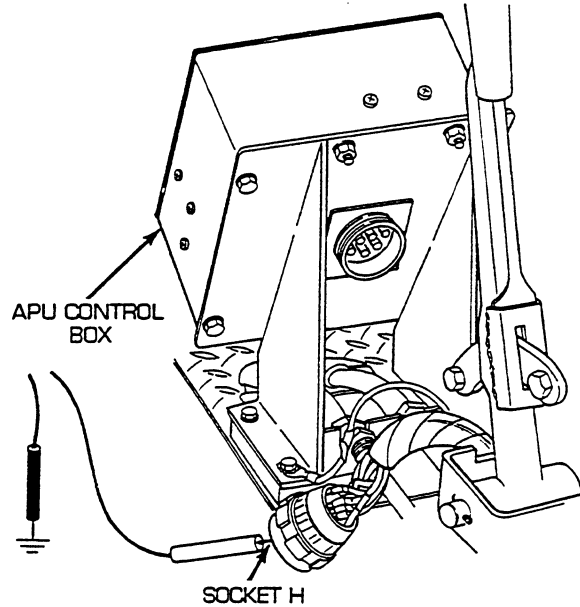

12. Remove four nuts (1), four lockwashers (2), four screws (3), and APU control box (4) from mounting brackets. Place a jumper from pin H to socket H. Place red lead of multimeter on pin L of wire J and black lead to ground. Turn MASTER and APU GEN switches on and check for voltage. Turn MASTER and APU GEN switches OFF. If voltage is present, go to step 15. If voltage is not present, go to step 16.

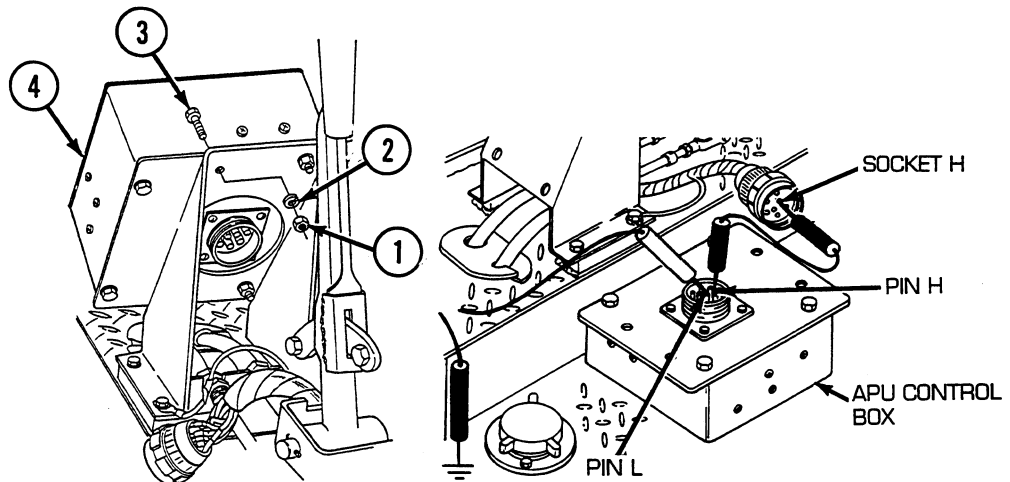

CORRECTIVE ACTION –Continued

13. Reconnect APU control box to foot dimmer switch and bulkhead wiring harness to APU control box. Remove four screws (5), four lockwashers (6), and rear panel (7) from APU control box (4). Disconnect wire C of APU control box wiring harness from APU GEN switch. Place red lead of multimeter in wire C and black lead to ground. Turn MASTER and APU GEN switches on and check for voltage. If voltage is present, go to step 14. If voltage is not present, repair/replace wire C of APU control box wiring harness (see WP 0438 00).

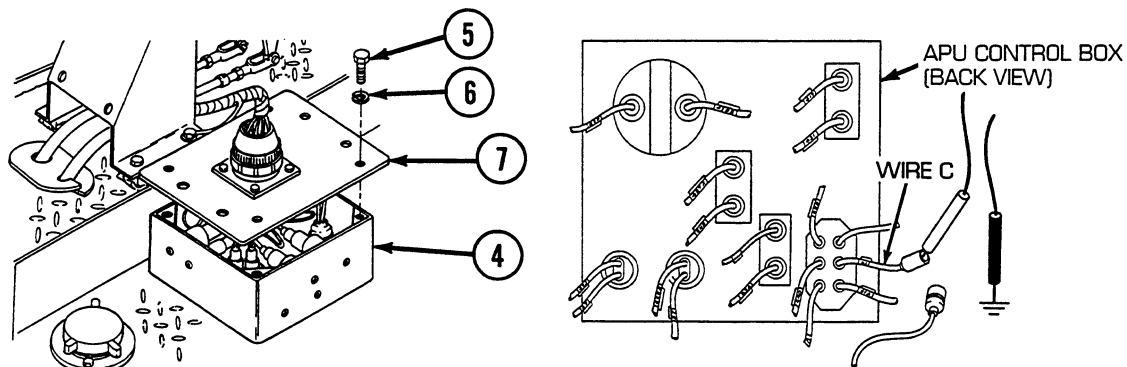

14. Reconnect wire C to APU GEN switch. Disconnect wire J from APU GEN switch. Place red lead of multimeter on APU GEN switch terminal and black lead to ground. Turn MASTER and APU GEN switches ON, and check for voltage. Turn MASTER and APU GEN switches OFF. If voltage is present, repair/replace wire J of APU control box wiring harness (see WP 0438 00). If voltage is not present, replace APU GEN switch (see WP 0438 00). Reconnect wire J to APU GEN switch. Install rear panel (7), four lockwashers (6), and four screws (5) to APU control box (4). Disconnect APU control box to foot dimmer switch and bulkhead wiring harness at APU control box.

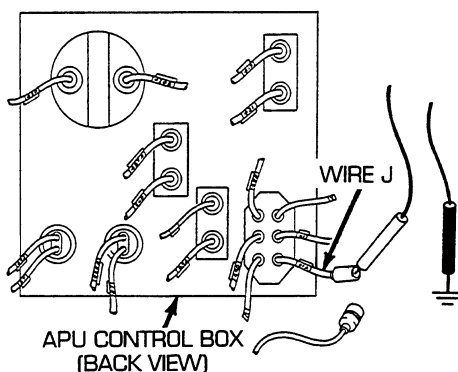

CORRECTIVE ACTION –Continued

15. Install APU control box (4), four screws (3), four lockwashers (2), and four nuts (1). Reconnect APU control box to foot dimmer switch and bulkhead wiring harness to APU control box. Disconnect bulkhead to engine wiring harness and starter relay wiring harness from bulkhead disconnect. Place red lead of multimeter on pin F of wire J and black lead to ground. Turn MASTER and APU GEN switches ON and check for voltage. Turn MASTER and APU GEN switches OFF. If voltage is present, go to step 21. If voltage is not present, go to step 16.

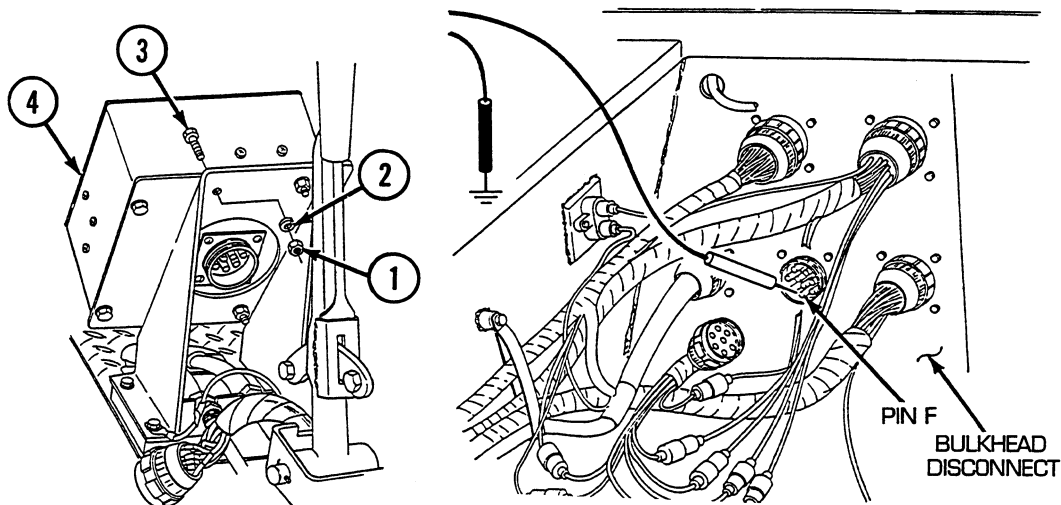

16. Reconnect bulkhead to engine wiring harness and starter relay wiring harness to bulkhead. Disconnect wire J of switch panel to neutral safety switch to bulkhead wiring harness from APU control box to foot dimmer switch and bulkhead wiring harness. Place red lead of multimeter in female connector wire J and black lead to ground. Turn MASTER and APU GEN switches ON and check for voltage. Turn MASTER and APU GEN switches OFF. If voltage is present, replace wire J of switch panel to neutral safety to bulkhead wiring harness (see WP 0203 00). If voltage is not present, repair/replace wire J of APU control box to foot dimmer switch and bulkhead wiring harness (see WP 0229 00).

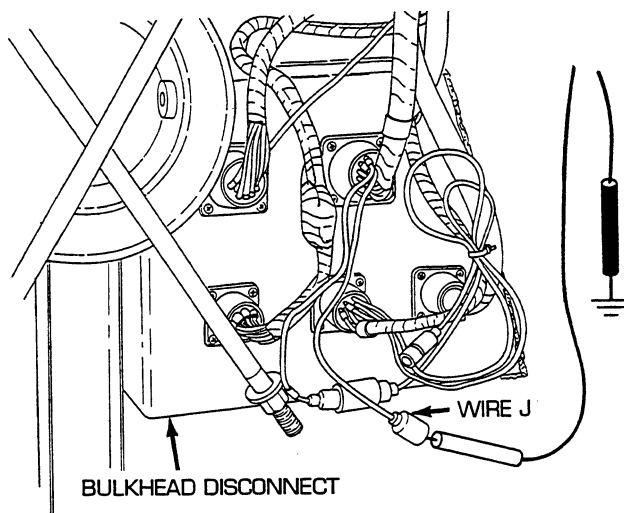

CORRECTIVE ACTION –Continued

17. Reconnect APU control box to foot dimmer switch and bulkhead wiring harness to APU control box. Disconnect bulkhead to engine harness and starter relay wiring harness from bulkhead disconnect. Place red lead of multimeter in socket G of wire C and black lead to ground. Turn MASTER and APU GEN switches ON and check for voltage. Turn MASTER and APU GEN switches OFF. If voltage is present, go to step 18. If voltage is not present, go step 19.

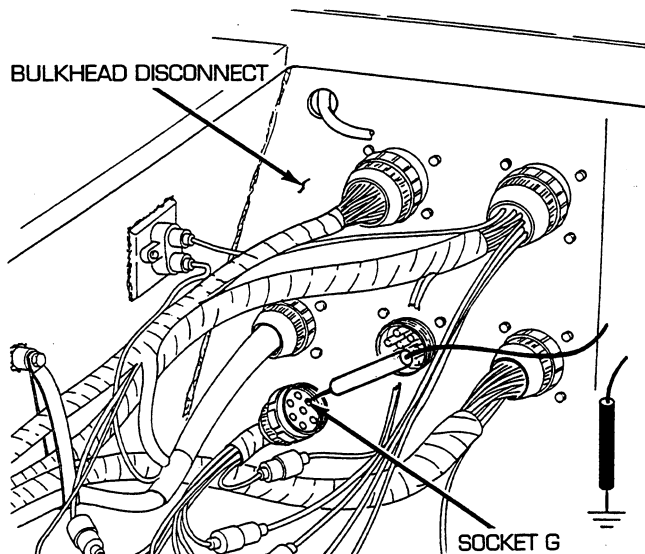

18. Reconnect bulkhead to engine wiring harness and starter relay wiring harness to bulkhead. Disconnect wire C of switch panel to neutral safety to bulkhead wiring harness from APU control box to foot dimmer switch and bulkhead wiring harness. Place red lead of multimeter in female connector of wire C and black lead to ground. Turn MASTER and APU GEN switches ON and check for voltage. Turn MASTER and APU GEN switches OFF. If voltage is present, repair/replace wire C of APU control box to foot dimmer switch and bulkhead wiring harness (see WP 0229 00). If voltage is not present, repair/replace wire C of switch panel to neutral safety to bulkhead wiring harness (see WP 0203 00).

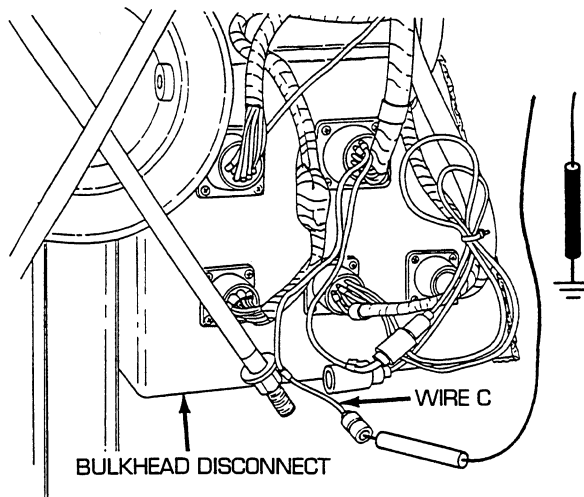

CORRECTIVE ACTION –Continued

19. Reconnect bulkhead to engine wiring harness and starter relay wiring harness to bulkhead disconnect. Disconnect wire C of bulkhead to engine wiring harness and starter relay wiring harness from wire C of bulkhead to APU, master relay, and rigger's lights wiring harness. Place red lead of multimeter on male connector wire C and black lead to ground. Turn MASTER and APU GEN switches ON and check for voltage. Turn MASTER and APU GEN switches OFF. If voltage is present, repair/replace wire C of bulkhead to engine wiring harness and starter relay wiring harness to bulkhead disconnect (see WP 0221 00). If voltage is not present, repair/replace wire C of bulkhead to APU, master relay, and rigger's lights wiring harness (see WP 0225 00).

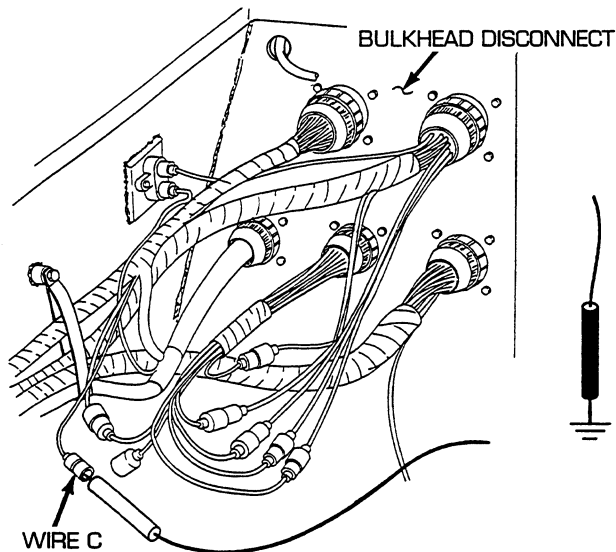

20. Reconnect bulkhead to engine wiring harness and starter relay wiring harness to bulkhead disconnect. Disconnect wire J from hydraulic pressure switch. Place red lead of multimeter in wire J and black lead to ground. Turn MASTER, APU pressure and APU GEN switches ON and check for voltage. Turn MASTER and APU GEN switches OFF. If voltage is present, go to step 22. If voltage is not present, go to step 21.

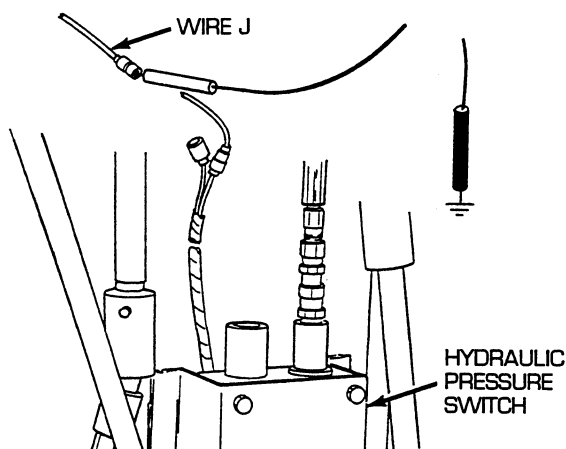

CORRECTIVE ACTION –Continued

21. Reconnect wire J to hydraulic pressure switch. Disconnect wire J of bulkhead to engine wiring harness and starter relay wiring harness from bulkhead to APU, master relay, and rigger's lights wiring harness. Place red lead of multimeter on male connector of wire J and black lead to ground. Turn MASTER and APU GEN switches ON and check for voltage. Turn MASTER and APU GEN switches OFF. If voltage is present, repair/replace wire J of bulkhead to APU, master relay, and rigger's lights wiring harness (see WP 0225 00). If voltage is not present, repair/replace wire J of bulkhead to engine wiring harness and starter relay wiring harness to bulkhead disconnect (see WP 0221 00).

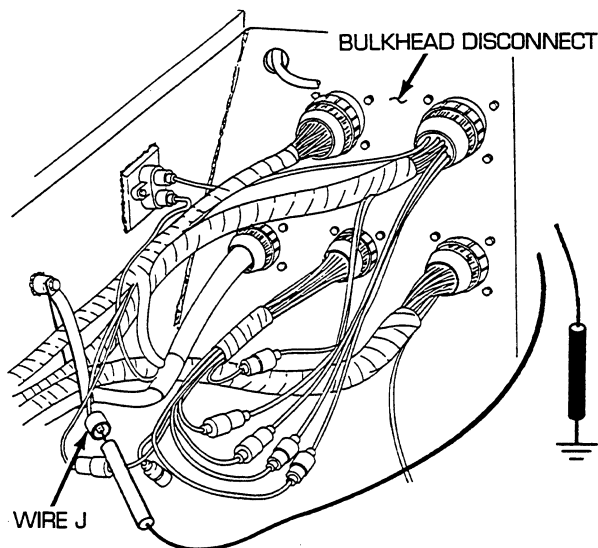

22. Reconnect wire J to hydraulic pressure switch. Disconnect wire H from hydraulic pressure switch. Place red lead of multimeter on wire H and black lead to ground. Turn MASTER and APU GEN switches ON and check for voltage. If voltage is present, go to step 23. If voltage is not present, replace hydraulic pressure switch (see WP 0432 00).

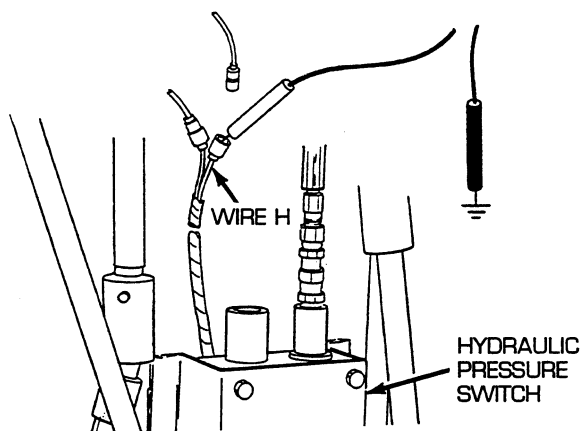

CORRECTIVE ACTION –Continued

23. Reconnect wire H to hydraulic pressure switch. Disconnect bulkhead to APU, master relay, and rigger's lights wiring harness from APU engine disconnect. Place red lead of multimeter in socket F of wire 61 and black lead to ground. Turn MASTER, APU pressure, and APU GEN switches ON and check for voltage. Turn MASTER, APU pressure, and APU GEN switches OFF. If voltage is present, notify Direct Support Maintenance. If voltage is not present, repair/replace wire 61 of bulkhead to APU, master relay, and rigger's lights wiring harness (see WP 0225 00).

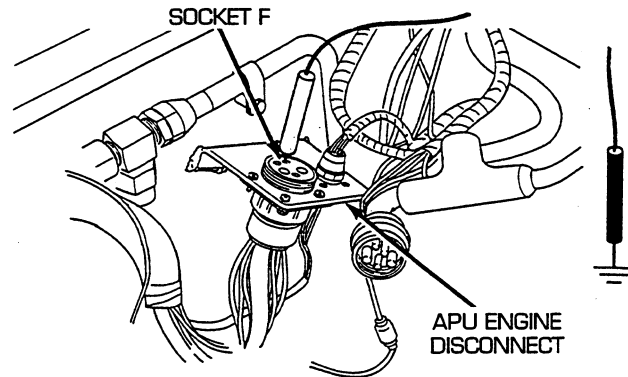
**END OF WORK PACKAGE**

UNIT MAINTENANCE
RECOVERY VEHICLE, FULL TRACKED: MEDIUM, M88A1
NSN 2350-00-122-6826, EIC AQA
GENERATOR INDICATOR GAGE TROUBLESHOOTING PROCEDURE

INITIAL SETUP:**Tools and Special Tools**

Tool kit, general mechanic's (item 59, WP 0490 00)

References

WP 0042 00
WP 0157 00
WP 0159 00
WP 0193 00

References (cont.)

WP 0194 00
WP 0195 00
WP 0202 00
WP 0204 00
WP 0205 00
WP 0218 00

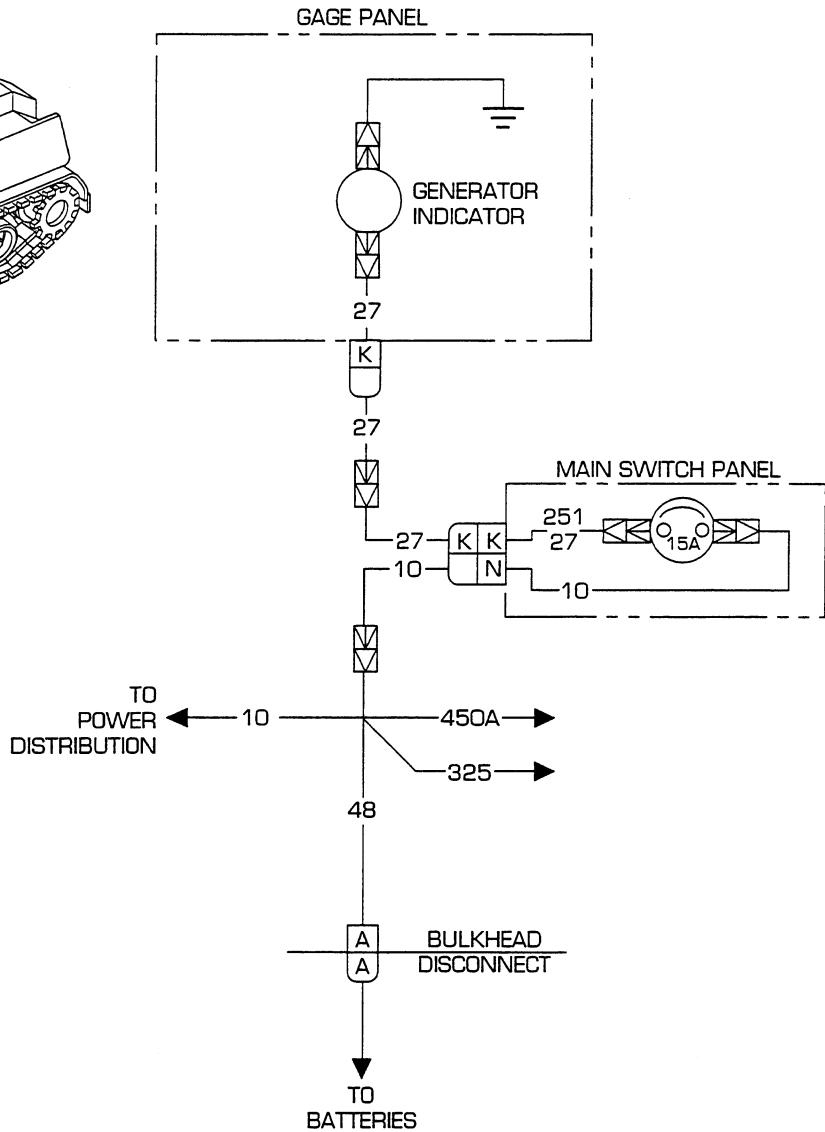
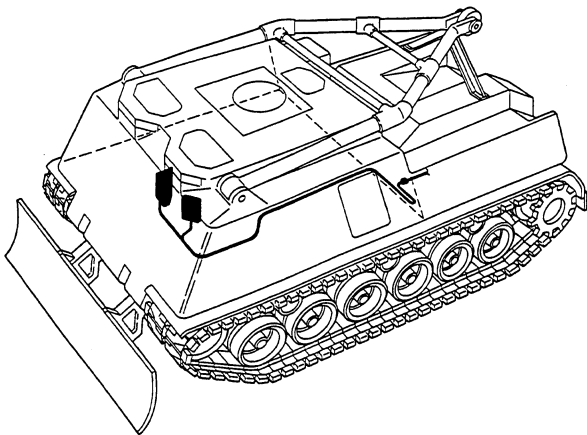

Troubleshooting Procedure

Generator Indicator Gage

Symptom

Generator indicator gage malfunctioning.

Malfunction

Generator indicator gage fails to operate when MASTER switch is on. Do steps 1 thru 8.

CORRECTIVE ACTION**WARNING**

Remove all jewelry such as rings, dog tags, bracelets, etc. If jewelry contacts a metal surface a direct short may result in instant heating of tools, damage to equipment, and injury or death to personnel.

1. Remove three screws (1), three lockwashers (2), two screws (3), two lockwashers (4), and ground strap (5) and release gage panel (6) from mounting brackets. Disconnect gage panel to bulkhead wiring harness from gage panel. Place red lead of multimeter in pin K of wire 27 and black lead to ground. Turn MASTER switch on and check for voltage. Turn MASTER switch OFF. If voltage is present, go to step 2. If voltage is not present, go to step 3.

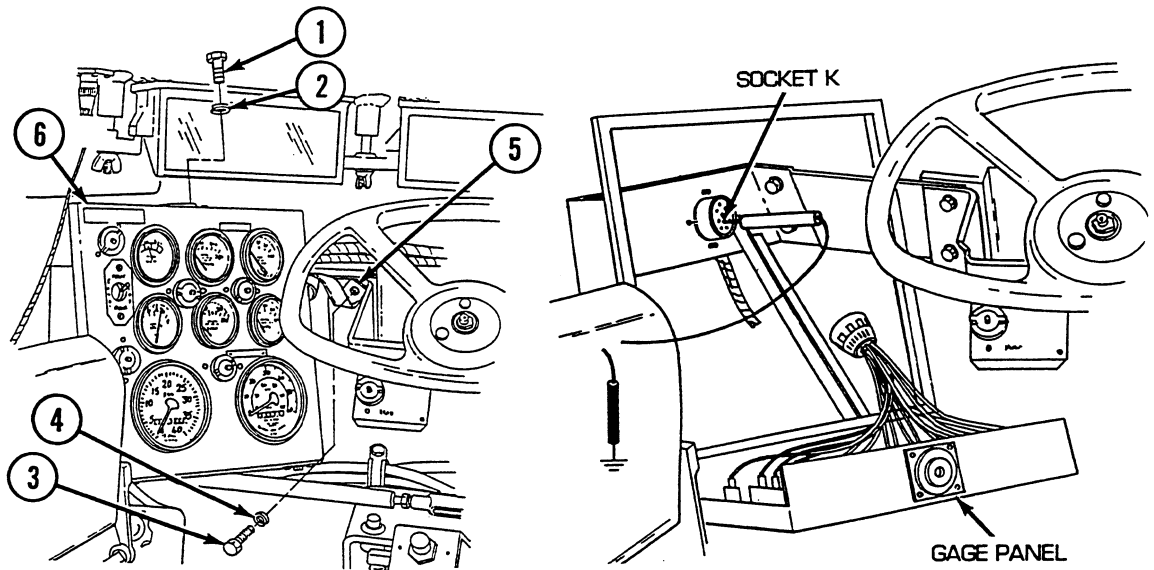

CORRECTIVE ACTION –Continued

2. Reconnect gage panel to bulkhead wiring harness to gage panel. Disconnect wire 27B from generator indicator gage. Place red lead of multimeter in wire 27B and black lead to ground. Turn MASTER switch on and check for voltage. Turn MASTER switch OFF. If voltage is present, replace generator indicator gage (see WP 0157 00). If voltage is not present, repair/replace wire 27B from connector to generator indicator gage of gage panel wiring harness (see WP 0193 00).

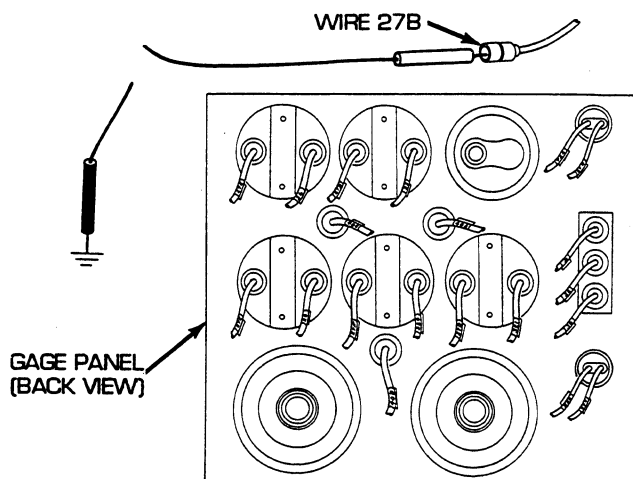

3. Reconnect gage panel to bulkhead wiring harness to gage panel. Install ground strap (5), two lockwashers (4), two screws (3), gage panel (6), three lockwashers (2), and three screws (1) to mounting brackets.

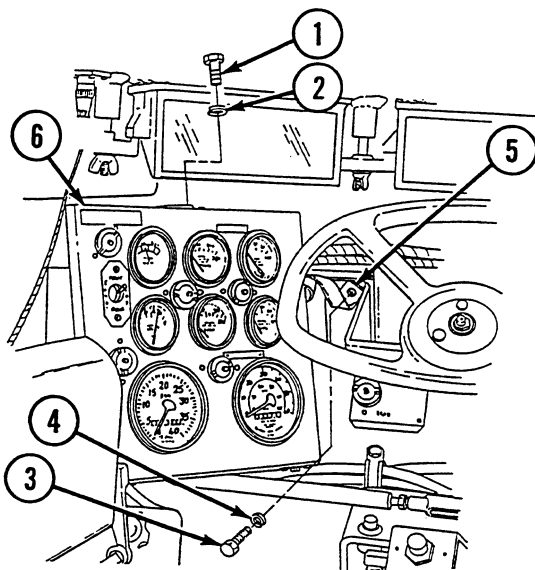

Remove three screws (7), three lockwashers (8), ground wire (9), flat washer (10), and release main switch panel (11) from mounting brackets. Disconnect switch panel to gage panel and miscellaneous switches wiring harness from main switch panel. Place a jumper wire from pin N to socket N. Place

CORRECTIVE ACTION –Continued

red lead of multimeter in socket K of wire 27 and black lead to ground. Turn MASTER switch on and check for voltage. Turn MASTER switch OFF. If voltage is present, go to step 4. If voltage is not present, go to step 5.

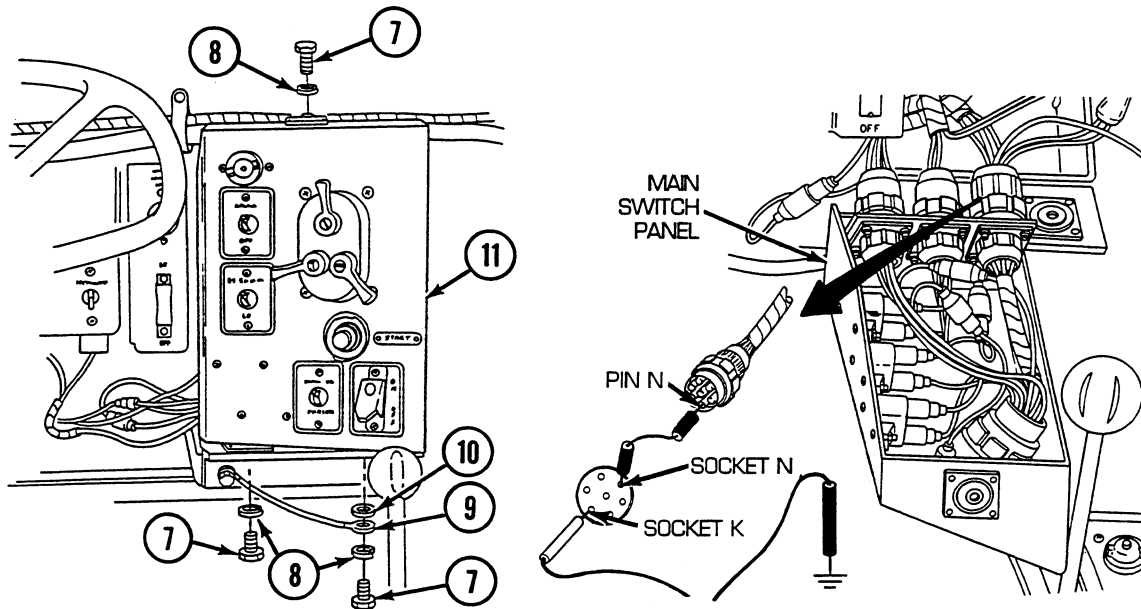

4. Reconnect switch panel to gage panel and miscellaneous switches wiring harness to main switch panel. Disconnect wire 27 at connector near gage panel. Place red lead of multimeter in female connector of wire 27 and black lead to ground. Turn MASTER switch on and check for voltage. Turn MASTER switch OFF. If voltage is present, repair/replace wire 27 of gage panel to bulkhead wiring harness (see WP 0194 00 for dual voltage; 0195 00 for single voltage). If voltage is not present, repair/replace wire 27 to switch panel to gage panel and miscellaneous switches wiring harness (see WP 0204 00 for dual voltage; 0205 00 for single voltage).

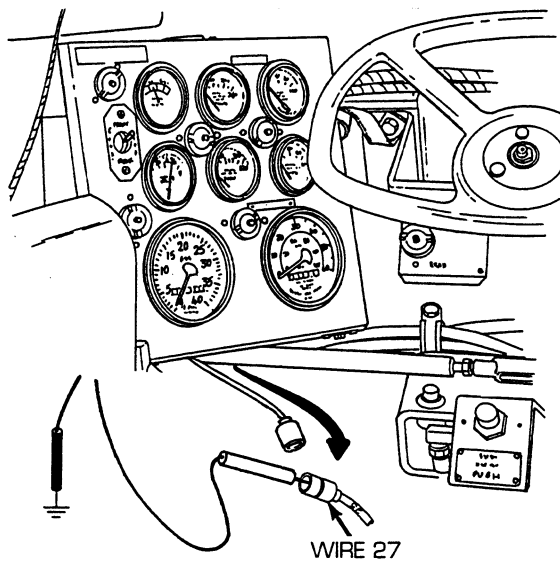

CORRECTIVE ACTION –Continued

5. Place red lead of multimeter on pin N of wire 10/15 and black lead to ground. Turn MASTER switch on and check for voltage. Turn MASTER switch OFF. If voltage is present, go to step 6. If voltage is not present, go to step 8.

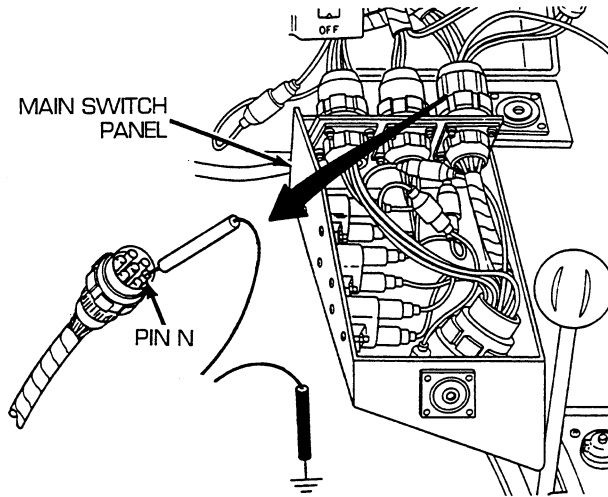

6. Reconnect switch panel to gage panel and miscellaneous switches wiring harness to main switch panel. Disconnect wire 25/27 from 15 A circuit breaker. Place red lead of multimeter on circuit breaker terminal and black lead to ground. Turn MASTER switch on and check for voltage. Turn MASTER switch OFF. If voltage is present, repair/replace wire 27 of main lighting and B.O. selector switch wiring harness (see WP 0218 00). If voltage is not present, go to step 7.

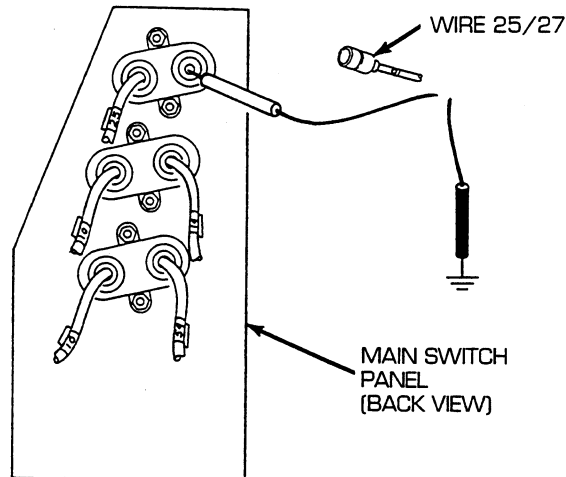

CORRECTIVE ACTION –Continued

7. Reconnect wire 25/27 to 15 A circuit breaker. Disconnect wire 10 from 15 A circuit breaker. Place red lead of multimeter in wire 10 and black lead to ground. Turn MASTER switch on and check for voltage. Turn MASTER switch OFF. If voltage is present, replace 15 A circuit breaker (see WP 0159 00). If voltage is not present, repair/replace wire 10 of main lighting and B.O. selector switch wiring harness (see WP 0218 00).

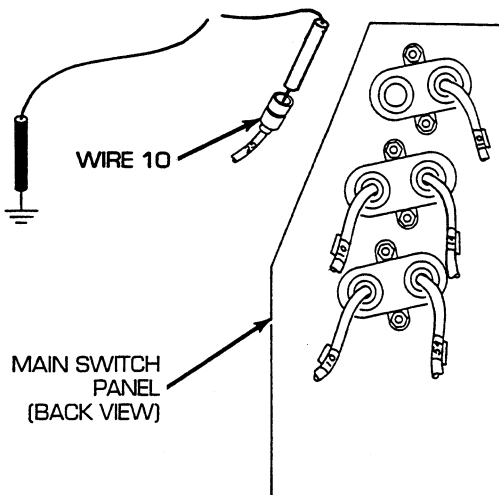

8. Reconnect switch panel to gage panel and miscellaneous switches wiring harness to main switch panel. Install main switch panel (11), flat washer (10), ground wire (9), three lockwashers (8), and three screws (7) to mounting brackets. Disconnect wire 48 pin A from bulkhead to master relay wiring harness. Place red multimeter lead in socket and black lead to ground. Turn MASTER switch on and check for voltage. If voltage is present, repair/replace switch panel, radio, and bilge pump to bulkhead wiring harness (see WP 0202 00). If voltage is not present, troubleshoot master relay circuit (see WP 0042 00).

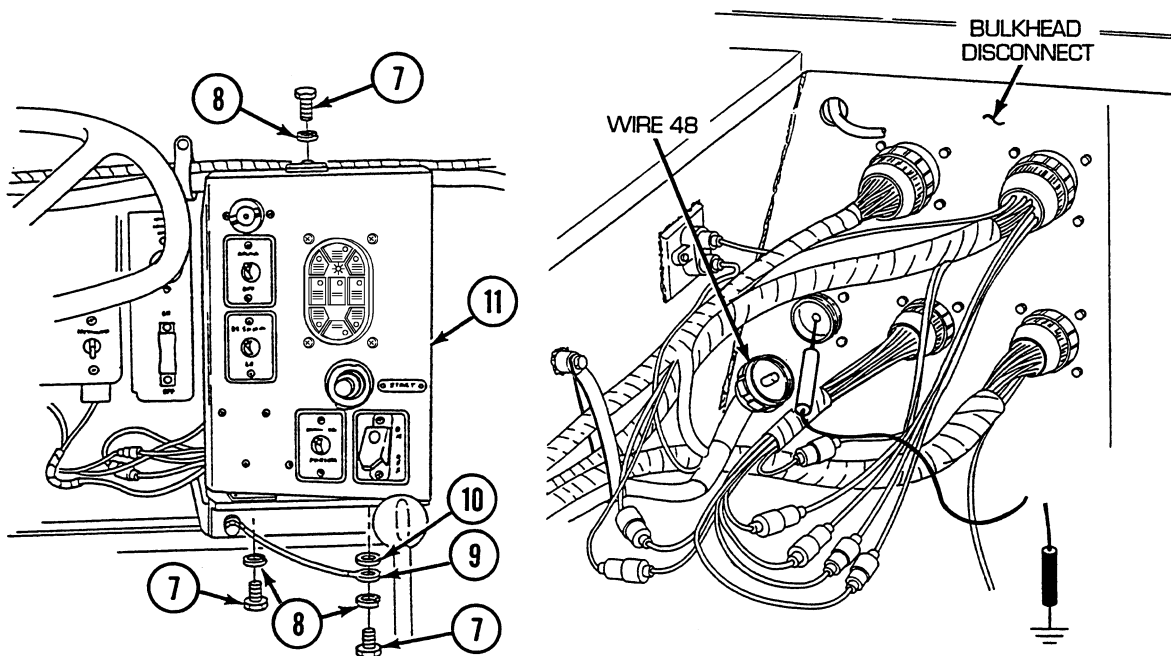

END OF WORK PACKAGE

UNIT MAINTENANCE
RECOVERY VEHICLE, FULL TRACKED: MEDIUM, M88A1
NSN 2350-00-122-6826, EIC AQA
APU STARTING SYSTEM TROUBLESHOOTING PROCEDURE

INITIAL SETUP:**Tools and Special Tools**

Tool kit, general mechanic's (item 59, WP 0490 00)

References

WP 0228 00

References (cont.)

WP 0229 00

WP 0438 00

TM 9-2350-256-10

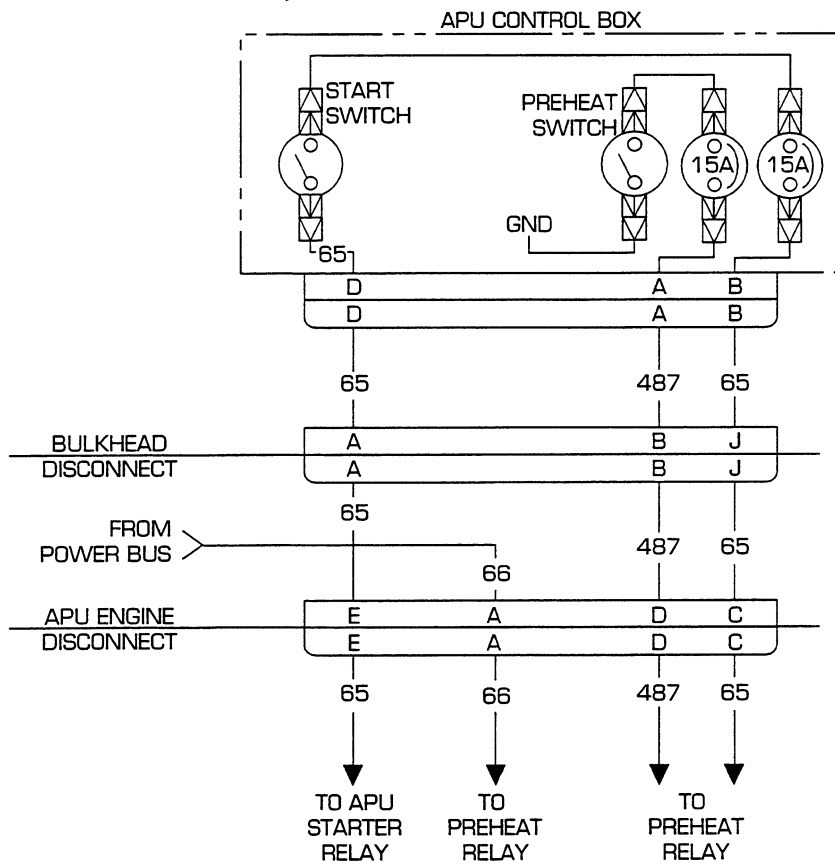
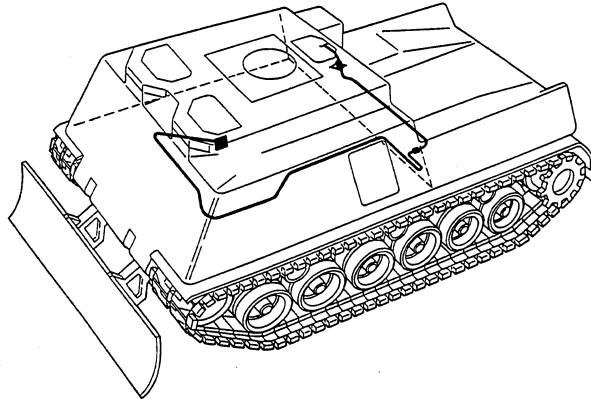

Troubleshooting Procedure

APU Starting System

Symptom

APU starting system malfunctioning.

Malfunction

APU starter fails to crank or is hard to start in cold weather. Do steps 1 thru 13.

CORRECTIVE ACTION**WARNING**

Remove all jewelry such as rings, dog tags, bracelets, etc. If jewelry contacts a metal surface a direct short may result in instant heating of tools, damage to equipment, and injury or death to personnel.

1. Open center-front air inlet doors (TM 9-2350-256-10). Disconnect bulkhead to APU, master relay, and rigger's lights wiring harness from APU engine disconnect. Place red lead of multimeter in socket A of wire 66 and black lead to ground. Turn MASTER, and PREHEAT switches on and check for voltage. Turn MASTER and PREHEAT switches OFF. If voltage is present, go to step 2. If voltage is not present, troubleshoot battery circuit.

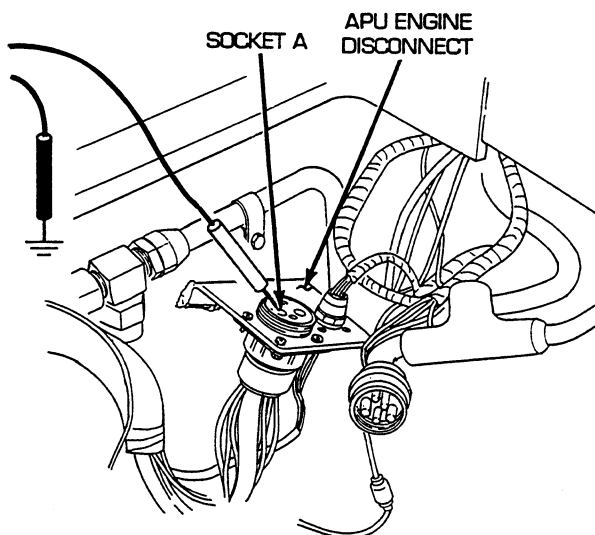

2. Place red lead of multimeter in socket E of wire 65 and black lead to ground. Turn MASTER, PREHEAT, and APU START switches on and check for voltage. Turn MASTER, PREHEAT, and APU START switches OFF. If voltage is present, go to step 3. If voltage is not present, go to step 4.

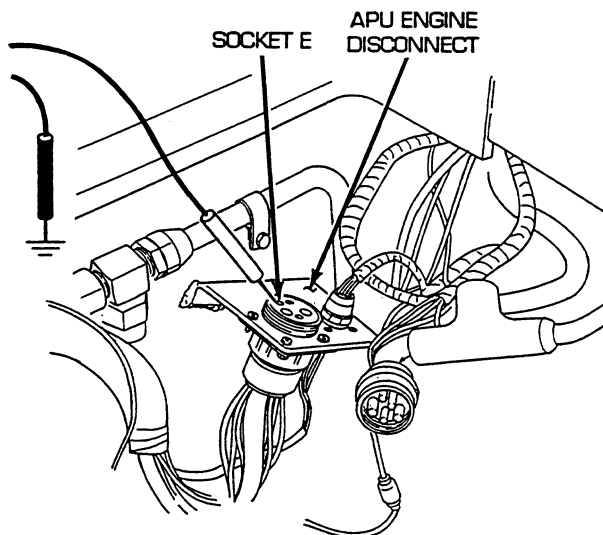

CORRECTIVE ACTION –Continued

- Place red lead of multimeter in socket D of wire 487 and black lead to ground. Turn MASTER and PREHEAT switches ON and check for voltage. Turn MASTER and PREHEAT switches OFF. If voltage is present, notify Direct Support Maintenance. If voltage is not present, go to step 5.

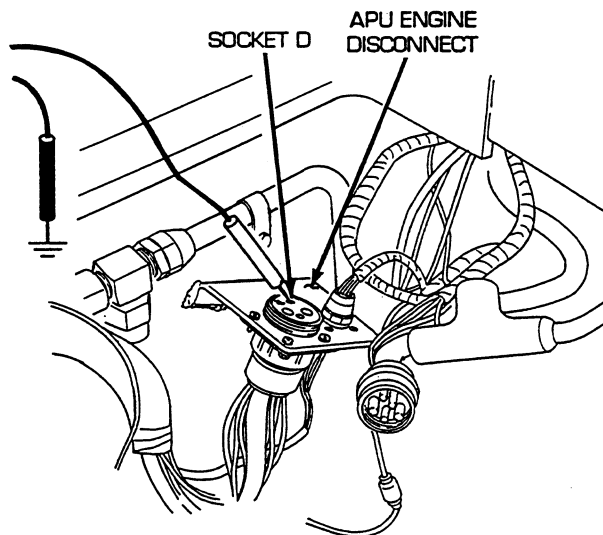

- Reconnect bulkhead to APU, master relay, and rigger's lights wiring harness to APU engine disconnect. Open air inlet doors (see TM 9-2350-256-10). Disconnect bulkhead to APU, master relay, and rigger's lights wiring harness from bulkhead disconnect. Place a jumper wire from pin B to socket B. Place red lead of multimeter in socket J of wire 65 and black lead to ground. Turn MASTER and PREHEAT switches ON and check for voltage. Turn MASTER and PREHEAT switches OFF. If voltage is present, repair/replace wire 65 of APU control box to foot dimmer switch and bulkhead wiring harness (see WP 0228 00 for dual voltage; 0229 00 for single voltage). If voltage is not present, reconnect bulkhead to APU, master relay, and rigger's lights wiring harness to bulkhead disconnect and go to step 5.

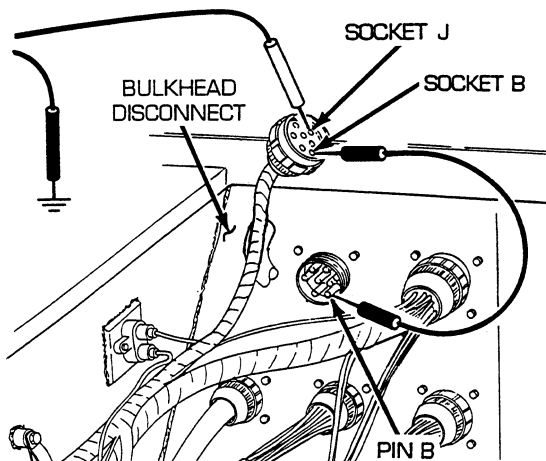

CORRECTIVE ACTION –Continued

5. Disconnect APU control box to foot dimmer switch and bulkhead wiring harness from APU control box. Remove four nuts (1), four lockwashers (2), and four screws (3), and release APU control box (4) from mounting bracket. Remove four screws (5) and four lockwashers (6), and release rear panel (7) from APU control box. Reconnect APU control box to foot dimmer switch and bulkhead wiring harness to APU control box.

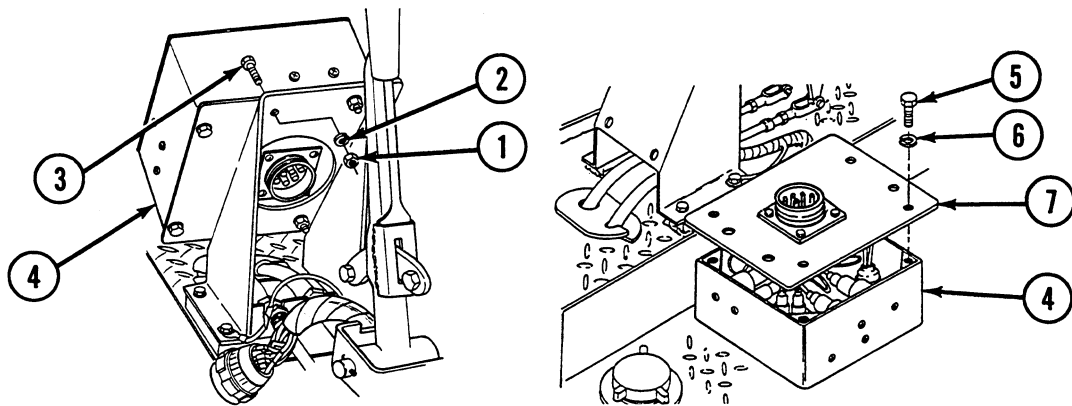

Disconnect wire 65 from START switch. Place red lead of multimeter on terminal of START switch and black lead to ground. Turn MASTER, PREHEAT and APU START switches ON and check for voltage. Turn MASTER, PREHEAT and APU START switches OFF. If voltage is not present, go to step 6. If voltage is present, repair/replace wire 65 of APU control box wiring harness (see WP 0438 00).

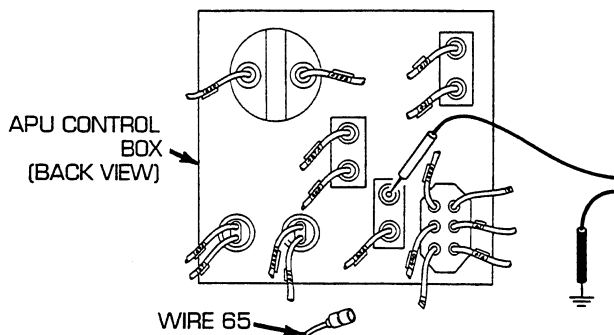

CORRECTIVE ACTION –Continued

6. Reconnect wire 65 to APU START switch. Disconnect wire 65A from APU START switch. Place red lead of multimeter in wire 65A and black lead to ground. Turn MASTER and PREHEAT switches ON, and check for voltage. Turn MASTER and PREHEAT switches OFF. If voltage is not present, go to step 7. If voltage is present, replace START switch (see WP 0438 00).

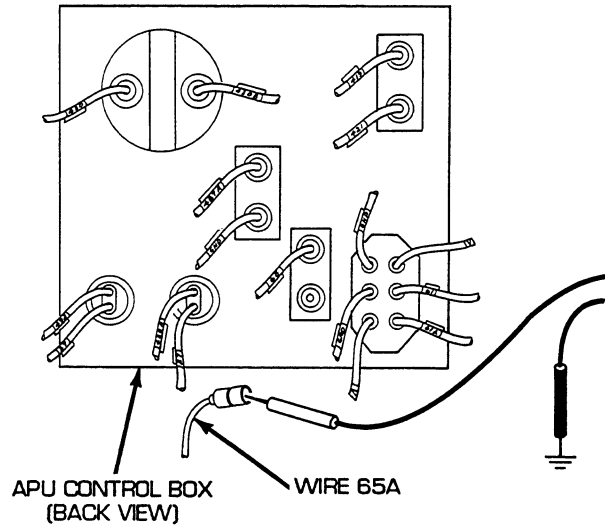

7. Reconnect wire 65A to APU START switch. Disconnect wire 65A from APU START switch side of 15 A circuit breaker. Place red lead of multimeter on terminal of 15 A circuit breaker and black lead to ground. Turn MASTER, and PREHEAT switches ON and check for voltage. Turn MASTER, and PREHEAT switches OFF. If voltage is not present, go to step 8. If voltage is present, repair/replace wire 65A of APU control box wiring harness (see WP 0438 00).

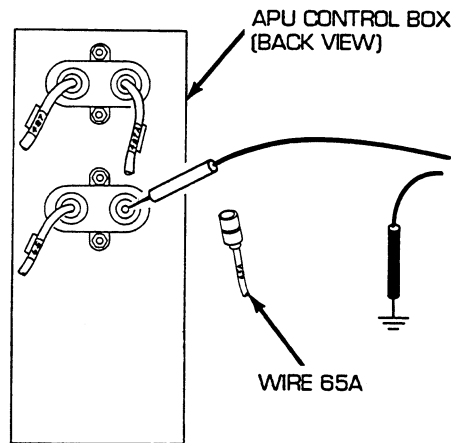

CORRECTIVE ACTION –Continued

8. Reconnect wire 65A to APU START switch side of circuit breaker. Disconnect wire 65 from panel connector side of 15 A circuit breaker. Place red lead of multimeter in wire 65 and black lead to ground. Turn MASTER and PREHEAT switches ON, and check for voltage. Turn MASTER and PREHEAT switches OFF. If voltage is not present, go to step 9. If voltage is present, replace 15 A circuit breaker (see WP 0438 00).

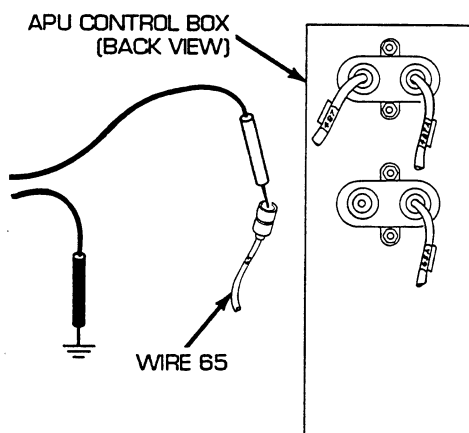

9. Disconnect APU control box to foot dimmer switch and bulkhead wiring harness from APU control box. Place red lead of multimeter in socket B of wire 65 and black lead to ground. Turn MASTER and PREHEAT switches on, and check for voltage. Turn MASTER and PREHEAT switches OFF. If voltage is present, repair/replace wire 65 of APU control box. If voltage is not present, go to step 10.

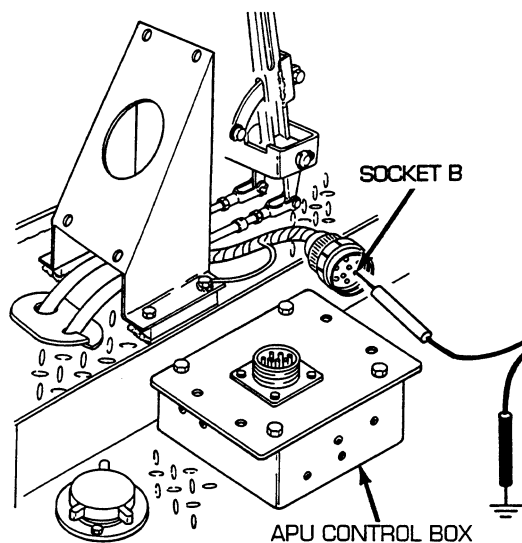

CORRECTIVE ACTION –Continued

10. Reconnect APU control box to foot dimmer switch and bulkhead wiring harness to APU control box. Disconnect wire 487 from 15 A circuit breaker. Place red lead of multimeter on terminal of 15 A circuit breaker and black lead to ground. Turn MASTER and PREHEAT switches ON, and check for voltage. Turn MASTER and PREHEAT switches OFF. If voltage is present, repair/replace wire 487 of APU control box wiring harness (see WP 0438 00). If voltage is not present, go to step 11.

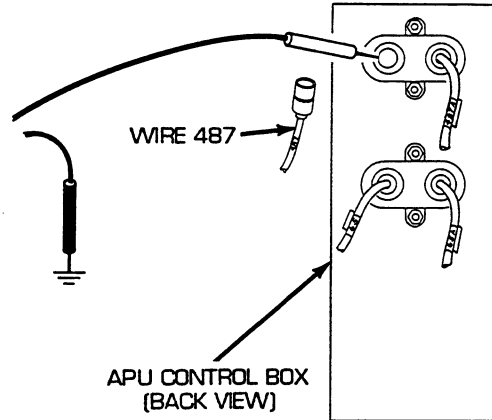

11. Reconnect wire 487 to 15 A circuit. Disconnect wire 487A from PREHEAT switch side of 15 A circuit breaker. Place red lead of multimeter in wire 487A and black lead to ground. Turn MASTER and PREHEAT switches ON, and check for voltage. Turn MASTER and PREHEAT switches OFF. If voltage is present, replace circuit breaker (see WP 0438 00). If voltage is not present, go to step 12.

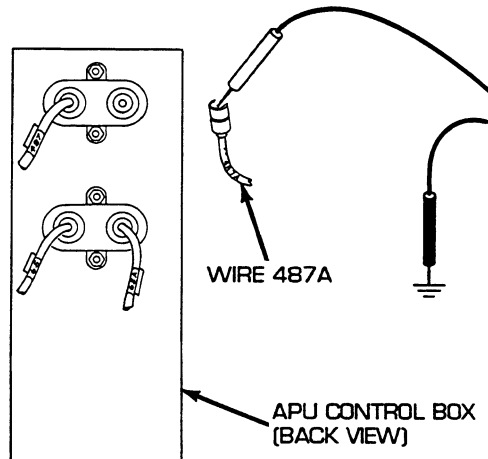

CORRECTIVE ACTION –Continued

12. Reconnect wire 487A to PREHEAT switch side of circuit breaker. Disconnect wire 487A from PREHEAT switch. Place red lead of multimeter on terminal of preheat switch and black lead to ground. Turn MASTER and PREHEAT switches ON, and check for voltage. Turn MASTER and PREHEAT switches OFF. If voltage is present, repair/replace wire 487A of APU control box wiring harness (see WP 0438 00). If voltage is not present, go to step 13.

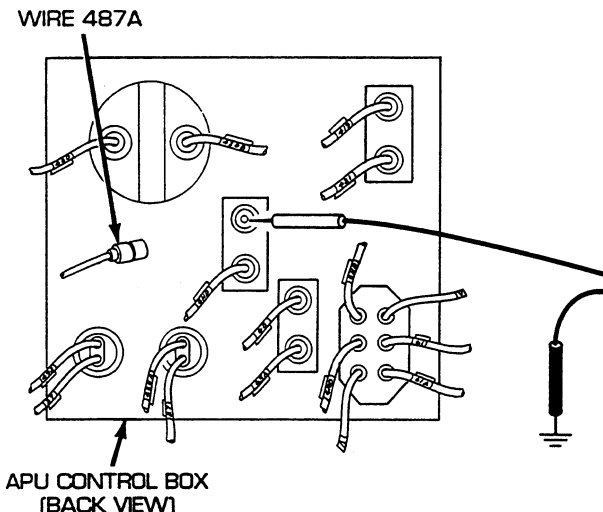

13. Reconnect wire 487A to PREHEAT switch. Disconnect GND wire from PREHEAT switch. Place red lead of multimeter in GND wire and black lead to ground. Turn MASTER and APU GEN switches ON and check for voltage. Turn MASTER and APU GEN switches OFF. If voltage is present, replace PREHEAT switch (see WP 0438 00). If voltage is not present, replace GND wire of APU control box wiring harness (see WP 0438 00).

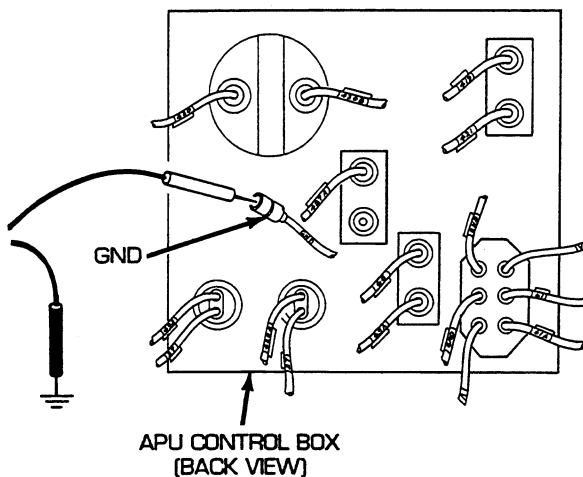

END OF WORK PACKAGE

UNIT MAINTENANCE
RECOVERY VEHICLE, FULL TRACKED: MEDIUM, M88A1
NSN 2350-00-122-6826, EIC AQA
APU FUEL SOLENOID SYSTEM TROUBLESHOOTING PROCEDURE

INITIAL SETUP:**Tools and Special Tools**

Tool kit, general mechanic's (item 59, WP 0490 00)

References

WP 0042 00

WP 0202 00

WP 0224 00

References (cont.)

WP 0225 00

WP 0228 00

WP 0229 00

WP 0438 00

TM 9-2350-256-10

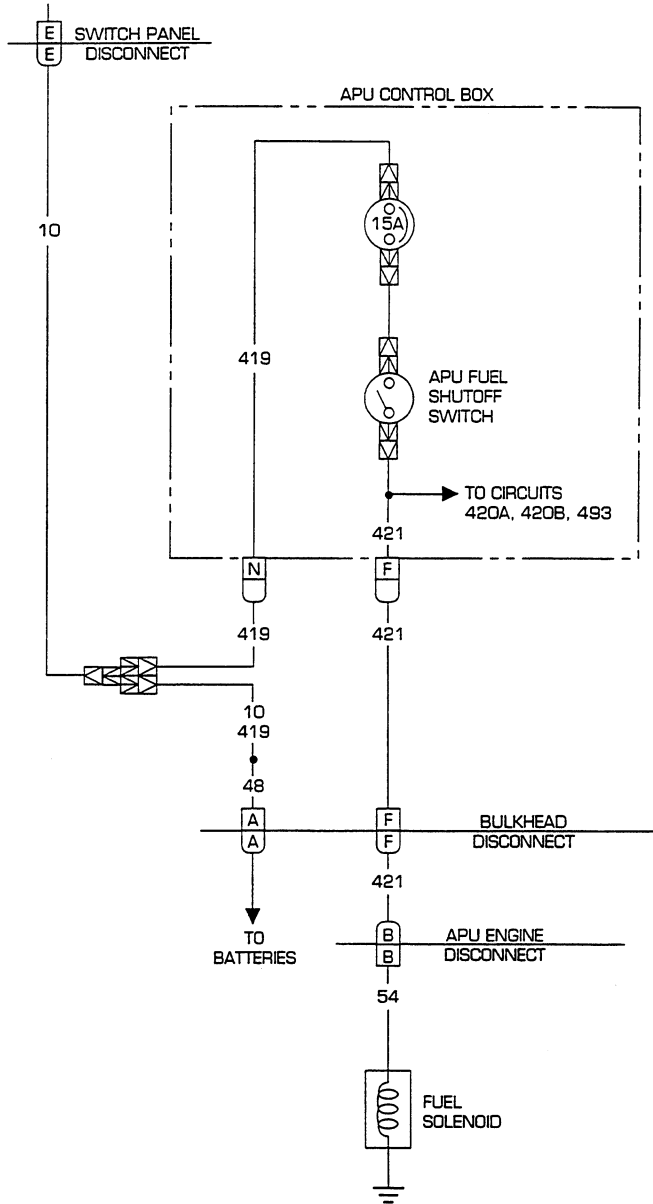
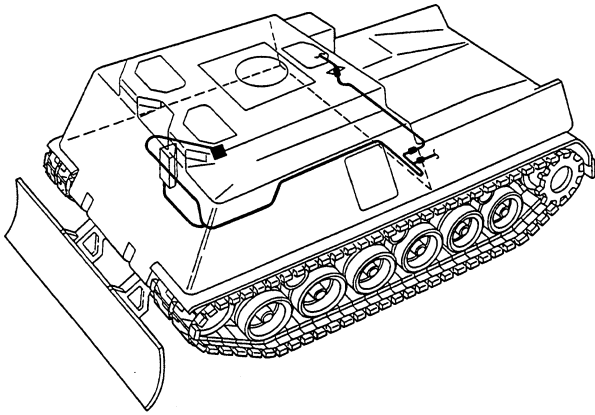

Troubleshooting Procedure**APU Fuel Solenoid System****Symptom**

APU fuel solenoid malfunctioning.

Malfunction

APU fuel solenoid fails to operate. Do steps 1 thru 10.

CORRECTIVE ACTION**WARNING**

Remove all jewelry such as rings, dog tags, bracelets, etc. If jewelry contacts a metal surface a direct short may result in instant heating of tools, damage to equipment, and injury or death to personnel.

1. Disconnect APU control box to foot dimmer switch and bulkhead wiring harness from APU control box. Place red lead of multimeter in socket N of wire 419 and black lead to ground. Turn MASTER switch on and check for voltage. Turn MASTER switch OFF. If voltage is present, go to step 4. If voltage is not present, go to step 2.

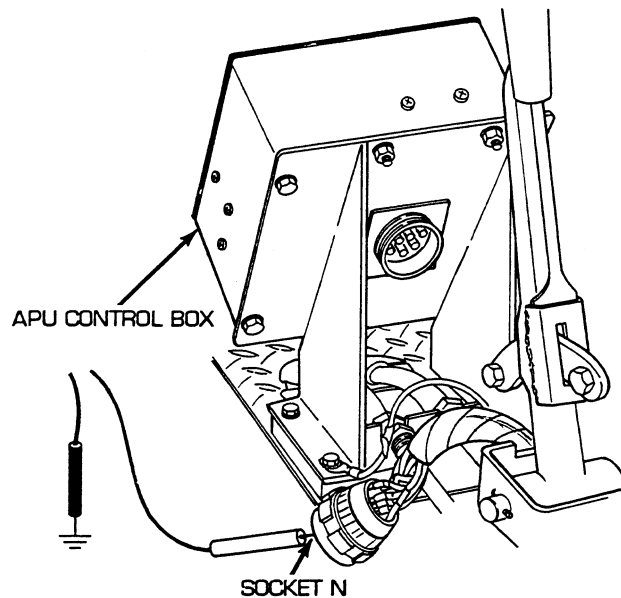

CORRECTIVE ACTION –Continued

2. Connect APU control box to foot dimmer switch and bulkhead wiring harness to APU control box. Remove three screws (1), three lockwashers (2), ground wire (3), and flat washer (4), and release main switch panel (5) from mounting bracket. Disconnect wire 10-419 from Y-connector of switch panel, radio, and bilge pump to bulkhead wiring harness at main switch panel. Turn MASTER switch on, and check for voltage. If voltage is present, repair wire 419 from Y-connector at main switch panel to APU control box bulkhead wiring harness. If voltage is not present, go to step 3.

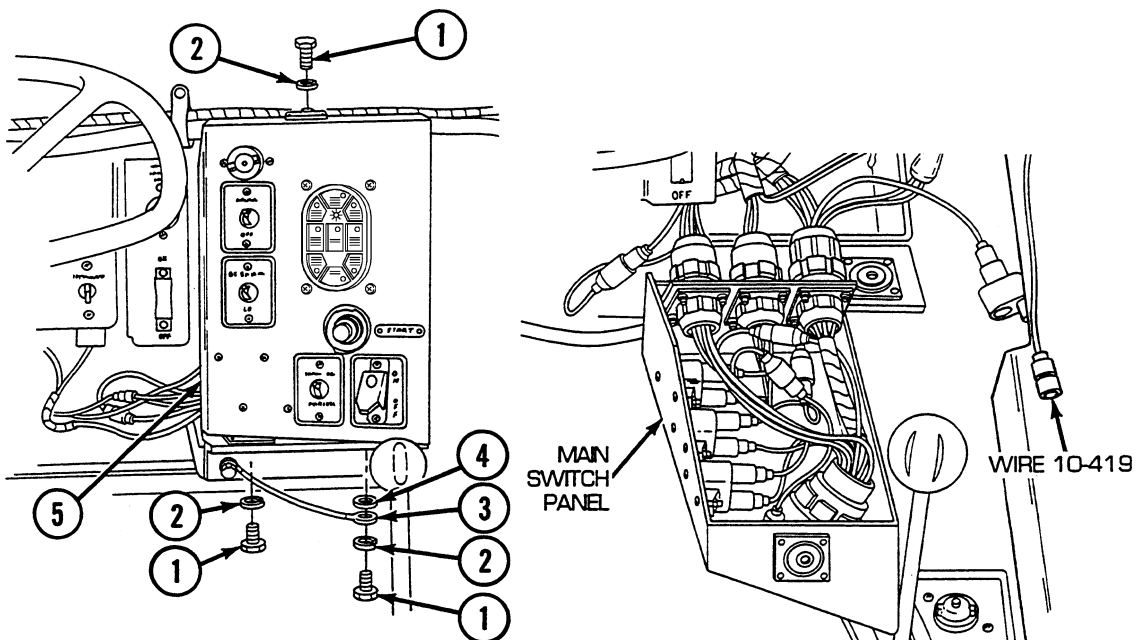

3. Reconnect wire 10-419 to Y-connector of switch panel, radio, and bilge pump to bulkhead wiring harness to main switch panel. Install main switch panel (5), flat washer (4), ground wire (3), three lockwashers (2), and three screws (1) to mounting bracket. Open air inlet doors (TM 9-2350-256-10). Disconnect wire 48 pin A from bulkhead to master relay wiring harness. Place red multimeter lead in socket and black lead to ground. Turn MASTER switch on and check for voltage. If voltage is present, repair/replace switch panel, radio, and bilge pump to bulkhead wiring harness (see WP 0202 00). If voltage is not present, troubleshoot master relay circuit (see WP 0042 00).

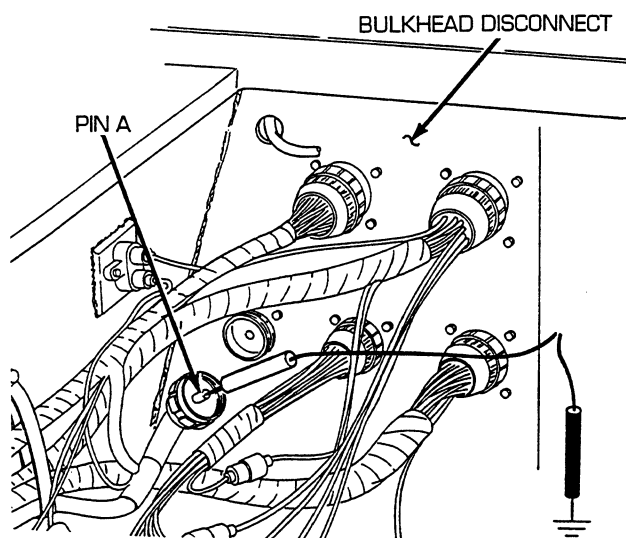

CORRECTIVE ACTION –Continued

4. Remove four nuts (6), four lockwashers (7), four screws (8), and release APU control box (9) from mounting bracket. Place a jumper wire from pin N to socket N. Place red lead of multimeter on pin F of wire 421 and black lead to ground. Turn MASTER and APU FUEL SHUTOFF switches ON, and check for voltage. Turn MASTER and APU FUEL SHUTOFF switches OFF. If voltage is present, go to step 9. If voltage is not present, go to step 5.

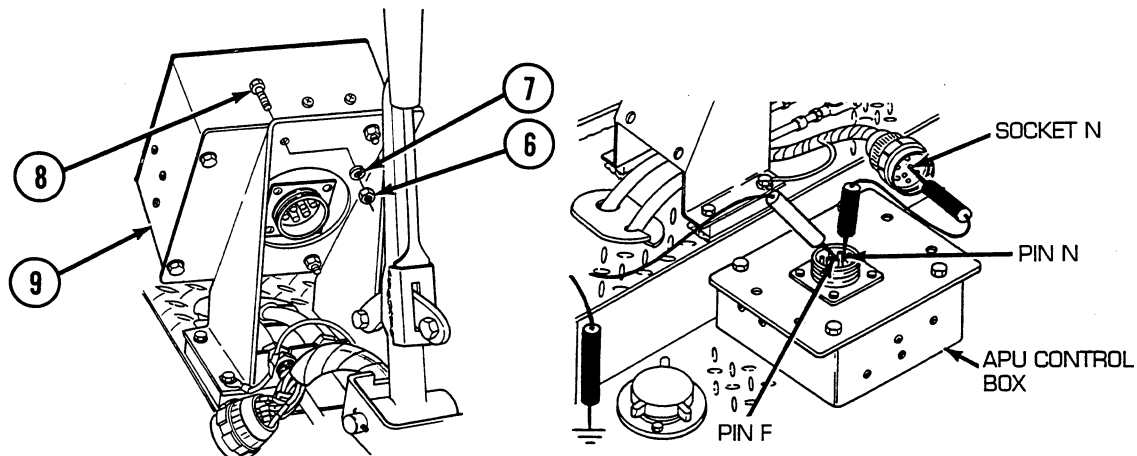

5. Remove four screws (10), four lockwashers (11), and release rear panel (12) from APU control box (9). Reconnect APU control box to foot dimmer switch and bulkhead wiring harness to APU control box. Disconnect wire 419 from 15 A circuit breaker. Place red lead of multimeter in wire 419 and black lead to ground. Turn MASTER switch on and check for voltage. Turn MASTER switch OFF. If voltage is present, go to step 6. If voltage is not present, repair/replace wire 419 of APU control box wiring harness from connector to circuit breaker (see WP 0438 00).

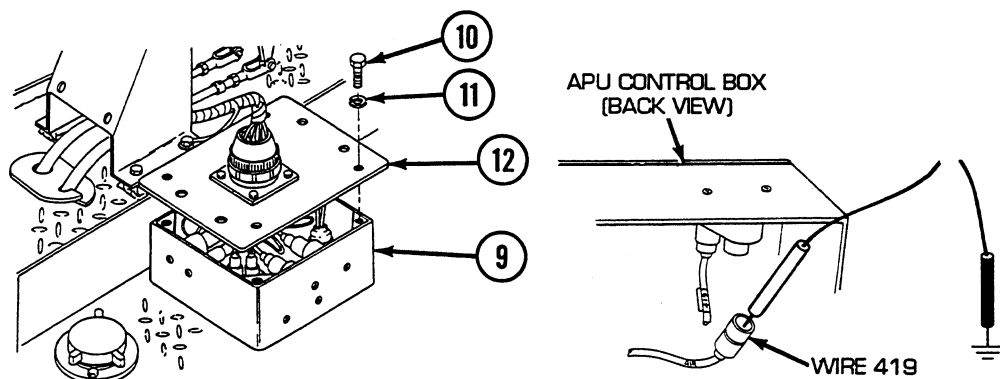

CORRECTIVE ACTION –Continued

6. Reconnect wire 419 to circuit breaker. Disconnect wire 419 from APU FUEL SHUTOFF switch side of 15 A circuit breaker. Place red lead of multimeter on terminal of circuit breaker and black lead to ground. Turn MASTER switch on and check for voltage. Turn MASTER switch OFF. If voltage is present, go to step 7. If voltage is not present, replace 15 A circuit breaker (see WP 0438 00).

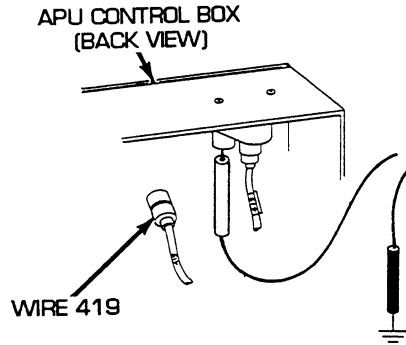

7. Reconnect wire 419 to APU fuel shutoff switch side of 15 A circuit breaker. Disconnect wire 419 from circuit breaker side of APU FUEL SHUTOFF switch. Place red lead of multimeter in wire 419 and black lead to ground. Turn MASTER switch on and check for voltage. Turn MASTER switch OFF. If voltage is present, go to step 8. If voltage is not present, repair/replace wire 419 of APU fuel shutoff switch lead assembly from circuit breaker to shutoff switch (see WP 0438 00).

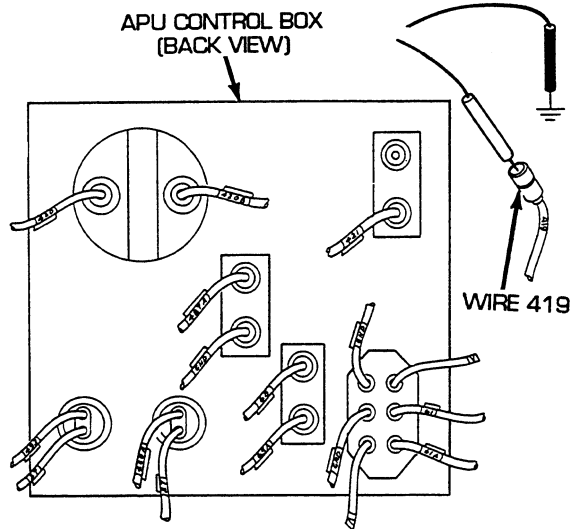

CORRECTIVE ACTION –Continued

8. Reconnect wire 419 to circuit breaker side of APU FUEL SHUTOFF switch. Disconnect wire 421 from APU FUEL SHUTOFF switch. Place red lead of multimeter on terminal of APU FUEL SHUTOFF switch and black lead to ground. Turn MASTER and APU FUEL SHUTOFF switches ON and check for voltage. Turn MASTER and APU FUEL SHUTOFF switches OFF. If voltage is present, repair/replace wire 421 of APU control box wiring harness (see WP 0438 00). If voltage is not present, replace APU FUEL SHUTOFF switch (see WP 0438 00).

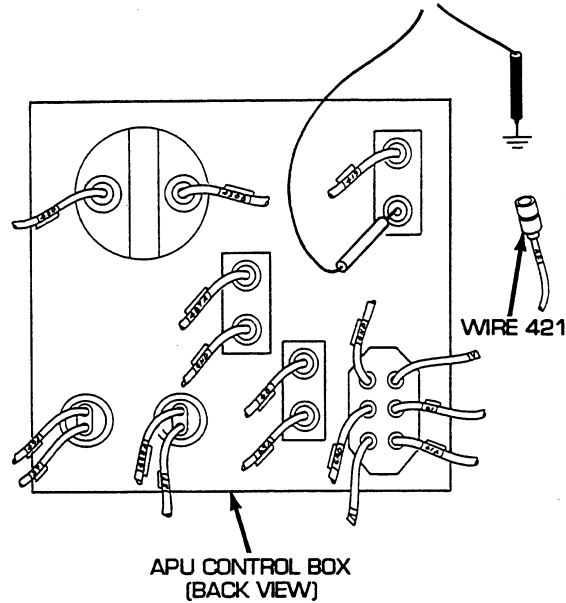

CORRECTIVE ACTION –Continued

9. Reconnect APU control box to foot dimmer switch and bulkhead wiring harness to APU control box. Install APU control box (9), four screws (8), four lockwashers (7), and four nuts (6) to mounting bracket. Open air inlet doors. Disconnect bulkhead to APU, master relay, and rigger's lights wiring harness from bulkhead disconnect. Place red lead of multimeter on pin F of wire 421 and black lead to ground. Turn MASTER and APU fuel shut-off switches ON and check for voltage. Turn MASTER and APU fuel shut-off switches OFF. If voltage is present, go to step 10. If voltage is not present, repair/replace wire 421 of APU control box to foot dimmer switch and bulkhead wiring harness (see WP 0228 00 for dual voltage; 0229 00 for single voltage).

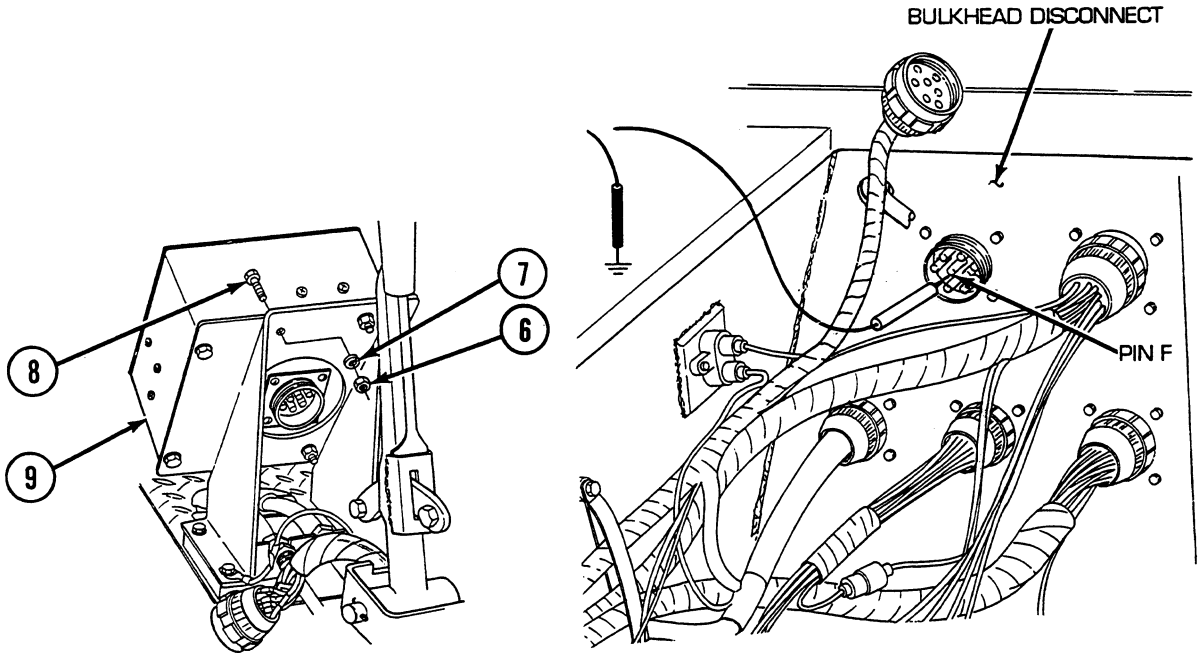

CORRECTIVE ACTION –Continued

10. Reconnect bulkhead to APU, master relay, and rigger's lights wiring harness to bulkhead disconnect. Open center-front air inlet doors (TM 9-2350-256-10). Disconnect bulkhead to APU, master relay, and rigger's lights wiring harness from APU engine disconnect. Place red lead of multimeter on pin B of wire 421 and black lead to ground. Turn MASTER and APU fuel shut-off switches ON and check for voltage. Turn MASTER and APU fuel shut-off switches OFF. If voltage is present, notify Direct Support Maintenance. If voltage is not present, repair/replace wire 421 of bulkhead to APU, master relay, and rigger's lights wiring harness (see WP 0224 00 for dual voltage; 0225 00 for single voltage).

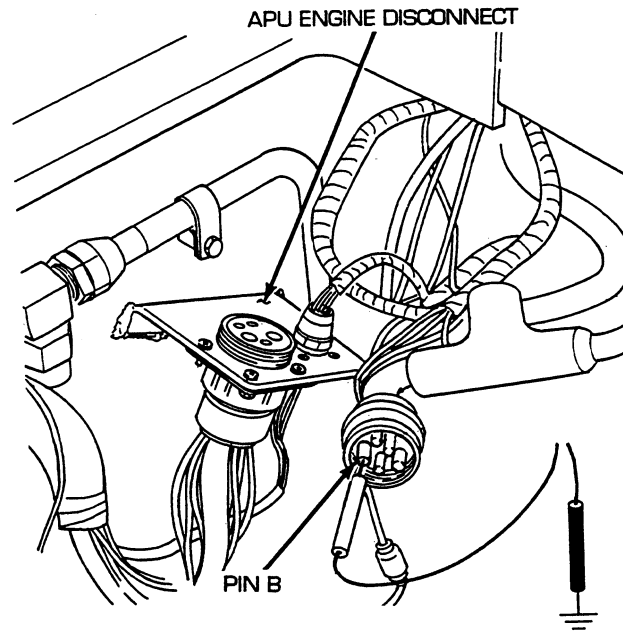
**END OF WORK PACKAGE**

UNIT MAINTENANCE
RECOVERY VEHICLE, FULL TRACKED: MEDIUM, M88A1
NSN 2350-00-122-6826, EIC AQA
APU LOW OIL PRESSURE SYSTEM TROUBLESHOOTING PROCEDURE

INITIAL SETUP:**Tools and Special Tools**

Tool kit, general mechanic's (item 59, WP 0490 00)

References

WP 0042 00
WP 0202 00
WP 0224 00

References (cont.)

WP 0225 00
WP 0228 00
WP 0229 00
WP 0438 00
TM 9-2350-256-10

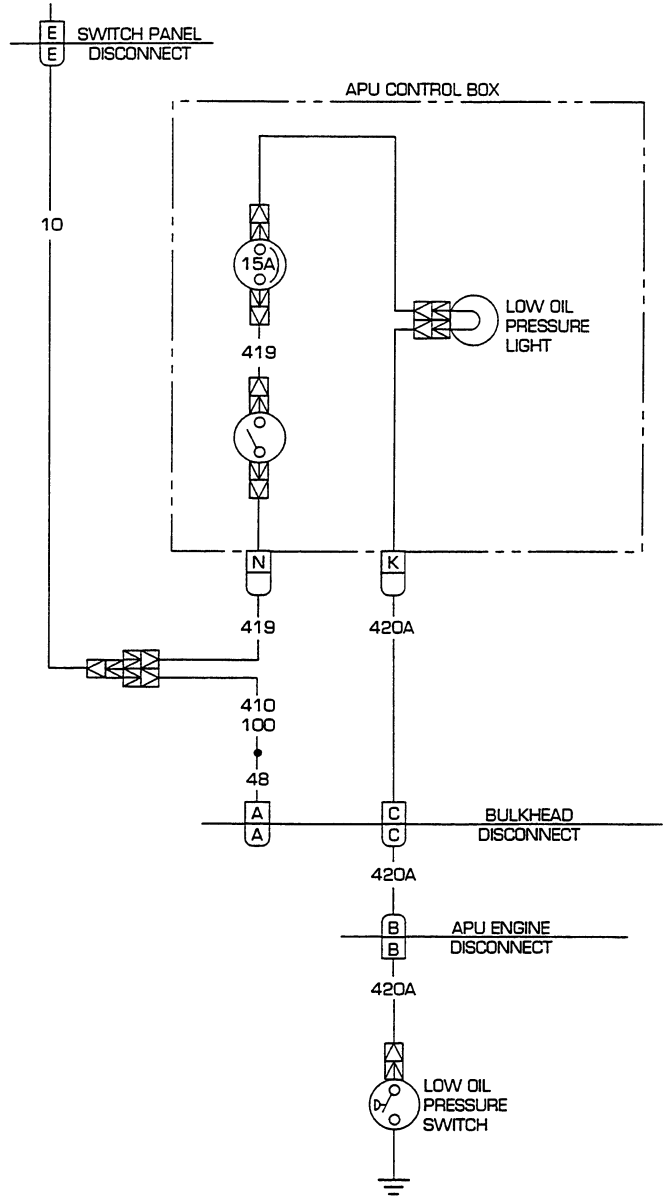
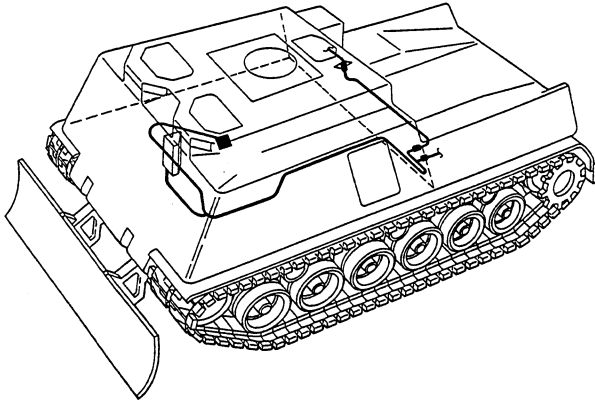

Troubleshooting Procedure

APU Low Oil Pressure System

Symptom

APU low oil pressure system malfunctioning.

Malfunction

APU low oil pressure lamp fails to light when APU is not running. Do steps 1 thru 13.

CORRECTIVE ACTION**WARNING**

Remove all jewelry such as rings, dog tags, bracelets, etc. If jewelry contacts a metal surface a direct short may result in instant heating of tools, damage to equipment, and injury or death to personnel.

1. Remove lamp from socket. Place red lead of multimeter in socket and black lead to ground. Turn MASTER and APU FUEL SHUTOFF switches ON, and check for voltage. Turn MASTER and APU FUEL SHUTOFF switches OFF. If voltage is present, replace lamp (see WP 0438 00). If voltage is not present, go to step 2.

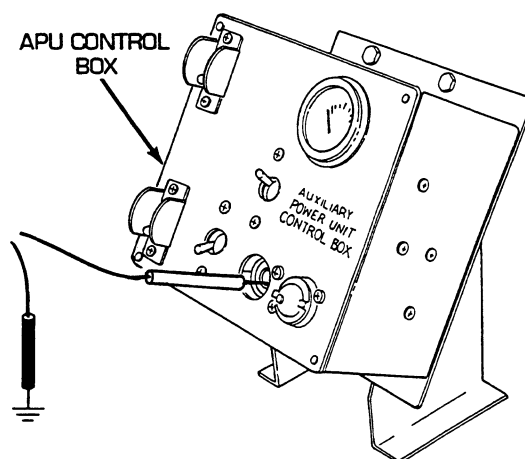

2. Disconnect APU control box to foot dimmer switch and bulkhead wiring harness from APU control box. Place red lead of multimeter in socket N of wire 419 and black lead to ground. Turn MASTER switch on and check for voltage. Turn MASTER switch OFF. If voltage is present, go to step 5. If voltage is not present, go to step 3.

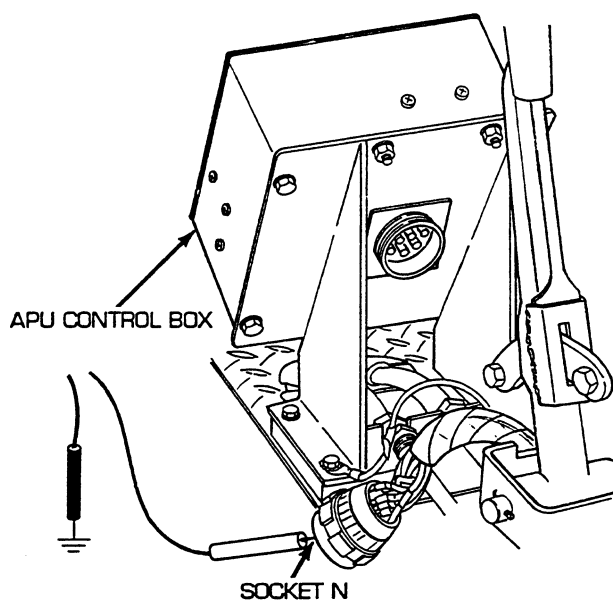

CORRECTIVE ACTION –Continued

3. Reconnect APU control box to dimmer switch and bulkhead wiring harness to APU control box. Remove three screws (1), three lockwashers (2), ground wire (3), and flat washer (4), and release main switch panel (5) from mounting bracket. Disconnect wire 10-419 from Y-connector of switch panel, radio, and bilge pump to bulkhead wiring harness at main switch panel. Turn MASTER switch on, and check for voltage. If voltage is present, repair wire 419 from Y-connector at main switch panel to APU control box bulkhead wiring harness. If voltage is not present, go to step 4.

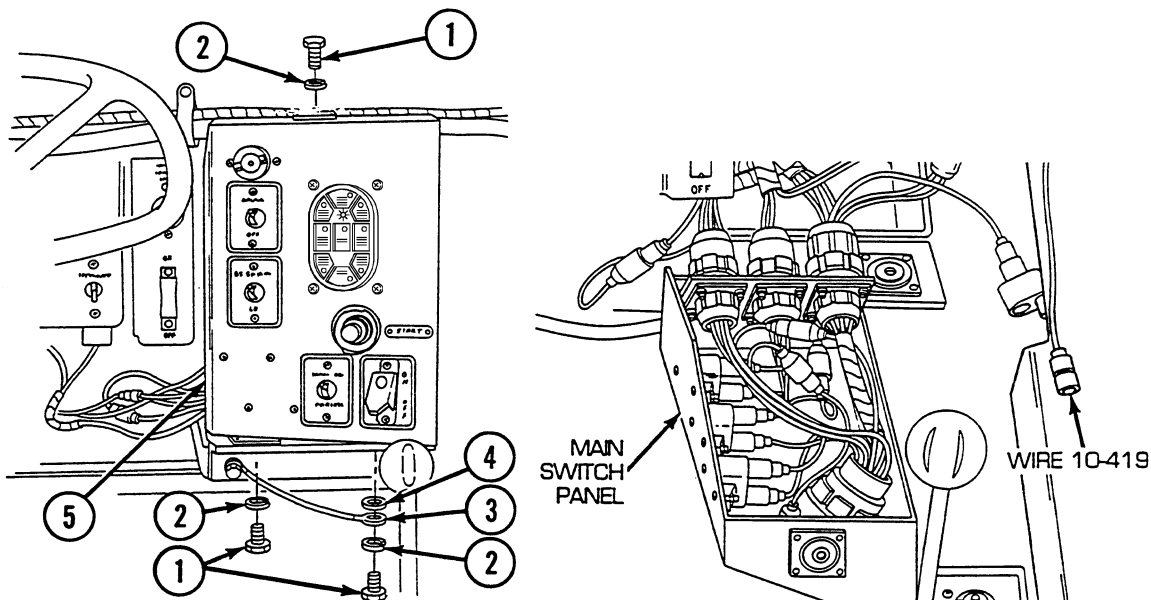

4. Reconnect wire 10-419 to Y-connector of switch panel, radio, and bilge pump to bulkhead wiring harness to main switch panel. Install main switch panel (5), flat washer (4), ground wire (3), three lockwashers (2), and three screws (1) to mounting bracket. Open air inlet doors (TM 9-2350-256-10). Disconnect wire 48 pin A from bulkhead to master relay wiring harness. Place red multimeter lead in socket and black lead to ground. Turn MASTER switch on and check for voltage. If voltage is present, repair/replace switch panel, radio, and bilge pump to bulkhead wiring harness (see WP 0202 00). If voltage is not present, troubleshoot master relay circuit (see WP 0042 00).

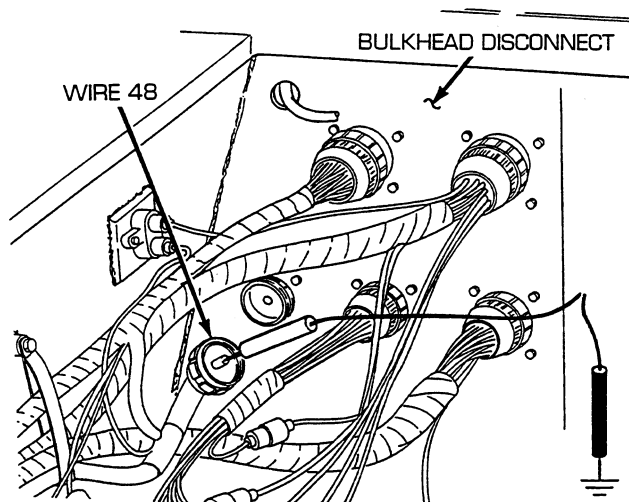

CORRECTIVE ACTION –Continued

- Remove four nuts (6), four lockwashers (7), and four screws (8) and release APU control box (9) from mounting bracket. Place a jumper wire from pin N to socket N. Place red lead of multimeter on pin K of wire 420A and black lead to ground. Turn MASTER and APU FUEL SHUTOFF switches ON, and check for voltage. Turn MASTER and APU FUEL SHUTOFF switches OFF. If voltage is present, go to step 12. If voltage is not present, go to step 6.

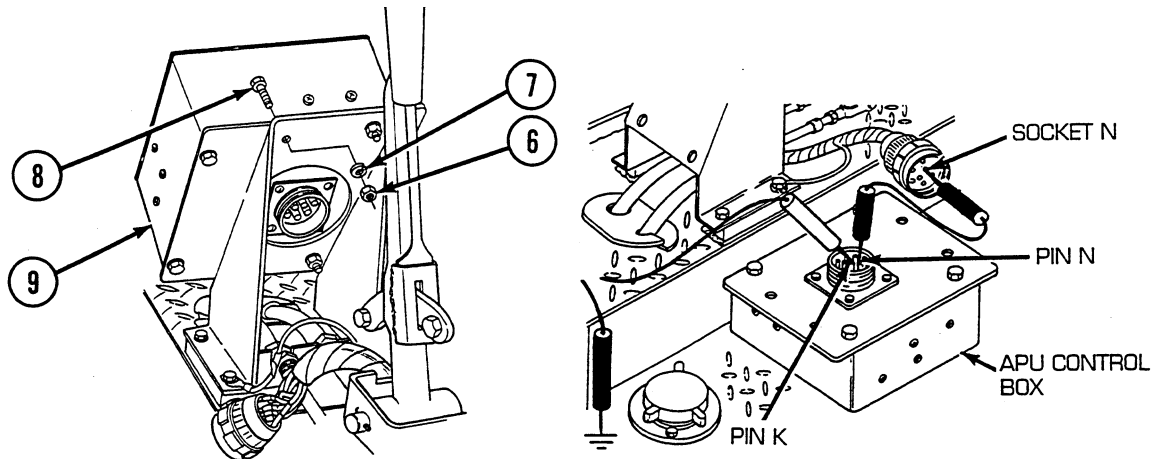

- Reconnect APU control box to foot dimmer switch and bulkhead wiring harness to APU control box. Remove four screws (10), four lockwashers (11), and release rear panel (12) from APU control box. Disconnect wire 419 from panel connector side of 15 A circuit breaker. Place red lead of multimeter in wire 419 and black lead to ground. Turn MASTER switch on and check for voltage. Turn MASTER switch OFF. If voltage is present, go to step 7. If voltage is not present, repair/replace wire 419 of APU control box wiring harness (see WP 0438 00).

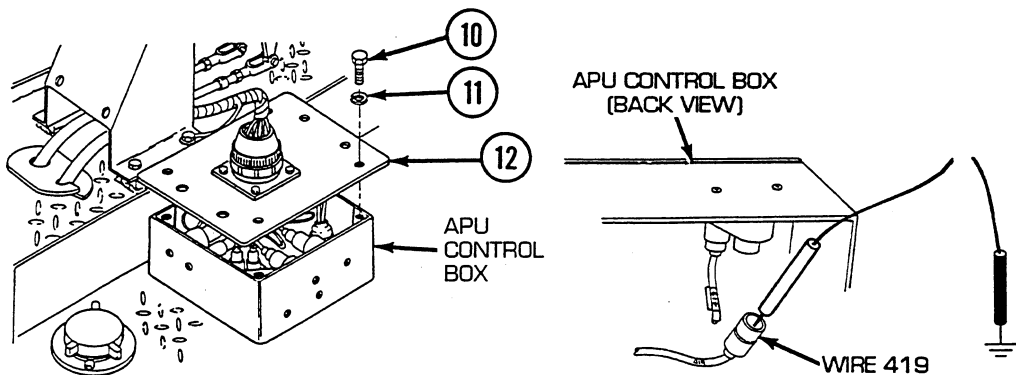

CORRECTIVE ACTION –Continued

7. Reconnect wire 419 to panel connector side of 15 A circuit breaker. Disconnect wire 419 from APU FUEL SHUTOFF switch side of 15 A circuit breaker. Place red lead of multimeter on terminal of circuit breaker and black lead to ground. Turn MASTER switch on and check for voltage. Turn MASTER switch OFF. If voltage is present, go to step 8. If voltage is not present, replace 15 A circuit breaker (see WP 0438 00).

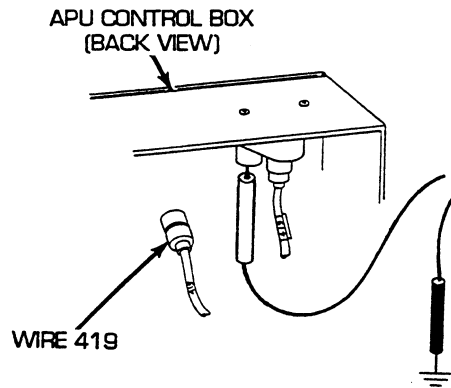

8. Reconnect wire 419 to APU FUEL SHUTOFF switch side of 15 A circuit breaker. Disconnect wire 419 from circuit breaker side of APU FUEL SHUTOFF switch. Place red lead of multimeter in wire 419 and black lead to ground. Turn MASTER switch on and check for voltage. Turn MASTER switch OFF. If voltage is present, go to step 9. If voltage is not present, repair/replace wire 419 of APU fuel shutoff lead assembly (see WP 0438 00).

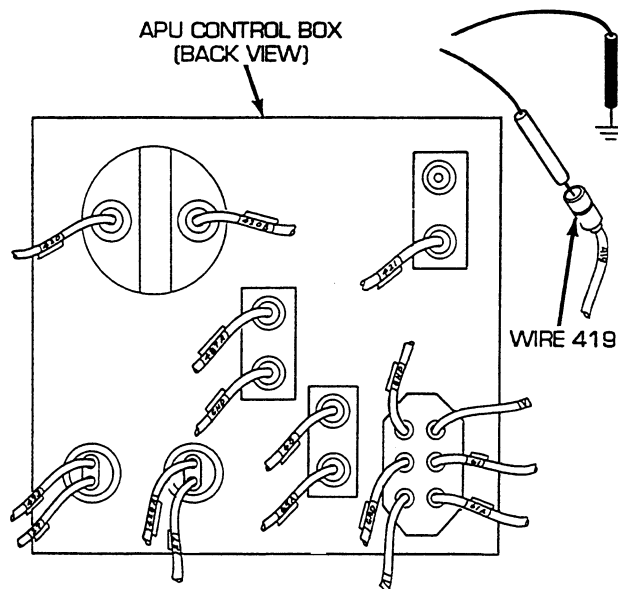

CORRECTIVE ACTION –Continued

9. Reconnect wire 419 to circuit breaker side of APU FUEL SHUTOFF switch. Disconnect wire 421 from APU FUEL SHUTOFF switch. Place red lead of multimeter on terminal of APU FUEL SHUTOFF switch and black lead to ground. Turn MASTER and APU FUEL SHUTOFF switches ON and check for voltage. Turn MASTER and APU FUEL SHUTOFF switches OFF. If voltage is present, go to step 10. If voltage is not present, replace APU FUEL SHUTOFF switch (see WP 0438 00).

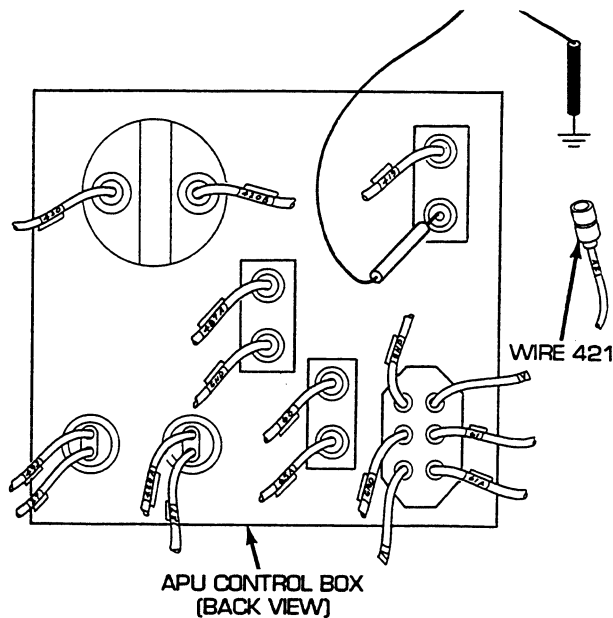

10. Reconnect wire 421 to APU FUEL SHUTOFF switch. Disconnect connector from LOW OIL PRESS lamp. Place red lead of multimeter in wire 27 and black lead to ground. Turn MASTER and APU FUEL SHUTOFF switches ON and check for voltage. Turn MASTER and APU FUEL SHUTOFF switches OFF. If voltage is present, go to step 11. If voltage is not present, repair/replace wire 421/27 of APU control box wiring harness (see WP 0438 00).

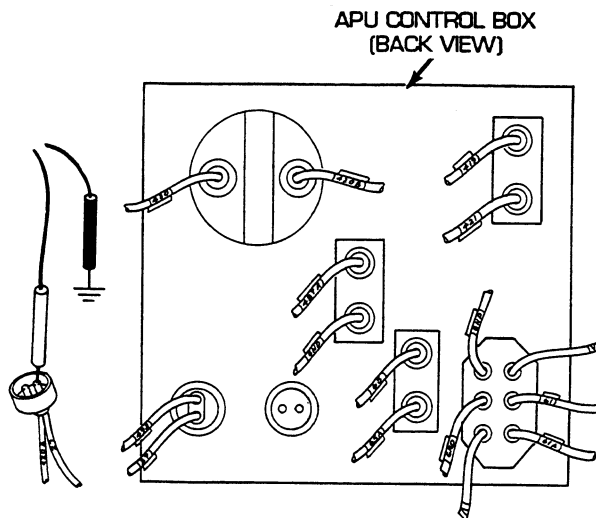

CORRECTIVE ACTION –Continued

11. Place a jumper wire from wire 27 to terminal of LOW OIL PRESS lamp. Place red lead of multimeter on terminal of lamp and black lead to ground. Turn MASTER and APU FUEL SHUTOFF switches on and check for voltage. Turn MASTER and APU FUEL SHUTOFF switches OFF. If voltage is present, repair/replace wire 420A of APU control box wiring harness (see WP 0438 00). If voltage is not present, replace lamp socket (see WP 0438 00).

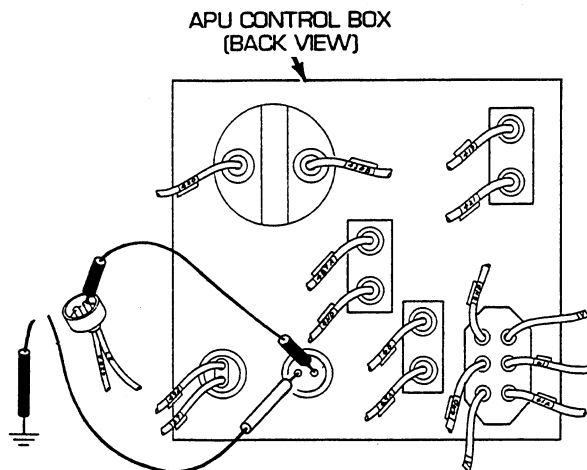

12. Install APU control box (9), four screws (8), four lockwashers (7), and four nuts (6) to mounting bracket. Reconnect APU control box to foot dimmer switch and bulkhead wiring harness to APU control box. Disconnect bulkhead to APU, master relay, and rigger's lights wiring harness from bulkhead disconnect. Place red lead of multimeter on pin C of wire 420A and black lead to ground. Turn MASTER and APU FUEL SHUTOFF switches ON and check for voltage. Turn MASTER and APU FUEL SHUTOFF switches OFF. If voltage is present, go to step 13. If voltage is not present, repair/replace wire 420A of APU control box to foot dimmer switch and bulkhead wiring harness (see WP 0228 00 for dual voltage; 0229 00 for single voltage).

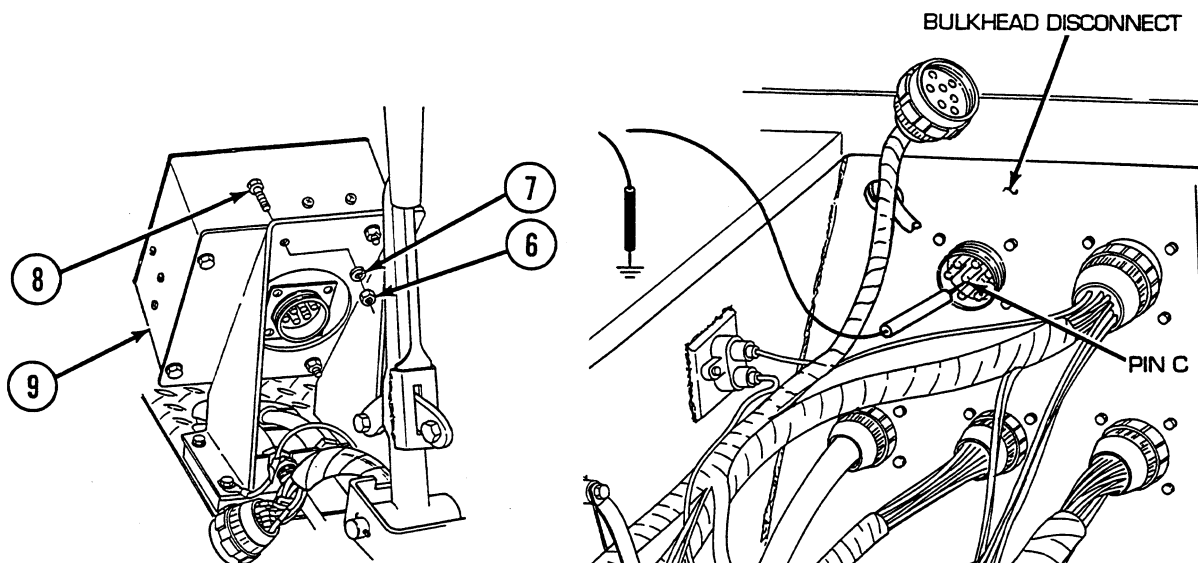

CORRECTIVE ACTION –Continued

13. Reconnect bulkhead to APU, master relay, and rigger's lights wiring harness to bulkhead disconnect. Open center-front air inlet doors (TM 9-2350-256-10). Disconnect bulkhead to APU, master relay, and rigger's lights wiring harness from APU engine disconnect. Place red lead of multimeter on pin B of wire 420A and black lead to ground. Turn MASTER and APU FUEL SHUTOFF switches ON and check for voltage. Turn MASTER and APU FUEL SHUTOFF switches OFF. If voltage is present, notify Direct Support Maintenance. If voltage is not present, repair/replace wire 420A of bulkhead to APU, master relay, and rigger's lights wiring harness (see WP 0224 00 for dual voltage; 0225 00 for single voltage).

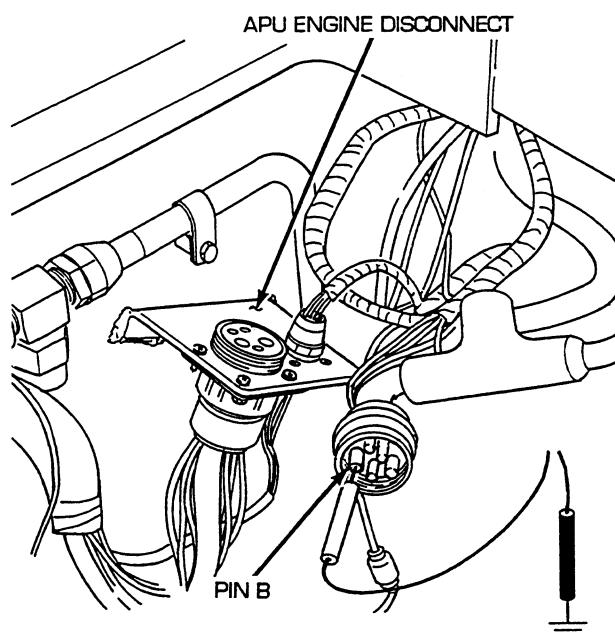
**END OF WORK PACKAGE**

UNIT MAINTENANCE
RECOVERY VEHICLE, FULL TRACKED: MEDIUM, M88A1
NSN 2350-00-122-6826, EIC AQA

APU HIGH AIR TEMPERATURE SYSTEM TROUBLESHOOTING PROCEDURE

INITIAL SETUP:**Tools and Special Tools**

Tool kit, general mechanic's (item 59, WP 0490 00)

References

WP 0042 00

WP 0202 00

WP 0224 00

References (cont.)

WP 0225 00

WP 0228 00

WP 0229 00

WP 0438 00

TM 9-2350-256-10

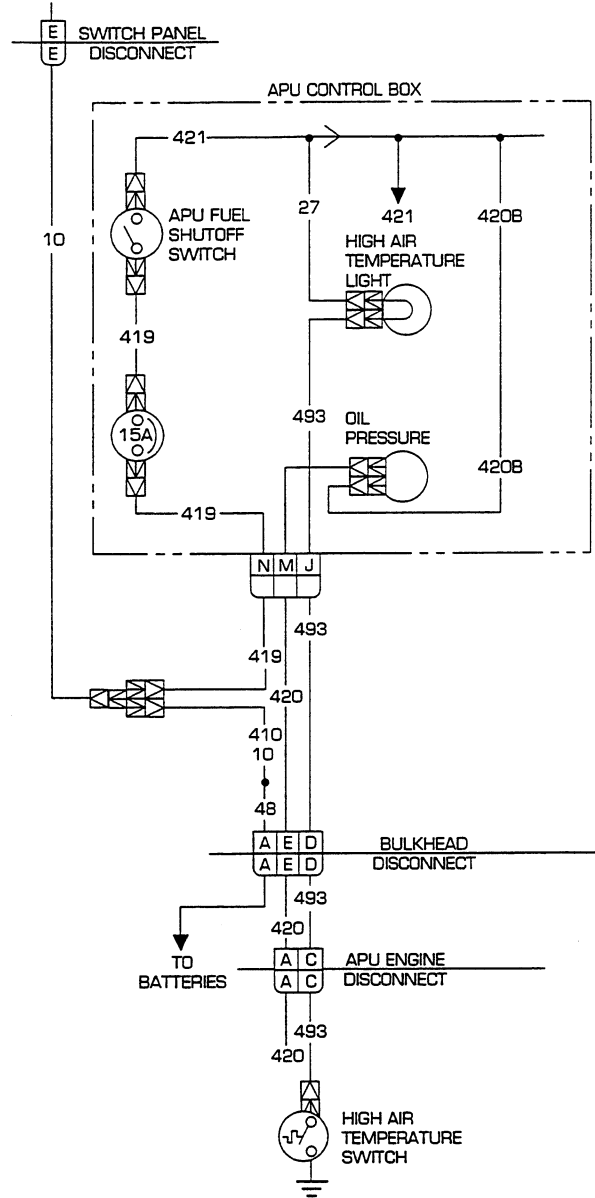
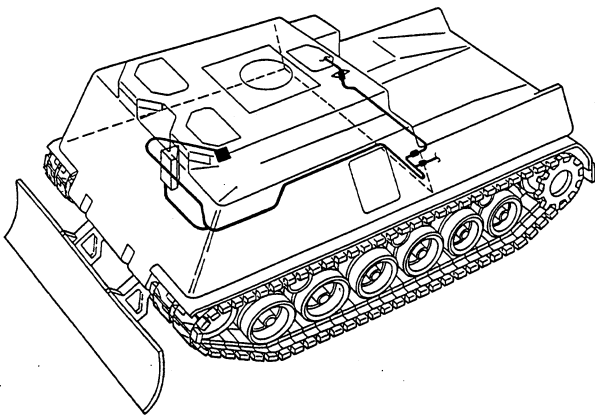

Troubleshooting Procedure**APU High Air Temperature System****Symptom**

APU high air temperature system malfunctioning.

Malfunction

APU high air temperature lamp does not light when air temperature is high. Do steps 1 thru 13.

CORRECTIVE ACTION**WARNING**

Remove all jewelry such as rings, dog tags, bracelets, etc. If jewelry contacts a metal surface a direct short may result in instant heating of tools, damage to equipment, and injury or death to personnel.

1. Remove lamp from socket. Place red lead of multimeter in socket and black lead to ground. Turn MASTER and APU FUEL SHUTOFF switches ON, and check for voltage. Turn MASTER and APU FUEL SHUTOFF switches OFF. If voltage is present, replace lamp (see WP 0438 00). If voltage is not present, go to step 2.

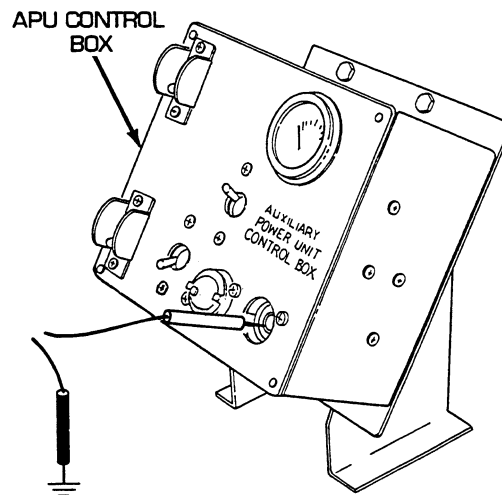

CORRECTIVE ACTION –Continued

2. Disconnect APU control box to foot dimmer switch and bulkhead wiring harness from APU control box. Place red lead of multimeter in socket N of wire 419 and black lead to ground. Turn MASTER switch on and check for voltage. Turn MASTER switch OFF. If voltage is present, go to step 5. If voltage is not present, go to step 3.

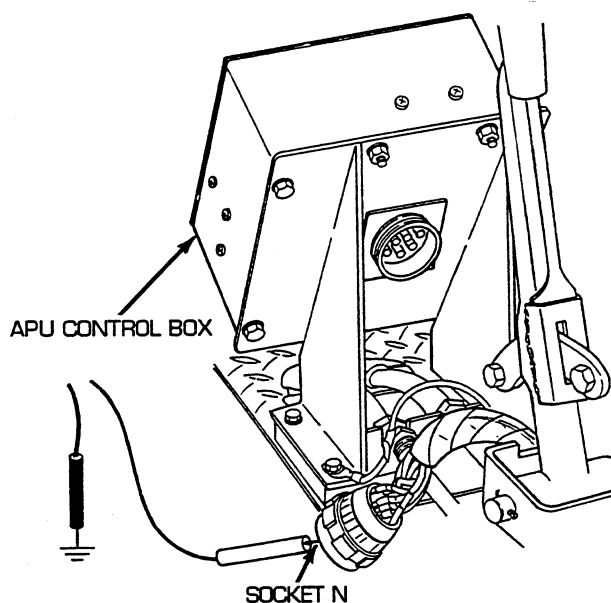

3. Reconnect APU control box to foot dimmer switch and bulkhead wiring harness to APU control box. Remove three screws (1), three lockwashers (2), ground wire (3), and flat washer (4) and release main switch panel (5) from mounting bracket. Disconnect wire 10-419 from Y-connector of switch panel, radio, and bilge pump to bulkhead wiring harness at main switch panel. Turn MASTER switch on, and check for voltage. If voltage is present, repair wire 419 from Y-connector at main switch panel to APU control box bulkhead wiring harness. If voltage is not present, go to step 4.

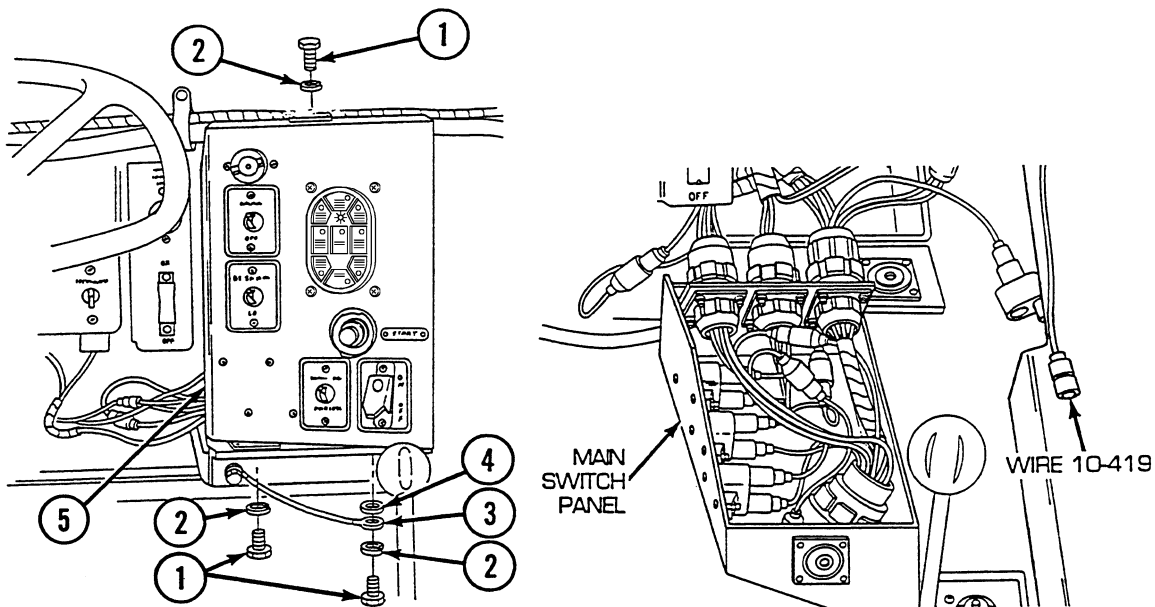

CORRECTIVE ACTION –Continued

4. Reconnect wire 10-419 to Y-connector of switch panel, radio, and bilge pump to bulkhead wiring harness to main switch panel. Install main switch panel (5), flat washer (4), ground wire (3), three lockwashers (2), and three screws (1) to mounting bracket. Open air inlet doors (TM 9-2350-256-10). Disconnect wire 48 pin A from bulkhead to master relay wiring harness. Place red multimeter lead in socket and black lead to ground. Turn MASTER switch on and check for voltage. If voltage is present, repair/replace switch panel, radio, and bilge pump to bulkhead wiring harness (see WP 0202 00). If voltage is not present, troubleshoot master relay circuit (see WP 0042 00).

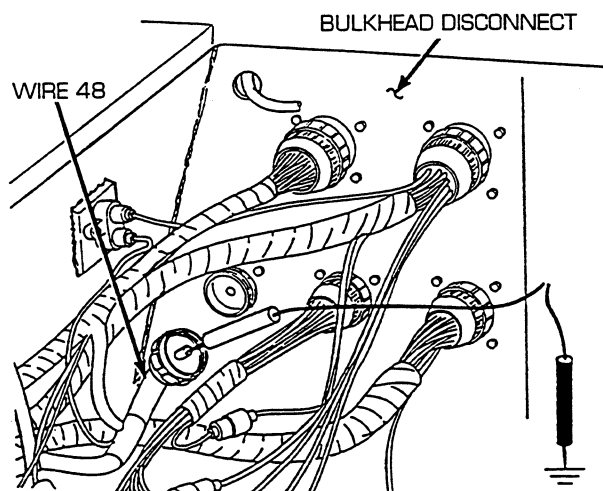

5. Remove four nuts (6), four lockwashers (7), and four screws (8), and release APU control box (9) from mounting bracket. Place a jumper wire from pin N to socket N. Place red lead of multimeter on pin J of wire 493 and black lead to ground. Turn MASTER APU FUEL SHUTOFF switches ON, and check for voltage. Turn MASTER and APU FUEL SHUTOFF switches OFF. If voltage is present, go to step 12. If voltage is not present, go to step 6.

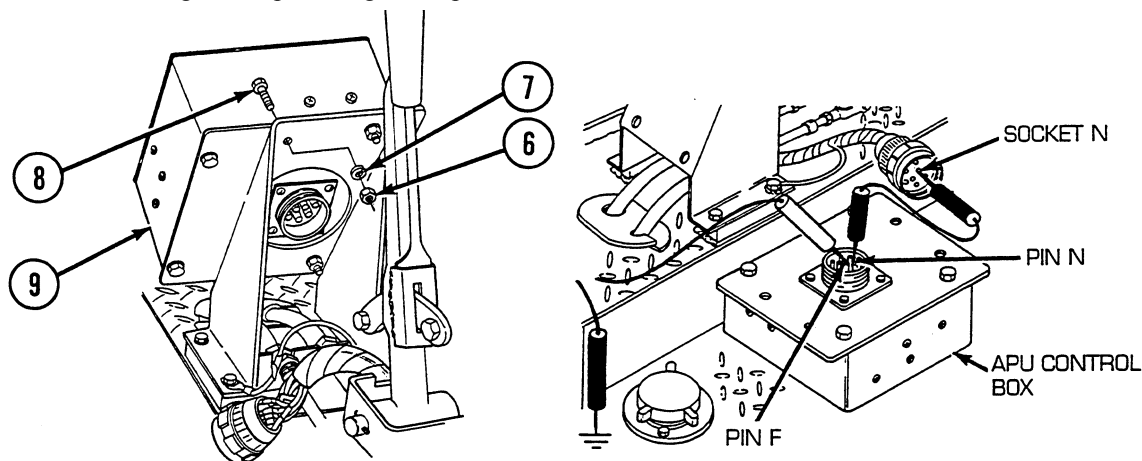

CORRECTIVE ACTION –Continued

6. Reconnect APU control box to foot dimmer switch and bulkhead wiring harness to APU control box. Remove four screws (10), four lockwashers (11), and pull rear panel (12) from APU control box (9). Disconnect wire 419 from panel connector side of 15 A circuit breaker. Place red lead of multimeter in wire 419 and black lead to ground. Turn MASTER switch on, and check for voltage. Turn MASTER switch OFF. If voltage is present, go to step 7. If voltage is not present, repair/replace wire 419 of APU control box wiring harness (see WP 0438 00).

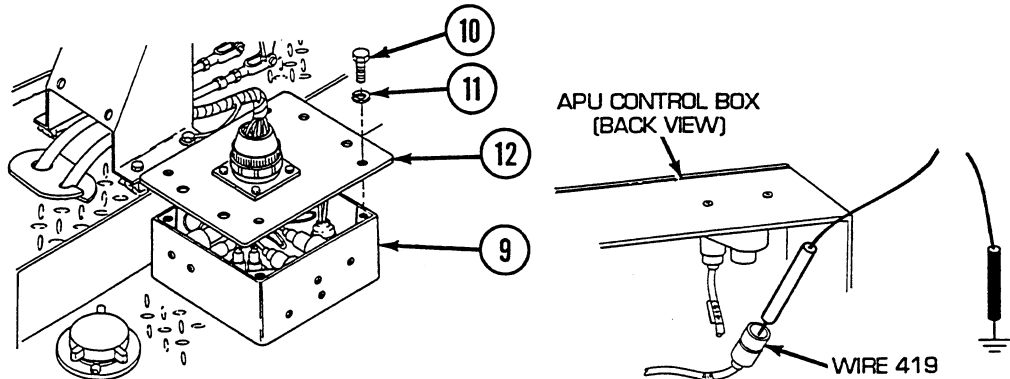

7. Reconnect wire 419 to panel connector side of 15 A circuit breaker. Disconnect wire 419 from APU FUEL SHUTOFF switch side of 15 A circuit breaker. Place red lead of multimeter on terminal of circuit breaker and black lead to ground. Turn MASTER switch on and check for voltage. Turn MASTER switch OFF. If voltage is present, go to step 8. If voltage is not present, replace 15 A circuit breaker (see WP 0438 00).

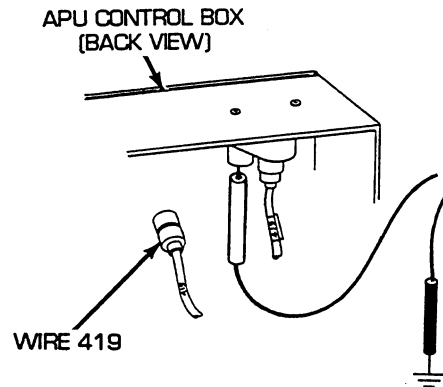

CORRECTIVE ACTION –Continued

8. Reconnect wire 419 to APU FUEL SHUTOFF switch side of 15 A circuit breaker. Disconnect wire 419 from circuit breaker side of APU FUEL SHUTOFF switch. Place red lead of multimeter in wire 419 and black lead to ground. Turn MASTER switch on and check for voltage. Turn MASTER switch OFF. If voltage is present, go to step 9. If voltage is not present, repair/replace wire 419 of APU control box wiring harness (see WP 0438 00).

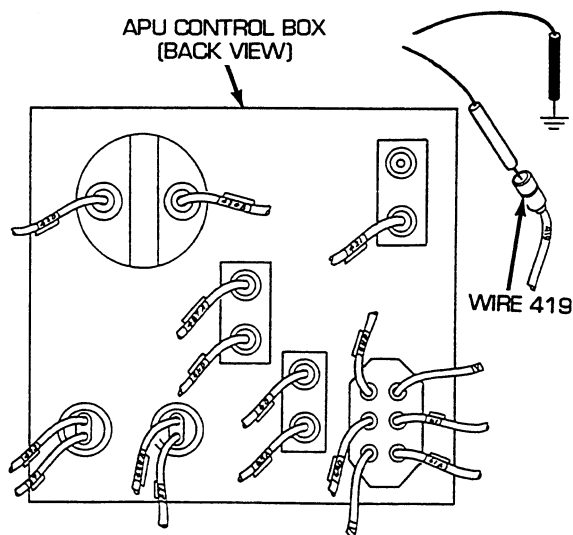

9. Reconnect wire 419 to circuit breaker side of APU FUEL SHUTOFF switch. Disconnect wire 421 from APU FUEL SHUTOFF switch. Place red lead of multimeter in terminal of APU FUEL SHUTOFF switch and black lead to ground. Turn MASTER and APU FUEL SHUTOFF switches ON and check for voltage. Turn MASTER and APU FUEL SHUTOFF switches OFF. If voltage is present, go to step 10. If voltage is not present, replace APU FUEL SHUTOFF switch (see WP 0438 00).

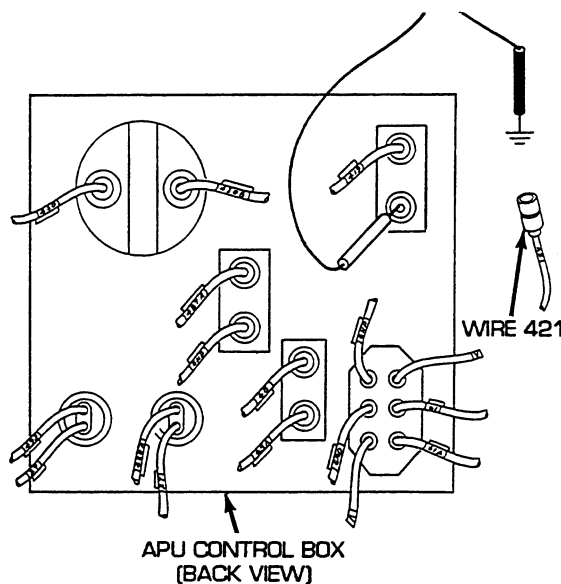

CORRECTIVE ACTION –Continued

10. Reconnect wire 421 to APU FUEL SHUTOFF switch. Disconnect connector from HIGH AIR TEMP lamp. Place red lead of multimeter on wire 27 and black lead to ground. Turn MASTER and APU FUEL SHUTOFF switches ON and check for voltage. Turn MASTER and APU FUEL SHUTOFF switches OFF. If voltage is present, go to step 11. If voltage is not present, repair/replace wire 421/27 of APU control box wiring harness (see WP 0438 00).

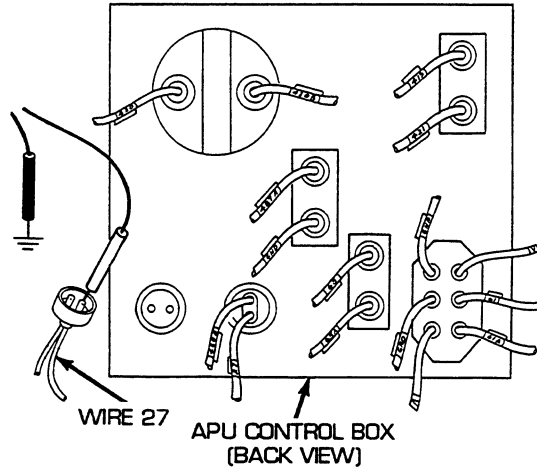

11. Place a jumper wire from wire 27 to terminal of HIGH AIR TEMP lamp. Place red lead of multimeter on terminal of lamp and black lead to ground. Turn MASTER and APU FUEL SHUTOFF switches ON and check for voltage. Turn MASTER and APU FUEL SHUTOFF switches OFF. If voltage is present, repair/replace wire 493 of APU control box wiring harness (see WP 0438 00). If voltage is not present, replace HIGH AIR TEMP lamp (see WP 0438 00).

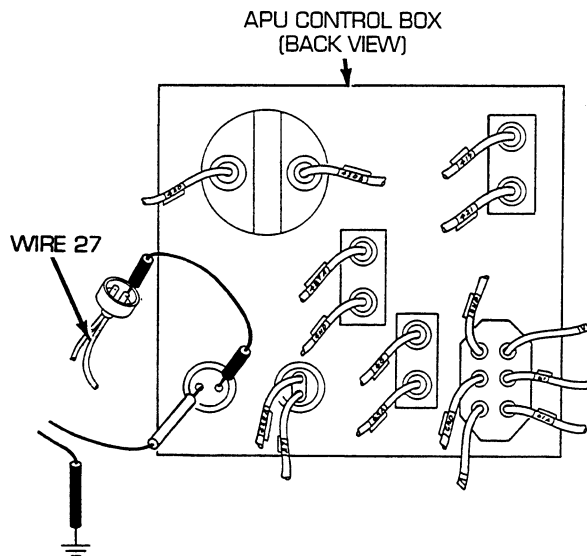

CORRECTIVE ACTION –Continued

12. Reconnect APU control box to foot dimmer switch and bulkhead wiring harness APU control box. Install APU control box (9), four screws (8), four lockwashers (7), and four nuts (6) to mounting bracket. Open air inlet doors. Disconnect bulkhead to APU, master relay, and rigger’s lights wiring harness from bulkhead disconnect. Place red lead of multimeter on pin D of wire 493 and black lead to ground. Turn MASTER and APU FUEL SHUTOFF switches ON and check for voltage. Turn MASTER and APU FUEL SHUTOFF switches OFF. If voltage is present, go to step 13. If voltage is not present, repair/replace wire 493 of APU control box to foot dimmer switch and bulkhead wiring harness (see WP 0228 00 for dual voltage; 0229 00 for single voltage).

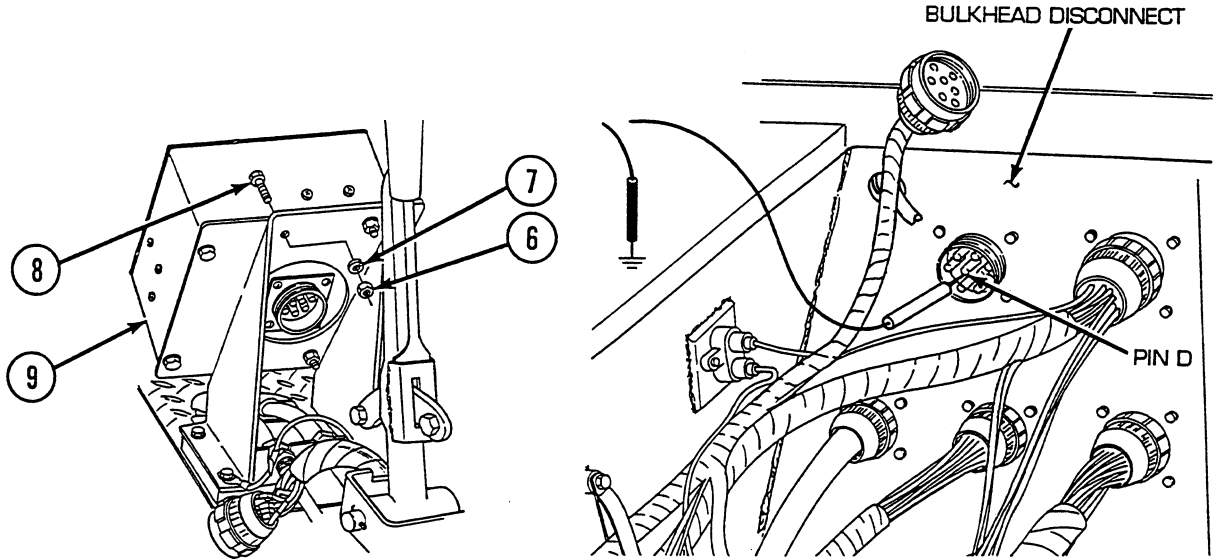

CORRECTIVE ACTION –Continued

13. Reconnect bulkhead to APU, master relay, and rigger's lights wiring harness to bulkhead disconnect. Open center-front air inlet doors (TM 9-2350-256-10). Disconnect bulkhead to APU, master relay, and rigger's lights wiring harness from APU engine disconnect. Place red lead of multimeter on pin C of wire 493 and black lead to ground. Turn MASTER and APU FUEL SHUTOFF switches ON and check for voltage. Turn MASTER and APU FUEL SHUTOFF switches OFF. If voltage is present, notify Direct Support Maintenance. If voltage is not present, repair/replace wire 493 of bulkhead to APU, master relay, and rigger's lights wiring harness (see WP 0224 00 for dual voltage; 0225 00 for single voltage).

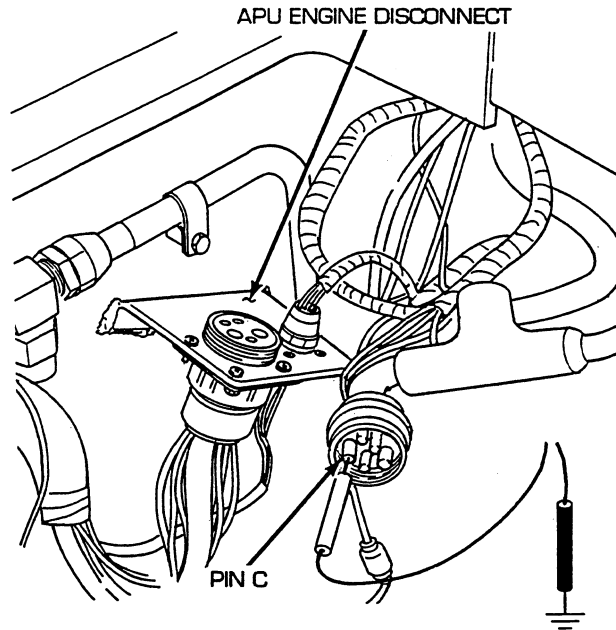
**END OF WORK PACKAGE**

UNIT MAINTENANCE
RECOVERY VEHICLE, FULL TRACKED: MEDIUM, M88A1
NSN 2350-00-122-6826, EIC AQA

APU ENGINE OIL PRESSURE GAGE CIRCUIT TROUBLESHOOTING PROCEDURE

INITIAL SETUP:

Tools and Special Tools

Tool kit, general mechanic's (item 59, WP 0490 00)

References

WP 0042 00

WP 0202 00

WP 0224 00

References (cont.)

WP 0225 00

WP 0228 00

WP 0229 00

WP 0438 00

TM 9-2350-256-10

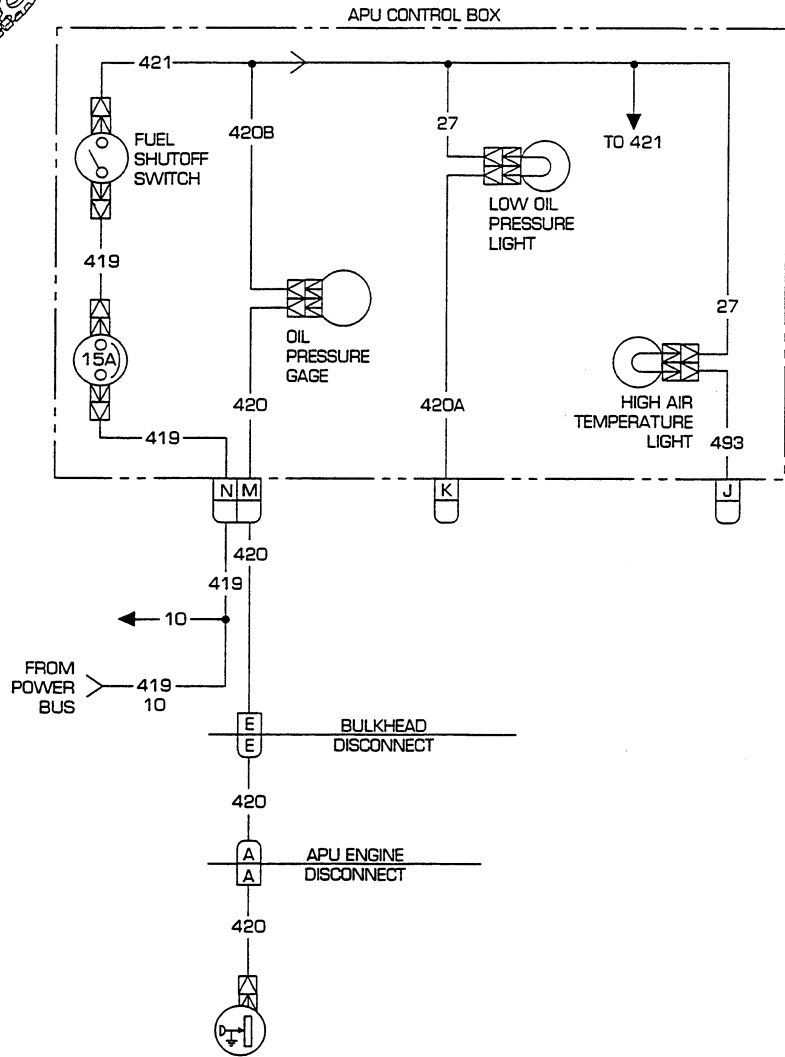
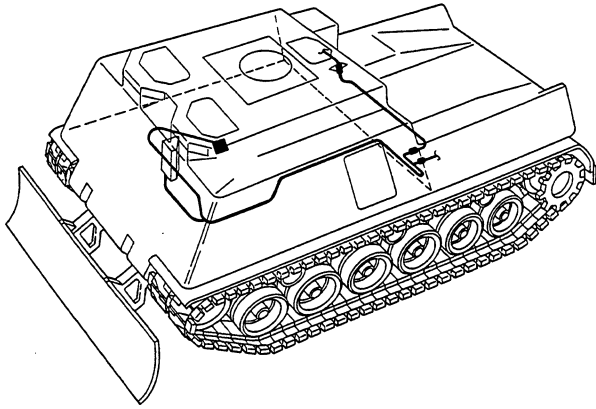

Troubleshooting Procedure

APU Engine Oil Pressure Gage Circuit

Symptom

APU engine oil pressure gage circuit malfunctioning.

Malfunction

APU engine oil pressure gage fails to operate. Do steps 1 thru 12.

CORRECTIVE ACTION

WARNING

Remove all jewelry such as rings, dog tags, bracelets, etc. If jewelry contacts a metal surface a direct short may result in instant heating of tools, damage to equipment, and injury or death to personnel.

1. Disconnect APU control box to foot dimmer switch and bulkhead wiring harness from APU control box. Place red lead of multimeter in socket N, wire 419 and black lead to ground. Turn MASTER switch on and check for voltage. Turn MASTER switch OFF. If voltage is present, go to step 4. If voltage is not present, go to step 2.

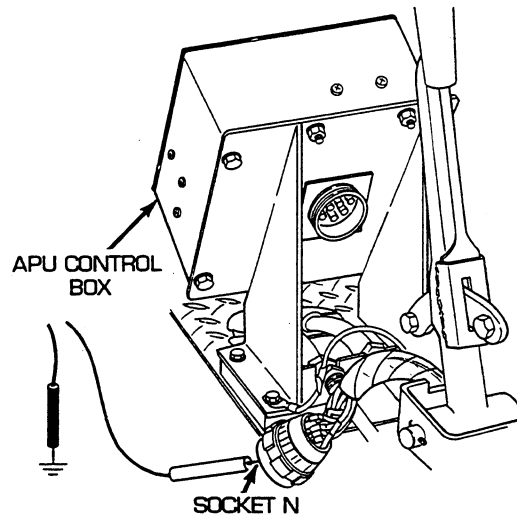

CORRECTIVE ACTION –Continued

2. Reconnect APU control box to foot dimmer switch and bulkhead wiring harness to APU control box. Remove three screws (1), three lockwashers (2), ground wire (3), and flat washer (4) and release main switch panel (5) from mounting bracket. Disconnect wire 10-419 from Y-connector of switch panel, radio, and bilge pump to bulkhead wiring harness at main switch panel. Turn MASTER switch on, and check for voltage. If voltage is present, repair wire 419 from Y-connector at main switch panel to APU control box bulkhead wiring harness. If voltage is not present, go to step 3.

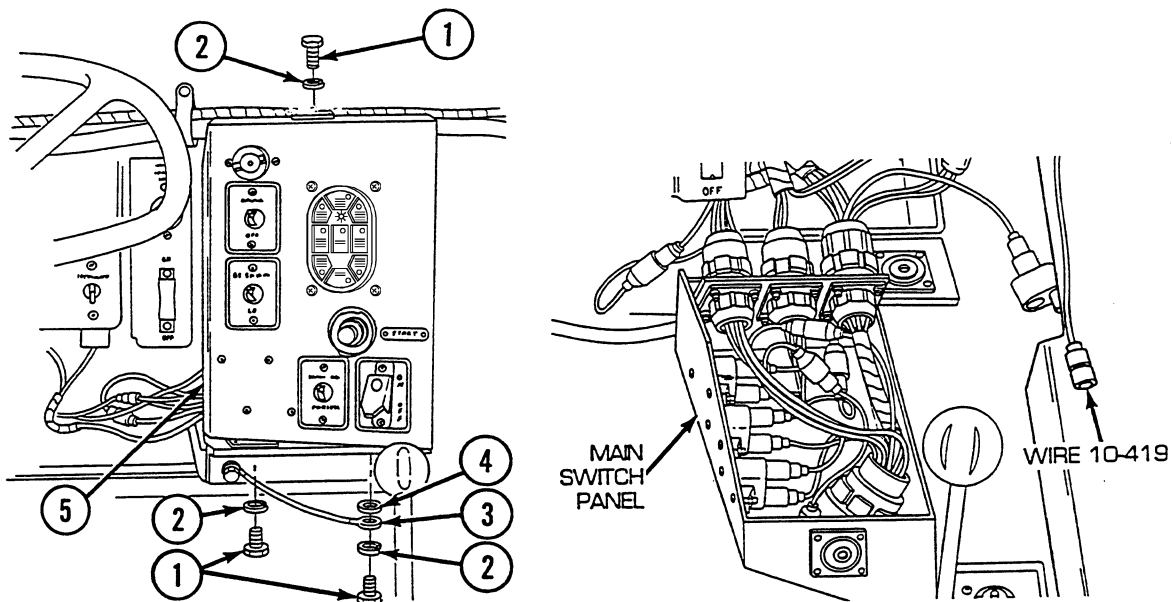

3. Reconnect wire 10-419 to Y-connector of switch panel, radio, and bilge pump to bulkhead wiring harness to main switch panel. Install main switch panel (5), flat washer (4), ground wire (3), three lockwashers (2), and three screws (1) to mounting bracket. Disconnect wire 48 pin A from bulkhead to master relay wiring harness. Place red multimeter lead in socket and black lead to ground. Turn MASTER switch on and check for voltage. If voltage is present, repair/replace switch panel, radio, and bilge pump to bulkhead wiring harness (see WP 0202 00). If voltage is not present, troubleshoot master relay circuit (see WP 0042 00).

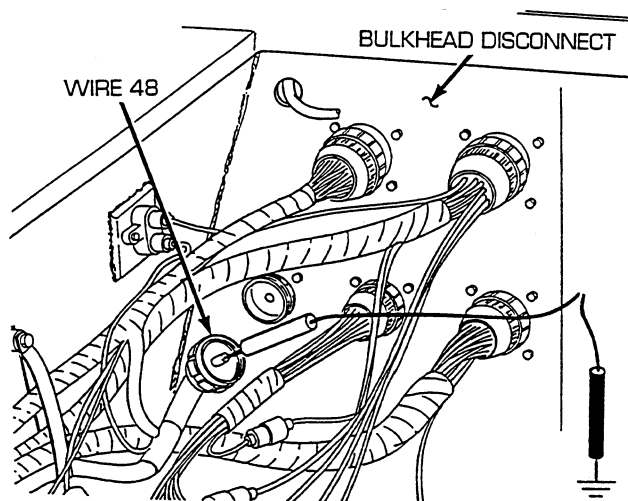

CORRECTIVE ACTION –Continued

4. Remove four nuts (6), four lockwashers (7), and four screws (8), and release APU control box (9) from mounting bracket. Place a jumper wire from pin N to socket N. Place red lead of multimeter on pin M of wire 420 and black lead to ground. Turn MASTER and APU FUEL SHUTOFF switches ON, and check for voltage. Turn MASTER and APU FUEL SHUTOFF switches OFF. If voltage is present, go to step 11. If voltage is not present, go to step 5.

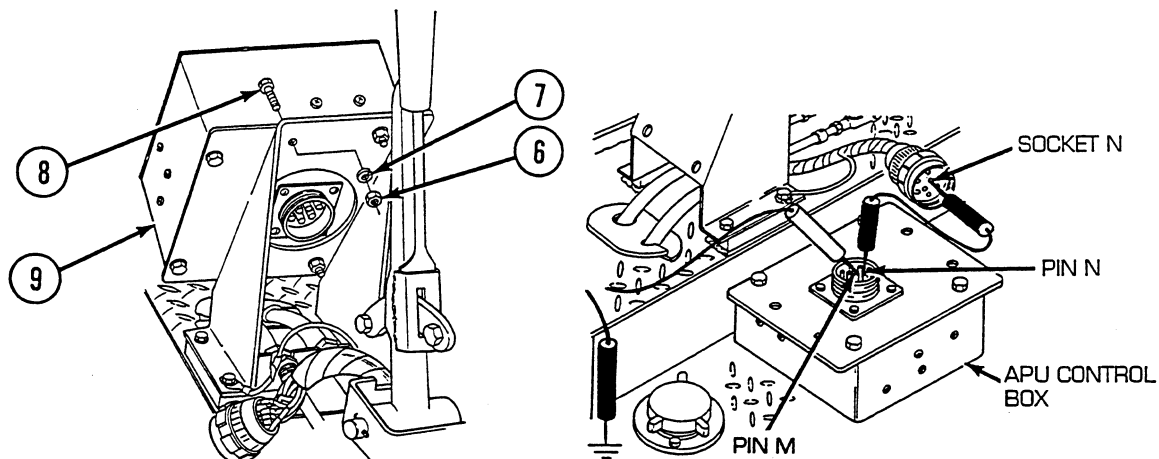

5. Reconnect APU control box to foot dimmer switch and bulkhead wiring harness to APU control box. Remove four nuts (10) and four lockwashers (11), and pull rear panel (12) from APU control box (9). Disconnect wire 419 from panel connector side 15 A circuit breaker. Place red lead of multimeter in wire 419 and black lead to ground. Turn MASTER switch on and check for voltage. Turn MASTER switch OFF. If voltage is present, go to step 6. If voltage is not present, repair/replace wire 419 of APU control box wiring harness (see WP 0438 00).

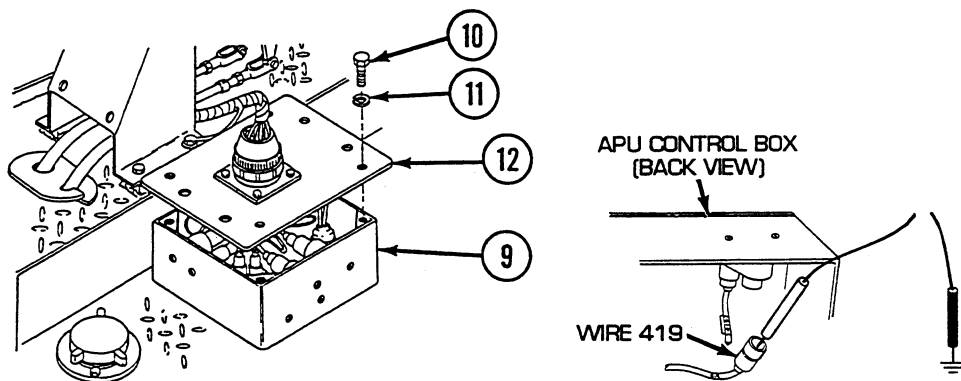

CORRECTIVE ACTION –Continued

6. Reconnect wire 419 to panel connector side of 15 A circuit breaker. Disconnect wire 419 from APU FUEL SHUTOFF switch side of 15 A circuit breaker. Place red lead of multimeter on terminal of circuit breaker and black lead to ground. Turn MASTER switch on and check for voltage. Turn MASTER switch OFF. If voltage is present, go to step 7. If voltage is not present, replace 15 A circuit breaker (see WP 0438 00).

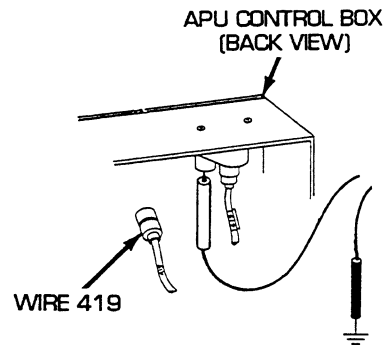

7. Reconnect wire 419 to 15 A circuit breaker. Disconnect wire 419 from circuit breaker side of APU FUEL SHUTOFF switch. Place red lead of multimeter in wire 419 and black lead to ground. Turn MASTER switch on and check for voltage. Turn MASTER switch OFF. If voltage is present, go to step 8. If voltage is not present, repair/replace wire 419 of APU fuel shutoff lead assembly (see WP 0438 00).

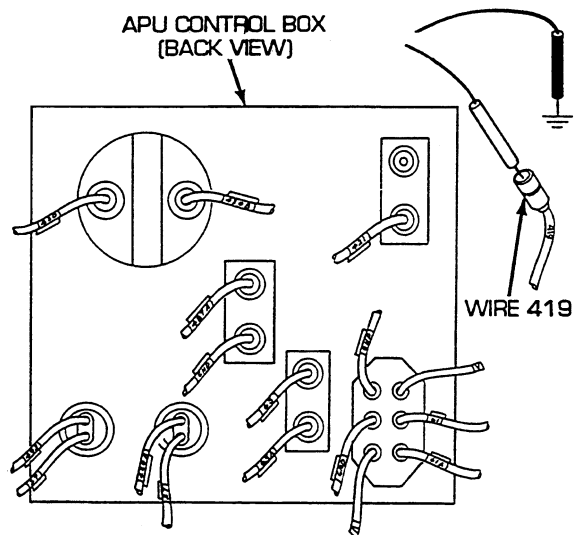

CORRECTIVE ACTION –Continued

8. Reconnect wire 419 to circuit breaker side of APU FUEL SHUTOFF switch. Disconnect wire 421 from APU FUEL SHUTOFF switch. Place red lead of multimeter on terminal of APU FUEL SHUTOFF switch and black lead to ground. Turn MASTER and APU FUEL SHUTOFF switches ON and check for voltage. Turn MASTER and APU FUEL SHUTOFF switches OFF. If voltage is present, go to step 9. If voltage is not present, replace APU FUEL SHUTOFF switch (see WP 0438 00).

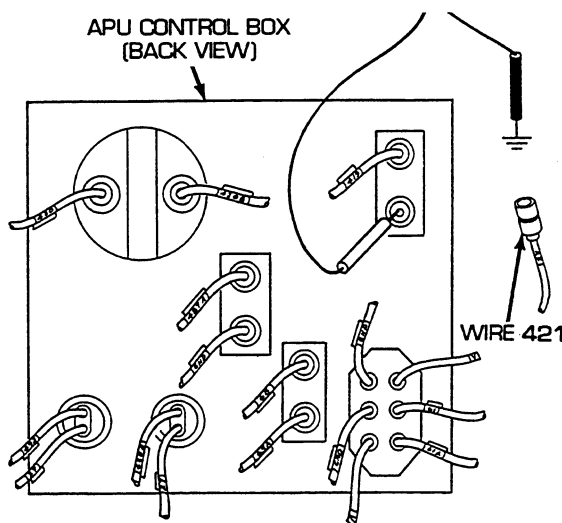

9. Reconnect wire 421 to APU FUEL SHUTOFF switch. Disconnect wire 420B from ENGINE OIL PRESSURE gage. Place red lead of multimeter in wire 420B and black lead to ground. Turn MASTER and APU FUEL SHUTOFF switches ON and check for voltage. Turn MASTER and APU FUEL SHUTOFF switches OFF. If voltage is present, go to step 10. If voltage is not present, repair/replace wire 421/420B of APU control box wiring harness (see WP 0438 00).

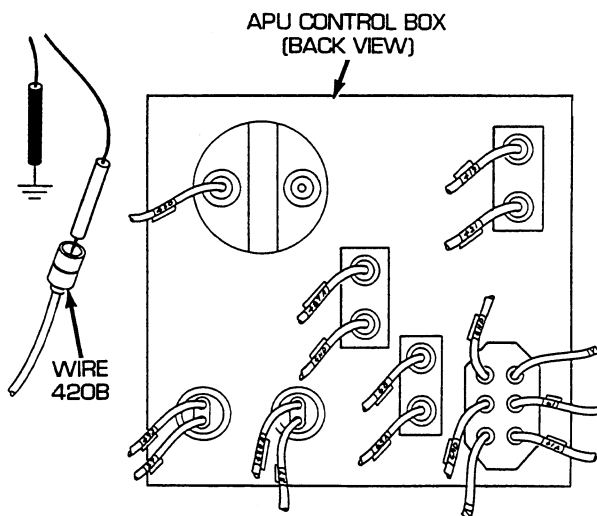

CORRECTIVE ACTION –Continued

10. Reconnect wire 420B to ENGINE OIL PRESSURE gage. Disconnect wire 420 from ENGINE OIL PRESSURE gage. Place red lead of multimeter on terminal of gage and black lead to ground. Turn MASTER and APU FUEL SHUTOFF switches ON and check for voltage. Turn MASTER and APU FUEL SHUTOFF switches OFF. If voltage is present, repair/replace wire 420 of APU control box wiring harness (see WP 0438 00). If voltage is not present, replace ENGINE OIL PRESSURE gage (see WP 0438 00).

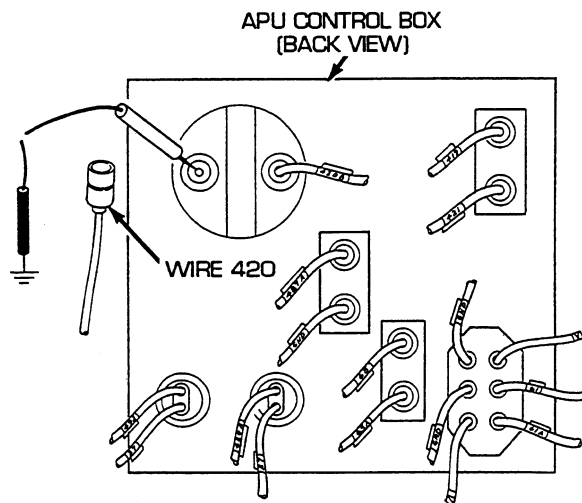

11. Install APU control box (9), four screws (8), four lockwashers (7), and four nuts (6) to mounting bracket. Open air inlet doors (TM 9-2350-256-10). Reconnect APU control box to foot dimmer switch and bulkhead wiring harness to APU control box. Disconnect bulkhead to APU, master relay, and riggers' lights wiring harness from bulkhead disconnect. Place red lead of multimeter on pin E and black lead to ground. Turn MASTER and APU FUEL SHUTOFF switches ON and check for voltage. Turn MASTER and APU FUEL SHUTOFF switches OFF. If voltage is present, go to step 12. If voltage is not present, repair/replace wire 420 of APU control box to foot dimmer switch and bulkhead wiring harness (see WP 0228 00 for dual voltage; 0229 00 for single voltage).

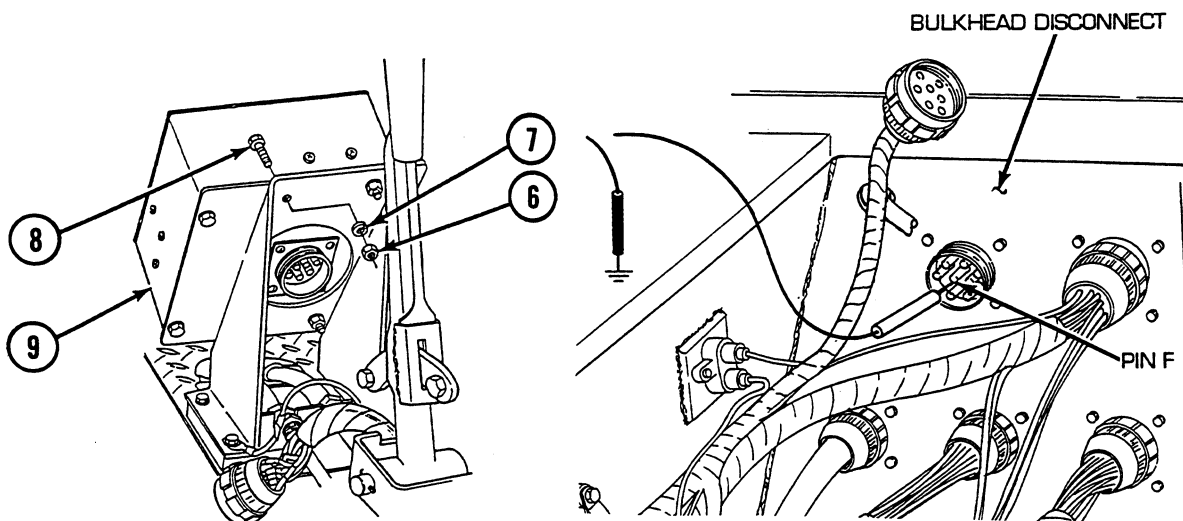

CORRECTIVE ACTION –Continued

12. Reconnect bulkhead to APU, master relay, and rigger's lights wiring harness to bulkhead disconnect. Open center-front air inlet doors (TM 9-2350-256-10). Disconnect bulkhead to APU, master relay, and rigger's lights wiring harness from APU engine disconnect. Place red lead of multimeter on pin A of wire 420 and black lead to ground. Turn MASTER and APU FUEL SHUTOFF switches ON and check for voltage. Turn MASTER and APU FUEL SHUTOFF switches OFF. If voltage is present, notify Direct Support Maintenance. If voltage is not present, repair/replace wire 420 of bulkhead to APU, master relay, and rigger's lights wiring harness (see WP 0224 00 for dual voltage; 0225 00 for single voltage).

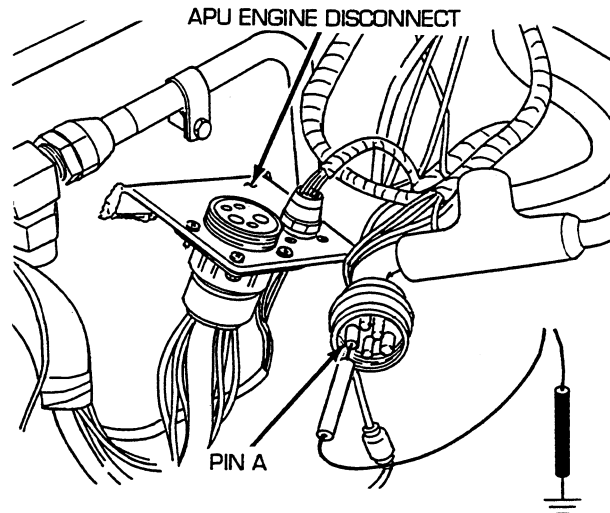
**END OF WORK PACKAGE**

UNIT MAINTENANCE
RECOVERY VEHICLE, FULL TRACKED: MEDIUM, M88A1
NSN 2350-00-122-6826, EIC AQA

MECHANICAL TRANSMISSION OIL PRESSURE LIGHT TROUBLESHOOTING PROCEDURE

INITIAL SETUP:**Tools and Special Tools**

Tool kit, general mechanic's (item 59, WP 0490 00)

References

WP 0042 00
WP 0157 00
WP 0159 00
WP 0167 00
WP 0193 00

References (cont.)

WP 0194 00
WP 0195 00
WP 0202 00
WP 0204 00
WP 0205 00
WP 0218 00
TM 9-2350-256-10

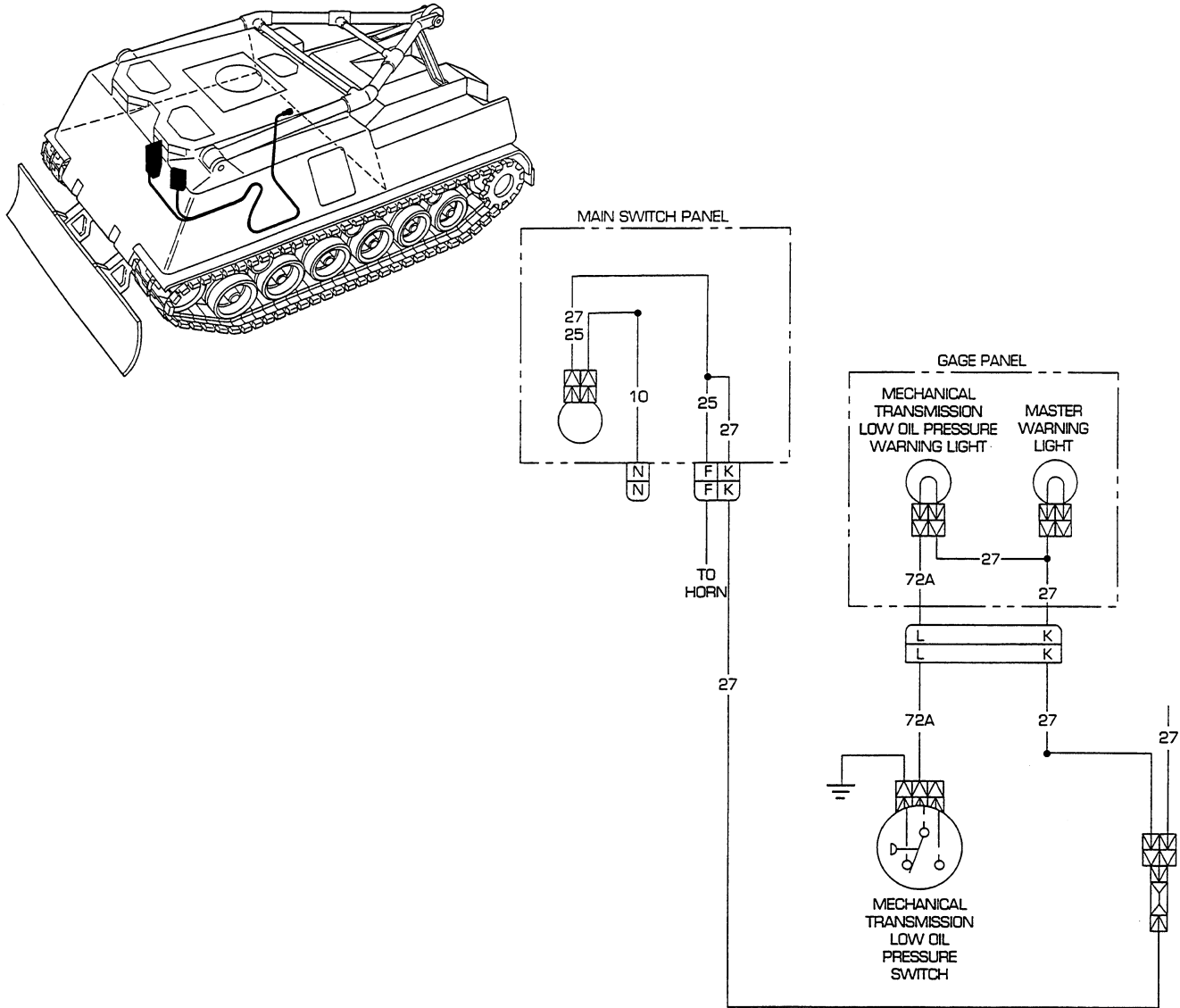

Troubleshooting Procedure

Mechanical Transmission Oil Pressure Light

Symptom

Mechanical transmission oil pressure light malfunctioning.

Malfunction

Mechanical transmission oil pressure warning light does not go out with mechanical transmission operating. Do steps 1 thru 13.

Mechanical transmission oil pressure warning light fails to operate with mechanical transmission stopped. Do steps 4 thru 13.

CORRECTIVE ACTION**WARNING**

Remove all jewelry such as rings, dog tags, bracelets, etc. If jewelry contacts a metal surface a direct short may result in instant heating of tools, damage to equipment, and injury or death to personnel.

1. Remove three screws (1), three lockwashers (2), two screws (3), two lockwashers (4), and ground strap (5), and release gage panel (6) from mounting brackets. Disconnect connector from MECH TRANSMISSION OIL PRESSURE light. Place red lead of multimeter in wire 27E and black lead to ground. Turn MASTER switch on, and check for voltage. Turn MASTER switch OFF. If voltage is present, go to step 11. If voltage is not present, go to step 2.

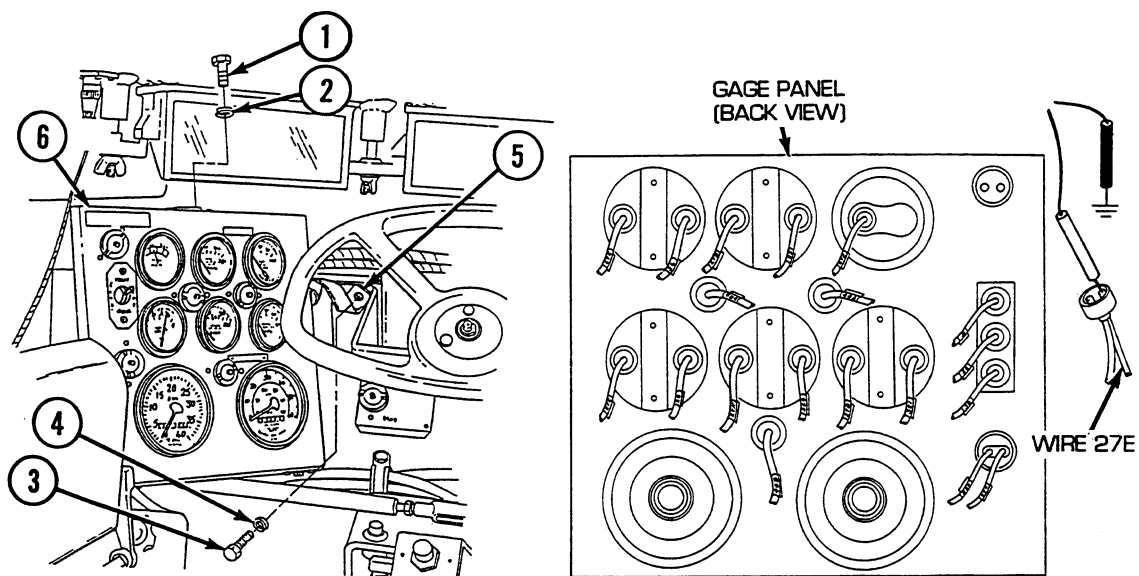

CORRECTIVE ACTION –Continued

2. Reconnect connector to MECH TRANSMISSION OIL PRESSURE light. Disconnect gage panel to bulkhead wiring harness from gage panel. Place red lead of multimeter in socket K of wire 27 and black lead to ground. Turn MASTER switch on and check for voltage. Turn MASTER switch OFF. If voltage is present, repair/replace wire 27/27K of gage panel wiring harness (see WP 0193 00). If voltage is not present, go to step 3.

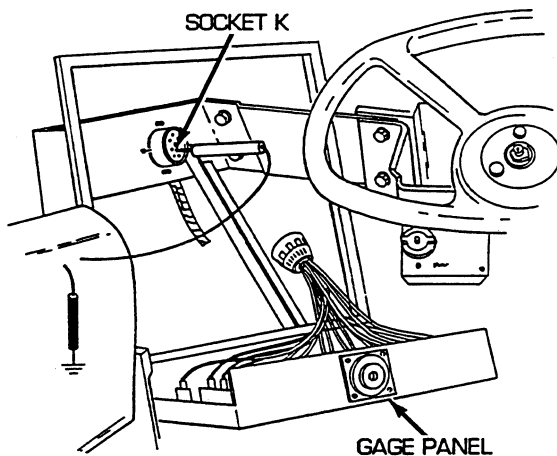

3. Reconnect gage panel to bulkhead wiring harness to gage panel. Install ground strap (5), two lockwashers (4), two screws (3), gage panel (6), three lockwashers (2), and three screws (1) to mounting brackets. Remove three screws (7), three lockwashers (8), ground lead (9), and flat washer (10), and release main switch panel (11) from mounting brackets. Disconnect switch panel to gage panel and miscellaneous switches wiring harness from switch panel. Place red lead of multimeter in pin N and black lead to ground. Turn MASTER switch on and check for voltage. Turn MASTER switch OFF. If voltage is present, go to step 5. If voltage is not present, go to step 4.

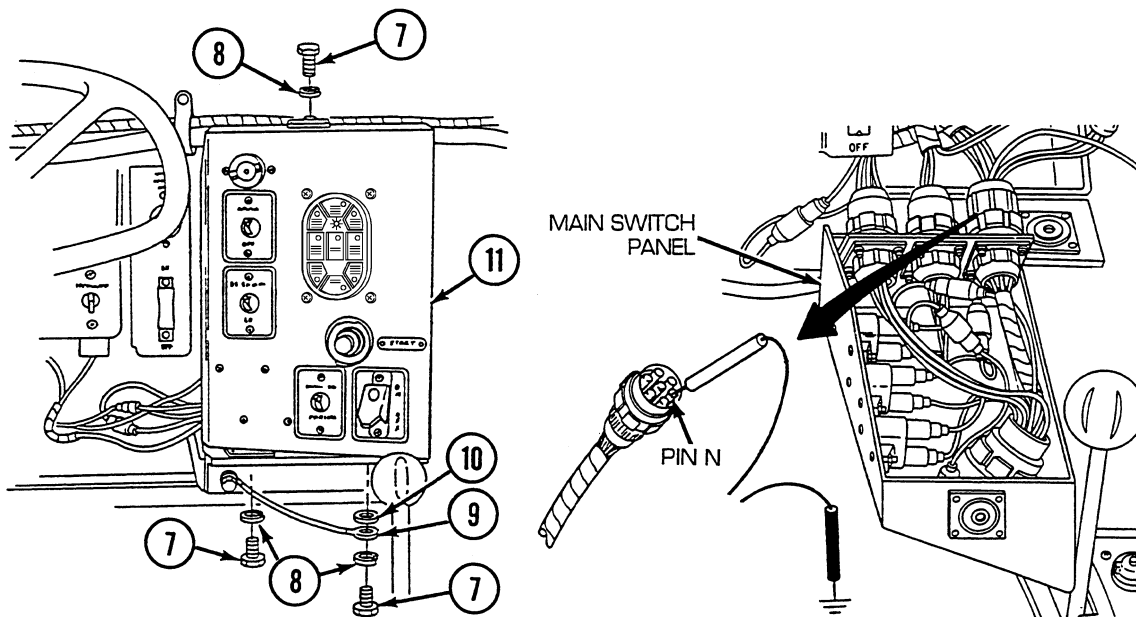

CORRECTIVE ACTION –Continued

4. Reconnect switch panel to gage panel and miscellaneous switches wiring harness to switch panel. Install main switch panel (11), flat washer (10), ground lead (9), three lockwashers (8), and three screws (7) to mounting brackets. Open air inlet doors (TM 9-2350-256-10). Disconnect switch panel, radio, and bilge pump to bulkhead wiring harness from bulkhead disconnect. Place red lead of multimeter in socket A wire 48 and black lead to ground. Turn MASTER switch on and check for voltage. Turn MASTER switch OFF. If voltage is present, repair/replace switch panel, radio, and bilge pump to bulkhead wiring harness (see WP 0202 00). If voltage is not present, troubleshoot master relay (see WP 0042 00).

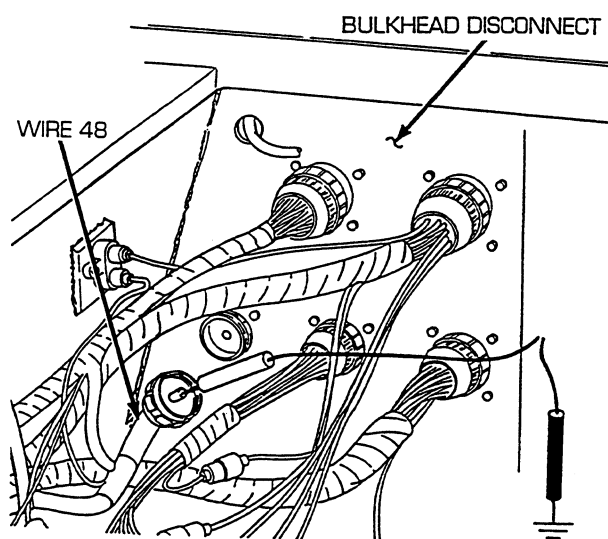

5. Place jumper wire from socket N to pin N. Place red lead of multimeter in socket K of switch panel and black lead to ground. Turn MASTER switch on and check for voltage. Turn MASTER switch OFF. If voltage is present, go to step 6. If voltage is not present, go to step 8.

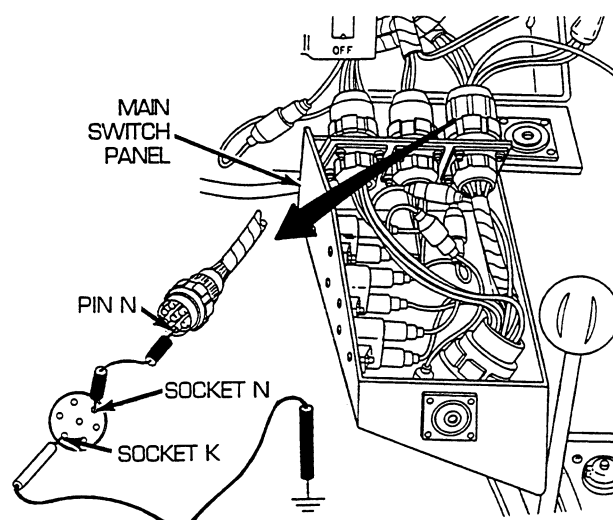

CORRECTIVE ACTION –Continued

6. Reconnect switch panel to gage panel and miscellaneous switches wiring harness to switch panel. Disconnect wire 27 from Y-connector. Place red multimeter lead on wire 27 and black lead to ground. Turn MASTER switch on and check for voltage. Turn MASTER switch OFF. If voltage is present, go to step 7. If voltage is not present, repair/replace wire 27 of switch panel to gage panel and miscellaneous switches wiring harness (see WP 0204 00 for dual voltage; 0205 00 for single voltage).

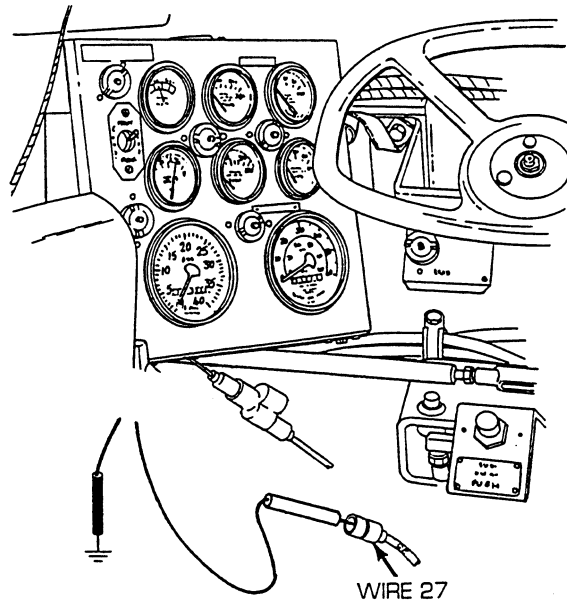

CORRECTIVE ACTION –Continued

7. Reconnect wire 27 at Y-connector. Install main switch panel (11), flat washer (10), ground lead (9), three lockwashers (8), and three screws (7) to mounting brackets. Remove three screws (1), three lockwashers (2), two screws (3), two lockwashers (4), and ground strap (5) and release gage panel (6) from mounting brackets.

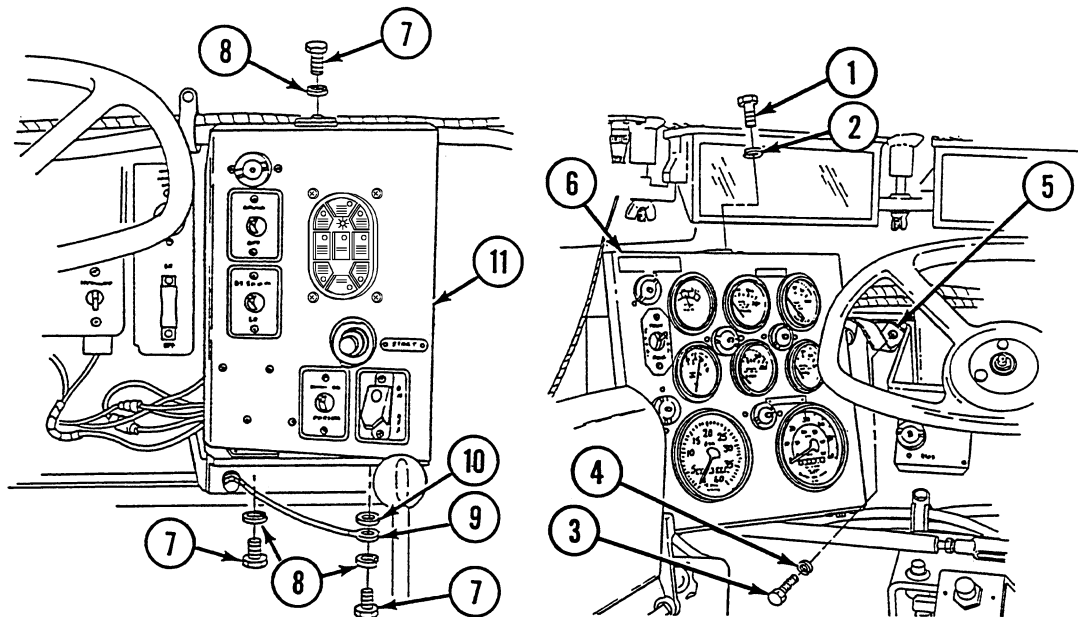

Disconnect switch panel to gage panel and miscellaneous switches wiring harness from gage panel. Place red multimeter on socket K and black lead to ground. Turn MASTER switch on and check for voltage. Turn MASTER switch OFF. If voltage is present, go to step 12. If voltage is not present, repair/replace wire 27 of switch panel to gage panel and miscellaneous switches wiring harness (see WP 0204 00 for dual voltage; 0205 00 for single voltage).

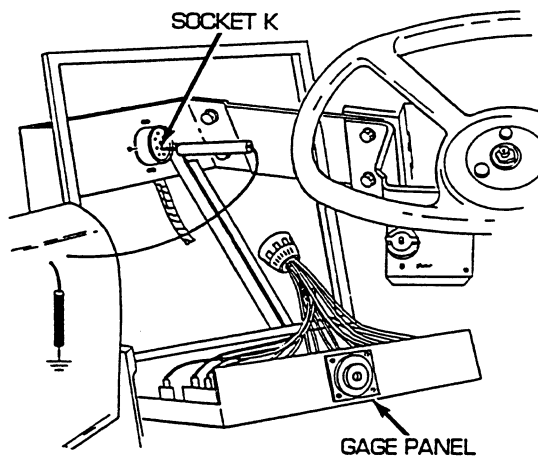

CORRECTIVE ACTION –Continued

8. Reconnect switch panel to gage panel and miscellaneous switches wiring harness to switch panel. Disconnect wire 10 from 15 A circuit breaker. Place red lead of multimeter on wire 10 and black lead to ground. Turn MASTER switch ON and check for voltage. Turn MASTER switch OFF. If voltage is present, go to step 9. If voltage is not present, repair/replace wire 10 of switch panel to gage panel and miscellaneous switches wiring harness (see WP 0204 00 for dual voltage; 0205 00 for single voltage).

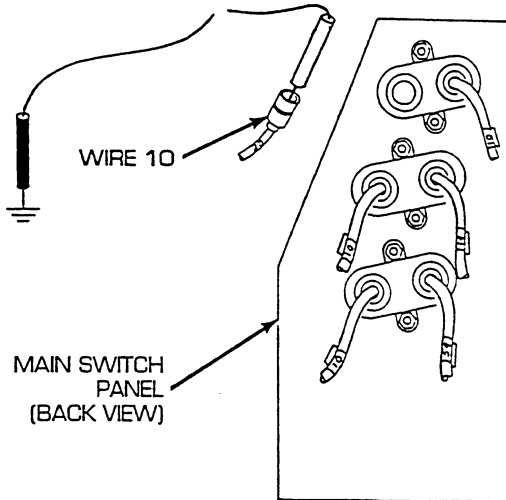

9. Reconnect wire 10 to 15 A circuit breaker. Disconnect wire 25/27 from 15 A circuit breaker. Place red lead of multimeter on terminal of circuit breaker and black lead to ground. Turn MASTER switch on and check for voltage. Turn MASTER switch OFF. If voltage is not present, replace 15 A circuit breaker (see WP 0159 00). If voltage is present, go to step 10.

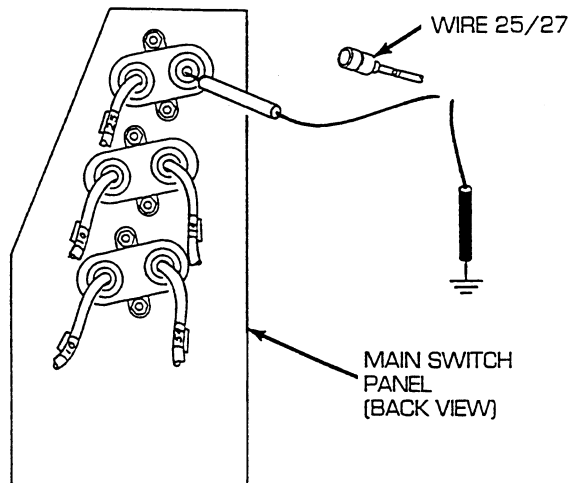

CORRECTIVE ACTION –Continued

10. Reconnect wire 25/27 to 15 A circuit breaker. Disconnect main lighting and B.O. selector switch wiring harness. Place red lead of multimeter on pin K of wire 25/27 and black lead to ground. Turn MASTER switch on and check for voltage. Turn MASTER switch OFF. If voltage is not present, repair/replace wire 25/27 of main lighting and B.O. selector switch wiring harness (see WP 0218 00). If voltage is present, go to step 11.

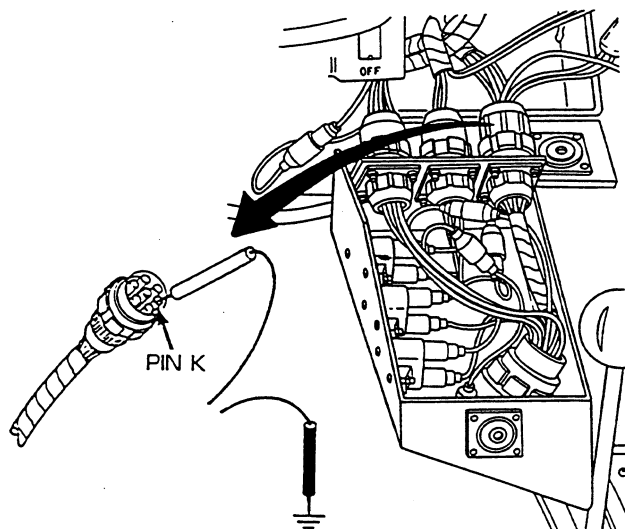

11. Place jumper wire from wire 27K to terminal of MECH TRANSMISSION OIL PRESSURE light. Place red lead of multimeter on terminal of light and black lead to ground. Turn MASTER switch on and check for voltage. Turn MASTER switch OFF. If voltage is present, go to step 12. If voltage is not present, replace MECH TRANSMISSION OIL PRESSURE light (see WP 0157 00).

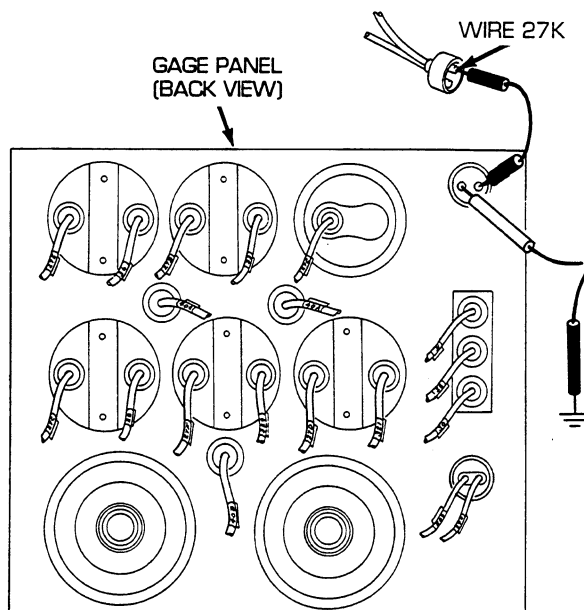

CORRECTIVE ACTION –Continued

12. Reconnect connector to MECH TRANSMISSION OIL PRESSURE light. Disconnect gage panel to bulkhead wiring harness from gage panel. Place a jumper wire from pin K to socket K. Place red lead of multimeter on pin L of wire 72A and black lead to ground. Turn MASTER switch on, and check for voltage. Turn MASTER switch OFF. If voltage is present, go to step 13. If voltage is not present, repair/replace wire 72A of gage panel wiring harness (see WP 0193 00).

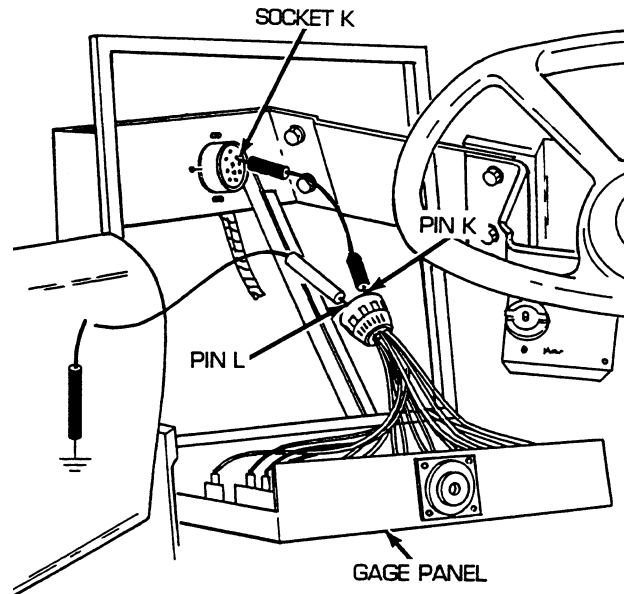

13. Reconnect gage panel to bulkhead wiring harness to gage panel. Disconnect gage panel to bulkhead wiring harness from mechanical transmission low oil pressure switch. Place red lead of multimeter in wire 72A and black lead to ground. Turn MASTER switch on, and check for voltage. Turn MASTER switch OFF. If voltage is present, replace mechanical transmission low oil pressure switch (see WP 0167 00). If light continues to remain lit, with the mechanical transmission operating, the mechanical transmission has low oil pressure. If voltage is not present, repair/replace wire 72A of gage panel to bulkhead wiring harness (see WP 0194 00 for dual voltage; 0195 00 for single voltage).

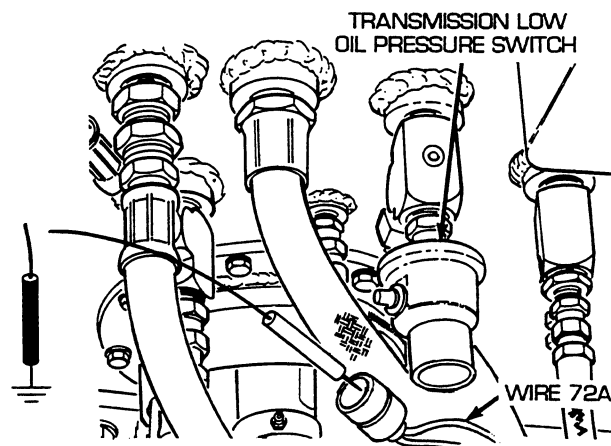

END OF WORK PACKAGE

UNIT MAINTENANCE
RECOVERY VEHICLE, FULL TRACKED: MEDIUM, M88A1
NSN 2350-00-122-6826, EIC AQA
MASTER WARNING LIGHT TROUBLESHOOTING PROCEDURE

INITIAL SETUP:**Tools and Special Tools**

Tool kit, general mechanic's (item 59, WP 0490 00)

References

WP 0042 00
WP 0098 00
WP 0099 00
WP 0157 00
WP 0159 00
WP 0168 00
WP 0171 00
WP 0193 00
WP 0194 00

References (cont.)

WP 0195 00
WP 0202 00
WP 0204 00
WP 0205 00
WP 0207 00
WP 0208 00
WP 0218 00
WP 0222 00
WP 0223 00
WP 0336 00
TM 9-2350-256-10

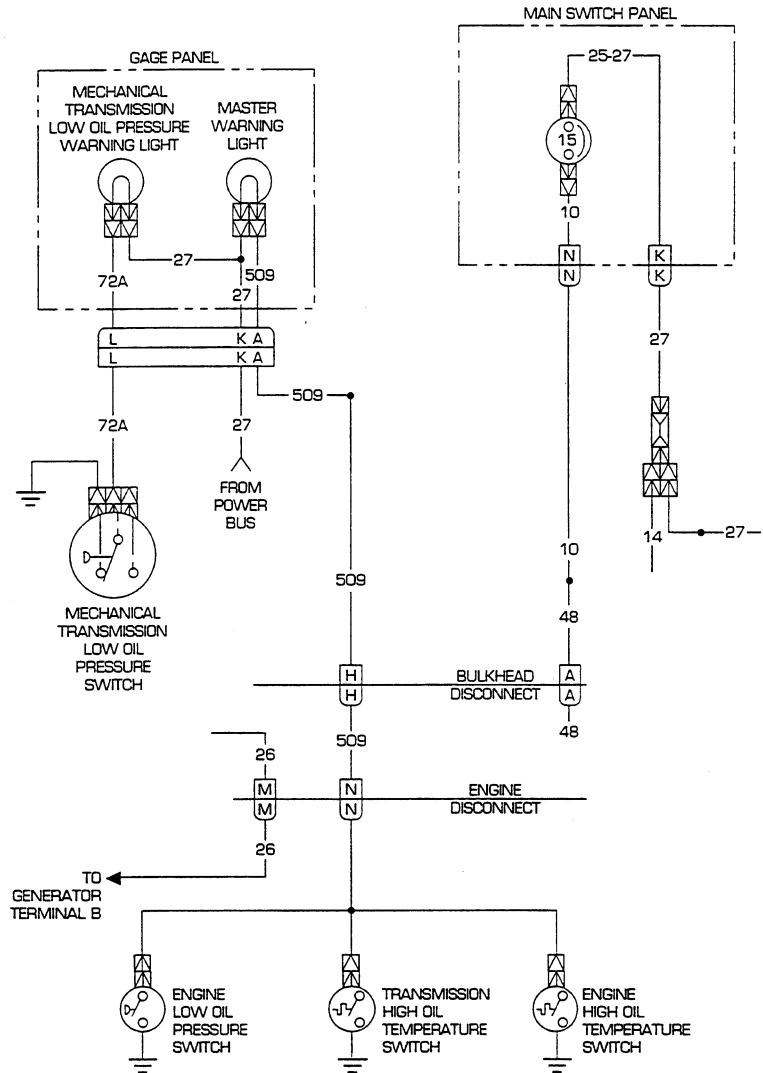
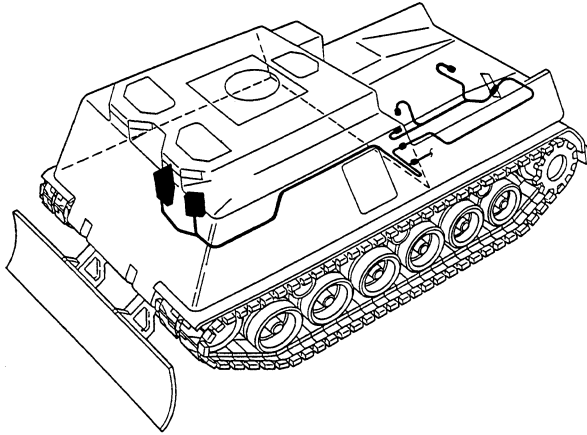

Troubleshooting Procedure

Master Warning Light

Symptom

Master warning light malfunctioning.

Malfunction

Master warning light fails to operate with engine off. Do steps 1 thru 12.

Master warning light does not go out after starting engine. Do step 8 thru 12.

Master warning light does not light with high transmission oil temp, but lights with engine off. Do step 16.

Master warning light does not light with high engine oil temp, but lights with engine off. Do step 17.

CORRECTIVE ACTION

WARNING

Remove all jewelry such as rings, dog tags, bracelets, etc. If jewelry contacts a metal surface a direct short may result in instant heating of tools, damage to equipment, and injury or death to personnel.

1. Remove three screws (1), three lockwashers (2), two screws (3), two lockwashers (4), and ground strap (5) and release gage panel (6) from mounting bracket. Disconnect connector from master warning light. Place red lead of multimeter in wire 27G and black lead to ground. Turn MASTER switch on, and check for voltage. Turn MASTER switch OFF. If voltage is present, go to step 9. If voltage is not present, go to step 2.

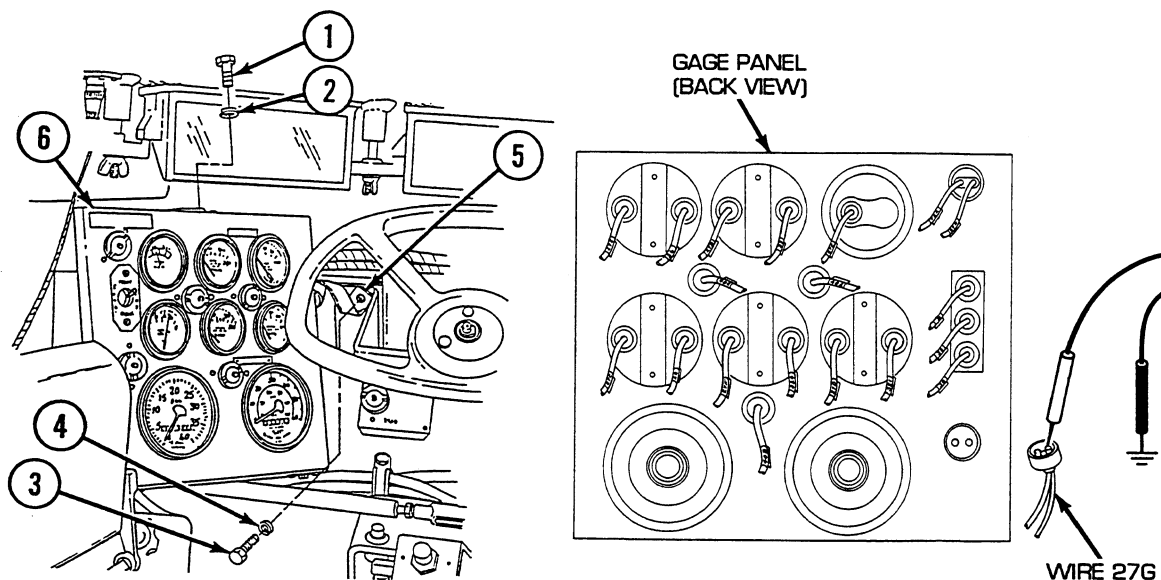

CORRECTIVE ACTION –Continued

2. Reconnect connector to master warning light. Disconnect gage panel to bulkhead wiring harness from gage panel. Place red lead of multimeter in socket K of wire 27 and black lead to ground. Turn MASTER switch on, and check for voltage. Turn MASTER switch OFF. If voltage is present, repair/replace wire 27/27G of gage panel wiring harness (see WP 0193 00). If voltage is not present, go to step 3.

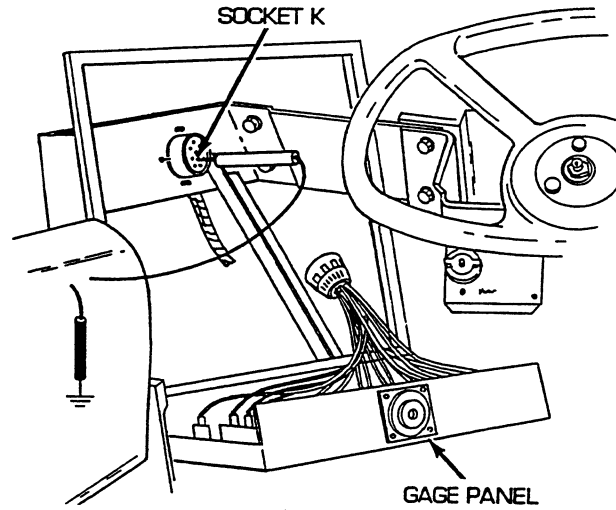

3. Install ground strap (5), two lockwashers (4), two screws (3), gage panel (6), three lockwashers (2), and three screws (1) to mounting brackets. Remove three screws (7), three lockwashers (8), ground lead (9), and flat washer (10), and release switch panel (11) from mounting brackets.

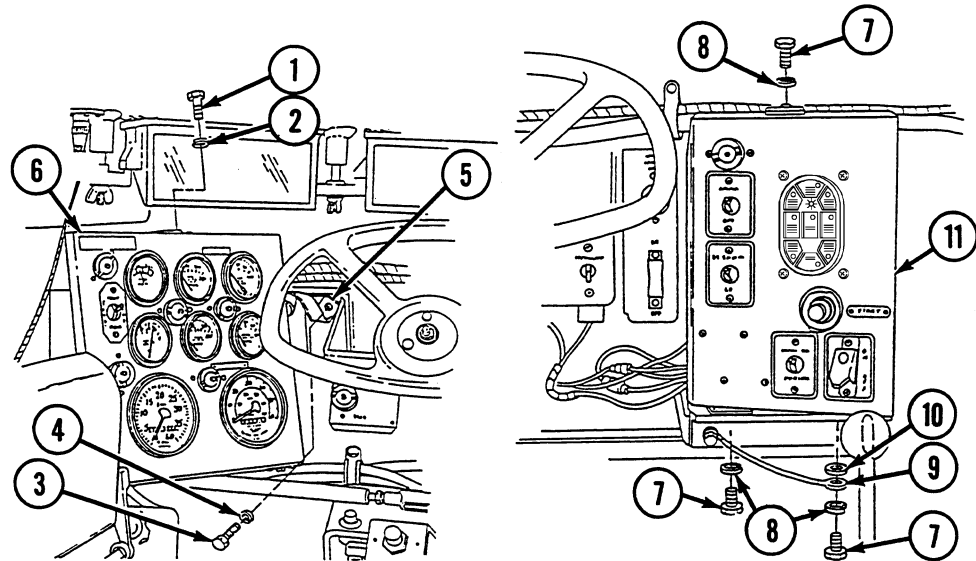

CORRECTIVE ACTION –Continued

Disconnect switch panel to gage panel and miscellaneous switches wiring harness from switch panel. Place red lead of multimeter on pin N and black lead to ground. Turn MASTER switch on and check for voltage. Turn MASTER switch OFF. If voltage is present, go to step 5. If voltage is not present, go to step 4.

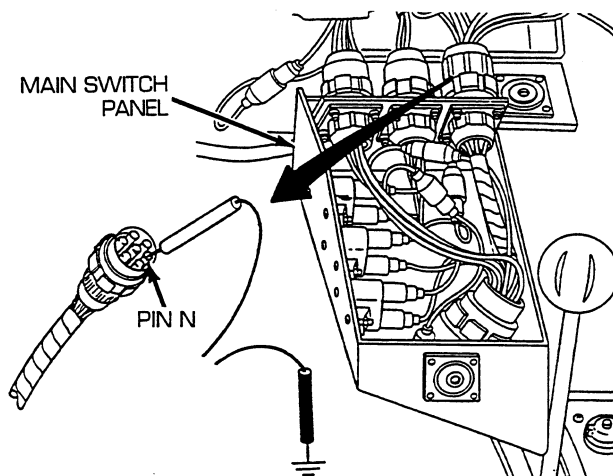

4. Reconnect switch panel to gage panel and miscellaneous switches wiring harness to switch panel. Install main switch panel (11), flat washer (10), ground lead (9), three lockwashers (8), and three screws (7) to mounting brackets. Open air inlet doors (TM 9-2350-256-10). Disconnect switch panel, radio, and bilge pump to bulkhead wiring harness from bulkhead disconnect. Place red lead of multimeter on pin A of wire 48 and black lead to ground. Turn MASTER switch on and check for voltage. Turn MASTER switch OFF. If voltage is present, repair/replace switch panel, radio, and bilge pump to bulkhead wiring harness (see WP 0202 00). If voltage is not present, troubleshoot master relay (see WP 0042 00).

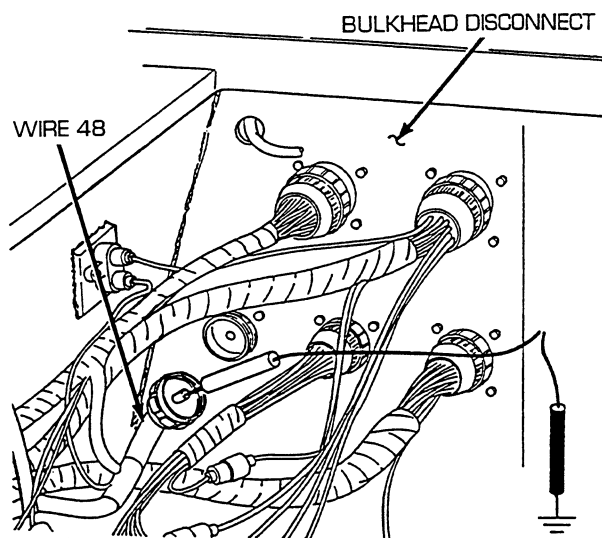

CORRECTIVE ACTION –Continued

5. Place jumper wire from socket N to pin N. Place red lead of multimeter in socket K of switch panel and black lead to ground. Turn MASTER switch on and check for voltage. Turn MASTER switch OFF. If voltage is present, go to step 6. If voltage is not present, go to step 8.

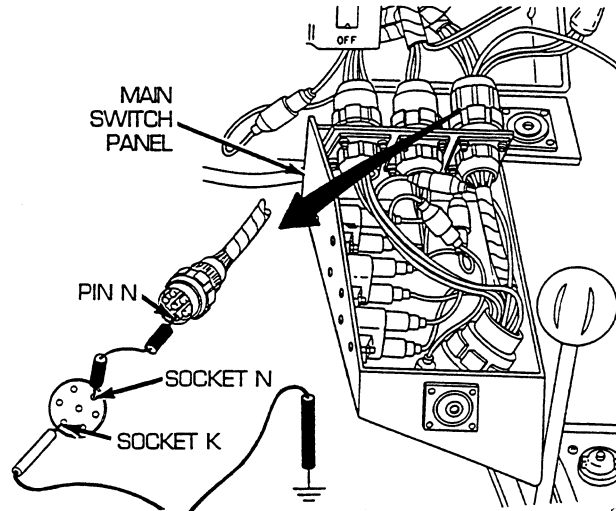

6. Reconnect switch panel to gage panel and miscellaneous switches wiring harness to main switch panel. Disconnect wire 27 from Y-connector. Place red multimeter lead on wire 27 and black lead to ground. Turn MASTER switch on and check for voltage. Turn MASTER switch OFF. If voltage is present, go to step 7. If voltage is not present, repair/replace wire 27 of switch panel to gage panel and miscellaneous switches wiring harness (see WP 0204 00 for dual voltage; 0205 00 for single voltage).

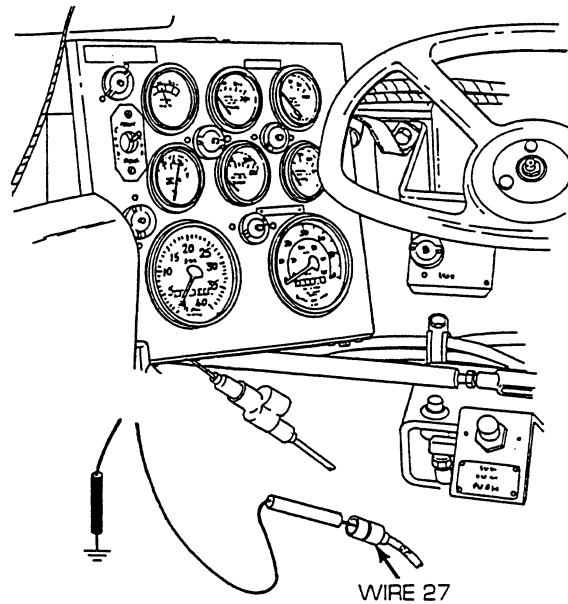

CORRECTIVE ACTION –Continued

7. Reconnect wire 27 at Y-connector. Install main switch panel (11), flat washer (10), ground lead (9), three lockwashers (8), and three screws (7) to mounting brackets. Remove three screws (1), three lockwashers (2), two screws (3), two lockwashers (4), and ground strap, and release gage panel (6) from mounting bracket.

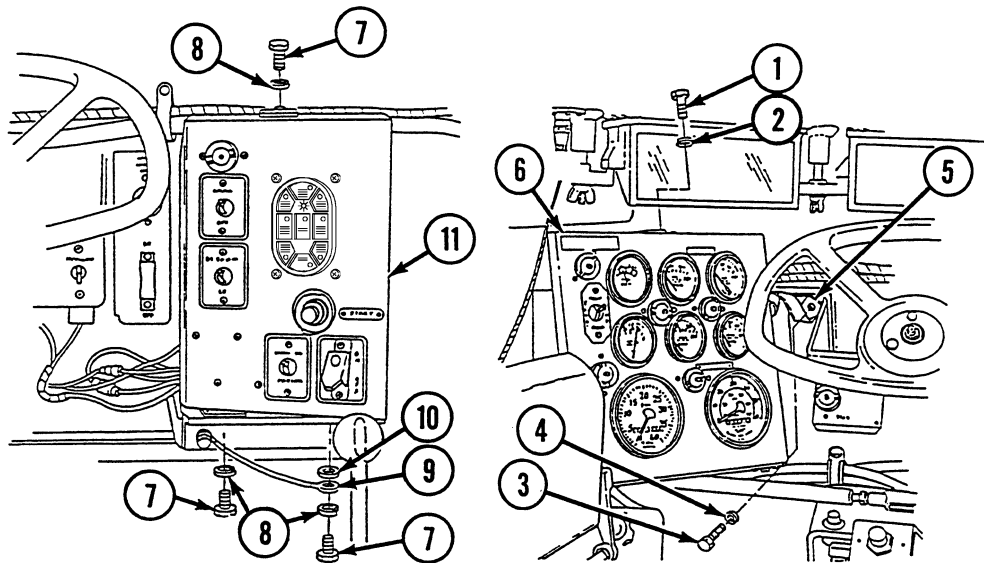

Disconnect switch panel to gage panel and miscellaneous switches wiring harness from gage panel. Place red multimeter lead in socket K and black lead to ground. Turn MASTER switch on and check for voltage. Turn MASTER switch OFF. If voltage is present, go to step 12. If voltage is not present, repair/replace wire 27 of switch panel to gage panel and miscellaneous switches wiring harness (see WP 0204 00 for dual voltage; 0205 00 for single voltage).

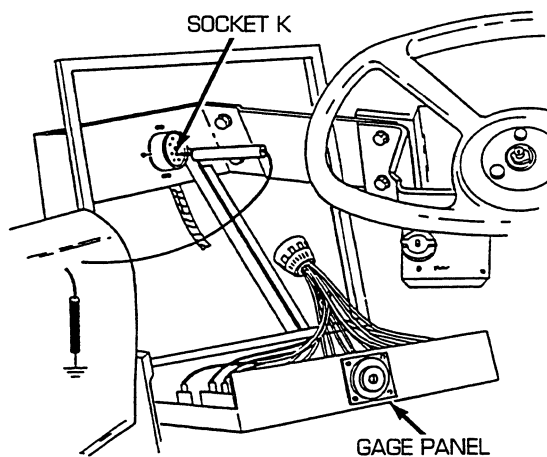

CORRECTIVE ACTION –Continued

8. Reconnect switch panel to gage panel and miscellaneous switches wiring harness to switch panel. Disconnect wire 10 from 15 A circuit breaker. Place red lead of multimeter on wire 10 and black lead to ground. Turn MASTER switch on and check for voltage. Turn MASTER switch OFF. If voltage is present, go to step 9. If voltage is not present, repair/replace wire 10 of switch panel to gage panel and miscellaneous switches wiring harness (see WP 0204 00 for dual voltage; 0205 00 for single voltage).

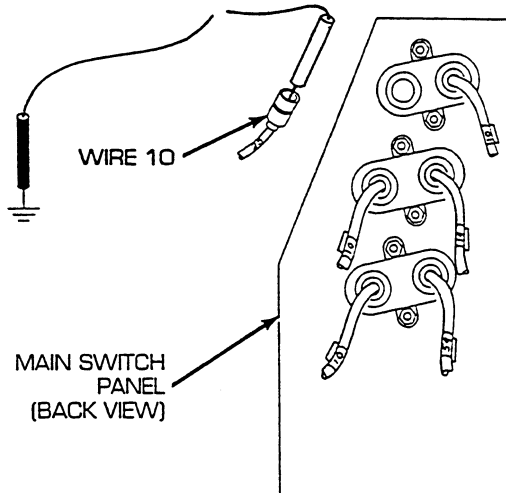

9. Reconnect wire 10 to 15 A circuit breaker. Disconnect wire 25-27 from 15 A circuit breaker. Place red lead of multimeter on terminal of circuit breaker and black lead to ground. Turn MASTER switch on and check for voltage. Turn MASTER switch OFF. If voltage is not present, replace 15 A circuit breaker (see WP 0159 00). If voltage is present, go to step 10.

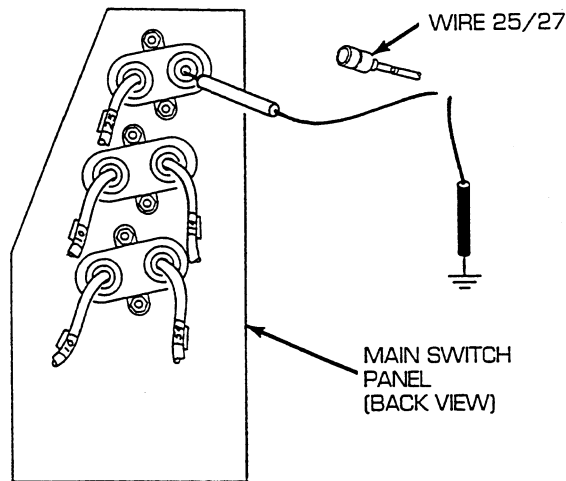

CORRECTIVE ACTION –Continued

10. Reconnect wire 25-27 to 15 A circuit breaker. Disconnect main lighting and B.O. selector switch wiring harness from main switch panel. Place red lead of multimeter on pin K of wire 25-27 and black lead to ground. Turn MASTER switch on and check for voltage. Turn MASTER switch OFF. If voltage is present, go to step 11. If voltage is not present, repair/replace wire 25-27 of main lighting and B.O. selector switch wiring harness (see WP 0218 00).

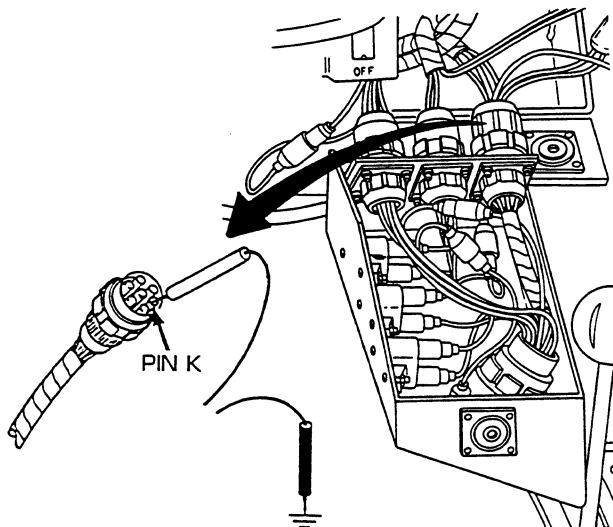

11. Place a jumper wire from wire 27G to terminal of master warning light. Place red lead of multimeter in wire 509 and black lead to ground. Turn MASTER switch on, start engine, set to idle, and check for voltage. Turn engine and MASTER switch OFF. If voltage is present, replace lamp (see WP 0157 00). If voltage is not present, go to step 12.

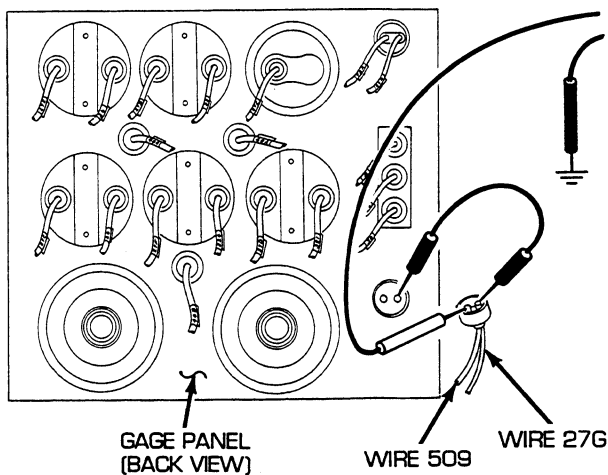

CORRECTIVE ACTION –Continued

12. Reconnect connector to master warning light. Disconnect gage panel to bulkhead wiring harness from gage panel. Place a jumper wire from pin K to socket K. Place red lead of multimeter in pin A of wire 509 and black lead to ground. Turn MASTER switch on, start engine, set to idle, and check for voltage. Turn engine and MASTER switch OFF. If voltage is present, repair/replace wire 509 of gage panel wiring harness (see WP 0193 00). If voltage is not present, reconnect gage panel to bulkhead wiring harness and go to step 13.

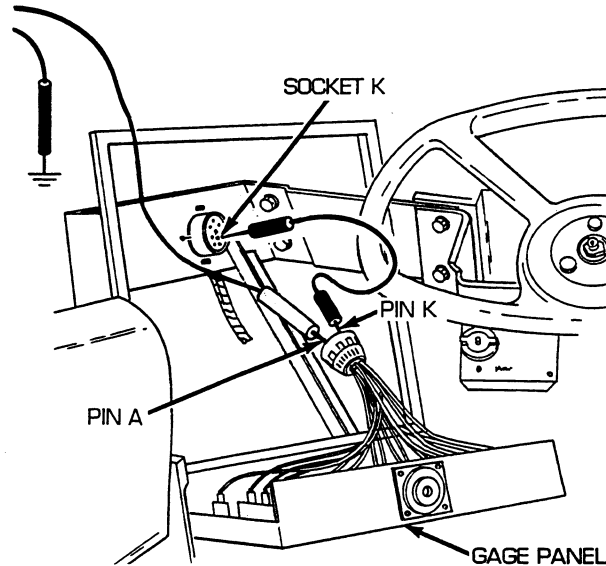

13. Open air inlet doors. Disconnect bulkhead to engine bracket and rear fuel tank transmitter wiring harness from bulkhead disconnect. Place red lead of multimeter in socket H of wire 509 and black lead to ground. Turn MASTER switch on, start engine, set to idle, and check for voltage. Turn engine and MASTER switch OFF. If voltage is present, go to step 14. If voltage is not present, repair/replace wire 509 of gage panel to bulkhead wiring harness from gage panel to bulkhead (see WP 0194 00 for dual voltage; 0195 00 for single voltage).

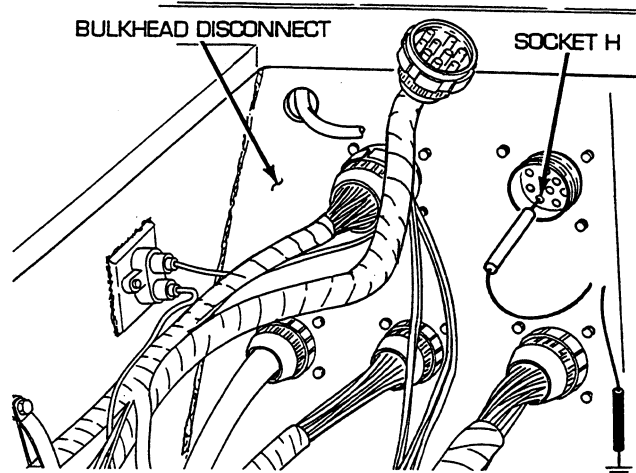

CORRECTIVE ACTION –Continued

14. Reconnect gage panel to bulkhead wiring harness to bulkhead disconnect. Remove engine deck (see WP 0336 00). Disconnect bulkhead to engine bracket and rear fuel tank transmitter wiring harness from engine disconnect. Place a jumper wire from pin M to socket M. Place red lead of multimeter in socket N of wire 509 and black lead to ground. Turn MASTER switch on, start engine, set to idle, and check for voltage. Turn engine and MASTER switch OFF. If voltage is present, go to step 15. If voltage is not present, repair/replace wire 509 of bulkhead to engine bracket and rear fuel tank transmitter wiring harness (see WP 0222 00 for dual voltage; 0223 00 for single voltage).

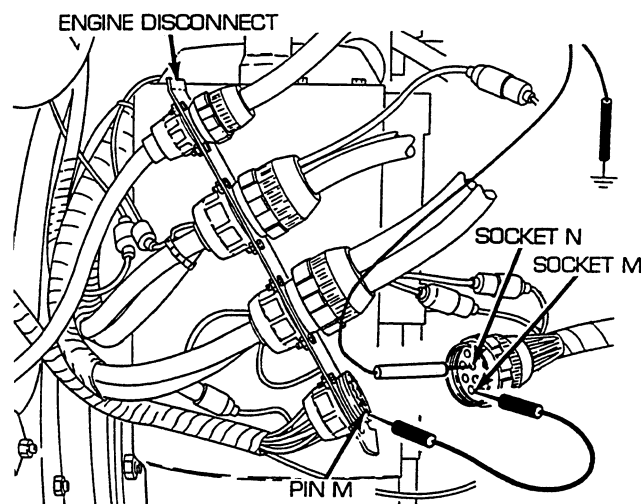

15. Reconnect bulkhead to engine bracket and rear fuel tank transmitter wiring harness to engine disconnect. Remove powerplant (see WP 0098 00). Disconnect wire 509 from engine low oil pressure switch. Place red lead of multimeter in wire 509 and black lead to ground. Turn MASTER switch on, start engine, set to idle, and check for voltage. Turn engine and MASTER switch OFF. If voltage is present, replace engine low oil pressure switch (see WP 0171 00). If voltage is not present, repair/replace wire 509 of engine wiring harness from engine low oil pressure switch to engine disconnect (see WP 0207 00 for dual voltage; 0208 00 for single voltage).

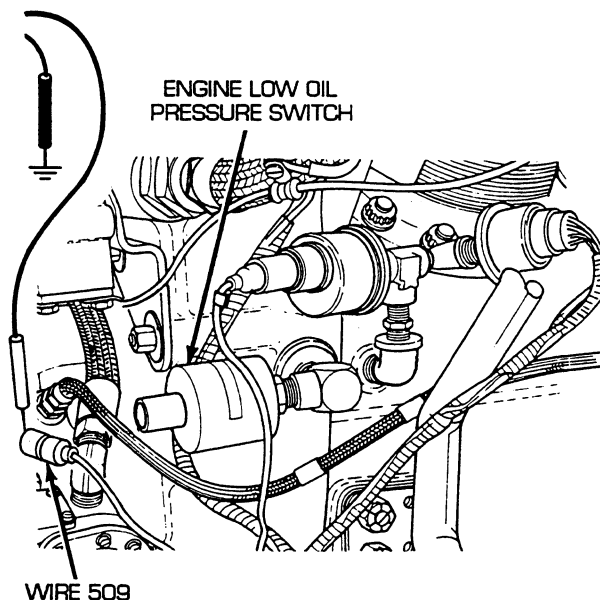

CORRECTIVE ACTION –Continued

16. Disconnect wire 509 from transmission high oil temperature switch. Place red lead of multimeter in wire 509 and black lead to ground. Turn MASTER switch on, start engine, set to idle, and check for voltage. Turn engine and MASTER switch OFF. If voltage is present, replace transmission high oil temperature switch (see WP 0168 00). If voltage is not present, repair/replace wire 509 of engine wiring harness from transmission high oil temperature switch to engine disconnect (see WP 0207 00 for dual voltage; 0208 00 for single voltage).

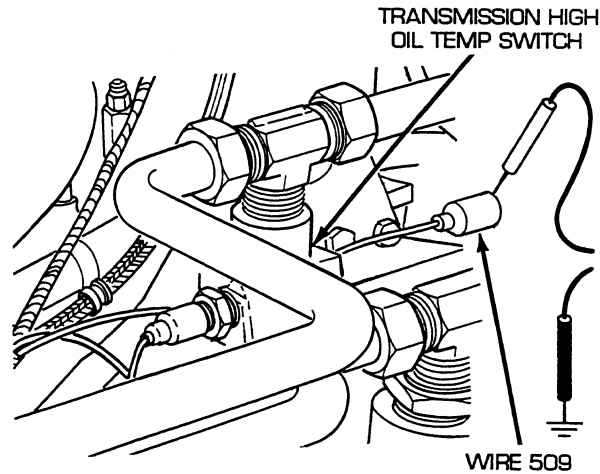

17. Remove powerplant and groundhop (see WP 0098 00 and 0099 00). Disconnect wire 509 from engine high oil temperature switch. Place red lead of multimeter in wire 509 and black lead to ground. Turn MASTER switch on, start engine, and check for voltage. Turn engine and MASTER switch OFF. If voltage is present, replace engine high oil temp switch. If voltage is not present, repair/replace wire 509 of engine wiring harness from engine high oil temperature switch to engine disconnect (see WP 0207 00 for dual voltage; 0208 00 for single voltage).

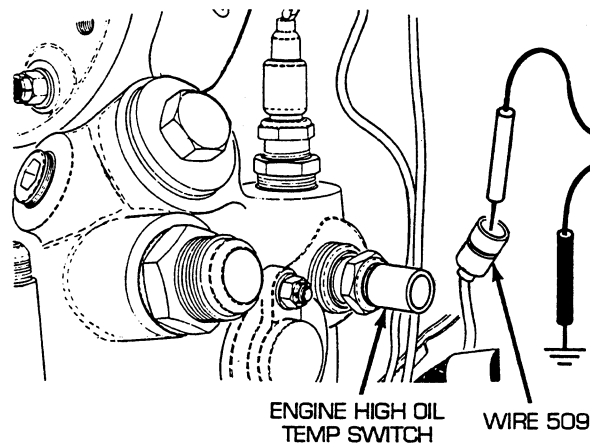
**END OF WORK PACKAGE**

UNIT MAINTENANCE
RECOVERY VEHICLE, FULL TRACKED: MEDIUM, M88A1
NSN 2350-00-122-6826, EIC AQA
POWERPLANT WARNING HORN TROUBLESHOOTING PROCEDURE

INITIAL SETUP:**Tools and Special Tools**

Tool kit, general mechanic's (item 59, WP 0490 00)

References

WP 0098 00
WP 0150 00
WP 0168 00
WP 0170 00
WP 0171 00
WP 0194 00
WP 0195 00

References (cont.)

WP 0207 00
WP 0208 00
WP 0222 00
WP 0223 00
WP 0224 00
WP 0225 00
WP 0228 00
WP 0229 00
WP 0336 00
TM 9-2350-256-10

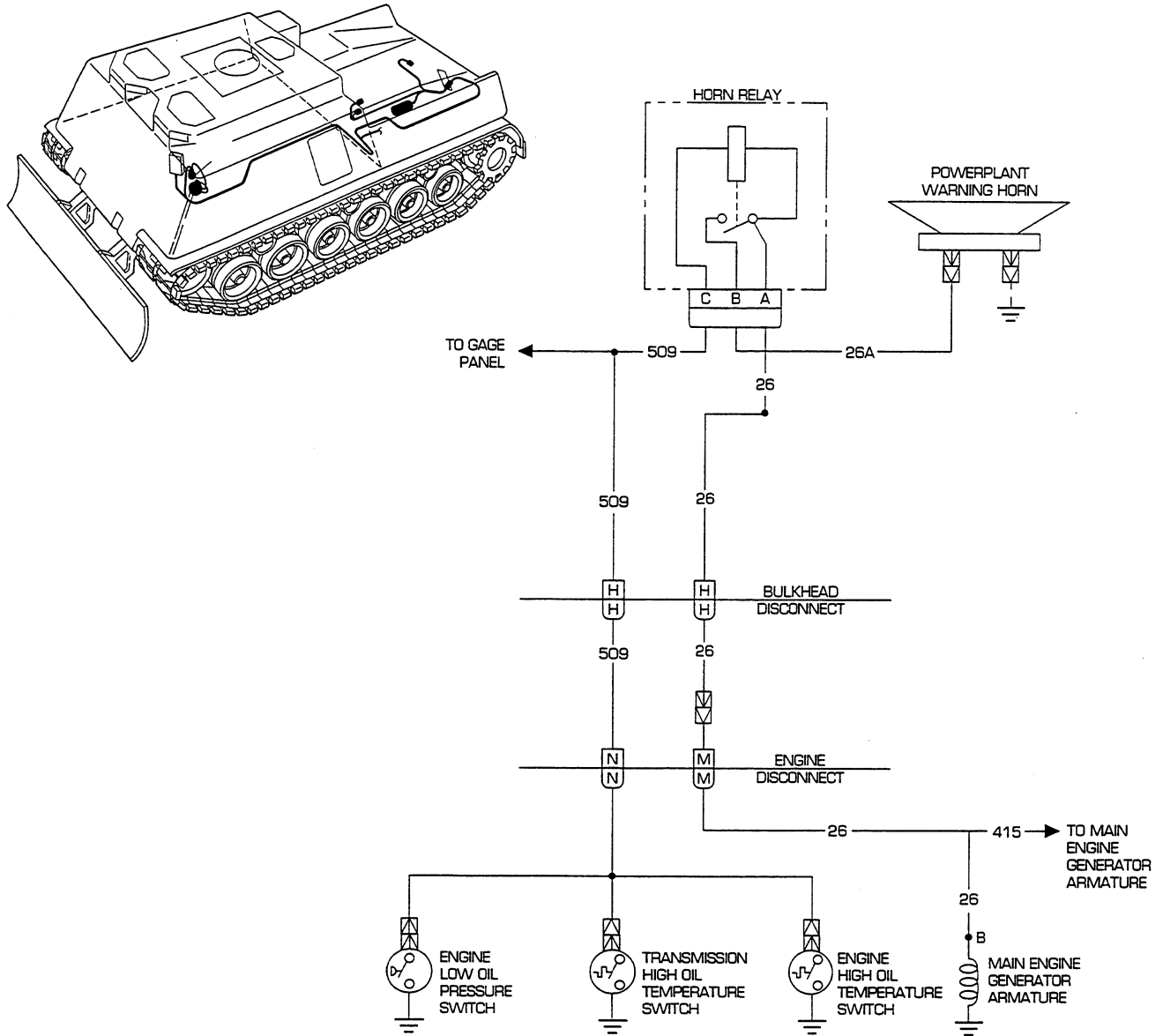

Troubleshooting Procedure

Powerplant Warning Horn

Symptom

Powerplant warning horn malfunctioning.

Malfunction

Powerplant warning horn fails to operate. Do steps 1 thru 15.

CORRECTIVE ACTION

WARNING

Remove all jewelry such as rings, dog tags, bracelets, etc. If jewelry contacts a metal surface a direct short may result in instant heating of tools, damage to equipment, and injury or death to personnel.

1. Disconnect gage panel to bulkhead wiring harness from warning horn relay. Place red lead of multi-meter in socket A of wire 26 and black lead to ground. Turn MASTER switch on, start engine, set to idle, and check for voltage. Turn engine and MASTER switch OFF. If voltage is present, go to step 7. If voltage is not present, go to step 2.

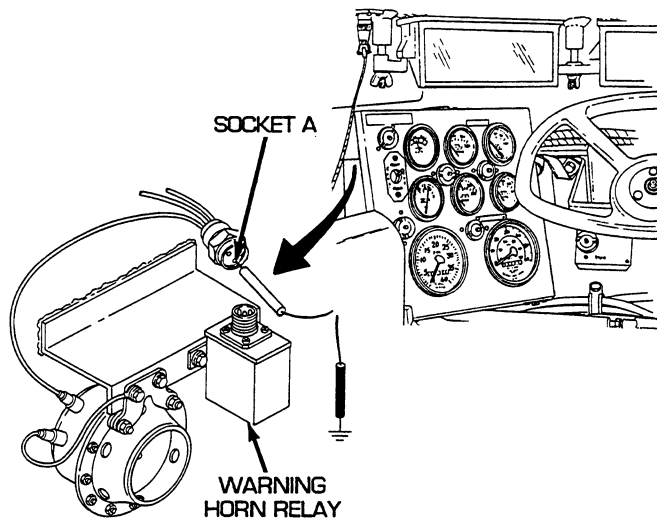

2. Reconnect gage panel to bulkhead wiring harness to warning horn relay. Open air inlet doors (TM 9-2350-256-10). Disconnect bulkhead to APU, master relay, and rigger's lights wiring harness from bulkhead. Place red lead of multimeter in socket H of wire 26 and black lead to ground. Turn MASTER switch on, start engine, set to idle, and check for voltage. Turn engine and MASTER switch OFF. If voltage is present, go to step 3. If voltage is not present, go to step 4.

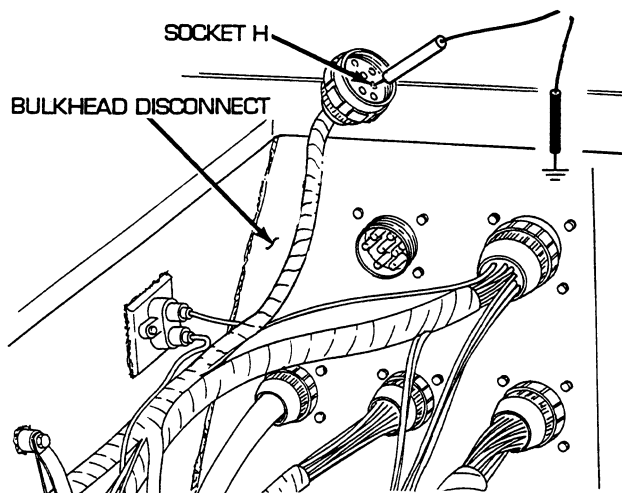

CORRECTIVE ACTION –Continued

3. Reconnect APU control box to foot dimmer switch and bulkhead wiring harness to bulkhead. Disconnect wire 26 of gage panel to bulkhead wiring harness from APU control box to foot dimmer switch and bulkhead wiring harness. Place red lead of multimeter in female connector of wire 26 and black lead to ground. Turn MASTER switch on, start engine, set to idle, and check for voltage. Turn engine and MASTER switch OFF. If voltage is present, repair/replace wire 26 of gage panel to bulkhead wiring harness (see WP 0194 00 for dual voltage; 0195 00 for single voltage). If voltage is not present, repair/replace wire 26 of APU control box to foot dimmer switch and bulkhead wiring harness (see WP 0228 00 for dual voltage; 0229 00 for single voltage).

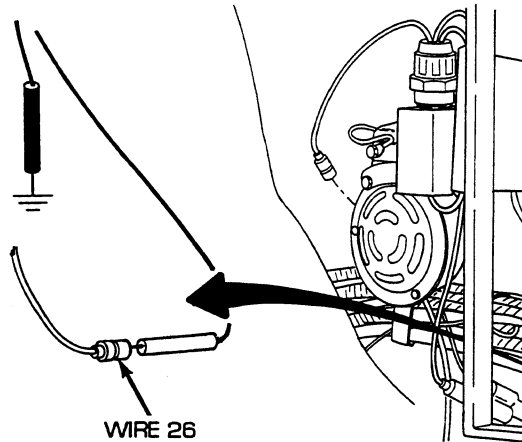

4. Reconnect APU control box to foot dimmer switch and bulkhead wiring harness to bulkhead. Remove engine deck (see WP 0336 00). Disconnect bulkhead to engine bracket and rear fuel tank transmitter wiring harness from engine disconnect. Place red lead of multimeter on pin M of wire 26 and black lead to ground. Turn MASTER switch on, start engine, set to idle, and check for voltage. Turn engine and MASTER switch OFF. If voltage is present, go to step 5. If voltage is not present, go to step 6.

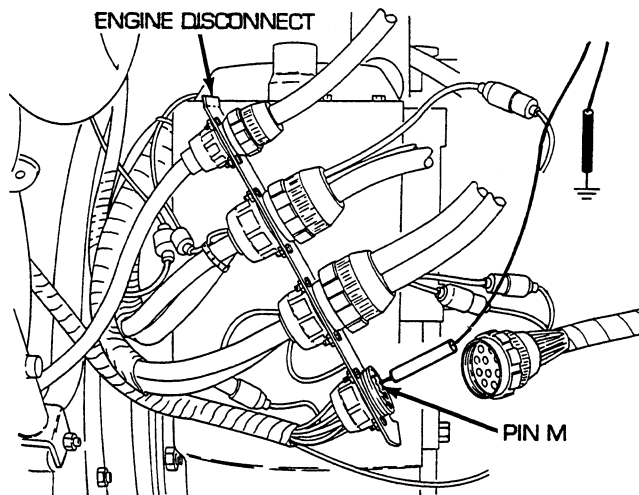

CORRECTIVE ACTION –Continued

5. Reconnect bulkhead to engine bracket and rear fuel tank transmitter wiring harness to engine disconnect. Disconnect wire 26 of bulkhead to APU, master relay, and rigger's lights wiring harness from bulkhead to engine bracket and rear fuel tank transmitter wiring harness. Place red lead of multimeter in female connector of wire 26 and black lead to ground. Turn MASTER switch on, start engine, set to idle, and check for voltage. Turn engine and MASTER switch OFF. If voltage is present, repair/replace wire 26 of bulkhead to APU, master relay, and rigger's lights wiring harness (see WP 0224 00 for dual voltage; 0225 00 for single voltage). If voltage is not present, repair/replace wire 26 of bulkhead to engine bracket and rear fuel tank transmitter wiring harness (see WP 0222 00 for dual voltage; 0223 00 for single voltage).

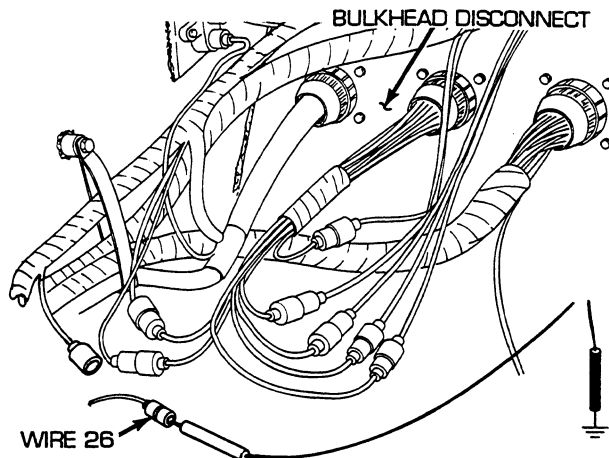

6. Remove powerplant (see WP 0098 00). Place red lead of multimeter on pin M of wire 26 and black lead of multimeter on wire 26. Check for continuity. If continuity is present, replace generator (see WP 0150 00). If continuity is not present, repair/replace wire 26 of engine wiring harness (see WP 0207 00 for dual voltage; 0208 00 for single voltage).

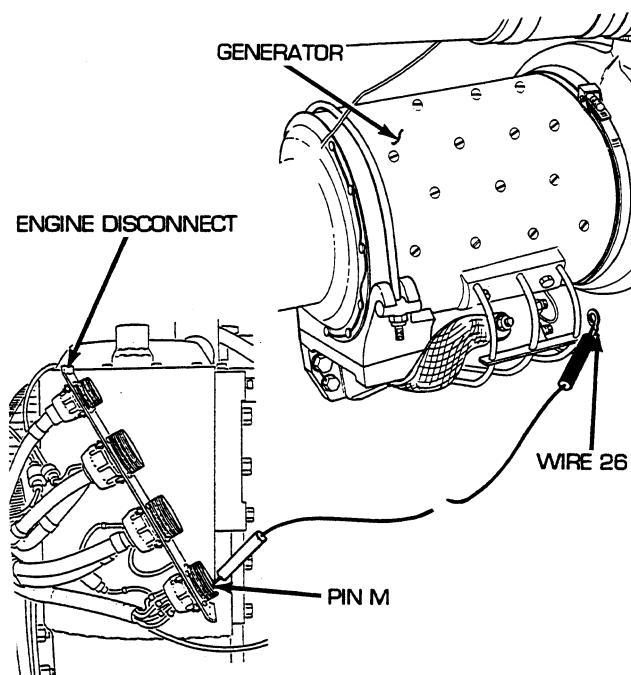

CORRECTIVE ACTION –Continued

7. Place red lead of multimeter on pin A and black lead on pin C of horn relay. Check for continuity. If continuity is present, go to step 8. If continuity is not present, go to step 11.

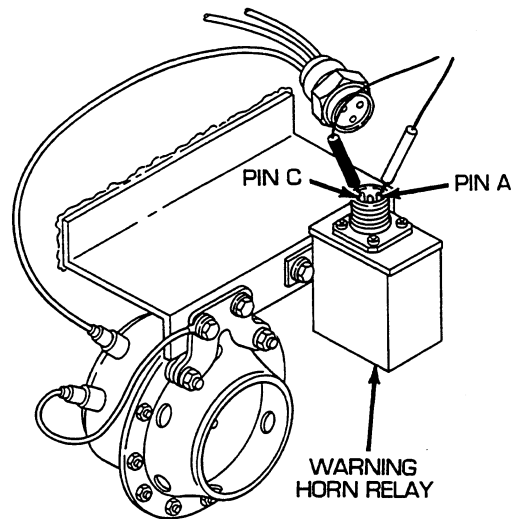

8. Place a jumper wire from pin C to socket C. Place red lead of multimeter on pin B of warning horn relay and black lead to ground. Turn MASTER switch on, start engine, set to idle, and check for voltage. Turn engine and MASTER switch OFF. If voltage is present, go to step 9. If voltage is not present, replace warning horn relay (see WP 0170 00).

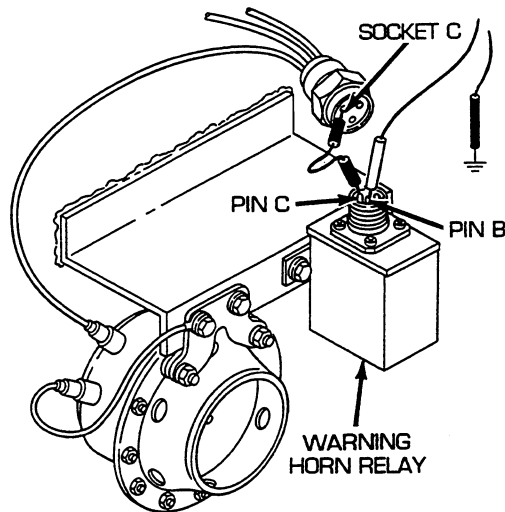

CORRECTIVE ACTION –Continued

9. Reconnect gage panel to bulkhead wiring harness to warning horn relay. Disconnect wire 26A from warning horn. Place red lead of multimeter in wire 26A and black lead to ground. Turn MASTER switch on, start engine, set to idle, and check for voltage. Turn engine and MASTER switch OFF. If voltage is present, go to step 10. If voltage is not present, replace/ repair wire 26A of gage panel to bulkhead wiring harness (see WP 0194 00 for dual voltage; 0195 00 for single voltage).

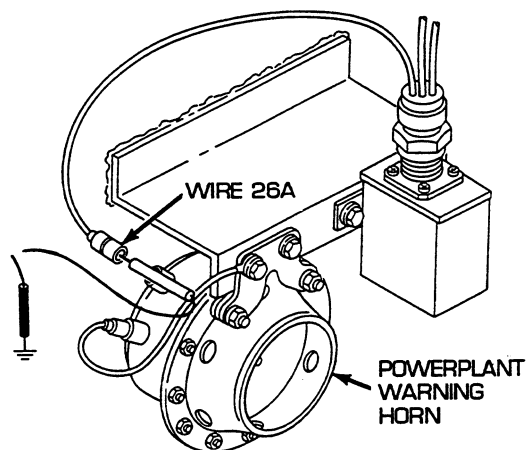

10. Disconnect GND lead from warning horn assembly. Place red lead of multimeter in GND lead and black lead to ground. Check for continuity. If continuity is not present, replace warning horn assembly (see WP 0170 00). If continuity is present, repair/replace warning horn ground lead (see WP 0170 00).

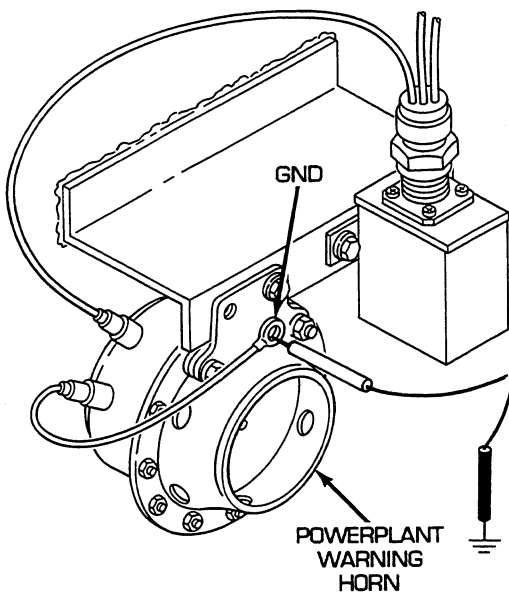

CORRECTIVE ACTION –Continued

11. Reconnect gage panel to bulkhead wiring harness to warning horn relay. Open air inlet doors. Disconnect bulkhead to engine bracket and rear fuel tank transmitter wiring harness from bulkhead disconnect. Place red lead of multimeter in socket H of wire 509 and black lead to ground. Turn MASTER switch on, start engine, set to idle, and check for voltage. Turn engine and MASTER switch OFF. If voltage is present, go to step 12. If voltage is not present, repair/replace wire 509 of gage panel to bulkhead wiring harness (see WP 0194 00 for dual voltage; 0195 00 for single voltage).

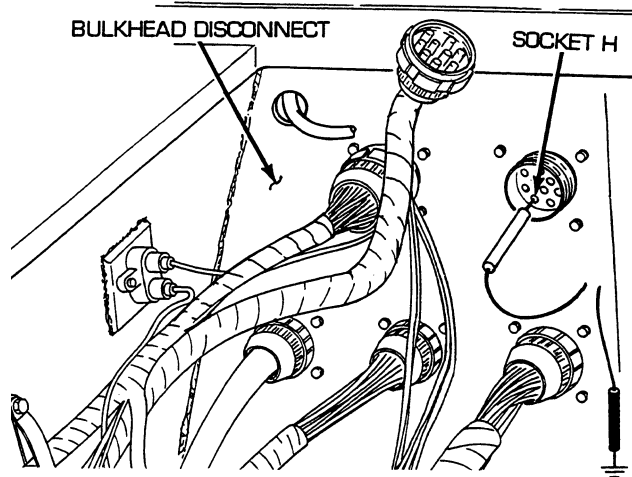

12. Reconnect gage panel to bulkhead wiring harness to bulkhead disconnect. Remove engine deck (see WP 0336 00). Disconnect bulkhead to engine bracket and rear fuel tank transmitter wiring harness from engine disconnect. Place a jumper wire from pin M to socket M. Place red lead of multimeter in socket N of wire 509 and black lead to ground. Turn MASTER switch on, start engine, set to idle, and check for voltage. Turn engine and MASTER switch OFF. If voltage is present, go to step 13. If voltage is not present, repair/replace wire 509 of bulkhead to engine bracket and rear fuel tank transmitter wiring harness (see WP 0222 00 for dual voltage; 0223 00 for single voltage).

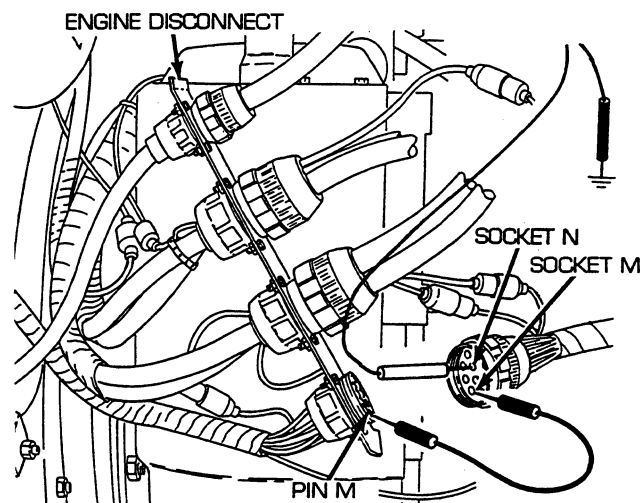

CORRECTIVE ACTION –Continued

13. Reconnect bulkhead to engine bracket and rear fuel tank transmitter wiring harness to engine disconnect. Remove powerplant (see WP 0098 00). Disconnect wire 509 from engine high oil temperature switch. Place red lead of multimeter in wire 509 and black lead to ground. Turn MASTER switch on, start engine, set to idle, and check for voltage. Turn engine and MASTER switch OFF. If voltage is present, replace engine high oil temperature switch (see WP 0171 00). If voltage is not present, go to step 14.

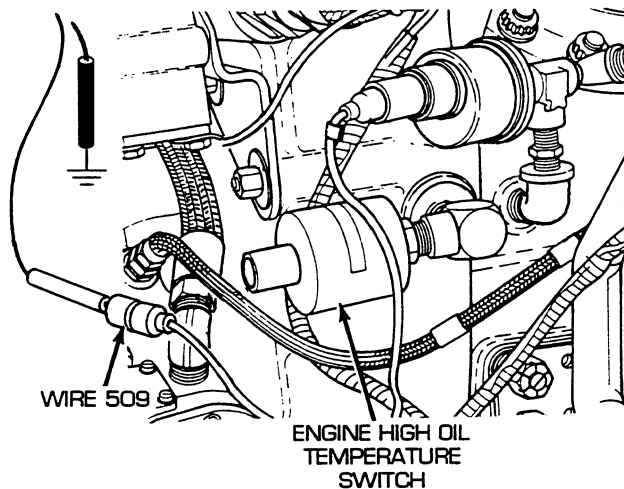

14. Disconnect wire 509 from engine low oil pressure switch. Place red lead of multimeter in wire 509 and black lead to ground. Turn MASTER switch on, start engine, set to idle, and check for voltage. Turn engine and MASTER switch OFF. If voltage is present, replace engine low oil pressure switch (see WP 0171 00). If voltage is not present, go to step 15.

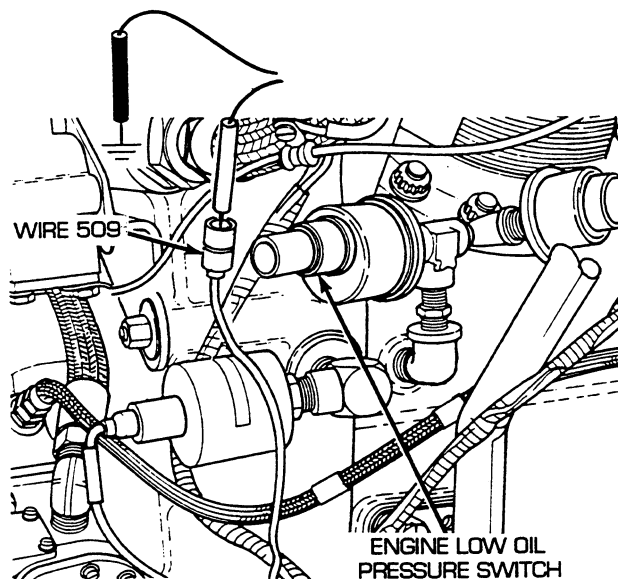

CORRECTIVE ACTION –Continued

15. Disconnect wire 509 from transmission high oil temperature switch. Place red lead of multimeter in wire 509 and black lead to ground. Turn MASTER switch on, start engine, set to idle, and check for voltage. Turn engine and MASTER switch OFF. If voltage is present, replace transmission high oil temperature switch (see WP 0168 00). If voltage is not present at any of the switches, repair/replace wire 509 of engine wiring harness (see WP 0207 00 for dual voltage; 0208 00 for single voltage).

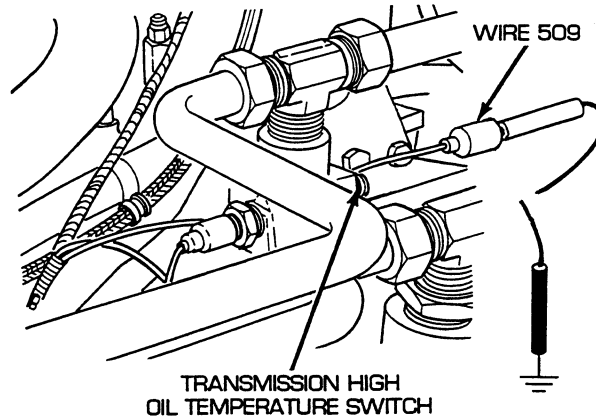
**END OF WORK PACKAGE**

UNIT MAINTENANCE
RECOVERY VEHICLE, FULL TRACKED: MEDIUM, M88A1
NSN 2350-00-122-6826, EIC AQA
EXTERNAL VEHICLE WARNING HORN TROUBLESHOOTING PROCEDURE

INITIAL SETUP:

Tools and Special Tools

Tool kit, general mechanic's (item 59, WP 0490 00)

References

- WP 0042 00
- WP 0159 00
- WP 0169 00

References (cont.)

- WP 0202 00
- WP 0204 00
- WP 0205 00
- WP 0218 00
- TM 9-2350-256-10

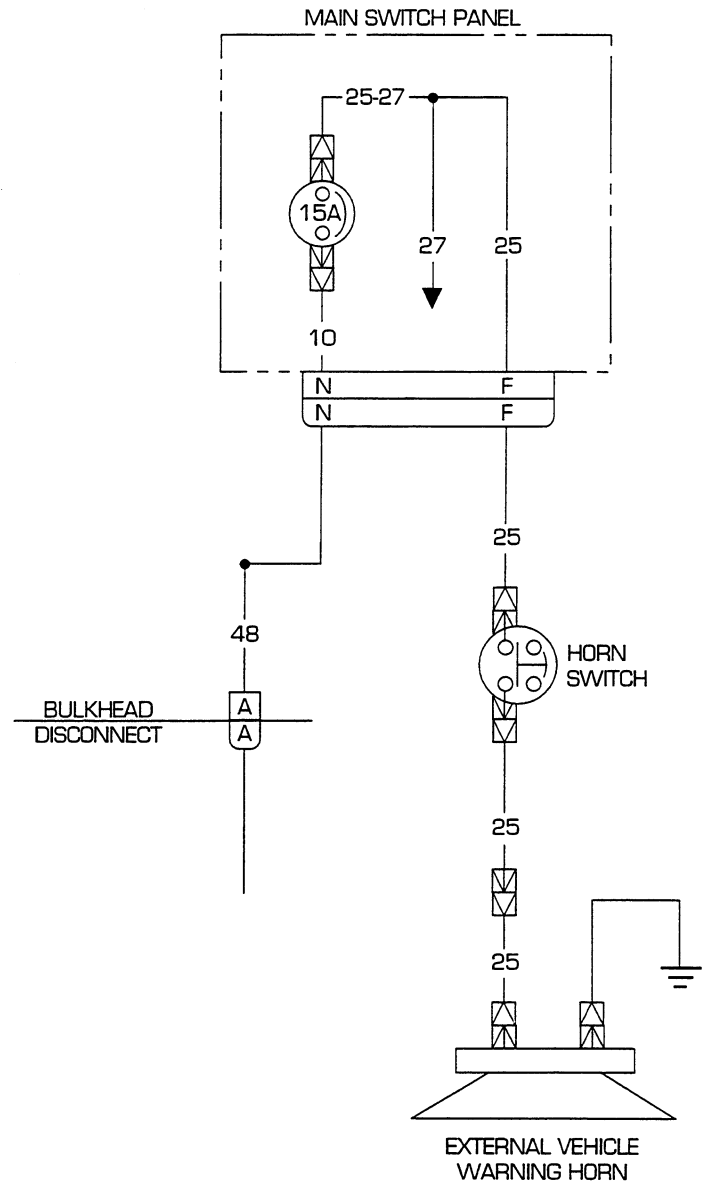
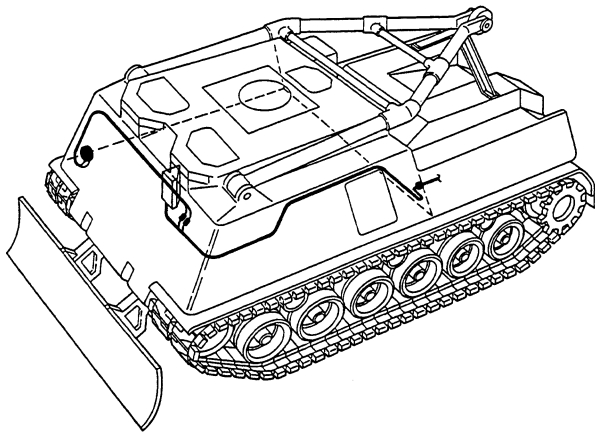

Troubleshooting Procedure

External Vehicle Warning Horn

Symptom

External vehicle warning horn malfunctioning.

Malfunction

External vehicle warning horn fails to operate. Do steps 1 thru 9.

CORRECTIVE ACTION

WARNING

Remove all jewelry such as rings, dog tags, bracelets, etc. If jewelry contacts a metal surface a direct short may result in instant heating of tools, damage to equipment, and injury or death to personnel.

1. Remove three screws (1), three lockwashers (2), ground lead (3), and flat washer (4), and release main switch panel (5) from mounting brackets. Disconnect switch panel to gage panel and miscellaneous switches wiring harness from main switch panel. Place red lead of multimeter on pin N of wire 10 and black lead to ground. Turn MASTER switch on and check for voltage. Turn MASTER switch OFF. If voltage is present, go to step 3. If voltage is not present, go to step 2.

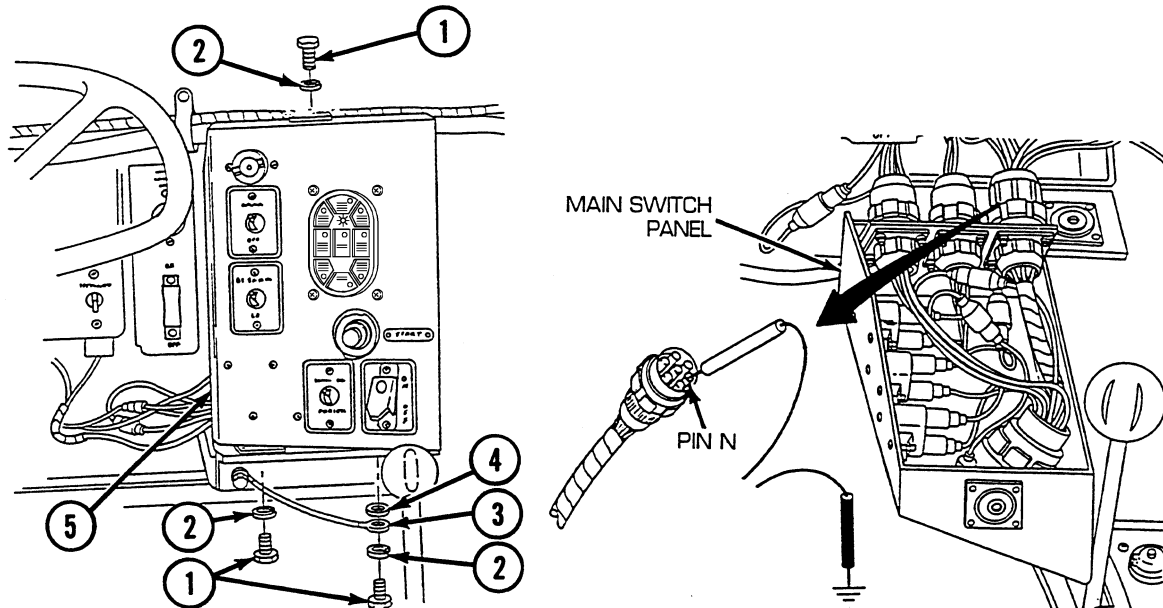

CORRECTIVE ACTION –Continued

2. Reconnect switch panel to gage panel and miscellaneous switches wiring harness to main switch panel. Install main switch panel (5), flat washer (4), ground lead (3), three lockwashers (2), and three screws (1) to mounting brackets. Open air inlet doors (TM 9-2350-256-10). Disconnect wire 48 pin A from bulkhead to master relay wiring harness. Place red multimeter lead on pin A and black lead to ground. Turn MASTER switch on and check for voltage. If voltage is present, repair/replace switch panel, radio, and bilge pump to bulkhead wiring harness (see WP 0202 00). If voltage is not present, troubleshoot master relay circuit (see WP 0042 00).

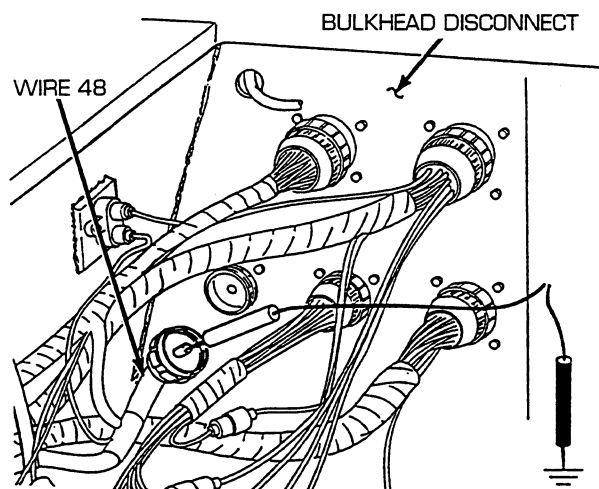

3. Place a jumper wire from pin N to socket N. Place red lead of multimeter in socket F of wire 25 and black lead to ground. Turn MASTER switch on and check for voltage. Turn MASTER switch OFF. If voltage is present, go to step 6. If voltage is not present, go to step 4.

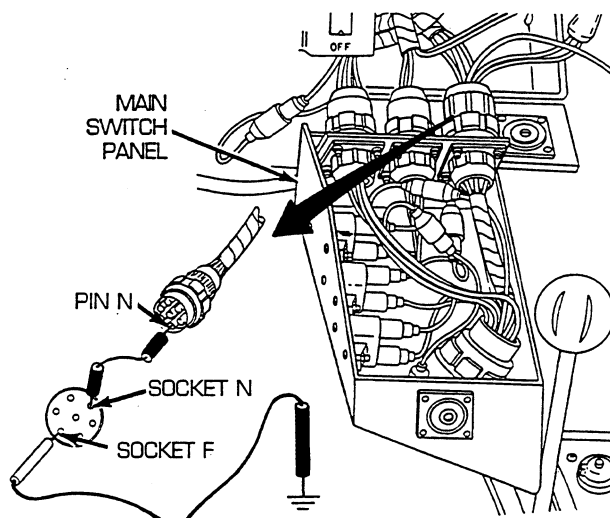

CORRECTIVE ACTION –Continued

4. Reconnect switch panel to gage panel and miscellaneous switches wiring harness to main switch panel. Disconnect wire 25/27 from 15 A circuit breaker. Place red lead of multimeter on terminal of 15 A circuit breaker and black lead to ground. Turn MASTER switch on and check for voltage. Turn MASTER switch OFF. If voltage repair/replace wire 25/27 of main lighting and B.O. selector switch wiring harness (see WP 0218 00). If voltage is not present, go to step 5.

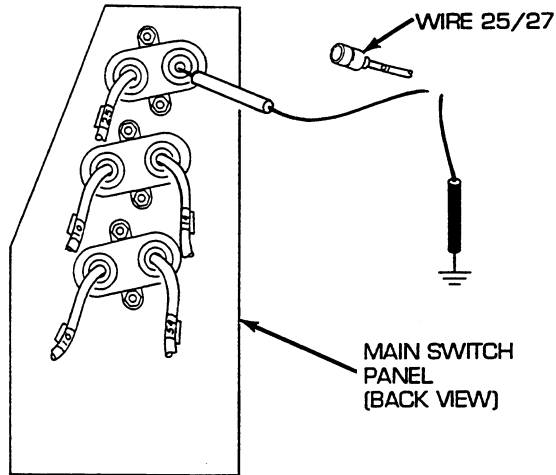

5. Reconnect wire 25/27 to 15 A circuit breaker. Disconnect wire 10 from 15 A circuit breaker. Place red lead of multimeter in wire 10 and black lead to ground. Turn MASTER switch on and check for voltage. Turn MASTER switch OFF. If voltage is present, replace circuit breaker (see WP 0159 00). If voltage is not present, repair/replace wire 10 of main lighting and B.O. selector switch wiring harness (see WP 0218 00).

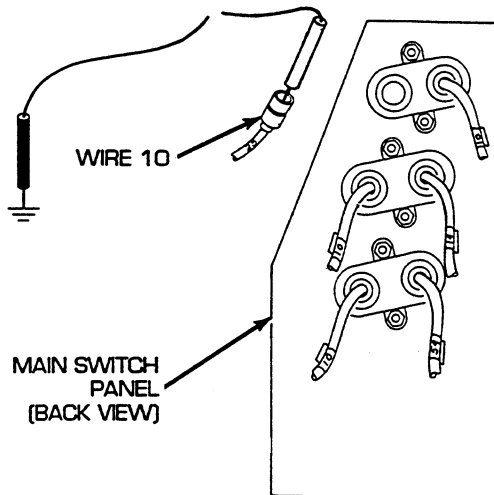

CORRECTIVE ACTION –Continued

6. Reconnect switch panel to gage panel and miscellaneous switches wiring harness to main switch panel. Disconnect wire 25 from main switch panel side of horn switch. Place red lead of multimeter in wire 25 and black lead to ground. Turn MASTER switch on and check for voltage. Turn MASTER switch OFF. If voltage is present, go to step 7. If voltage is not present, repair/replace wire 25 of switch panel to gage panel and miscellaneous switches wiring harness (see WP 0204 00 for dual voltage; 0205 00 for single voltage).

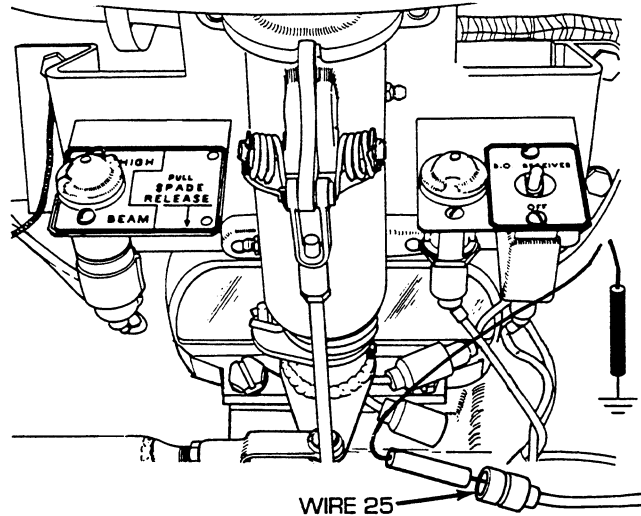

7. Reconnect wire 25 to main switch panel side of horn switch. Disconnect wire 25 from horn side of horn switch. Place red lead of multimeter on terminal of horn switch and black lead to ground. Turn MASTER switch on, push horn switch, and check for voltage. Turn MASTER switch OFF. If voltage is present, go to step 8. If voltage is not present, replace horn switch (see WP 0169 00).

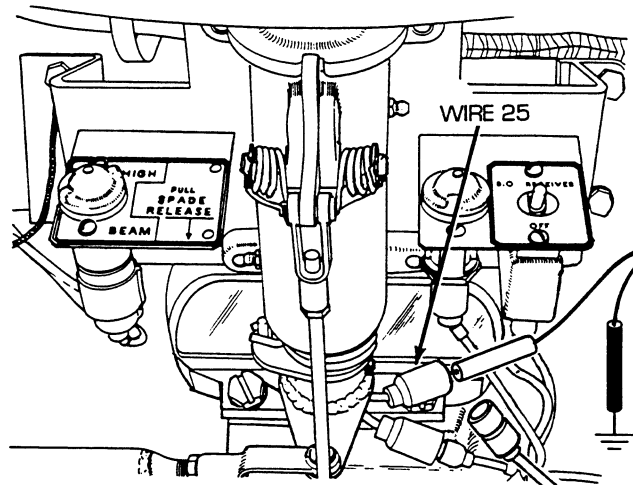

CORRECTIVE ACTION –Continued

8. Reconnect wire 25 to horn side of horn switch. Disconnect wire 25 from external vehicle horn. Place red lead of multimeter in wire 25 and black lead to ground. Turn MASTER switch on, push horn switch, and check for voltage. Turn MASTER switch OFF. If voltage is present, go to step 9. If voltage is not present, repair/replace wire 25 of horn switch to horn lead assembly (see WP 0169 00).

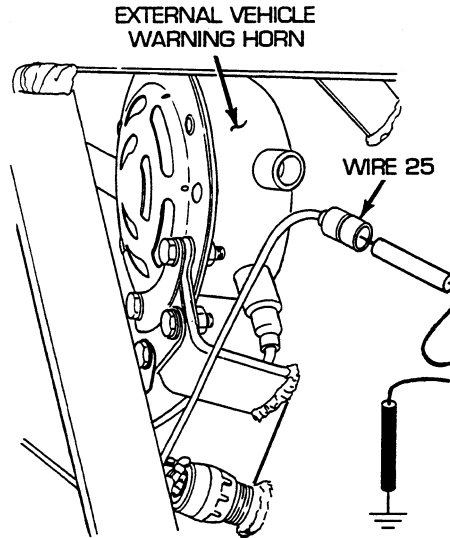

9. Reconnect wire 25 to external vehicle horn. Disconnect ground wire from external vehicle horn. Place red lead of multimeter on terminal of horn and black lead to ground. Turn MASTER switch on, push horn switch, and check for voltage. Turn MASTER switch OFF. If voltage is present, repair/replace ground wire (see WP 0169 00). If voltage is not present, replace external vehicle horn (see WP 0169 00).

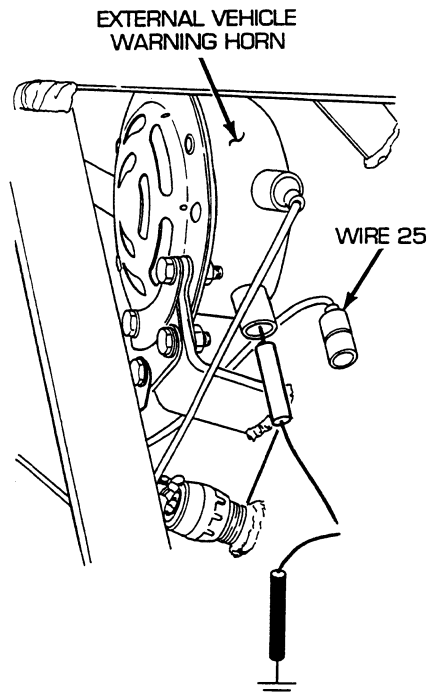

END OF WORK PACKAGE

UNIT MAINTENANCE
RECOVERY VEHICLE, FULL TRACKED: MEDIUM, M88A1
NSN 2350-00-122-6826, EIC AQA
BILGE PUMP SYSTEM AND ELECTRICAL ACCESSORIES PANEL POWER OUTLET
TROUBLESHOOTING PROCEDURE

INITIAL SETUP:**Tools and Special Tools**

Tool kit, general mechanic's (item 59, WP 0490 00)

References

WP 0042 00
WP 0158 00
WP 0196 00
WP 0202 00

References (cont.)

WP 0232 00
WP 0233 00
WP 0234 00
WP 0235 00
WP 0250 00
WP 0473 00
TM 9-2350-256-10

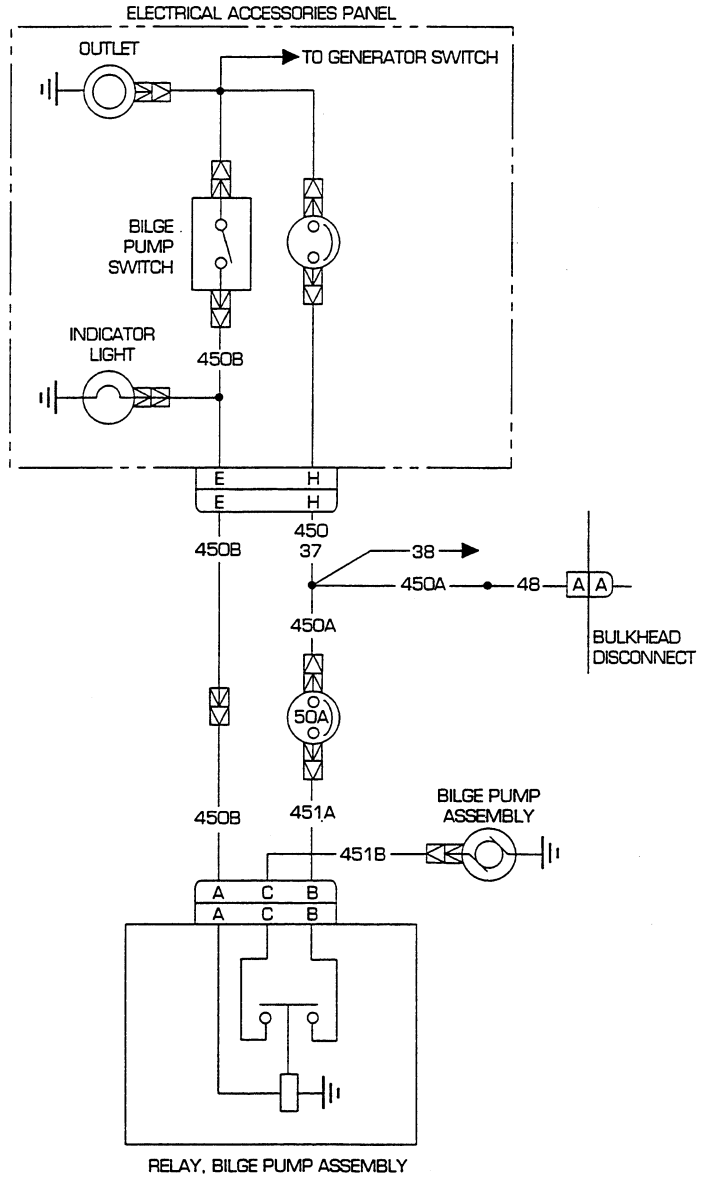
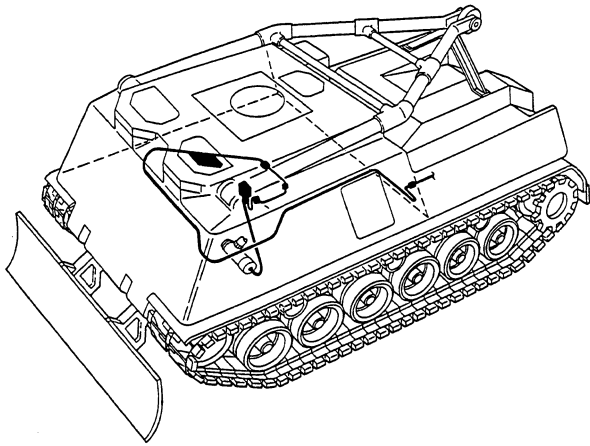

Troubleshooting Procedure

Bilge Pump System and Electrical Accessories Panel Power Outlet

Symptom

Bilge pump system or electrical accessories panel power outlet malfunctioning.

Malfunction

Bilge pump fails to operate. Do steps 1 thru 16.

Bilge pump indicator lamp fails to light and bilge pump operates. Do steps 1 and 2.

Electrical accessories panel power outlet has no power and bilge pump operates. Do step 17.

CORRECTIVE ACTION

WARNING

Remove all jewelry such as rings, dog tags, bracelets, etc. If jewelry contacts a metal surface a direct short may result in instant heating of tools, damage to equipment, and injury or death to personnel.

1. Remove BILGE PUMP indicator lamp. Place red lead of multimeter in socket and black lead to ground. Turn MASTER and BILGE PUMP switches ON and check for voltage. Turn MASTER and BILGE PUMP switches OFF. If voltage is present, replace lamp (see WP 0158 00). If voltage is not present, go to step 2.

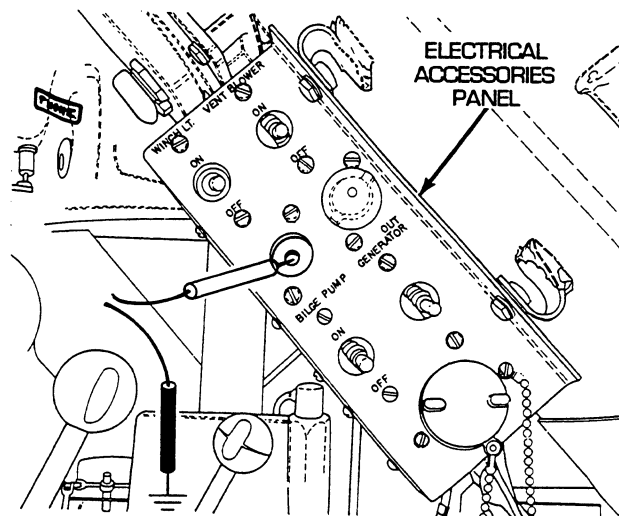

CORRECTIVE ACTION –Continued

2. Remove four screws (1) and four lockwashers (2) and release electrical accessories panel (3). Disconnect wire 450B from BILGE PUMP indicator light. Place red lead of multimeter on wire 450B and black lead to ground. Turn MASTER and BILGE PUMP switches ON and check for voltage. Turn MASTER and BILGE PUMP switches OFF. If voltage is present, replace lamp socket (see WP 0158 00). If voltage is not present, go to step 3.

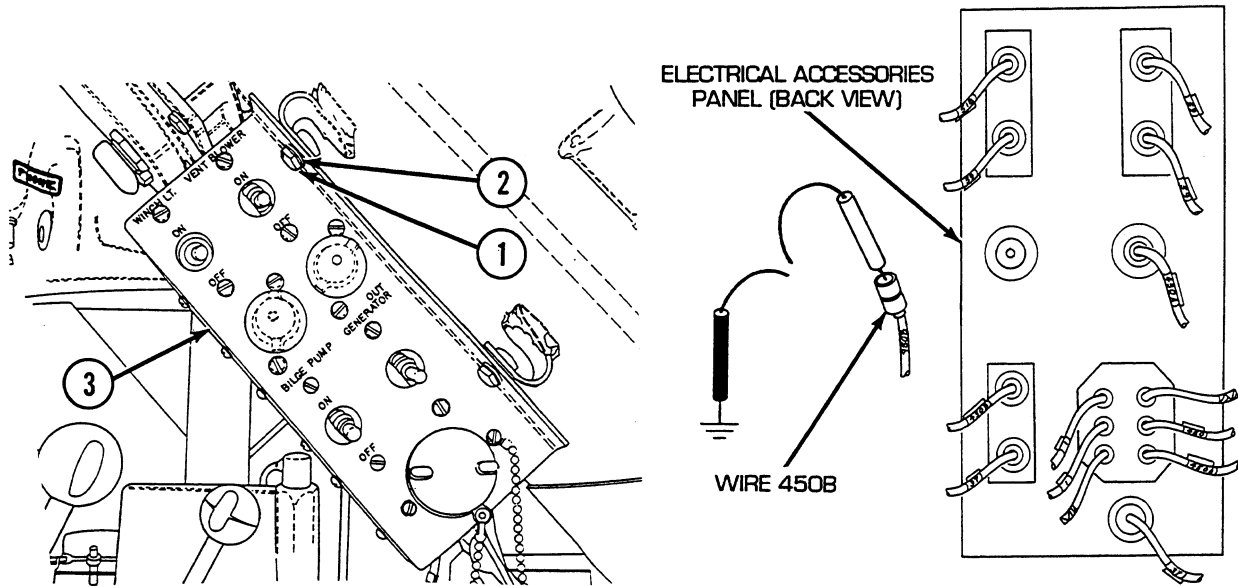

3. Disconnect electrical accessories panel wiring harness from electrical accessories panel. Place red lead of multimeter in socket H of wire 450 and black lead to ground. Turn MASTER switch on and check for voltage. Turn MASTER switch OFF. If voltage is present, go to step 5. If voltage is not present, go to step 4.

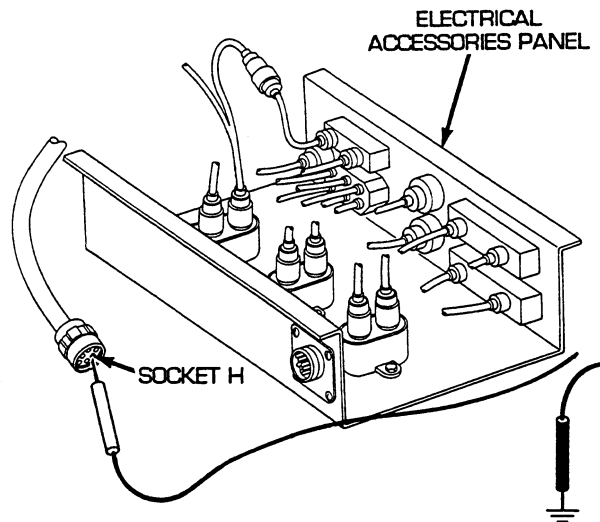

CORRECTIVE ACTION –Continued

4. Reconnect electrical accessories panel wiring harness to electrical accessories panel. Install electrical accessories panel (3), four lockwashers (2), and four screws (1) to mounting bracket. Open air inlet doors (TM 9-2350-256-10). Disconnect wire 48 pin A from bulkhead to master relay wiring harness. Place red multimeter lead in socket and black lead to ground. Turn MASTER switch on and check for voltage. If voltage is present, repair/replace switch panel, radio, and bilge pump to bulkhead wiring harness (see WP 0202 00). If voltage is not present, troubleshoot master relay circuit (see WP 0042 00).

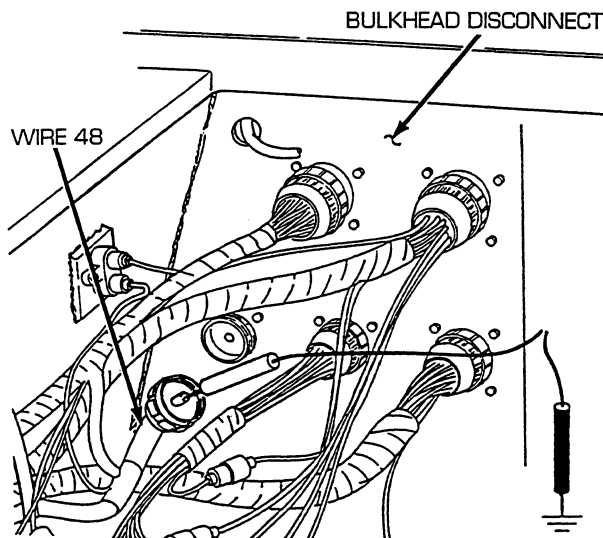

5. Place a jumper wire from pin H to socket H. Place red lead of multimeter on pin E wire 450B of and black lead to ground. Turn MASTER and BILGE PUMP switches ON and check for voltage. Turn MASTER and BILGE PUMP switches OFF. If voltage is present, go to step 12. If voltage is not present, go to step 6.

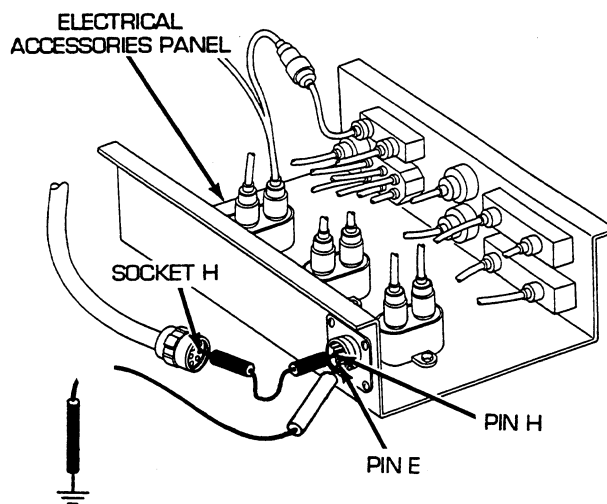

CORRECTIVE ACTION –Continued

6. Disconnect wire 37/450 from panel connector side of circuit breaker. Place red lead of multimeter in wire 37/450 and black lead to ground. Turn MASTER switch on and check for voltage. Turn MASTER switch OFF. If voltage is present, go to step 7. If voltage is not present, repair/replace wire 37/450 of bilge pump main power wiring harness from circuit breaker to connector (see WP 0233 00).

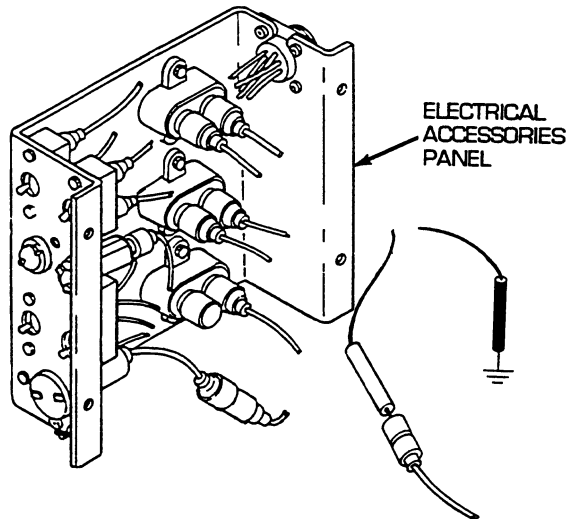

7. Reconnect wire 37/450 to panel connector side of circuit breaker. Disconnect wire 450 from BILGE PUMP switch side of circuit breaker. Place red lead of multimeter on circuit breaker terminal and black lead to ground. Turn MASTER switch on and check for voltage. Turn MASTER switch OFF. If voltage is present, go to step 8. If voltage is not present, replace circuit breaker (see WP 0158 00).

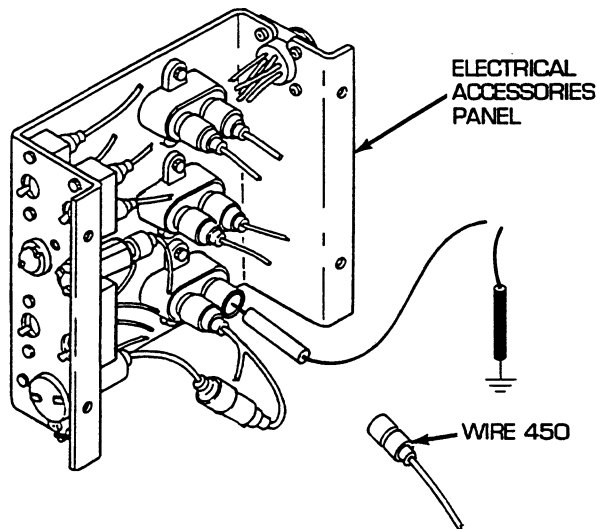

CORRECTIVE ACTION –Continued

8. Reconnect wire 450 to BILGE PUMP switch side of circuit breaker. Disconnect wire 450 from circuit breaker side of BILGE PUMP switch. Place red lead of multimeter in wire 450 and black lead to ground. Turn MASTER switch on and check for voltage. Turn MASTER switch OFF. If voltage is present, go to step 9. If voltage is not present, repair/replace wire 450 from circuit breaker to bilge pump switch (see WP 0233 00).

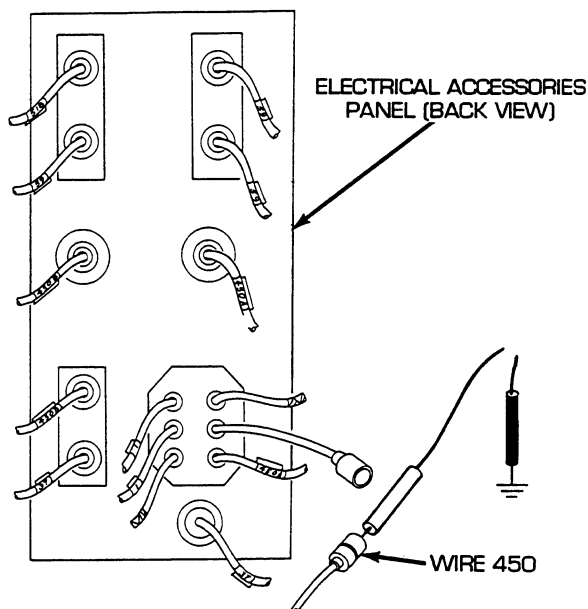

9. Reconnect wire 450 to circuit breaker side of BILGE PUMP switch. Disconnect wire 450B from panel connector side of BILGE PUMP switch. Place red lead of multimeter on BILGE PUMP switch terminal and black lead to ground. Turn MASTER and BILGE PUMP switches ON and check for voltage. Turn MASTER and BILGE PUMP switches OFF. If voltage is present, repair/replace wire 450B of bilge pump main power harness (see WP 0233 00). If voltage is not present, replace BILGE PUMP switch (see WP 0158 00).

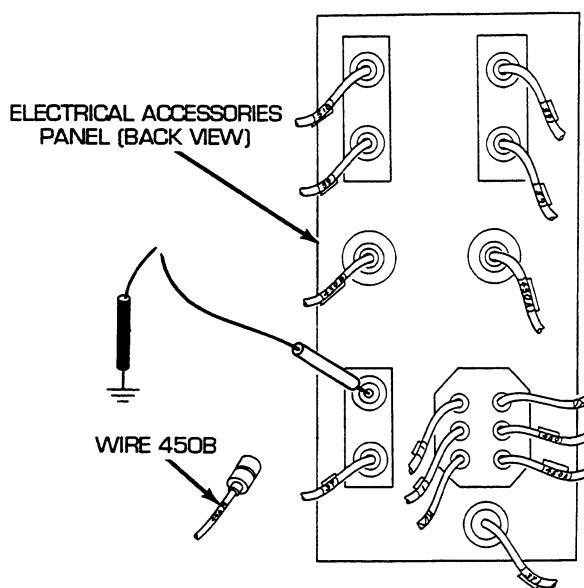

CORRECTIVE ACTION –Continued

10. Reconnect electrical accessories panel wiring harness to electrical accessories panel. Install electrical accessories panel (3), three lockwashers (2), and three screws (1). Open stowage basket forward intermediate left floor plate. Disconnect bilge pump circuit breaker to switch panel lead assembly from bilge pump relay. Place red lead of multimeter in socket A of wire 450B and black lead to ground. Turn MASTER and BILGE PUMP switches ON and check for voltage. Turn MASTER and BILGE PUMP switches OFF. If voltage is present, go to step 12. If voltage is not present, go to step 11.

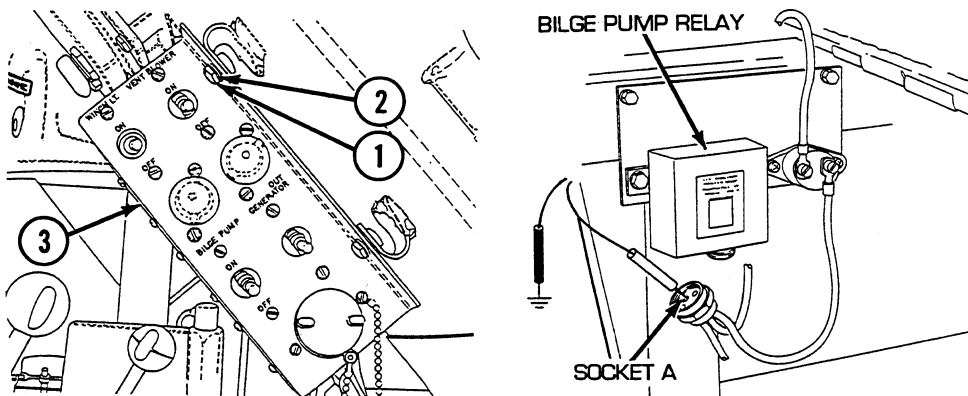

11. Reconnect bilge pump circuit breaker to switch panel lead assembly. Disconnect wire 450B of electrical accessories panel wiring harness from wire 450B of bilge pump lead relay wiring harness. Place red lead of multimeter in female connector of wire 450B and black lead to ground. Turn MASTER and BILGE PUMP switches ON, and check for voltage. Turn MASTER and BILGE PUMP switches OFF. If voltage is not present, repair/replace wire 450B of electrical accessories panel wiring harness (see WP 0196 00). If voltage is present, repair/replace 450B of bilge pump lead relay wiring harness (see WP 0235 00).

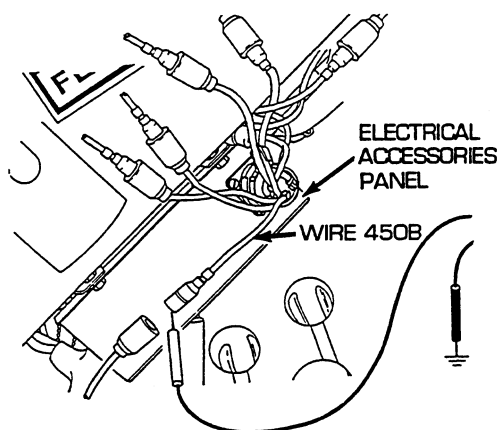

CORRECTIVE ACTION –Continued

12. Place red lead of multimeter in pin B of wire 451A and black lead to ground. Turn MASTER switch on and check for voltage. Turn MASTER switch OFF. If voltage is present, go to step 15. If voltage is not present, go to step 13.

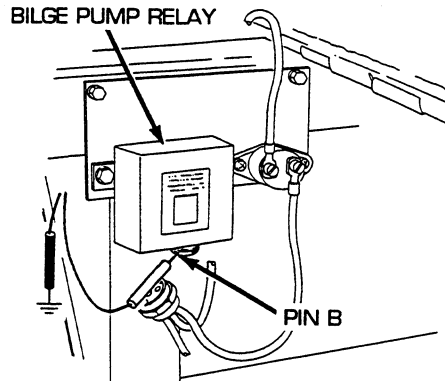

13. Disconnect wire 451A from bilge pump relay side of 50 A circuit breaker. Place red lead of multimeter on 50 A circuit breaker terminal and black lead to ground. Turn MASTER switch on and check for voltage. Turn MASTER switch OFF. If voltage is present, repair/replace wire 451A of bilge pump lead relay wiring harness (see WP 0235 00). If voltage is not present, go to step 14.

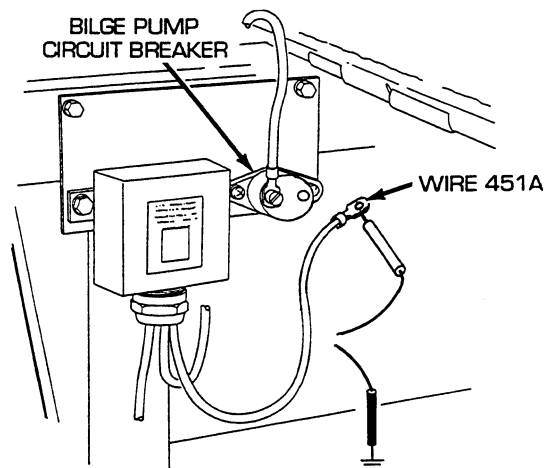

CORRECTIVE ACTION –Continued

14. Reconnect wire 451A to bilge pump relay side of 50 A circuit breaker. Disconnect wire 450A from electrical accessories panel side of 50 A circuit breaker. Place red lead of multimeter in wire 450A and black lead to ground. Turn MASTER switch on and check for voltage. Turn MASTER switch OFF. If voltage is present, replace 50 A circuit breaker (see WP 0234 00). If voltage is not present, repair/replace bilge pump circuit breaker to switch panel lead wire 450A (see WP 0234 00).

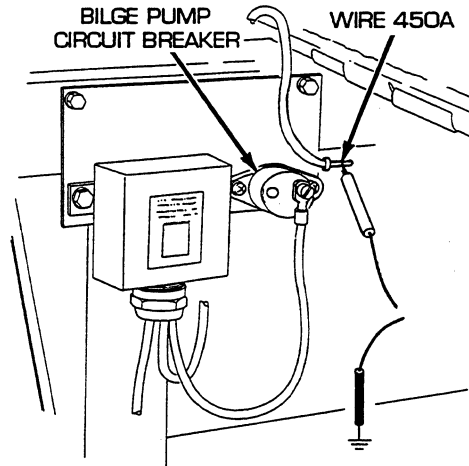

15. Place jumper wires from pin A to socket A and pin B to socket B. Place red lead of multimeter on pin C of wire 451B of bilge pump relay and black lead to ground. Turn MASTER and BILGE PUMP switches ON and check for voltage. Turn MASTER and BILGE PUMP switches OFF. If voltage is present, go to step P. If voltage is not present, repair/replace bilge pump relay (see WP 0250 00).

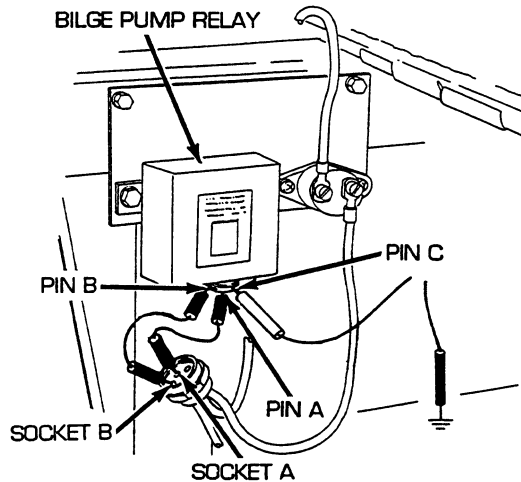

CORRECTIVE ACTION –Continued

16. Reconnect bilge pump circuit breaker to switch panel lead assembly to bilge pump relay. Disconnect wire 451B from bilge pump. Place red lead of multimeter in wire 451B and black lead to ground. Turn MASTER and BILGE PUMP switches ON and check for voltage. Turn MASTER and BILGE PUMP switches OFF. If voltage is present, replace bilge pump assembly (see WP 0473 00). If voltage is not present, repair/replace wire 451B of bilge pump circuit breaker to switch panel lead assembly (see WP 0234 00).

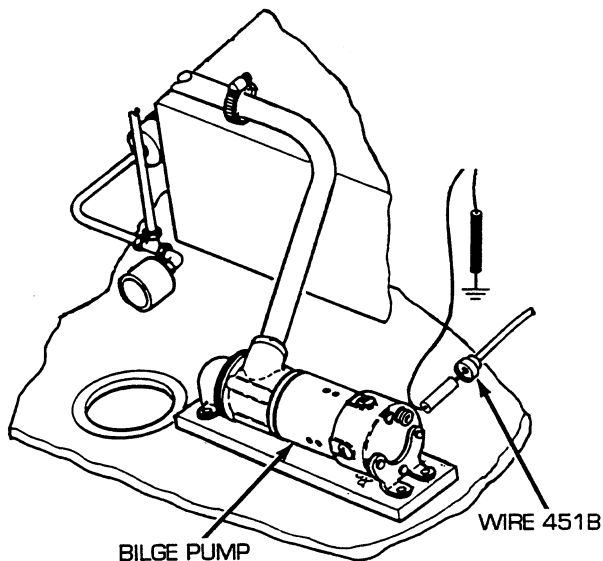

17. Remove four screws (1) and four lockwashers (2) and release electrical accessories panel (3). Disconnect wire 37 from electrical accessories panel power outlet. Place red lead of multimeter on wire 37 and black lead to ground. Turn MASTER and BILGE PUMP switches ON and check for voltage. Turn MASTER and BILGE PUMP switches OFF. If voltage is present, replace electrical accessories panel power outlet (see WP 0158 00). If voltage is not present, repair/replace wire 37 of bilge pump and generator cutout switch lead assembly (see WP 0232 00).

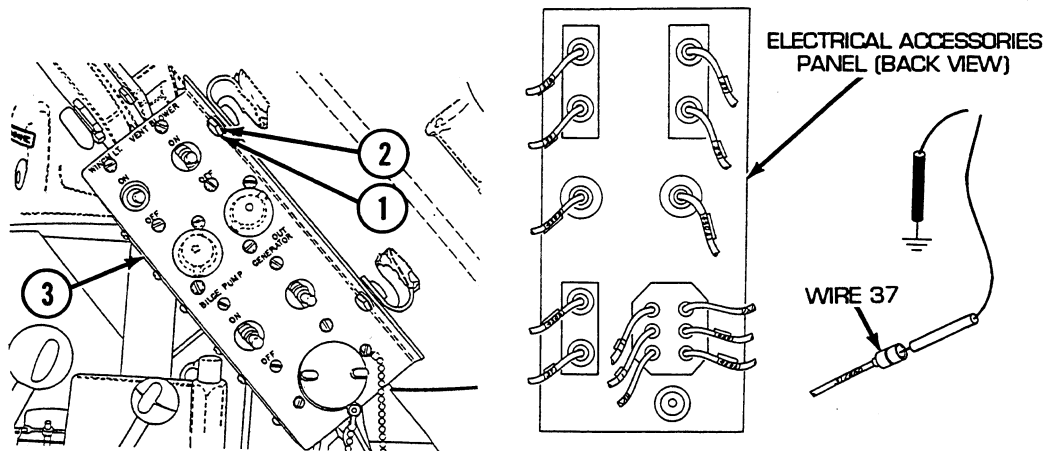

END OF WORK PACKAGE

UNIT MAINTENANCE
RECOVERY VEHICLE, FULL TRACKED: MEDIUM, M88A1
NSN 2350-00-122-6826, EIC AQA

PERSONNEL HEATER CONTROL SYSTEM TROUBLESHOOTING PROCEDURE

INITIAL SETUP:

Tools and Special Tools

Tool kit, general mechanic's (item 59, WP 0490 00)

References

WP 0161 00

WP 0187 00

References (cont.)

WP 0220 00

WP 0236 00

WP 0398 00

TM 9-2540-205-24&P

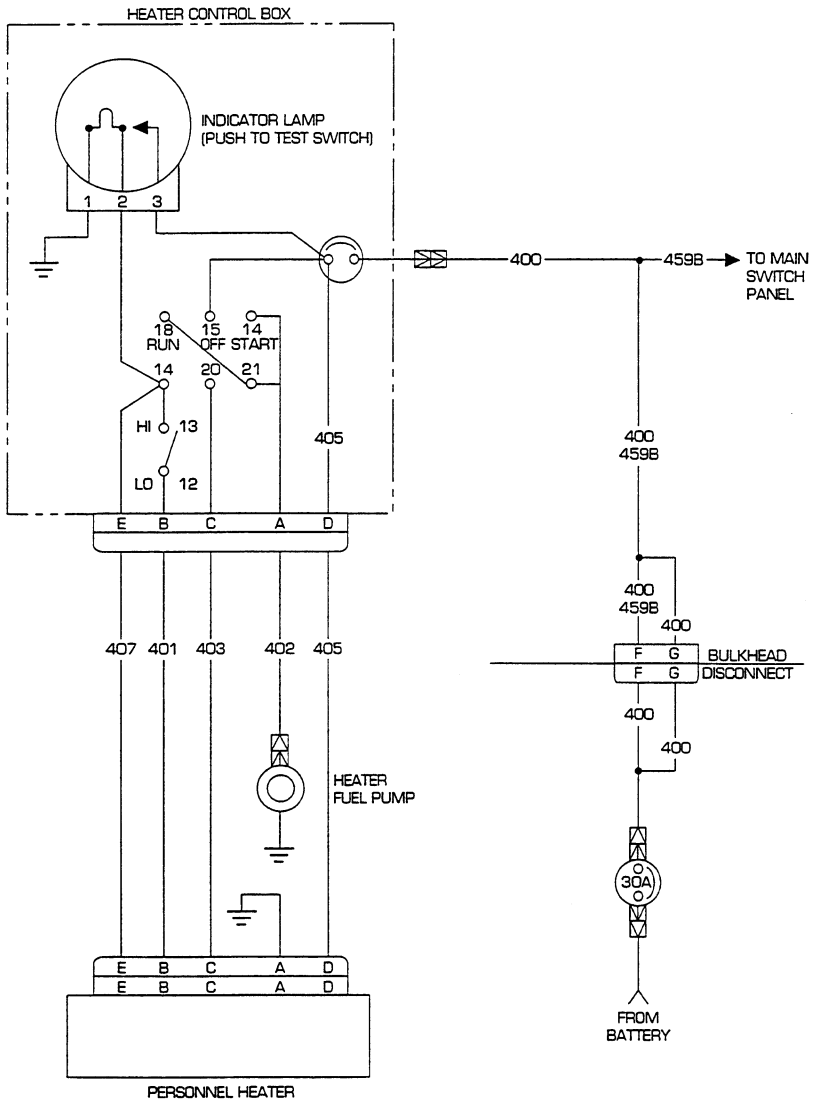
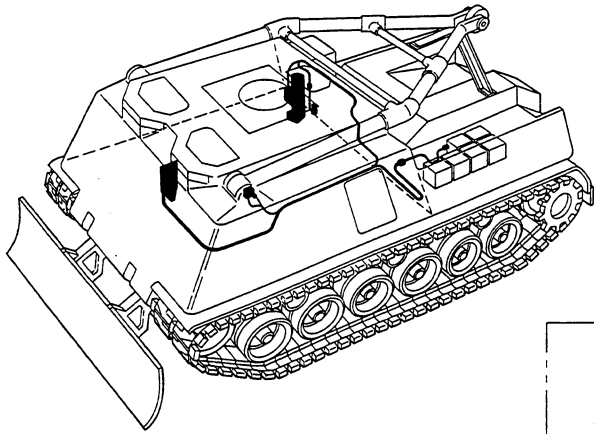

Troubleshooting Procedure**Personnel Heater Control System****Symptom**

Personnel heater control system malfunctioning.

Malfunction

Personnel heater fails to operate. Do steps 1 thru 14.

CORRECTIVE ACTION**WARNING**

Remove all jewelry such as rings, dog tags, bracelets, etc. If jewelry contacts a metal surface a direct short may result in instant heating of tools, damage to equipment, and injury or death to personnel.

1. Disconnect wire 400 of switch panel to head lamps and bulkhead wiring harness from connector at HEATER CONTROL box. Place red lead of multimeter in wire 400 and black lead to ground. Turn MASTER switch on and check for voltage. Turn MASTER switch OFF. If voltage is present, go to step 2. If voltage is not present, go to step 12.

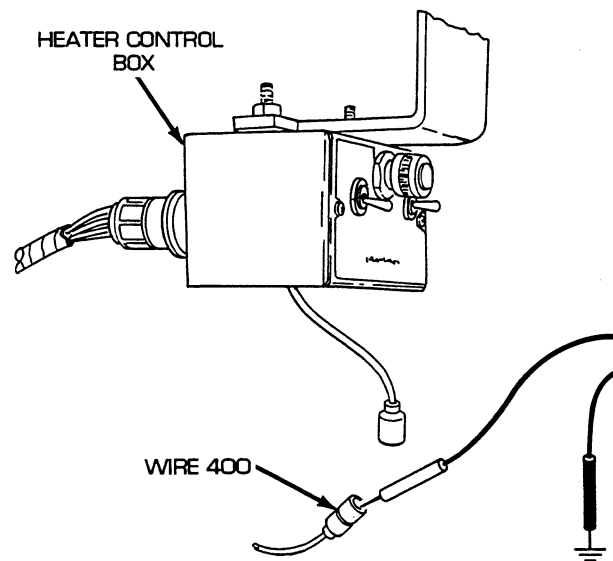

CORRECTIVE ACTION –Continued

2. Reconnect wire 400 of switch panel to head lamps and bulkhead wiring harness to HEATER CONTROL box connector. Remove two screws (1) and release personnel heater control box front panel (2) from personnel heater control box (3). Disconnect heater control box to heater wiring harness from HEATER CONTROL box. Place red lead of multimeter on pin D of wire 405 and black lead to ground. Turn MASTER switch on, HEATER CONTROL switch to START, and check for voltage. Turn MASTER and HEATER CONTROL switches OFF. If voltage is present, go to step 3. If voltage is not present, replace HEATER CONTROL box (see WP 0161 00).

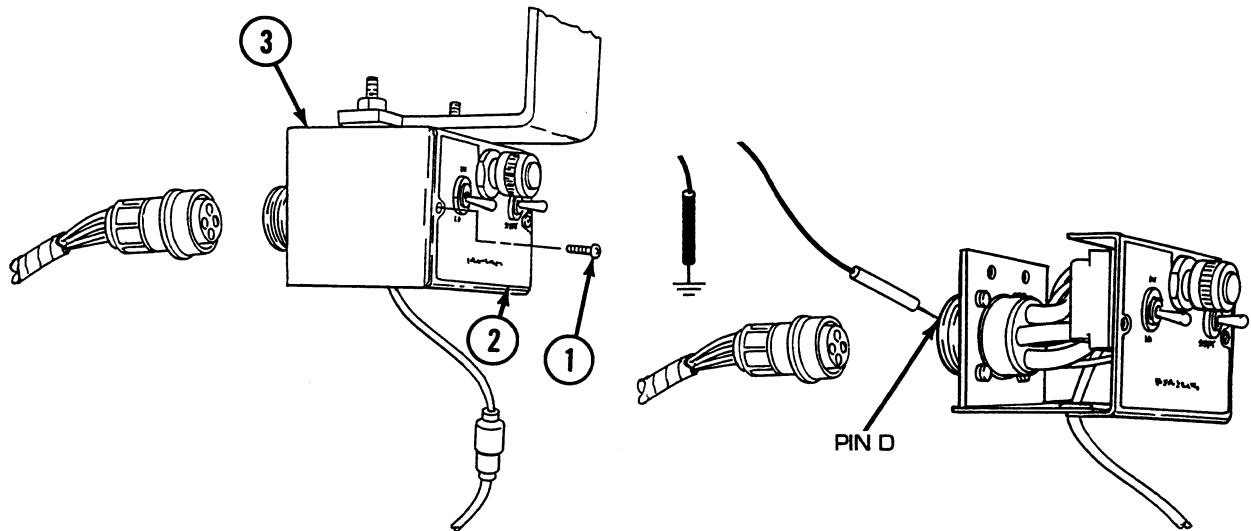

3. Place red lead of multimeter on pin A of wire 402 and black lead to ground. Turn MASTER switch on, HEATER CONTROL switch to START, and check for voltage. Place HEATER CONTROL switch in RUN position and check for voltage. Turn MASTER and HEATER CONTROL switches OFF. If voltage is present, go to step 4. If voltage is not present, replace HEATER CONTROL box (see WP 0161 00).

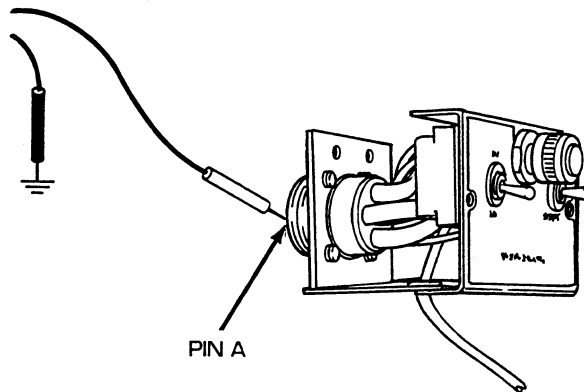

CORRECTIVE ACTION –Continued

4. Place red lead of multimeter on pin C of wire 403 and black lead to ground. Turn MASTER switch on, HEATER CONTROL switch to START, and check for voltage. Place HEATER CONTROL switch in RUN position and check for voltage. Turn MASTER and HEATER CONTROL switches OFF. If voltage is present, go to step 5. If voltage is not present, replace HEATER CONTROL box (see WP 0161 00).

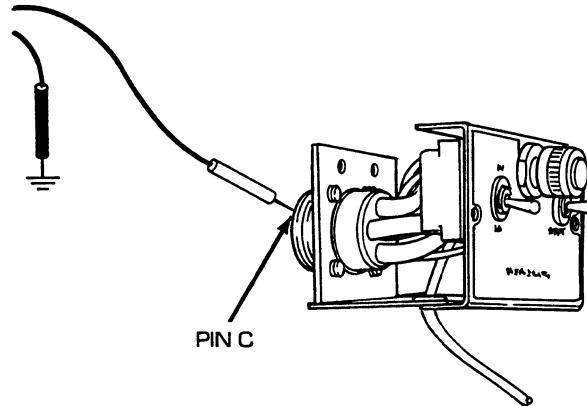

5. Place red lead of multimeter on pin C of wire 403 and black lead on pin E of wire 407. Check for continuity. If continuity is present, go to step 6. If continuity is not present, replace HEATER CONTROL box (see WP 0161 00).

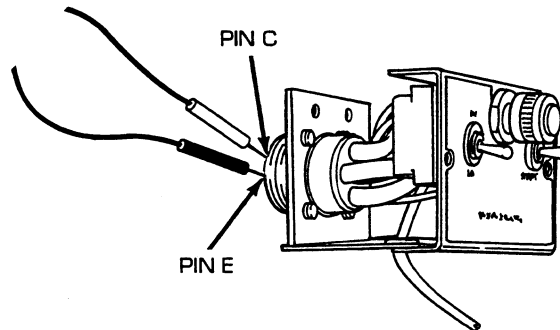

CORRECTIVE ACTION –Continued

6. Reconnect heater control box to heater wiring harness to HEATER CONTROL box. Disconnect HEATER CONTROL box to heater wiring harness from the personnel heater. Place red lead of multimeter in socket E of wire 407 and black lead to ground. Turn MASTER switch on, HEATER CONTROL switch to START, and check for voltage. Turn MASTER and HEATER CONTROL switches OFF. If voltage is present, go to step 6. If voltage is not present, repair/replace wire 407 of heater control box to heater wiring harness (see WP 0236 00).

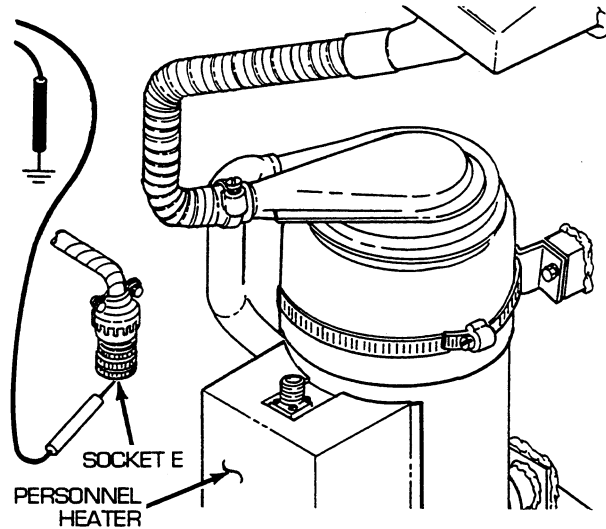

7. Place red lead of multimeter in socket B of wire 401 and black lead to ground. Turn MASTER switch on, HEATER CONTROL switch to START, and check for voltage. Turn MASTER and HEATER CONTROL switches OFF. If voltage is present, go to step 8. If voltage is not present, repair/replace wire 401 of heater control box to heater wiring harness (see WP 0236 00).

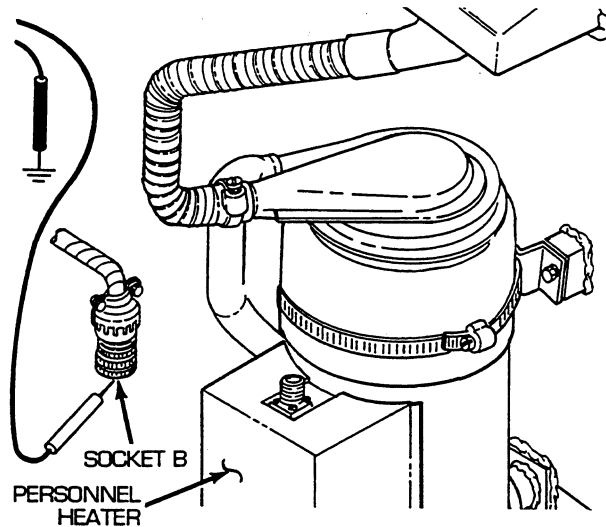

CORRECTIVE ACTION –Continued

8. Place red lead of multimeter in socket C of wire 403 and black lead to ground. Turn MASTER switch on, and HEATER CONTROL switch to START, and check for voltage. Turn MASTER and HEATER CONTROL switches OFF. If voltage is present, go to step 9. If voltage is not present, repair/replace wire 403 of heater control box to heater wiring harness (see WP 0236 00).

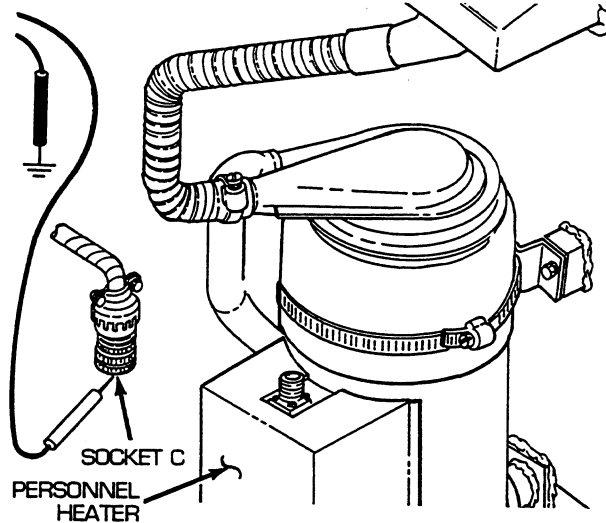

9. Place red lead of multimeter in socket D of wire 405 and black lead to ground. Turn MASTER switch on, HEATER CONTROL switch to START, and check for voltage. Turn MASTER and HEATER CONTROL switches OFF. If voltage is present, go to step 10. If voltage is not present, repair/replace wire 405 of heater control box to heater wiring harness (see WP 0236 00).

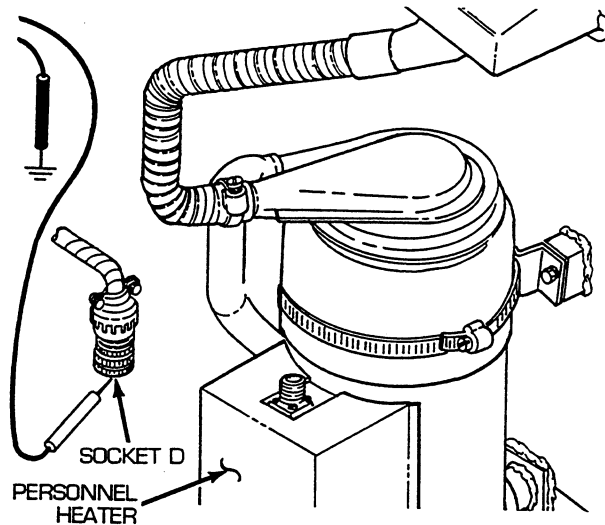

CORRECTIVE ACTION –Continued

10. Reconnect heater control box to heater wiring harness to personnel heater. Disconnect wire 402 from heater fuel pump. Place red lead of multimeter in wire 402 and black lead to ground. Turn MASTER switch on, HEATER CONTROL switch to START, and check for voltage. Turn MASTER and HEATER CONTROL switches OFF. If voltage is present, go to step 11. If voltage is not present, repair/replace wire 402 of heater control box to heater wiring harness (see WP 0236 00).

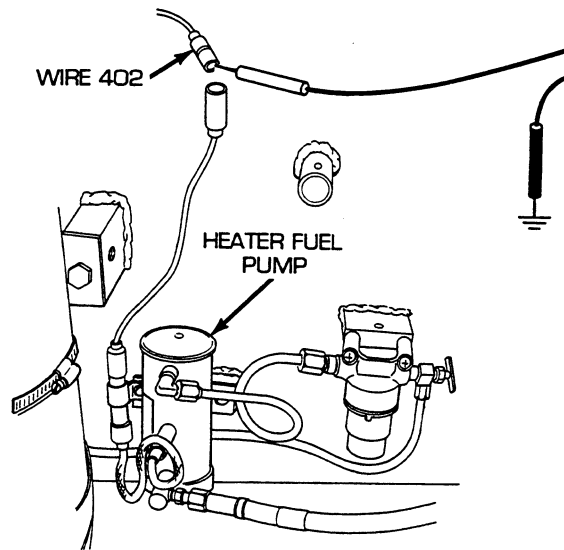

11. Reconnect wire 402 to heater fuel pump. Disconnect fuel line from fuel pump. Turn MASTER switch on, HEATER CONTROL switch to START, and check for fuel flow. Turn MASTER and HEATER CONTROL switches OFF. If fuel flow is present, troubleshoot personnel heater (TM 9-2540-205-24&P). If fuel flow is not present, replace heater fuel pump (see WP 0398 00).

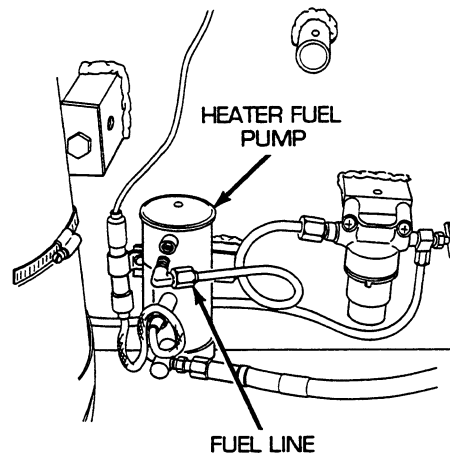

CORRECTIVE ACTION –Continued

12. Reconnect wire 400 of switch panel to head lamps and bulkhead wiring harness to connector at HEATER CONTROL box. Disconnect bulkhead to master relay and left and right taillights wiring harness from bulkhead disconnect. Place red lead of multimeter on pin F of wire 400 and black lead to ground. Turn MASTER switch on and check for voltage. Place red lead of multimeter on pin G of wire 400 and black lead to ground. Check for voltage. Turn MASTER switch OFF. If voltage is not present at either location, repair/replace wire 400 of bulkhead to MASTER relay and left and right taillights wiring harness from bulkhead to battery (see WP 0220 00). If voltage is not present in either location, go to step 13.

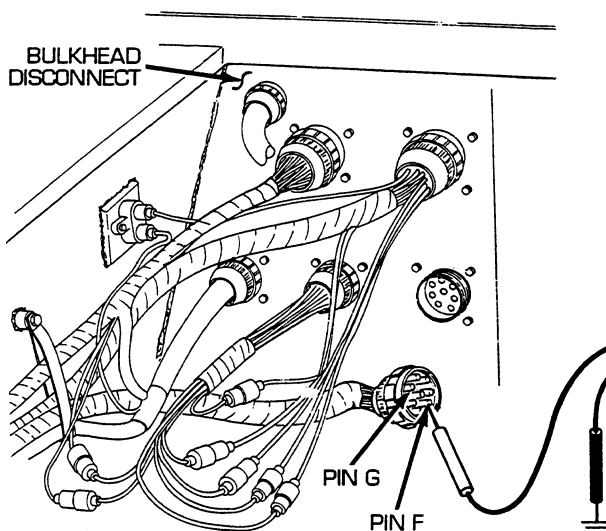

13. Reconnect bulkhead to master relay and left and right taillights wiring harness to bulkhead disconnect. Disconnect wire 400 from bulkhead side of 30 A circuit breaker. Place red lead of multimeter on terminal of circuit breaker and black lead to ground. Turn MASTER switch on and check for voltage. Turn MASTER switch OFF. If voltage is present, repair/replace wire 400 of bulkhead to master relay and left and right taillight wiring harness (see WP 0220 00). If voltage is not present, go to step 14.

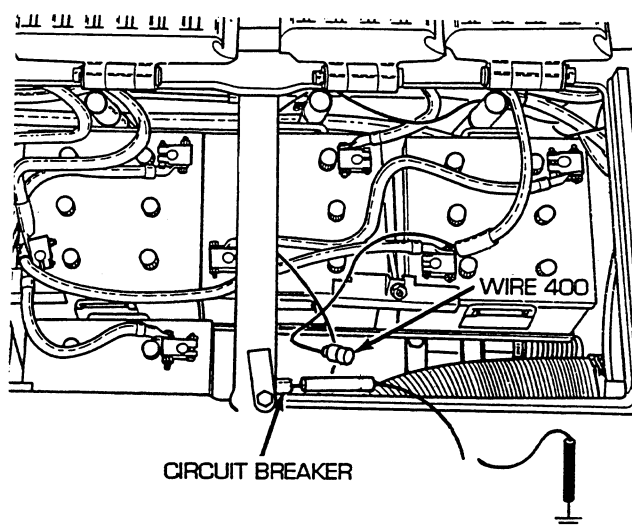

CORRECTIVE ACTION –Continued

14. Reconnect wire 400 to bulkhead side of 30 A circuit breaker. Disconnect wire 400 from battery side of 30 A circuit breaker. Place red lead of multimeter in wire 400 and black lead to ground. Turn MASTER switch on and check for voltage. Turn MASTER switch OFF. If voltage is present, replace 30 A circuit breaker. If voltage is not present, repair/replace wire 400 of battery to circuit breaker lead assembly (see WP 0187 00).

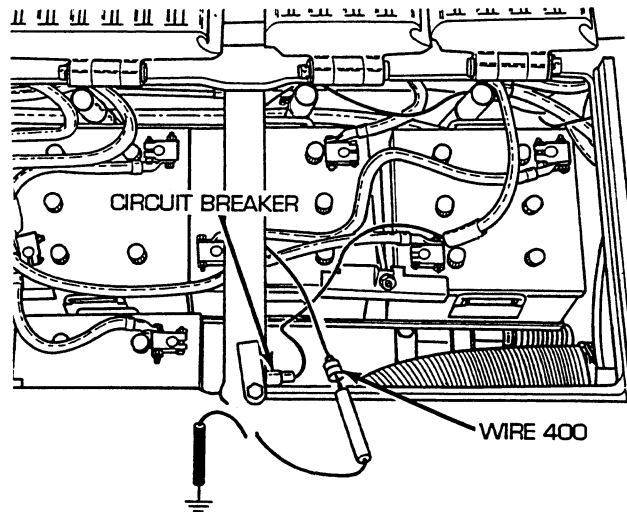
**END OF WORK PACKAGE**

UNIT MAINTENANCE
RECOVERY VEHICLE, FULL TRACKED: MEDIUM, M88A1
NSN 2350-00-122-6826, EIC AQA
COMMUNICATION SYSTEM TROUBLESHOOTING PROCEDURE

INITIAL SETUP:

Tools and Special Tools

Tool kit, general mechanic's (item 59, WP 0490 00)

References

WP 0042 00
WP 0202 00

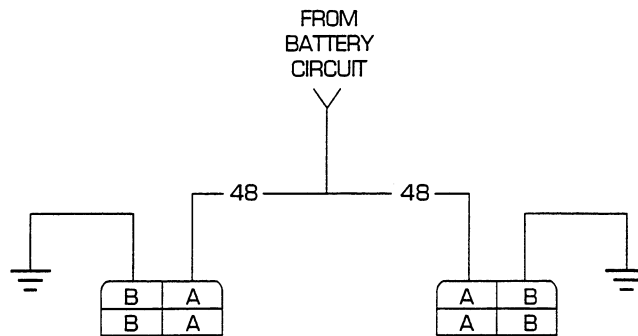
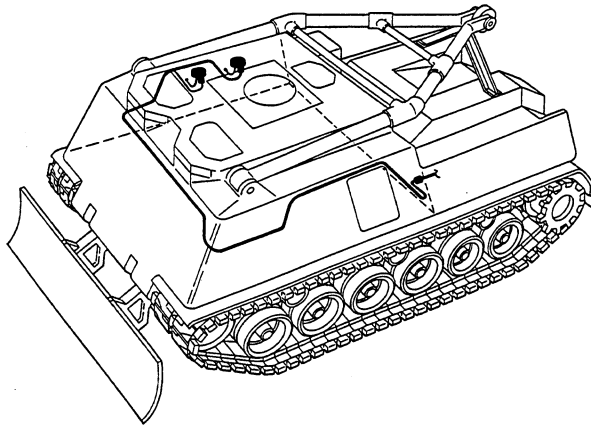

Troubleshooting Procedure

Communication System

Symptom

Communication system malfunctioning.

Malfunction

One radio fails to operate. Do steps 1 thru 3.

CORRECTIVE ACTION

WARNING

Remove all jewelry such as rings, dog tags, bracelets, etc. If jewelry contacts a metal surface a direct short may result in instant heating of tools, damage to equipment, and injury or death to personnel.

1. Disconnect switch panel, radio, and bilge pump to bulkhead wiring harness from both communications systems. Place red lead of multimeter in one socket A of wire 48 and black lead to ground. Turn MASTER switch on and check for voltage. Then place red lead of multimeter in other socket A of wire 48 and black lead to ground and check for voltage. Turn MASTER switch OFF. If voltage is present in both sockets, go to step 2. If voltage is present in one or not present in either, go to step 3.

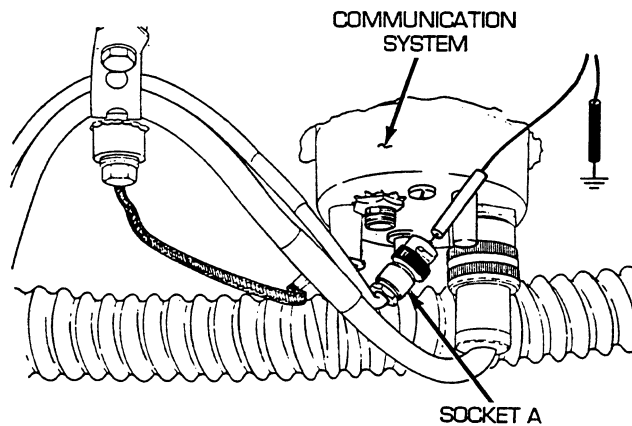

CORRECTIVE ACTION –Continued

2. Disconnect one ground wire from bulkhead. Place red lead of multimeter in socket B of ground wire and black lead on other end of ground wire. Check for continuity. Disconnect other ground wire from bulkhead. Place red lead of multimeter in socket B of ground wire and black lead on other end of ground wire. If continuity is present, troubleshoot master relay (see WP 0042 00). If continuity is not present, repair/replace ground wire of switch panel, radio, and bilge pump to bulkhead wiring harness (see WP 0202 00).

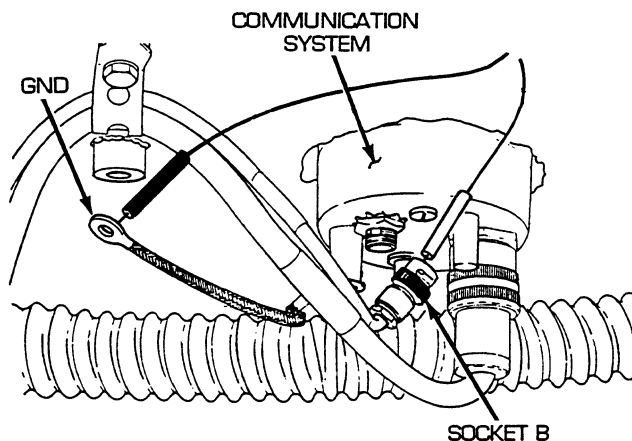

3. Reconnect ground wires to hull and switch panel, radio, and bilge pump to bulkhead wiring harness to both communications systems. Disconnect wire 48 pin A from bulkhead to master relay wiring harness. Place red multimeter lead in socket and black lead to ground. Turn MASTER switch on and check for voltage. Turn MASTER switch OFF. If voltage is present, repair or replace switch panel, radio, and bilge pump to bulkhead wiring harness (see WP 0202 00). If voltage is not present, troubleshoot master relay circuit (see WP 0042 00).

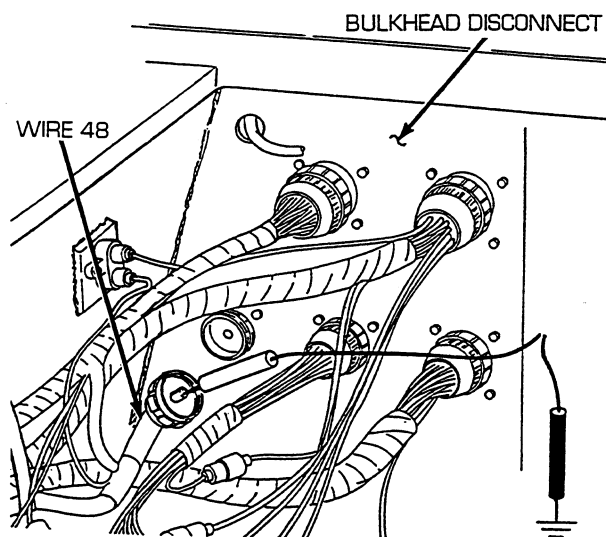

END OF WORK PACKAGE

UNIT MAINTENANCE
RECOVERY VEHICLE, FULL TRACKED: MEDIUM, M88A1
NSN 2350-00-122-6826, EIC AQA
DOMELIGHTS TROUBLESHOOTING PROCEDURE

INITIAL SETUP:**Tools and Special Tools**

Tool kit, general mechanic's (item 59, WP 0490 00)

References

WP 0042 00
WP 0158 00
WP 0159 00
WP 0183 00

References (cont.)

WP 0196 00
WP 0202 00
WP 0204 00
WP 0205 00
WP 0218 00
WP 0233 00
TM 9-2350-256-10

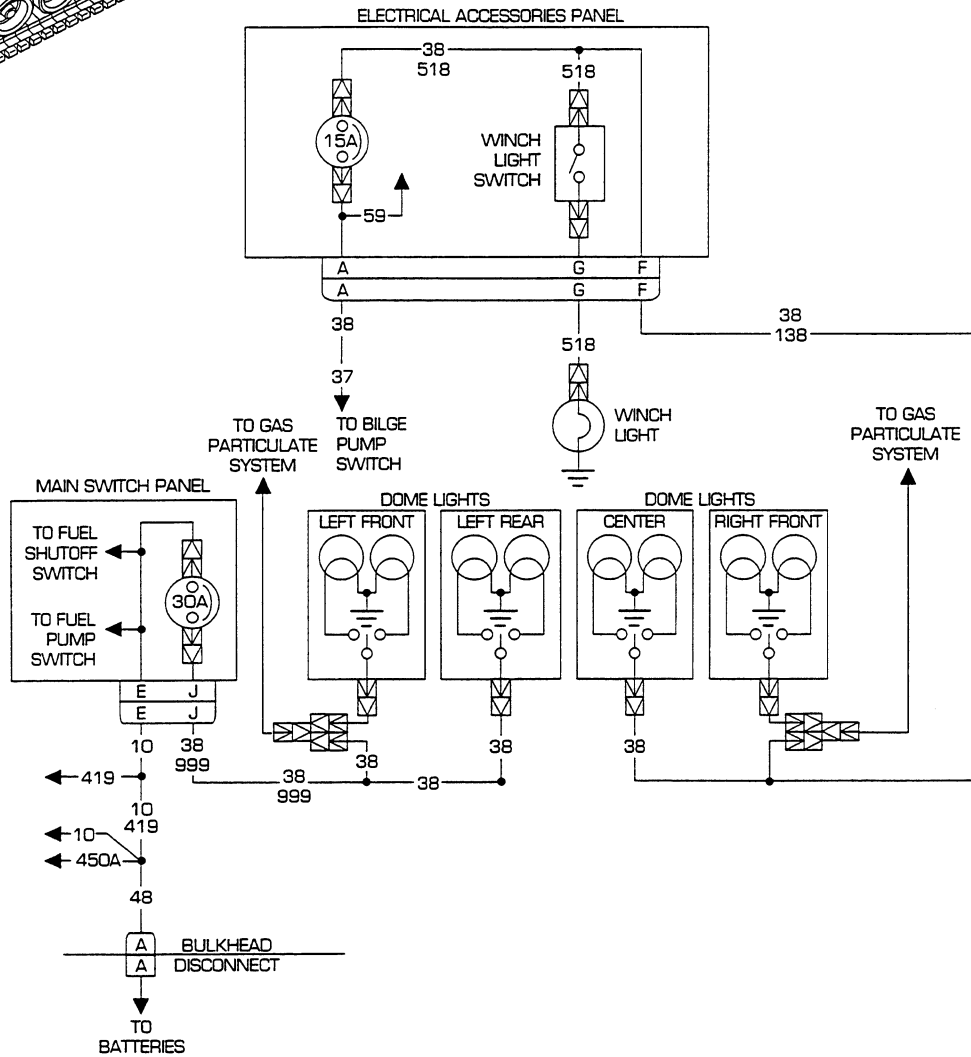
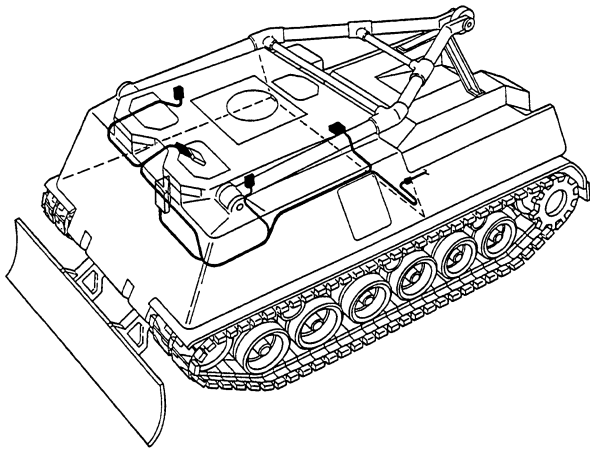

Troubleshooting Procedure

Dome Lights

Symptom

Dome lights malfunctioning.

Malfunction

Both left front and left rear dome lights fail to operate. Do steps 1 thru 6.

Both center and right front dome lights fail to operate. Do steps 1 thru 10.

Only one dome light fails to operate. Do steps 1 and 2.

CORRECTIVE ACTION

WARNING

Remove all jewelry such as rings, dog tags, bracelets, etc. If jewelry contacts a metal surface a direct short may result in instant heating of tools, damage to equipment, and injury or death to personnel.

NOTE

Do steps 1 and 2 for all symptoms.

1. Disconnect wire 38 from dome light. Place red lead of multimeter in wire 38 and black lead to ground. Turn MASTER switch on and check for voltage. Turn MASTER switch OFF. If voltage is present, go to step 2. If voltage is not present, go to step 3 for left front and left rear dome lights and go to step 7 for center and right front dome lights.

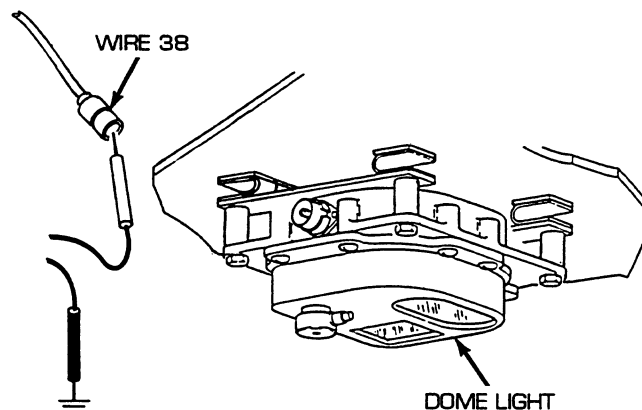

CORRECTIVE ACTION –Continued

2. Remove eight screws (1) and door assembly (2). Remove lamp from socket assembly. Turn MASTER switch on. Place red lead of multimeter on contact in center of socket and black lead to ground. Check for voltage. Turn MASTER switch OFF. If voltage is not present, replace dome light assembly (see WP 0183 00). If voltage is present, replace lamp (see WP 0183 00).

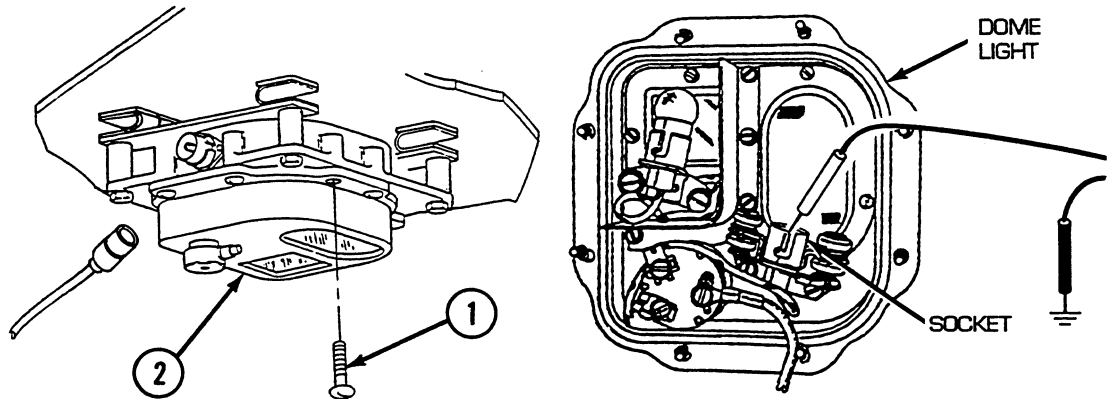

3. Remove three screws (3), three lockwashers (4), ground lead (5), and flat washer (6) and release main switch panel (7) from mounting brackets. Disconnect switch panel to gage panel and miscellaneous switches wiring harness from main switch panel. Place red lead of multimeter on pin E of wire 10 and black lead to ground. Turn MASTER switch on and check for voltage. Turn MASTER switch OFF. If voltage is present, go to step 6. If voltage is not present, reinstall main switch panel and go to step 9.

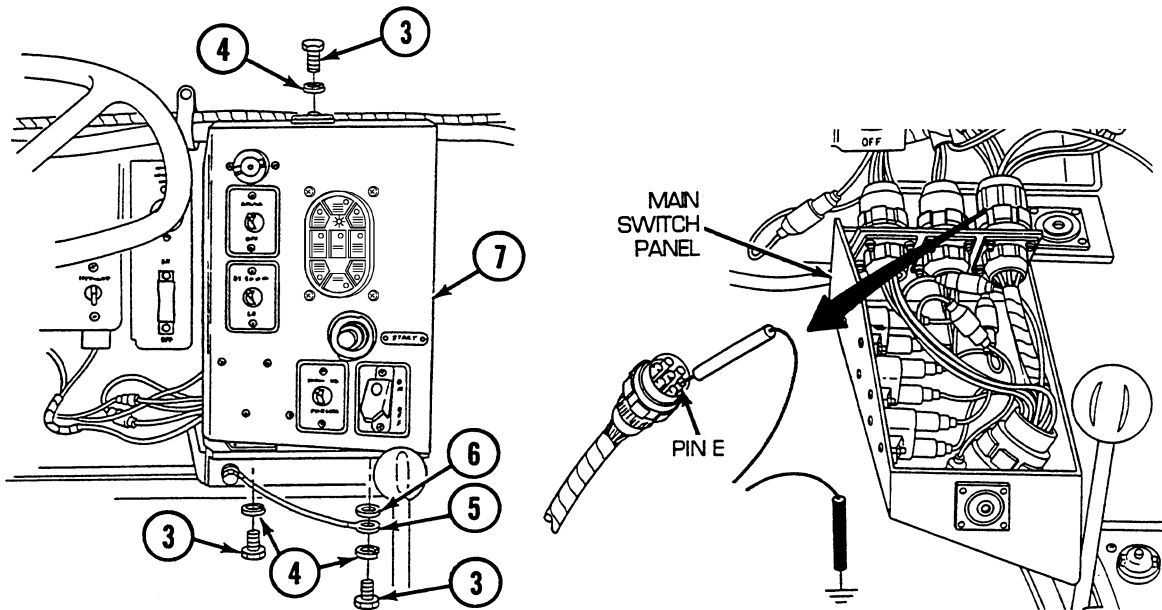

CORRECTIVE ACTION –Continued

4. Place a jumper wire from pin E to socket E of wire 10. Place red lead of multimeter in socket J of wire 38/999 and black lead to ground. Turn MASTER switch on and check for voltage. Turn MASTER switch OFF. If voltage is present, repair/replace wire 38/999 of switch panel to gage panel and miscellaneous switches wiring harness (see WP 0204 00 for dual voltage; 0205 00 for single voltage). If voltage is not present, go to step 5.

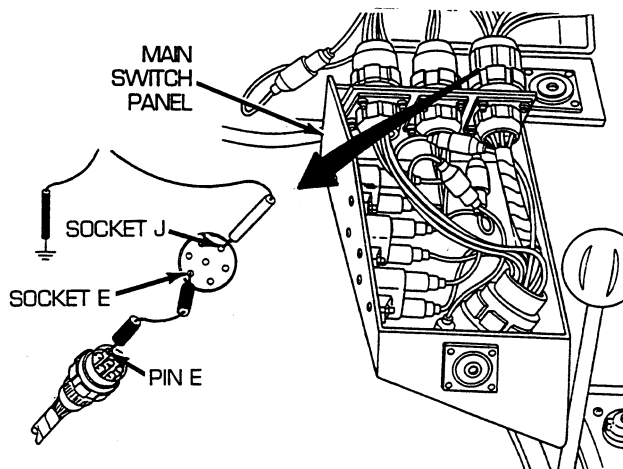

5. Reconnect switch panel to gage panel and miscellaneous switches wiring harness to main switch panel. Remove main switch panel (see WP 0159 00). Place jumper wire from bracket to hull to ground the panel. Disconnect wire 38/999 from 15 A circuit breaker. Place red lead of multimeter on terminal of 15 A circuit breaker and black lead to ground. Turn MASTER switch on and check for voltage. Turn MASTER switch OFF. If voltage is present, repair/replace wire 38/999 of main lighting and B.O. selector switch wiring harness (see WP 0218 00). If voltage is not present, go to step 6.

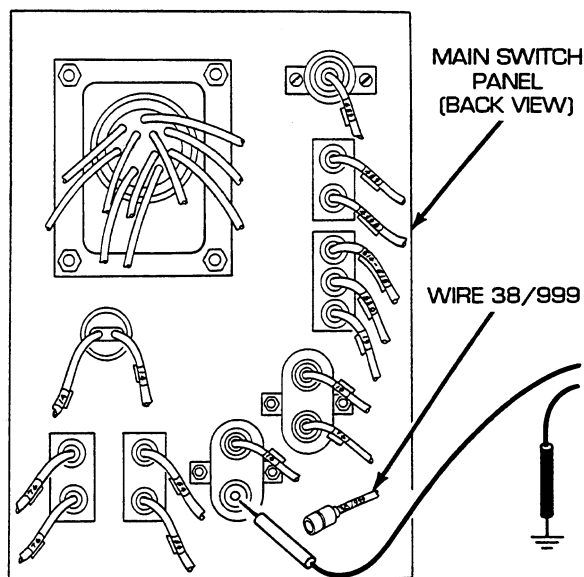

CORRECTIVE ACTION –Continued

6. Reconnect wire 38/999 to 15 A circuit breaker. Disconnect wire 10 from 15 A circuit breaker. Place red lead of multimeter in wire 10 and black lead to ground. Turn MASTER switch on and check for voltage. Turn MASTER switch OFF. If voltage is present, replace 15 A circuit breaker (see WP 0159 00). If voltage is not present, repair/replace wire 10 of main lighting and B.O. selector switch wiring harness (see WP 0218 00).

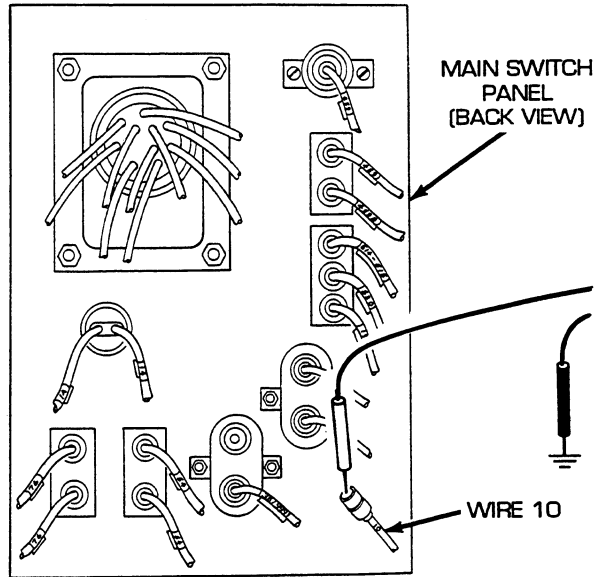

7. Disconnect electrical accessories panel wiring harness from electrical accessories panel. Place a jumper wire from pin A to socket A of wire 38/59. Place red lead of multimeter on pin F of wire 38 and black lead to ground. Turn MASTER switch on and check for voltage. Turn MASTER switch OFF. If voltage is present, repair/replace wire 38 of electrical accessories panel wiring harness (see WP 0196 00). If voltage is not present, go to step 8.

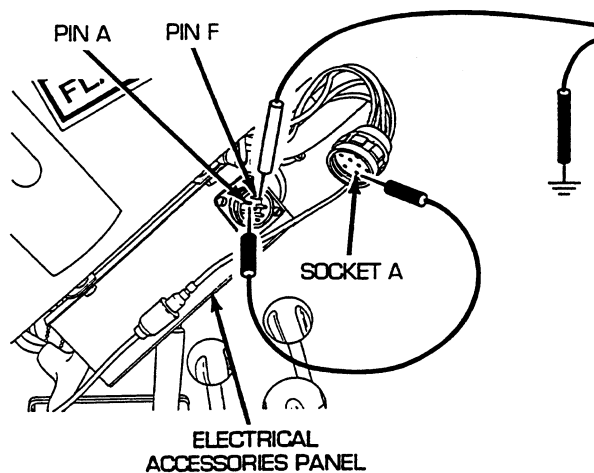

CORRECTIVE ACTION –Continued

8. Place red lead of multimeter in socket A of wire 38/59 and black lead to ground. Turn MASTER switch on and check for voltage. Turn MASTER switch OFF. If voltage is present, go to step 10. If voltage is not present, reconnect electrical accessories panel wiring harness to electrical accessories panel and go to step 9.

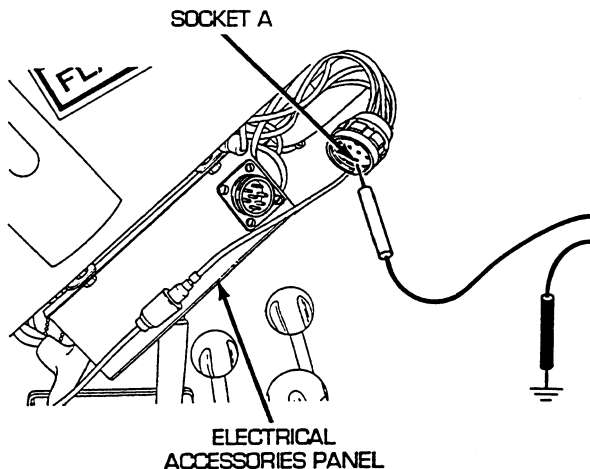

9. Open air inlet doors (TM 9-2350-256-10). Disconnect wire 48 pin A from bulkhead to master relay wiring harness. Place red multimeter lead in socket and black lead to ground. Turn MASTER switch on and check for voltage. If voltage is present, repair/replace switch panel, radio, and bilge pump to bulkhead wiring harness (see WP 0202 00). If voltage is not present, troubleshoot master relay circuit (see WP 0042 00).

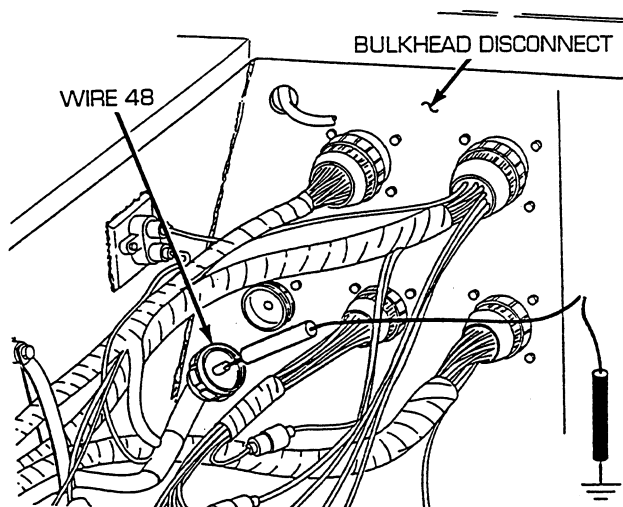

CORRECTIVE ACTION –Continued

10. Remove four screws (8) and four lockwashers (9) and release electrical accessories panel (10). Reconnect electrical accessories panel wiring harness to electrical accessories panel. Disconnect wire 38/518 from winch light switch side of 15 A circuit breaker. Place red lead of multimeter on terminal of 15 A circuit breaker and black lead to ground. Turn MASTER switch on and check for voltage. Turn MASTER switch OFF. If voltage is present, repair/replace wire 38/518 of bilge pump main power wiring harness from 15A circuit breaker to electrical accessories panel wiring harness connector (see WP 0233 00). If voltage is not present, go to step 11.

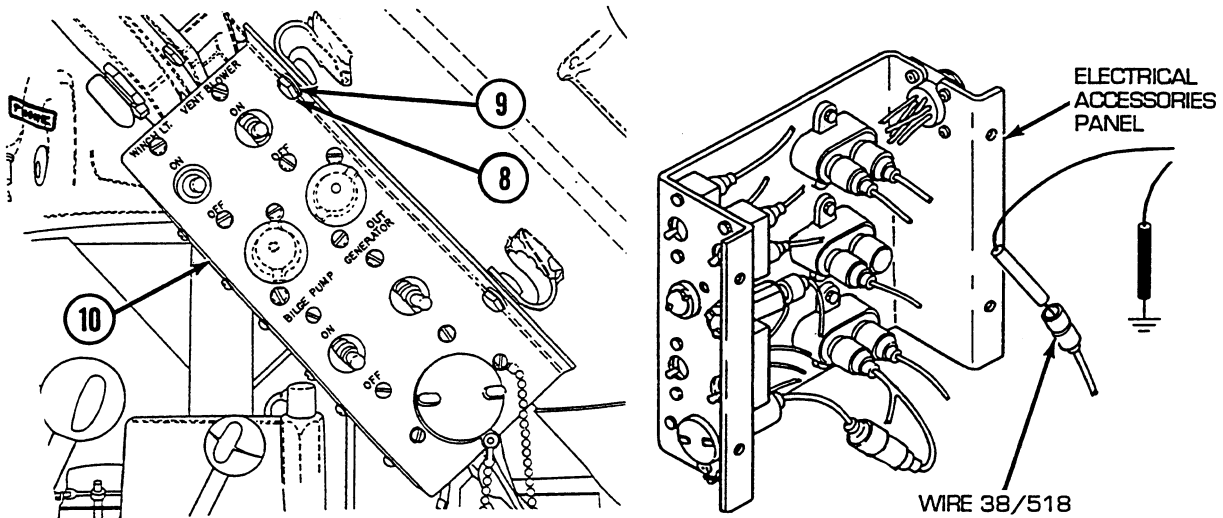

11. Reconnect wire 38/518 to winch light switch side of 15 A circuit breaker. Disconnect wire 38/518 from panel connector side of 15 A circuit breaker. Place red lead of multimeter in wire 38/518 and black lead to ground. Turn MASTER switch on and check for voltage. Turn MASTER switch OFF. If voltage is present, replace 15 A circuit breaker (see WP 0158 00). If voltage is not present, repair/replace wire 38 from pin A to 15 A circuit breaker (see WP 0158 00).

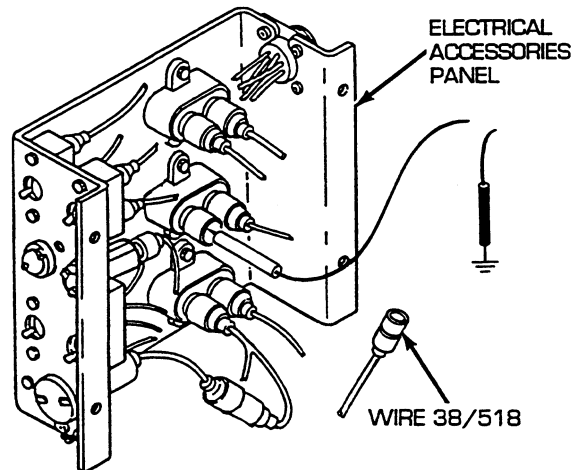

END OF WORK PACKAGE

UNIT MAINTENANCE
RECOVERY VEHICLE, FULL TRACKED: MEDIUM, M88A1
NSN 2350-00-122-6826, EIC AQA
PASSIVE NIGHT VIEWER TROUBLESHOOTING PROCEDURE

INITIAL SETUP:

Tools and Special Tools

Tool kit, general mechanic's (item 59, WP 0490 00)

References

WP 0164 00
WP 0178 00
WP 0204 00

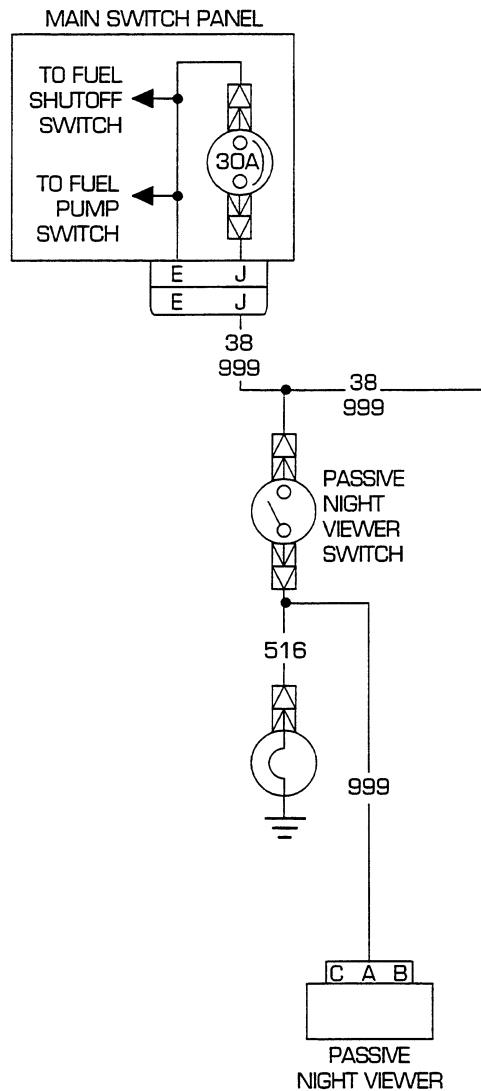
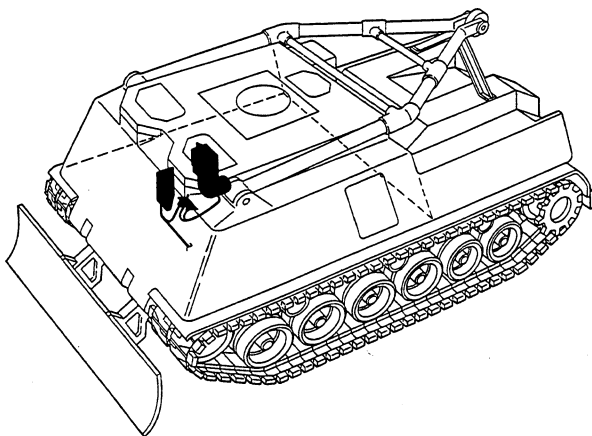

Troubleshooting Procedure

Passive Night Viewer

Symptom

Passive night viewer malfunctioning.

Malfunction

Passive night viewer lamp fails to light but passive night viewer operates. Do step 1.

Passive night viewer fails to operate. Do steps 3 thru 6.

Both lamp and passive night viewer fail to operate. Do steps 5 and 6.

CORRECTIVE ACTION

WARNING

Remove all jewelry such as rings, dog tags, bracelets, etc. If jewelry contacts a metal surface a direct short may result in instant heating of tools, damage to equipment, and injury or death to personnel.

1. Remove night viewer indicator lamp from socket. Place red lead of multimeter in socket and black lead to ground. Turn MASTER switch on and check for voltage. Turn MASTER switch OFF. If voltage is present, replace lamp (see WP 0164 00). If voltage is not present, go to step 2.

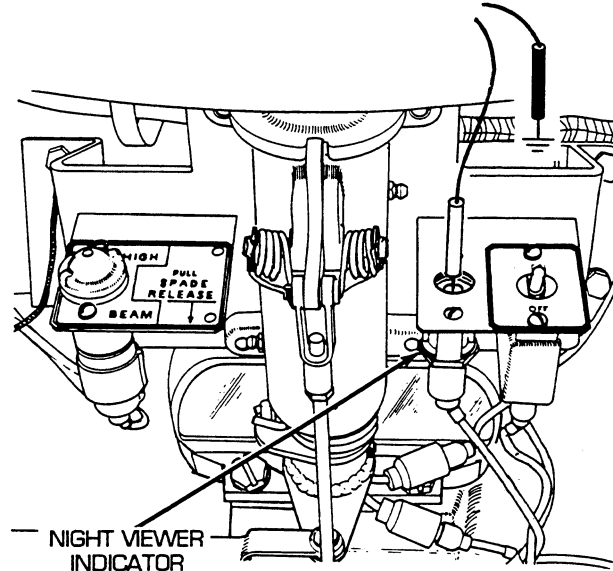

2. Disconnect wire 516 from night viewer indicator lamp. Place red lead of multimeter in wire 516 and check for voltage. If voltage is present replace lamp socket (see WP 0178 00). If voltage is not present, repair/replace wire 999 of switch panel to gage panel and miscellaneous switches wiring harness (see WP 0204 00).

CORRECTIVE ACTION –Continued

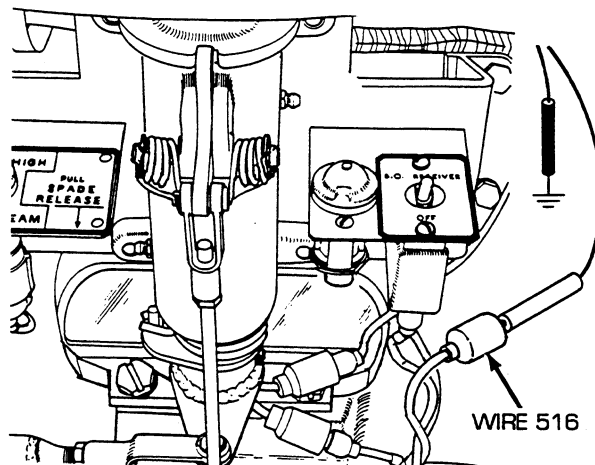

3. Remove switch panel to gage panel and miscellaneous switches wiring harness from passive night viewer. Place red lead of multimeter in socket A of wire 999 and black lead to ground. Turn MASTER and passive NIGHT VIEWER switches on and check for voltage. Turn MASTER and passive NIGHT VIEWER switches OFF. If voltage is present, go to step 4. If voltage is not present, go to step 5.

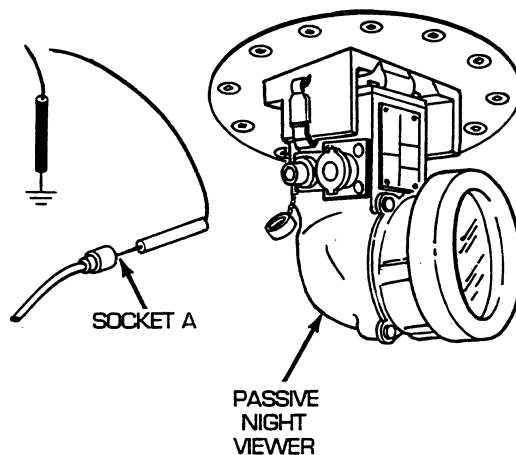

4. Disconnect ground wire from vehicle. Place red lead of multimeter in socket B and black lead on other end of ground wire. Check for continuity. If continuity is not present, repair/replace ground wire of switch panel to gage panel and miscellaneous switches wiring harness (see WP 0204 00). If continuity is present, notify Direct Support Maintenance.

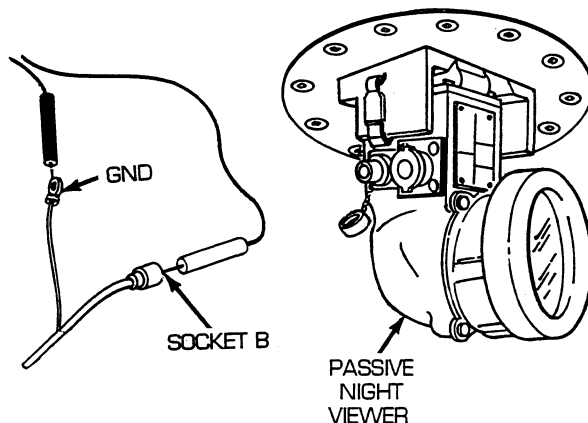

CORRECTIVE ACTION –Continued

5. Disconnect wire 999 from passive night viewer side of passive NIGHT VIEWER switch. Place red lead of multimeter on switch terminal and black lead to ground. Turn MASTER and passive NIGHT VIEWER switches on and check for voltage. Turn MASTER and passive NIGHT VIEWER switches OFF. If voltage is present, repair/replace wire 999 of switch panel to gage panel and miscellaneous switches wiring harness from passive night viewer to passive night viewer switch (see WP 0204 00). If voltage is not present, go to step 6.

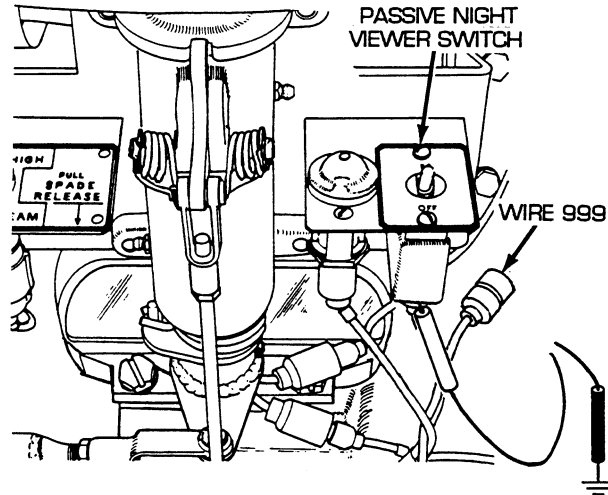

6. Reconnect wire 999 to passive NIGHT VIEWER switch. Disconnect wire 999 from main switch panel side of passive NIGHT VIEWER switch. Place red lead of multimeter in wire 999 and black lead to ground. Turn MASTER switch on and check for voltage. Turn MASTER switch OFF. If voltage is present, replace passive NIGHT VIEWER switch (see WP 0164 00). If voltage is not present, troubleshoot dome light circuit.

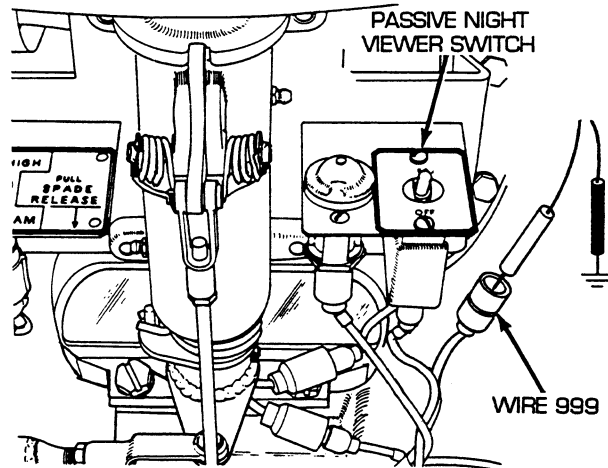

END OF WORK PACKAGE

UNIT MAINTENANCE
RECOVERY VEHICLE, FULL TRACKED: MEDIUM, M88A1
NSN 2350-00-122-6826, EIC AQA
DRIVER'S PERISCOPE TROUBLESHOOTING PROCEDURE

INITIAL SETUP:

Tools and Special Tools

Tool kit, general mechanic's (item 59, WP 0490 00)

References

WP 0164 00

References (cont.)

WP 0178 00

WP 0188 00

WP 0205 00

WP 0249 00

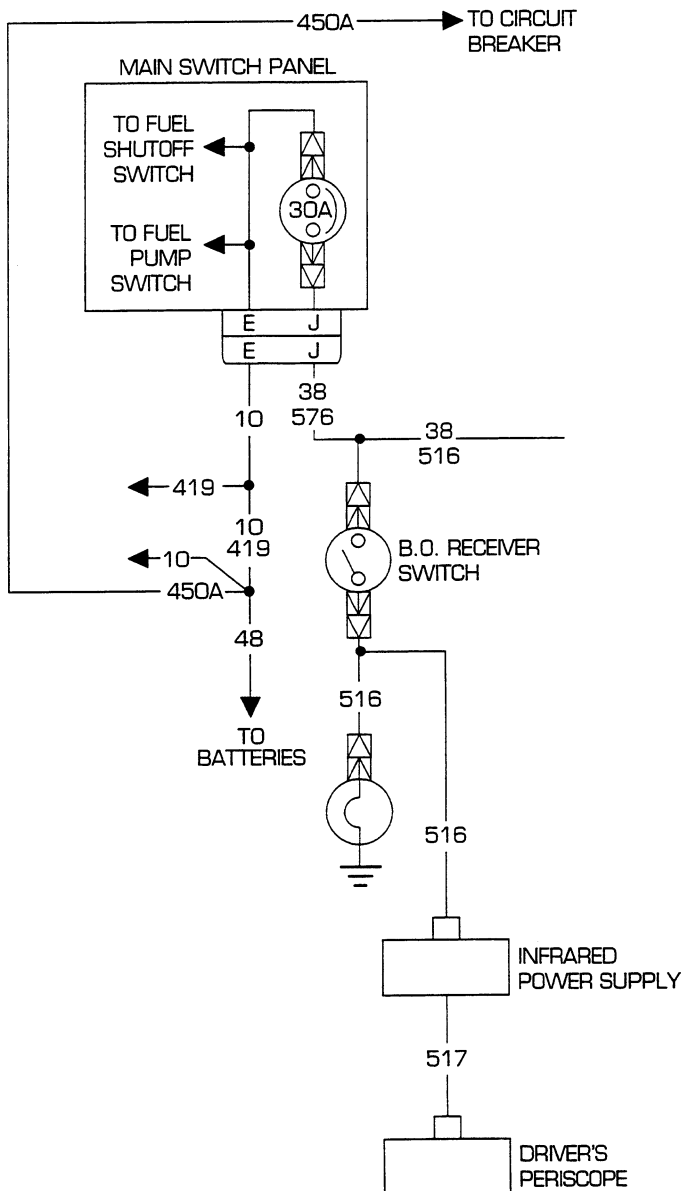
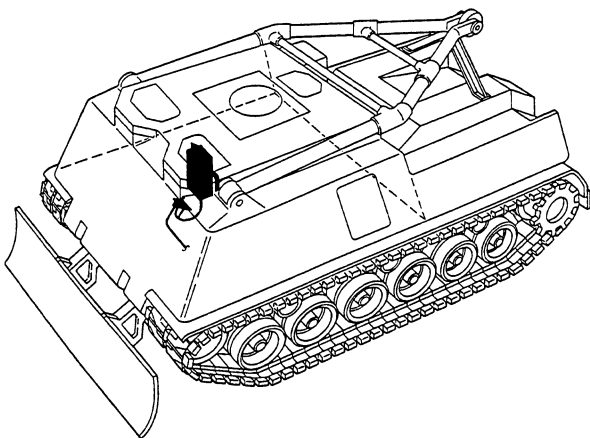

Troubleshooting Procedure

Driver's Periscope

Symptom

Driver's periscope malfunctioning.

Malfunction

B.O. receiver lamp fails to light but driver's periscope operates. Do step 1.

Driver's periscope fails to operate. Do steps 3 thru 7.

Both lamp and driver's periscope fail to operate. Do steps 6 thru 7.

CORRECTIVE ACTION

WARNING

Remove all jewelry such as rings, dog tags, bracelets, etc. If jewelry contacts a metal surface a direct short may result in instant heating of tools, damage to equipment, and injury or death to personnel.

1. Remove B.O. receiver indicator lamp from socket. Place red lead of multimeter in socket and black lead to ground. Turn MASTER switch on and check for voltage. Turn MASTER switch OFF. If voltage is present, replace lamp (see WP 0164 00). If voltage is not present, go to step 2.

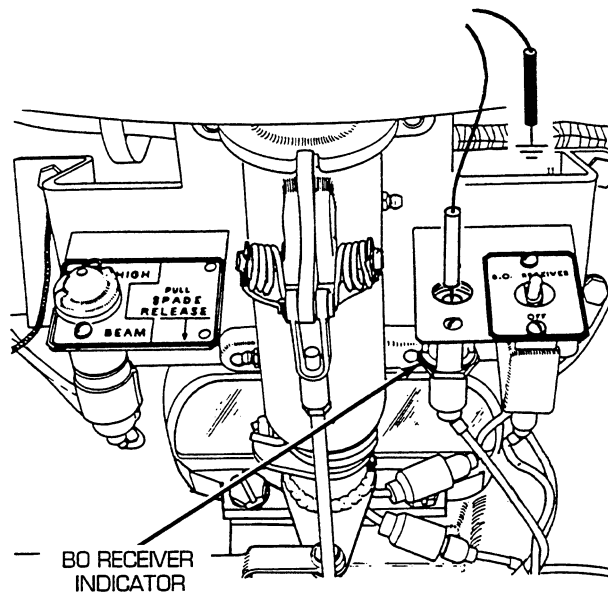

CORRECTIVE ACTION –Continued

2. Disconnect wire 516 from B.O. receiver lamp. Place red lead of multimeter in wire 516 and check for voltage. If voltage is present, replace lamp socket (see WP 0178 00). If voltage is not present, repair/replace wire 516 of switch panel to gage panel and miscellaneous switches wiring harness (see WP 0205 00).

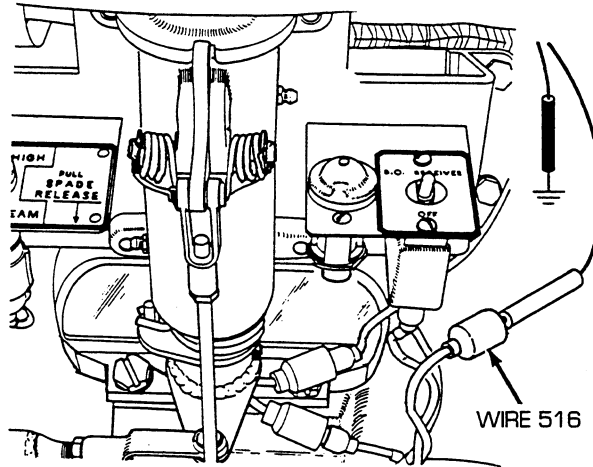

3. Remove infrared power supply to driver's periscope lead assembly from driver's periscope. Place red lead of multimeter in wire 517 and black lead to ground. Turn MASTER and B.O. RECEIVER switches on and check for voltage. Turn MASTER and B.O. RECEIVER switches OFF. If voltage is present, notify Direct Support Maintenance. If voltage is not present, go to step 4.

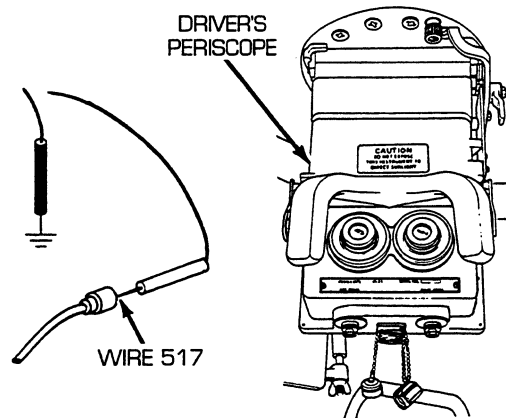

CORRECTIVE ACTION –Continued

4. Disconnect infrared power supply to driver's periscope lead assembly from infrared power supply. Place red lead of multimeter in socket of wire 517 and black lead to ground. Turn MASTER and B.O. RECEIVER switches on and check for voltage. Turn MASTER and B.O. RECEIVER switches OFF. If voltage is present, replace/repair infrared power supply to driver's periscope lead assembly (see WP 0249 00). If voltage is not present, go to step 5.

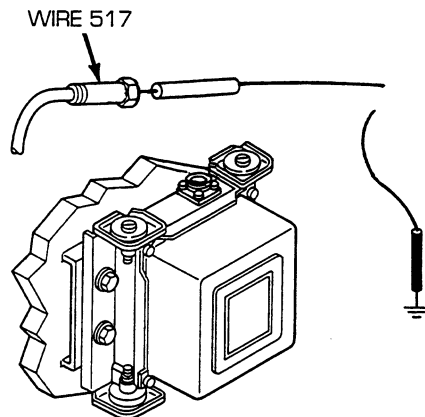

5. Disconnect switch panel to gage panel and miscellaneous switches wiring harness from infrared power supply. Place red lead of multimeter in wire 516 and black lead to ground. Turn MASTER and B.O. RECEIVER switches on and check for voltage. Turn MASTER and B.O. RECEIVER switches OFF. If voltage is present, replace/repair infrared power supply (see WP 0188 00). If voltage is not present, go to step 6.

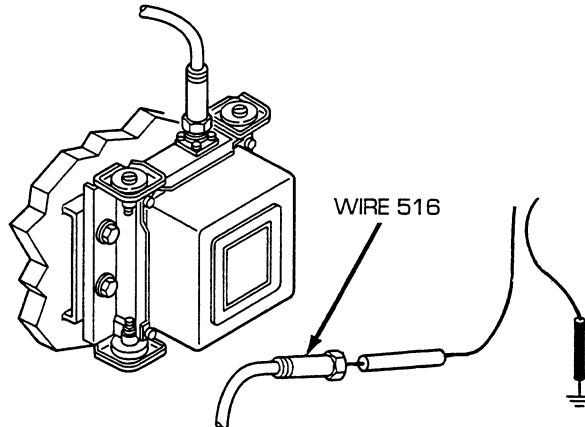

CORRECTIVE ACTION –Continued

6. Disconnect wire 999 from infrared power supply side of B.O. RECEIVER switch. Place red lead of multimeter on switch terminal and black lead to ground. Turn MASTER and B.O. RECEIVER switches on and check for voltage. Turn MASTER and B.O. RECEIVER switches OFF. If voltage is present, repair/replace infrared power supply to B.O. RECEIVER switch wire 999 of switch panel to gage panel and miscellaneous switches wiring harness (see WP 0205 00). If voltage is not present, go to step 7.

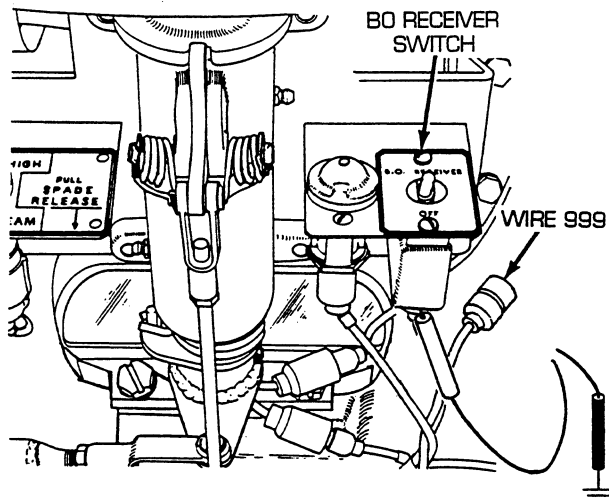

7. Reconnect wire 999 to B.O. RECEIVER switch. Disconnect wire 516 from main switch panel side of B.O. RECEIVER switch. Place red lead of multimeter in wire 516 and black lead to ground. Turn MASTER switch on and check for voltage. Turn MASTER switch OFF. If voltage is present, replace B.O. RECEIVER switch (see WP 0164 00). If voltage is not present, troubleshoot dome light circuit.

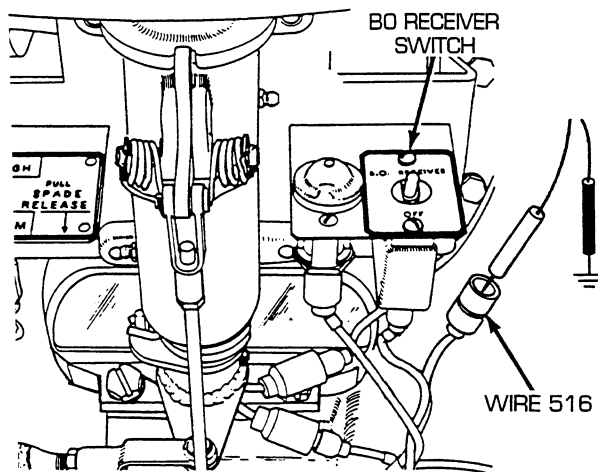

END OF WORK PACKAGE

UNIT MAINTENANCE
RECOVERY VEHICLE, FULL TRACKED: MEDIUM, M88A1
NSN 2350-00-122-6826, EIC AQA
FIXED SPOTLIGHT TROUBLESHOOTING PROCEDURE

INITIAL SETUP:**Tools and Special Tools**

Tool kit, general mechanic's (item 59, WP 0490 00)

References

WP 0042 00
WP 0158 00

References (cont.)

WP 0181 00
WP 0196 00
WP 0202 00
WP 0233 00
TM 9-2350-256-10

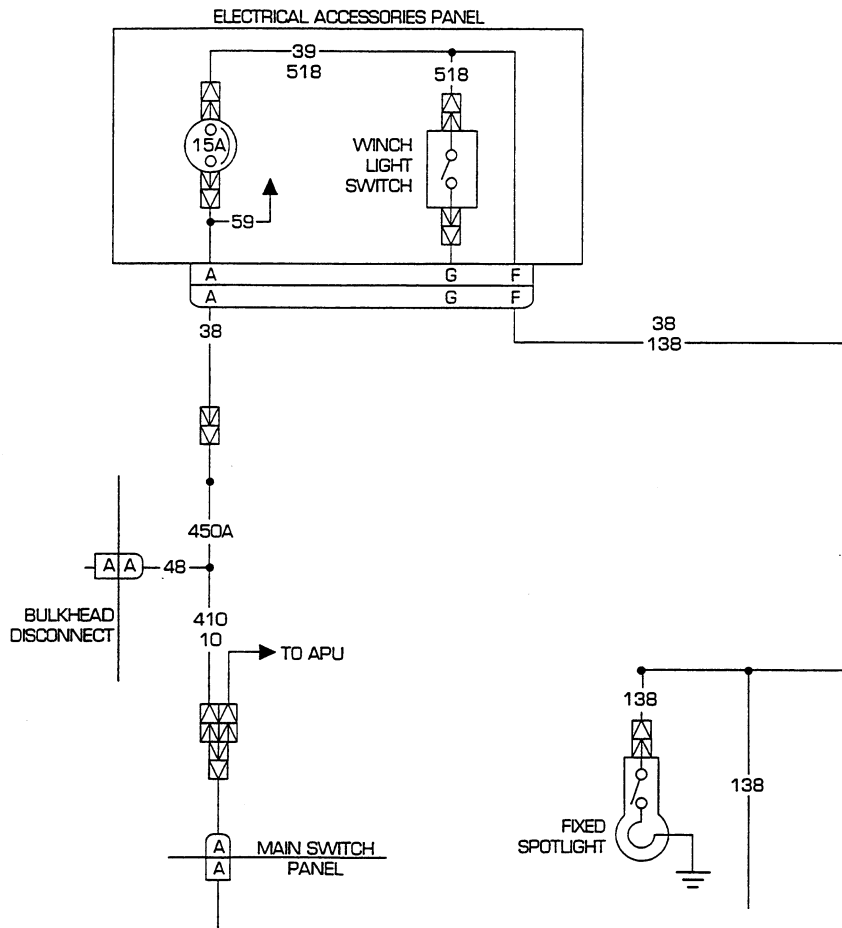
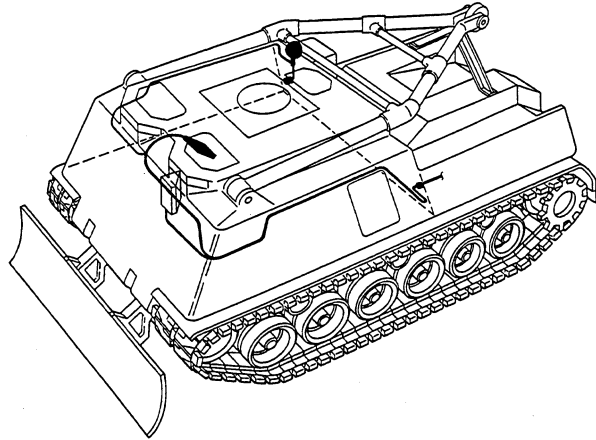

Troubleshooting Procedure

Fixed Spotlight

Symptom

Fixed spotlight malfunctioning.

Malfunction

Fixed spotlight fails to operate. Do steps 1 thru 7.

CORRECTIVE ACTION

WARNING

Remove all jewelry such as rings, dog tags, bracelets, etc. If jewelry contacts a metal surface a direct short may result in instant heating of tools, damage to equipment, and injury or death to personnel.

1. Disconnect wire 138 from fixed spotlight. Place red lead of multimeter on wire 138 and black lead to ground. Turn MASTER switch on and check for voltage. Turn MASTER switch OFF. If voltage is present, replace spotlight (see WP 0181 00). If voltage is not present, go to step 2.

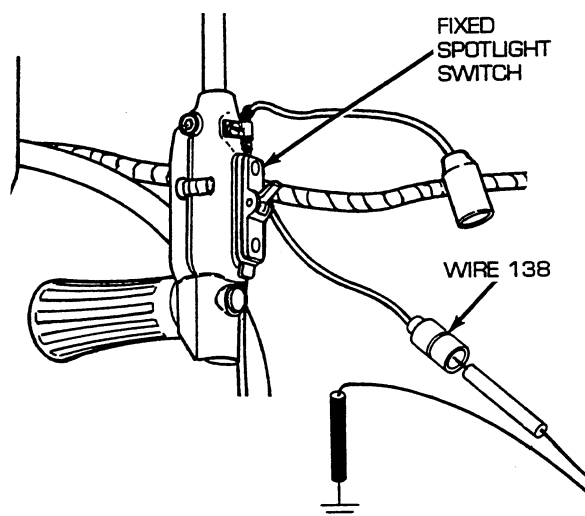

2. Reconnect wire 138 to fixed spotlight. Disconnect electrical accessories panel wiring harness from electrical accessories panel. Place a jumper wire from pin A to socket A of wire 38/59. Place red lead of multimeter on pin F of wire 38 and black lead to ground. Turn MASTER switch on and check for voltage. Turn MASTER switch OFF. If voltage is present, repair/replace wire 38/138 of electrical accessories panel wiring harness (see WP 0196 00). If voltage is not present, go to step 3.

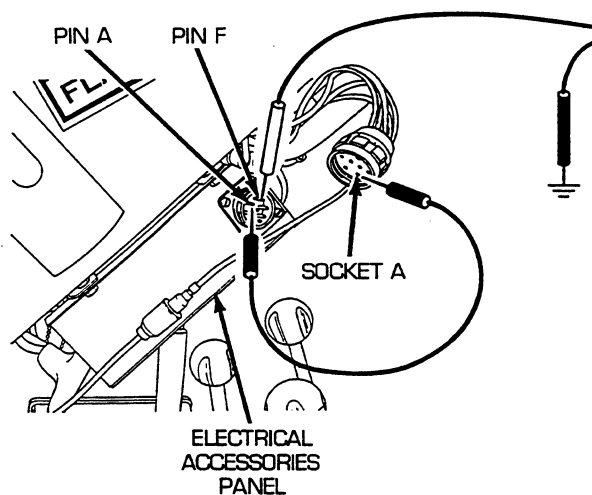

CORRECTIVE ACTION –Continued

- Place red lead of multimeter in socket A of wire 38/59 and black lead to ground. Turn MASTER switch on and check for voltage. Turn MASTER switch OFF. If voltage is present, go to step 4. If voltage is not present, go to step 5.

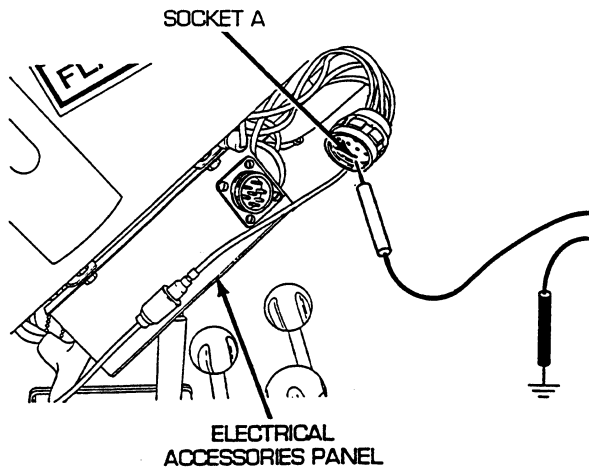

- Remove four screws (1) and four lockwashers (2) and release electrical accessories panel (3). Reconnect electrical accessories panel wiring harness to electrical accessories panel. Disconnect wire 38/518 from winch light switch side of 15 A circuit breaker. Place red lead of multimeter on terminal of 15 A circuit breaker and black lead to ground. Turn MASTER switch on, and check for voltage. Turn MASTER switch OFF. If voltage is present, repair/replace wire 38/518 of bilge pump main power wiring harness from 15 A circuit breaker to electrical accessories panel wiring harness connector (see WP 0233 00). If voltage is not present, go to step 5.

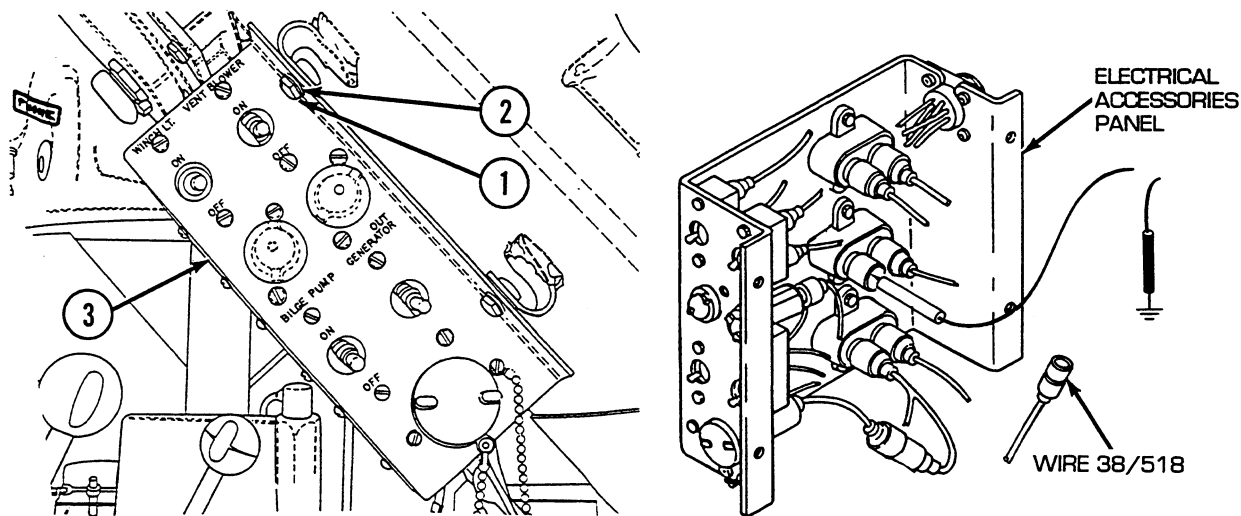

CORRECTIVE ACTION –Continued

5. Reconnect wire 38/518 to winch light switch side of 15 A circuit breaker. Disconnect wire 38/518 from panel connector side of 15 A circuit breaker. Place red lead of multimeter in wire 38/518 and black lead to ground. Turn MASTER switch on, and check for voltage. Turn MASTER switch OFF. If voltage is present, replace 15 A circuit breaker (see WP 0158 00). If voltage is not present, repair/replace wire 38/518 from pin A to 15 A circuit breaker (see WP 0158 00).

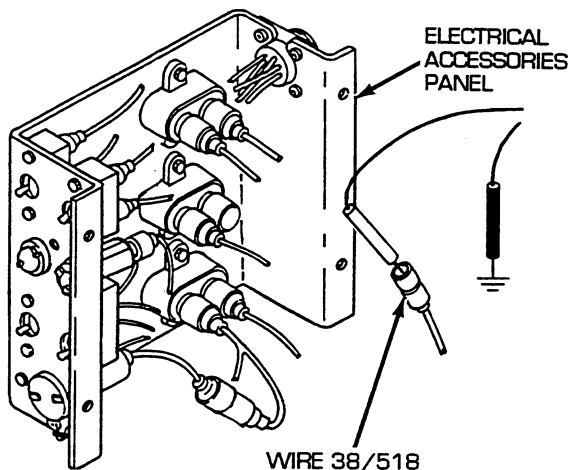

6. Remove three screws (4), three lockwashers (5), ground wire (6), and flat washer (7) and release main switch panel (8) from mounting bracket. Disconnect wire 10-419 from Y-connector of switch panel, radio, and bilge pump to bulkhead wiring harness at main switch panel. Turn MASTER switch on, and check for voltage. If voltage is present, repair wire 419 from Y-connector at main switch panel to APU control box bulkhead wiring harness. If voltage is not present, go to step 7.

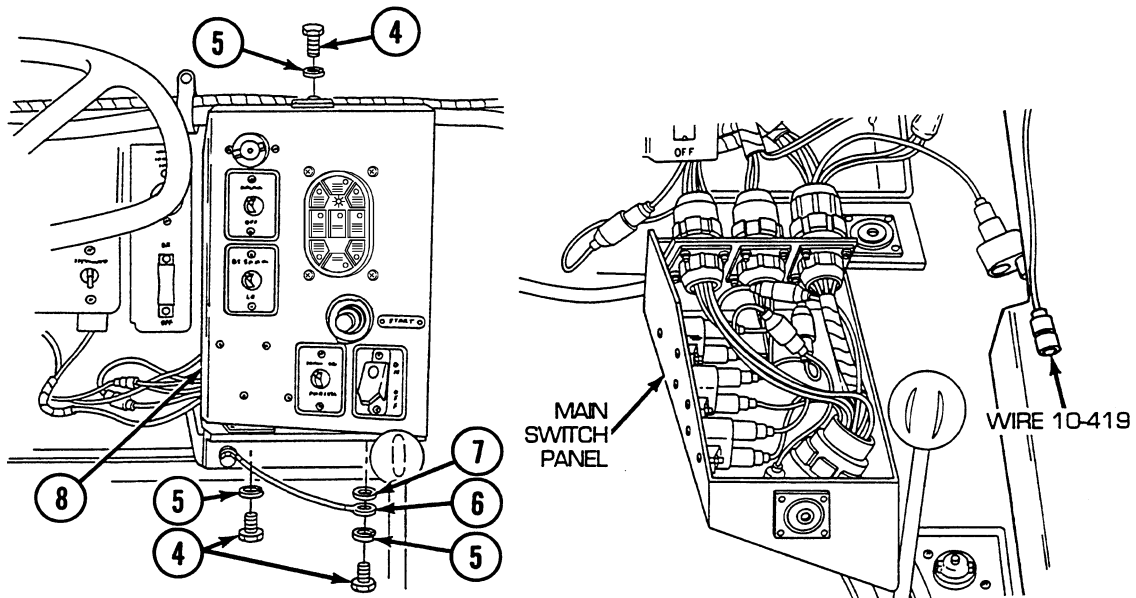

CORRECTIVE ACTION –Continued

7. Reconnect wire 10-419 to Y-connector of switch panel, radio, and bilge pump to bulkhead wiring harness to main switch panel. Install main switch panel (8), flat washer (7), ground wire (6), three lockwashers (5), and three screws (4) to mounting bracket. Open air inlet doors (TM 9-2350-256-10). Disconnect wire 48 pin A from bulkhead to master relay wiring harness. Place red multimeter lead in socket and black lead to ground. Turn MASTER switch on and check for voltage. If voltage is present, repair/replace switch panel, radio, and bilge pump to bulkhead wiring harness (see WP 0202 00). If voltage is not present, troubleshoot master relay circuit (see WP 0042 00).

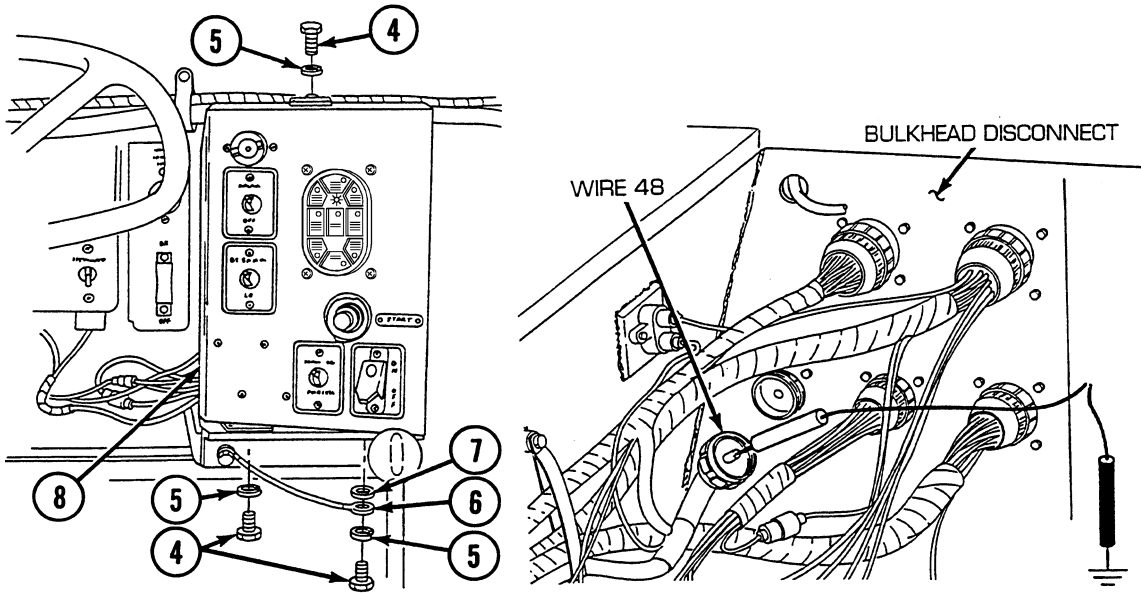

END OF WORK PACKAGE

UNIT MAINTENANCE
RECOVERY VEHICLE, FULL TRACKED: MEDIUM, M88A1
NSN 2350-00-122-6826, EIC AQA
TROUBLELIGHT ASSEMBLY TROUBLESHOOTING PROCEDURE

INITIAL SETUP:**Tools and Special Tools**

Tool kit, general mechanic's (item 59, WP 0490 00)

References

WP 0042 00
WP 0158 00

References (cont.)

WP 0180 00
WP 0196 00
WP 0202 00
WP 0233 00
TM 9-2350-256-10

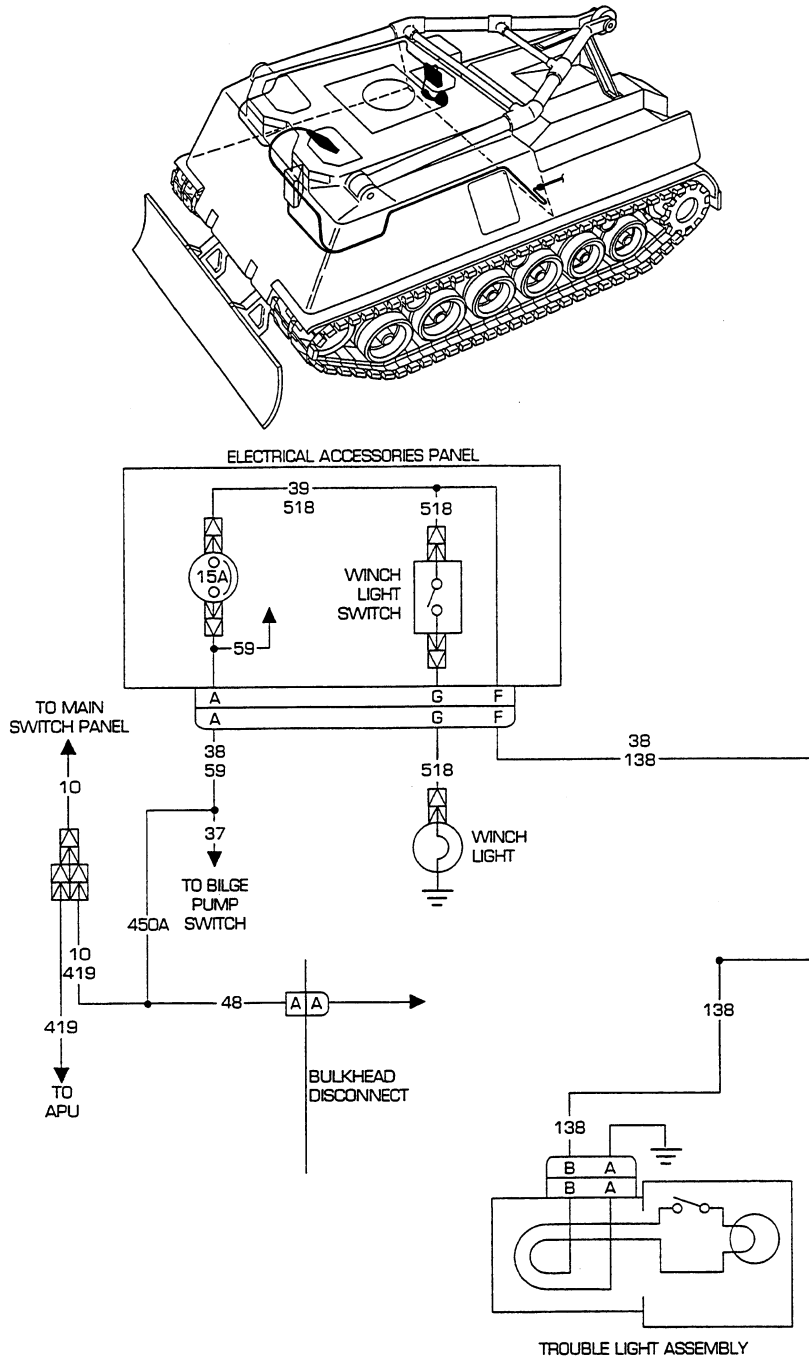

Troubleshooting Procedure

Troublelight Assembly

Symptom

Troublelight assembly malfunctioning.

Malfunction

Troublelight assembly fails to operate. Do steps 1 thru 8.

CORRECTIVE ACTION**WARNING**

Remove all jewelry such as rings, dog tags, bracelets, etc. If jewelry contacts a metal surface a direct short may result in instant heating of tools, damage to equipment, and injury or death to personnel.

1. Disconnect electrical accessories panel wiring harness from troublelight assembly. Place red lead of multimeter in socket B of wire 138 and black lead to ground. Turn MASTER switch on and check for voltage. Turn MASTER switch OFF. If voltage is present, go to step 2. If voltage is not present, go to step 3.

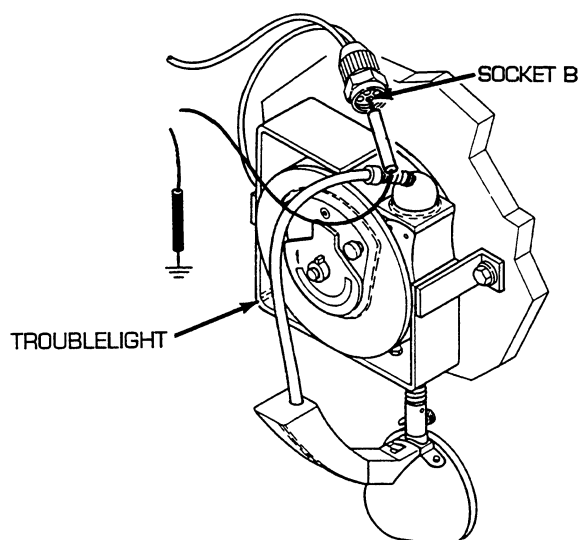

2. Place red lead of multimeter in socket A of GND and black lead to ground. Check for continuity. If continuity is present, replace troublelight (see WP 0180 00). If continuity is not present, repair/replace GND wire of electrical accessories panel wiring harness (see WP 0196 00).

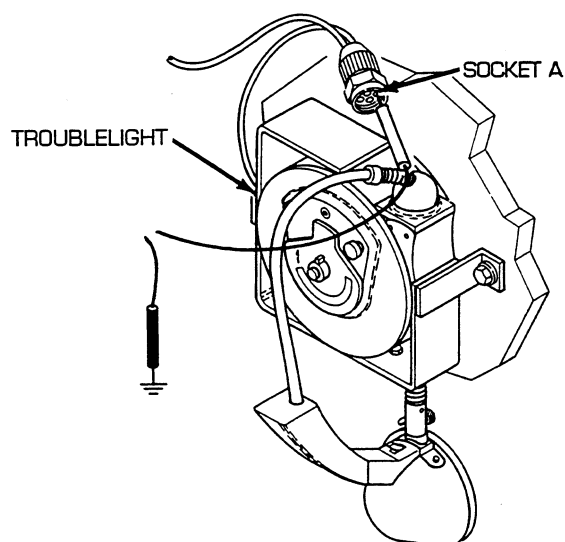

CORRECTIVE ACTION –Continued

3. Disconnect electrical accessories panel wiring harness from electrical accessories panel. Place a jumper wire from pin A to socket A of wire 38/59. Place red lead of multimeter on pin F of wire 38 and black lead to ground. Turn MASTER switch on and check for voltage. Turn MASTER switch OFF. If voltage is present, repair/replace wire 38/138 of electrical accessories panel wiring harness (see WP 0196 00). If voltage is not present, go to step 4.

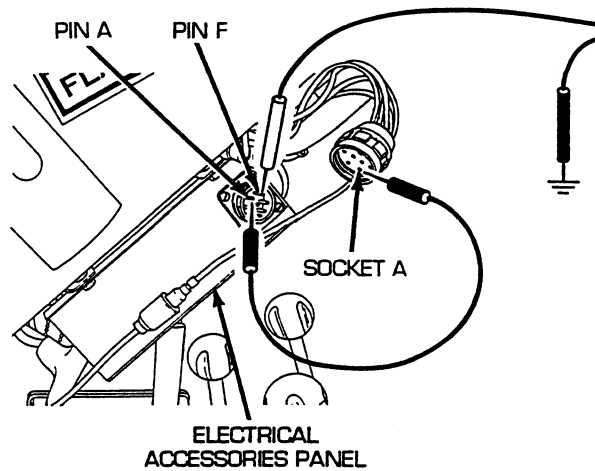

4. Place red lead of multimeter in socket A of wire 38/59 and black lead to ground. Turn MASTER switch on and check for voltage. Turn MASTER switch OFF. If voltage is present, go to step 5. If voltage is not present, go to step 7.

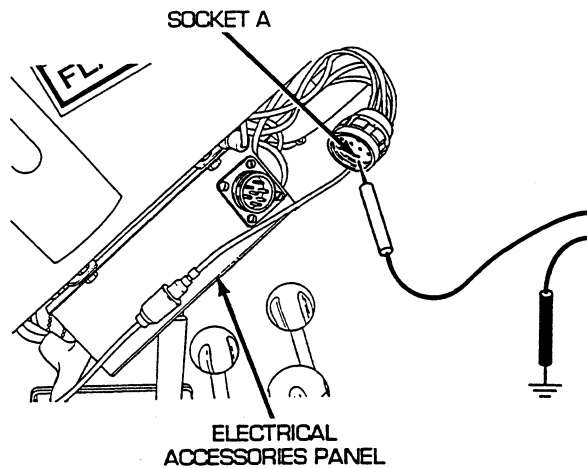

CORRECTIVE ACTION –Continued

5. Reconnect electrical accessories panel wiring harness to electrical accessories panel. Remove four screws (1) and four lockwashers (2) and release electrical accessories panel (3). Disconnect wire 38/518 from winch light switch side of 15 A circuit breaker. Place red lead of multimeter on terminal of 15 A circuit breaker and black lead to ground. Turn MASTER switch on and check for voltage. Turn MASTER switch OFF. If voltage is present, repair/replace wire 38/518 of bilge pump main power wiring harness from 15 A circuit breaker to electrical accessories panel wiring harness (see WP 0233 00). If voltage is not present, go to step 6.

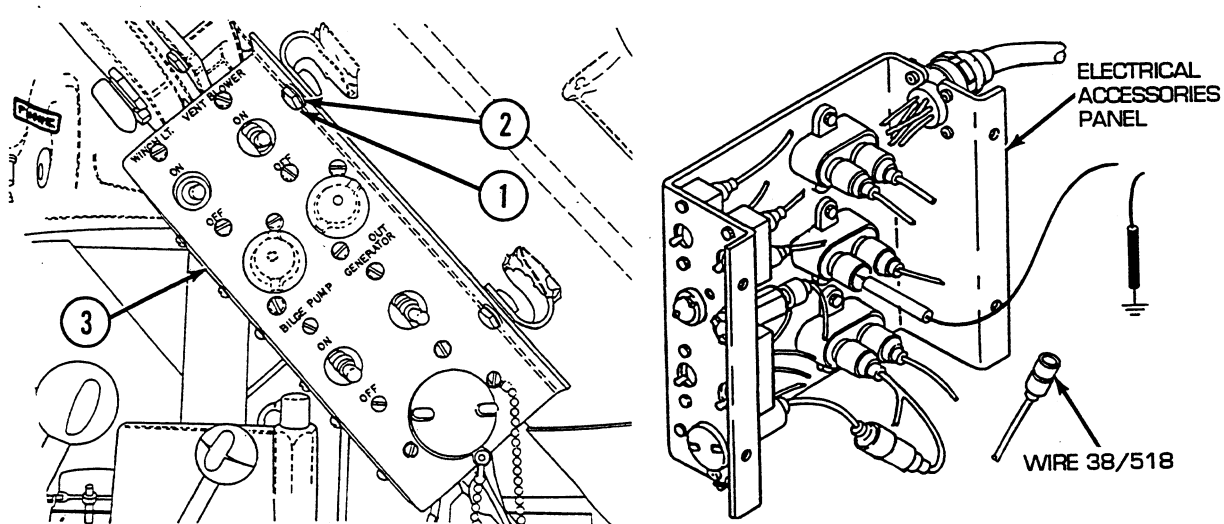

6. Reconnect wire 38/518 to winch light switch side of 15 A circuit breaker. Disconnect wire 38/518 from panel connector side of 15 A circuit breaker. Place red lead of multimeter in wire 38/518 and black lead to ground. Turn MASTER switch on and check for voltage. Turn MASTER switch OFF. If voltage is present, replace 15 A circuit breaker (see WP 0158 00). If voltage is not present, repair/replace wire 38 from pin A to 15 A circuit breaker (see WP 0158 00).

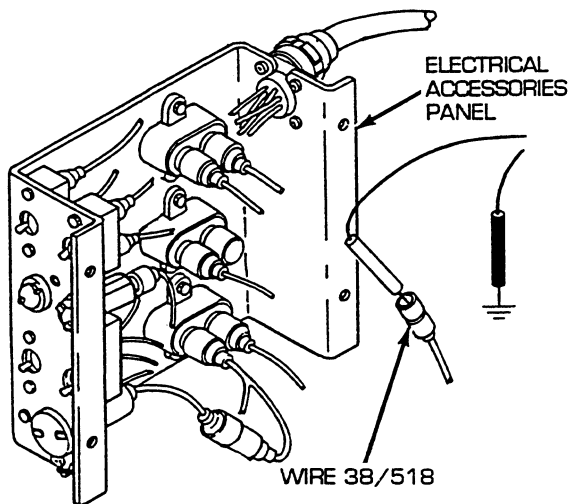

CORRECTIVE ACTION –Continued

- Remove three screws (4), three lockwashers (5), ground wire (6), and flat washer (7) and release main switch panel (8) from mounting bracket. Disconnect wire 10-419 from Y-connector of switch panel, radio, and bilge pump to bulkhead wiring harness at main switch panel. Turn MASTER switch on, and check for voltage. If voltage is present, repair wire 419 from Y-connector at main switch panel to APU control box bulkhead wiring harness. If voltage is not present, go to step 8.

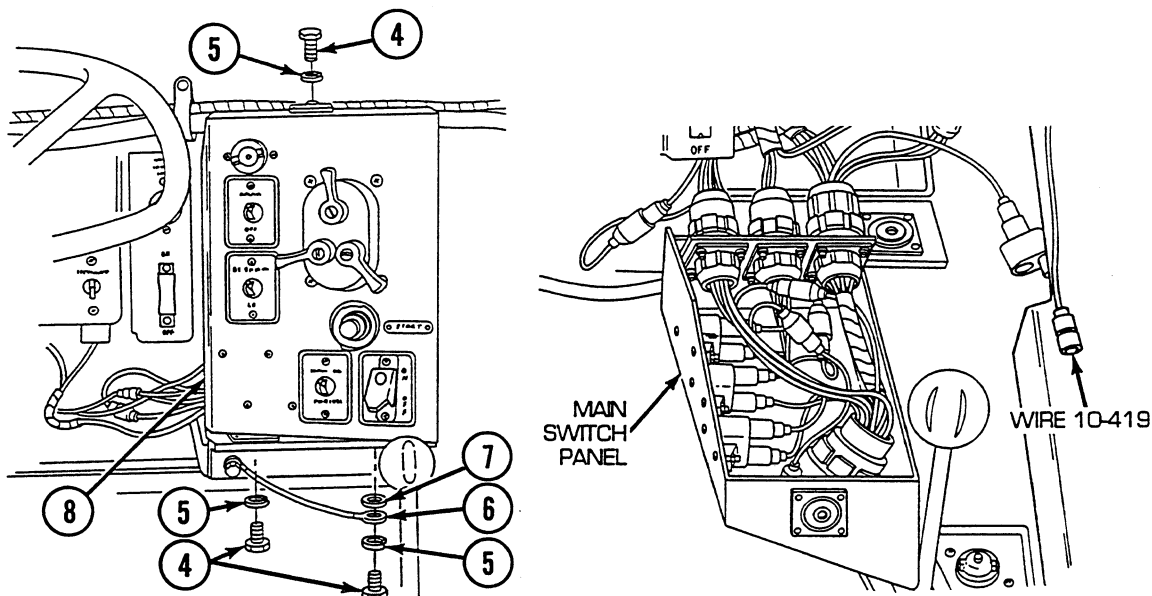

- Reconnect wire 10-419 to Y-connector of switch panel, radio, and bilge pump to bulkhead wiring harness to main switch panel. Install main switch panel (8), flat washer (7), ground wire (6), three lockwashers (5), and three screws (4) to mounting bracket. Open air inlet doors (TM 9-2350-256-10). Disconnect wire 48 pin A from bulkhead to master relay wiring harness. Place red multimeter lead in socket and black lead to ground. Turn MASTER switch on and check for voltage. If voltage is present, repair/replace switch panel, radio, and bilge pump to bulkhead wiring harness (see WP 0202 00). If voltage is not present, troubleshoot master relay circuit (see WP 0042 00).

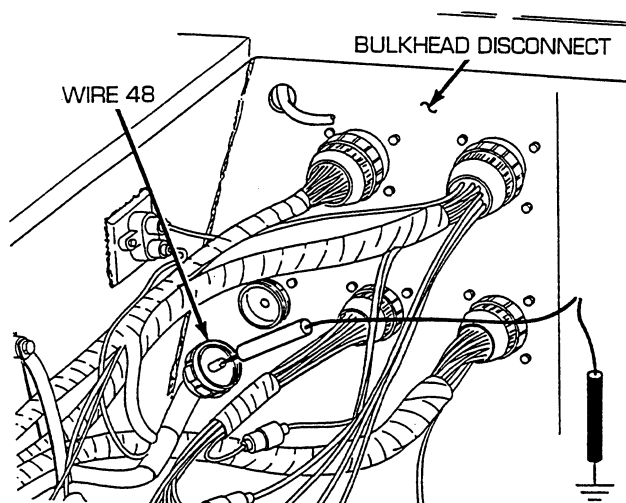

END OF WORK PACKAGE

UNIT MAINTENANCE
RECOVERY VEHICLE, FULL TRACKED: MEDIUM, M88A1
NSN 2350-00-122-6826, EIC AQA
WINCH LIGHT TROUBLESHOOTING PROCEDURE

INITIAL SETUP:**Tools and Special Tools**

Tool kit, general mechanic's (item 59, WP 0490 00)

References

WP 0042 00
WP 0158 00

References (cont.)

WP 0184 00
WP 0196 00
WP 0202 00
WP 0233 00
TM 9-2350-256-10

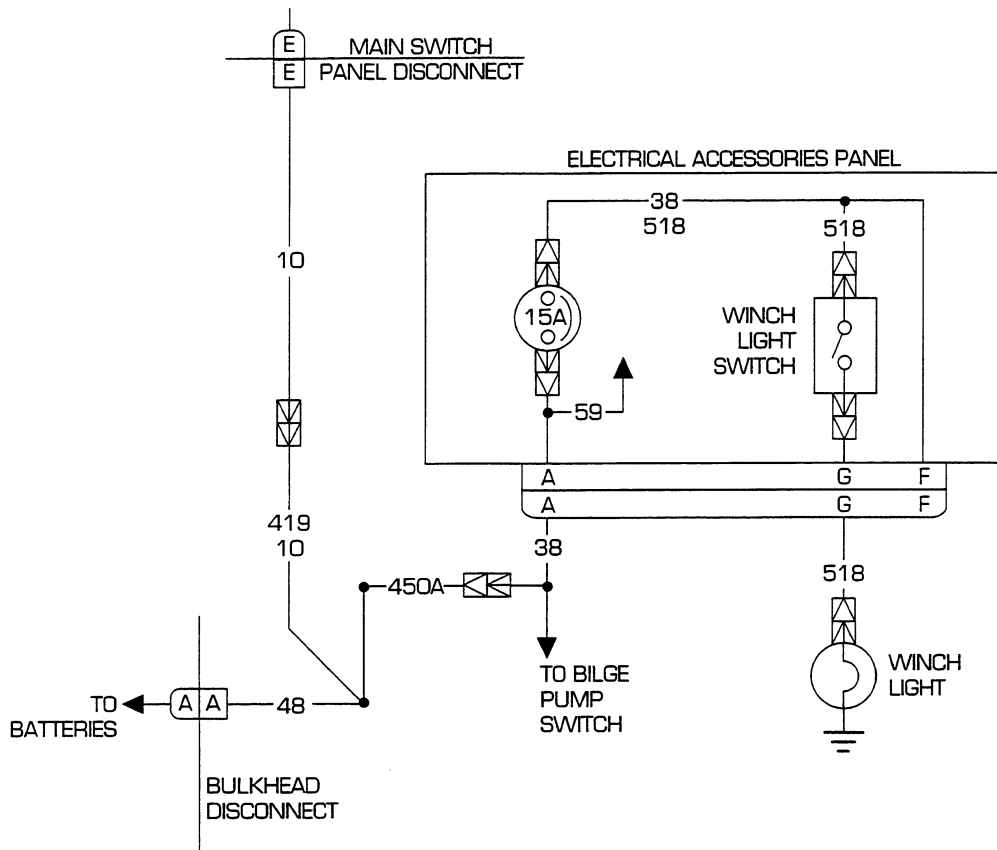
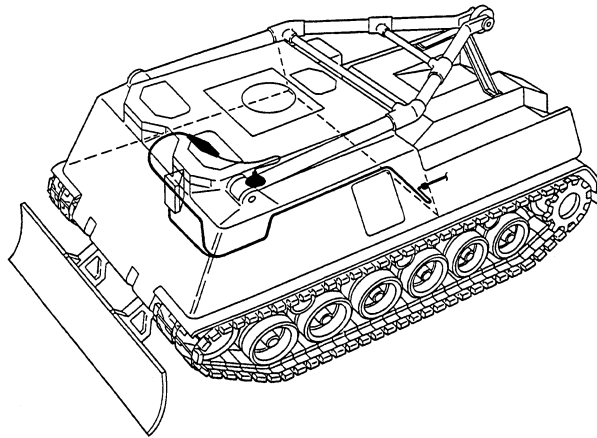

Troubleshooting Procedure

Winch Light

Symptom

Winch light malfunctioning.

Malfunction

Winch light fails to operate. Do steps 1 thru 9.

CORRECTIVE ACTION

WARNING

Remove all jewelry such as rings, dog tags, bracelets, etc. If jewelry contacts a metal surface a direct short may result in instant heating of tools, damage to equipment, and injury or death to personnel.

1. Disconnect wire 518 from winch light. Place red lead of multimeter on wire 518 and black lead to ground. Turn MASTER and WINCH LT switches ON and check for voltage. Turn MASTER and WINCH LT switches OFF. If voltage is present, replace lamp (see WP 0184 00). If voltage is not present, go to step 2.

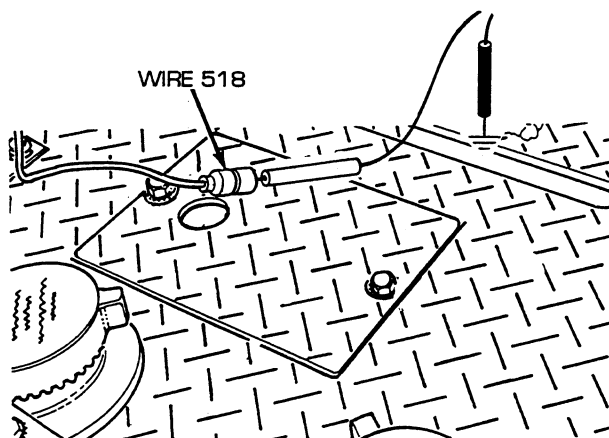

2. Reconnect wire 518 to winch light. Disconnect electrical accessories panel wiring harness from electrical accessories panel. Place a jumper wire from socket A to pin A of wire 38/59. Place red lead of multimeter on pin G of wire 518 and black lead to ground. Turn MASTER and WINCH LT switches ON, and check for voltage. Turn MASTER and WINCH LT switches OFF. If voltage is present, repair/replace wire 518 of electrical accessories panel wiring harness (see WP 0196 00). If voltage is not present, go to step 3.

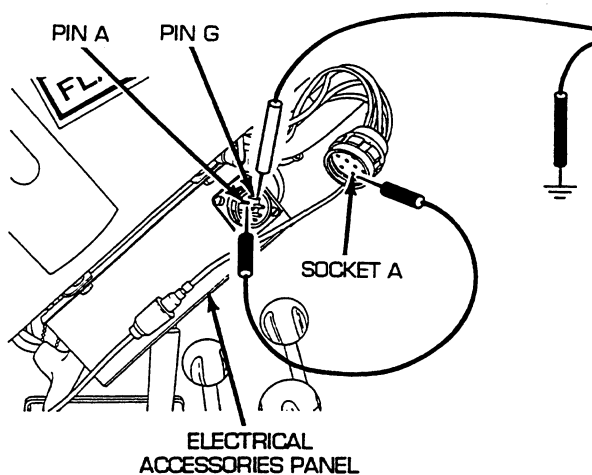

CORRECTIVE ACTION –Continued

3. Place red lead of multimeter in socket A of wire 38/59 and black lead to ground. Turn MASTER switch on and check for voltage. Turn MASTER switch OFF. If voltage is present, go to step 4. If voltage is not present, go to step 8.

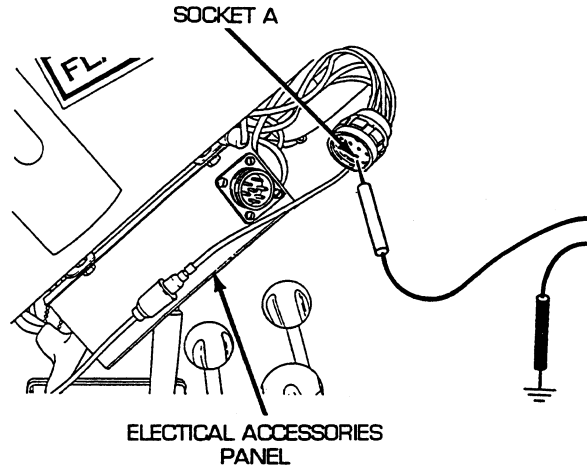

4. Reconnect electrical accessories panel wiring harness to electrical accessories panel. Remove four screws (1) and four lockwashers (2) and release electrical accessories panel (3) from mounting brackets. Disconnect wire 38/518 from panel connector side of 15 A circuit breaker. Place red lead of multimeter in wire 38/518 and black lead to ground. Turn MASTER switch on and check for voltage. Turn MASTER switch OFF. If voltage is present, go to step 5. If voltage is not present, repair/replace wire 38/518 of bilge pump main power wiring harness from panel connector to circuit breaker (see WP 0233 00).

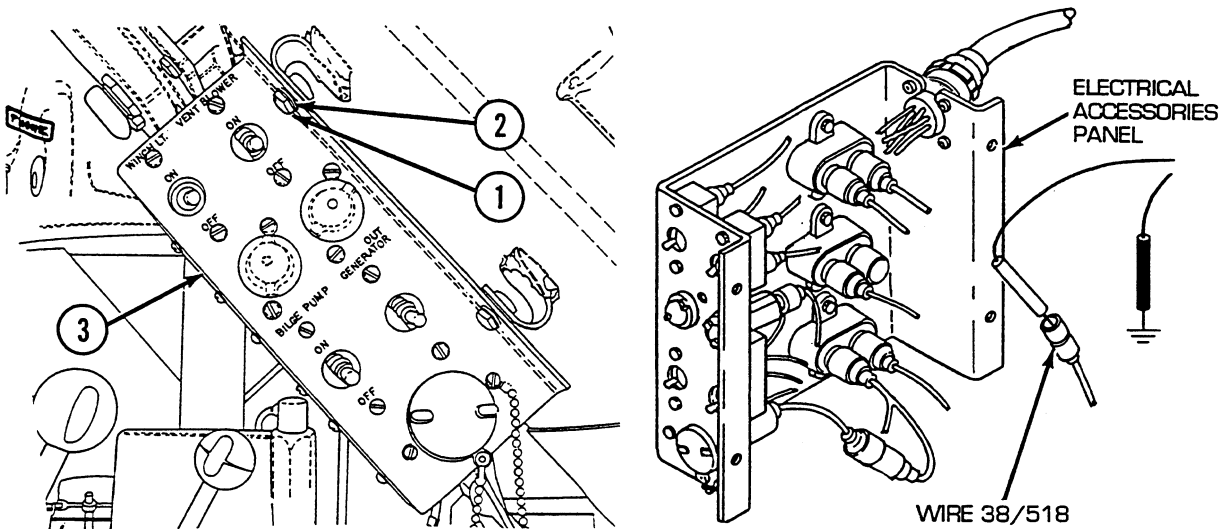

CORRECTIVE ACTION –Continued

5. Reconnect wire 38/518 to panel connector side of 15 A circuit breaker. Disconnect wire 38/518 from winch light switch side of 15 A circuit breaker. Place red lead of multimeter on terminal of 15 A circuit breaker and black lead to ground. Turn MASTER switch on and check for voltage. Turn MASTER switch OFF. If voltage is present, go to step 6. If voltage is not present, replace 15 A circuit breaker (see WP 0158 00).

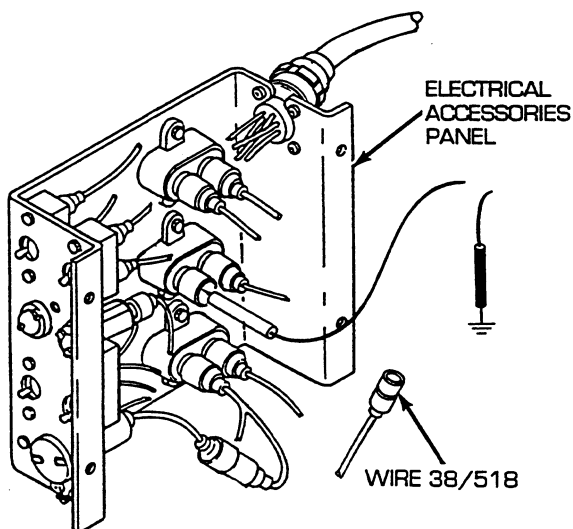

6. Reconnect wire 38/518 to 15 A circuit breaker. Disconnect wire 518 from circuit breaker side of winch light switch. Place red lead of multimeter in wire 518 and black lead to ground. Turn MASTER switch on and check for voltage. Turn MASTER switch OFF. If voltage is present, go to step 6. If voltage is not present, repair/replace wire 38/518 of bilge pump main power wiring harness from 15 A circuit breaker to winch light switch (see WP 0233 00).

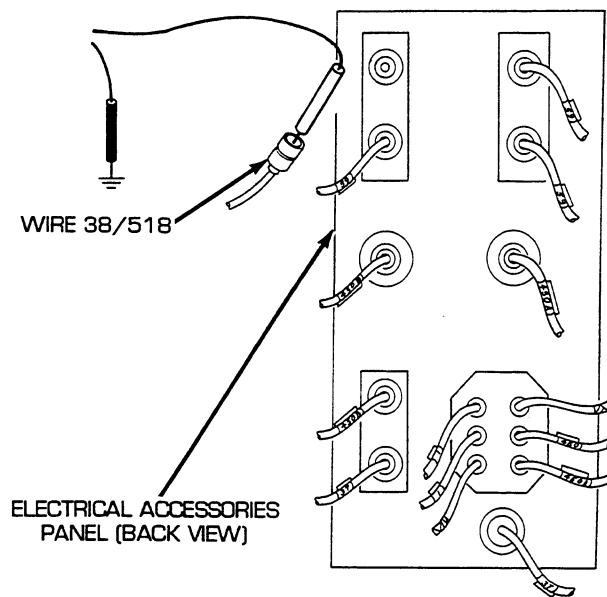

CORRECTIVE ACTION –Continued

7. Reconnect wire 518 to circuit breaker side of winch light switch. Disconnect wire 518 from panel connector side of winch light switch. Place red lead of multimeter on terminal of winch light switch and black lead to ground. Turn MASTER and WINCH LT switches ON and check for voltage. Turn MASTER and WINCH LT switches OFF. If voltage is present, repair/replace wire 518 of bilge pump main power wiring harness from winch light switch to panel connector (see WP 0233 00). If voltage is not present, replace winch light switch (see WP 0158 00).

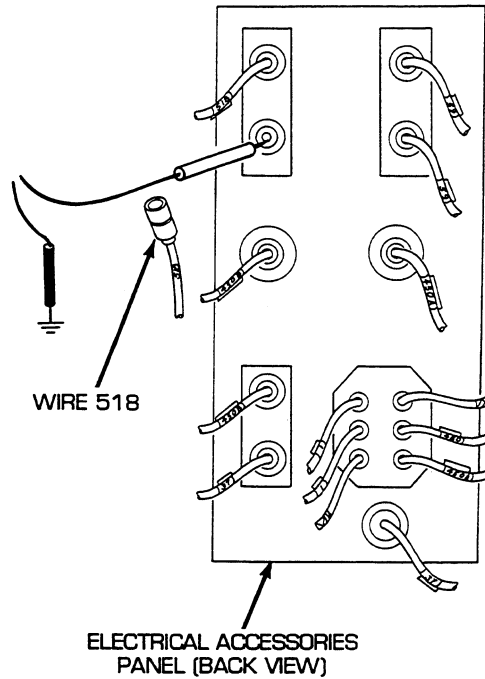

CORRECTIVE ACTION –Continued

8. Reconnect electrical accessories panel wiring harness to electrical accessories panel. Remove three screws (4), three lockwashers (5), ground wire (6), and flat washer (7) and release main switch panel (8) from mounting bracket. Disconnect wire 10-419 from Y-connector of switch panel, radio, and bilge pump to bulkhead wiring harness at main switch panel. Turn MASTER switch on and check for voltage. If voltage is present, repair wire 419 from Y-connector at main switch panel to APU control box bulkhead wiring harness. If voltage is not present, go to step 9.

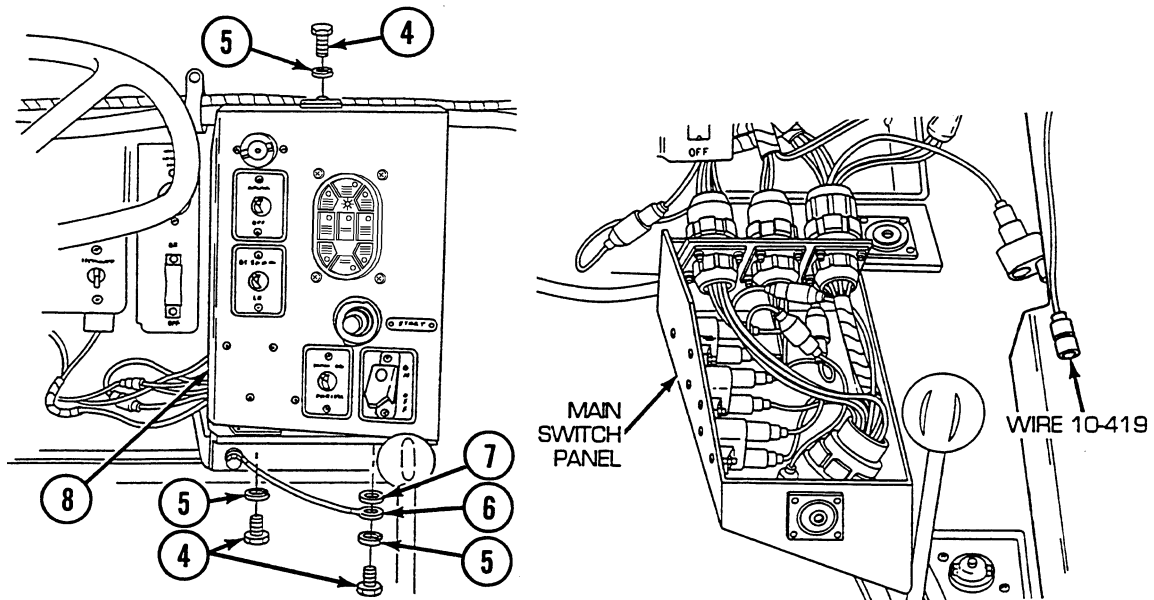

9. Reconnect wire 10-419 to Y-connector of switch panel, radio, and bilge pump to bulkhead wiring harness to main switch panel. Install main switch panel (8), flat washer (7), ground wire (6), three lockwashers (5), and three screws (4) to mounting bracket. Open air inlet doors (TM 9-2350-256-10). Disconnect wire 48 pin A from bulkhead to master relay wiring harness. Place red multimeter lead in socket and black lead to ground. Turn MASTER switch on and check for voltage. If voltage is present, repair/replace switch panel, radio, and bilge pump to bulkhead wiring harness (see WP 0202 00). If voltage is not present, troubleshoot master relay circuit (see WP 0042 00).

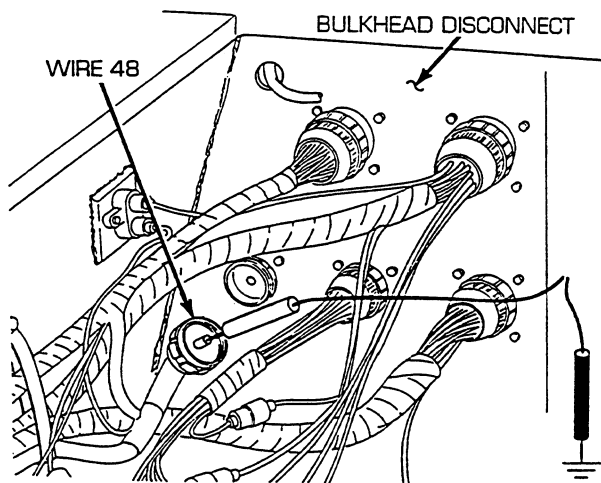

END OF WORK PACKAGE

UNIT MAINTENANCE
RECOVERY VEHICLE, FULL TRACKED: MEDIUM, M88A1
NSN 2350-00-122-6826, EIC AQA
GAGE PANEL LIGHTS TROUBLESHOOTING PROCEDURE

INITIAL SETUP:**Tools and Special Tools**

Tool kit, general mechanic's (item 59, WP 0490 00)

References

WP 0042 00

WP 0157 00

WP 0159 00

WP 0193 00

WP 0194 00

References (cont.)

WP 0195 00

WP 0202 00

WP 0204 00

WP 0205 00

WP 0218 00

WP 0219 00

TM 9-2350-256-10

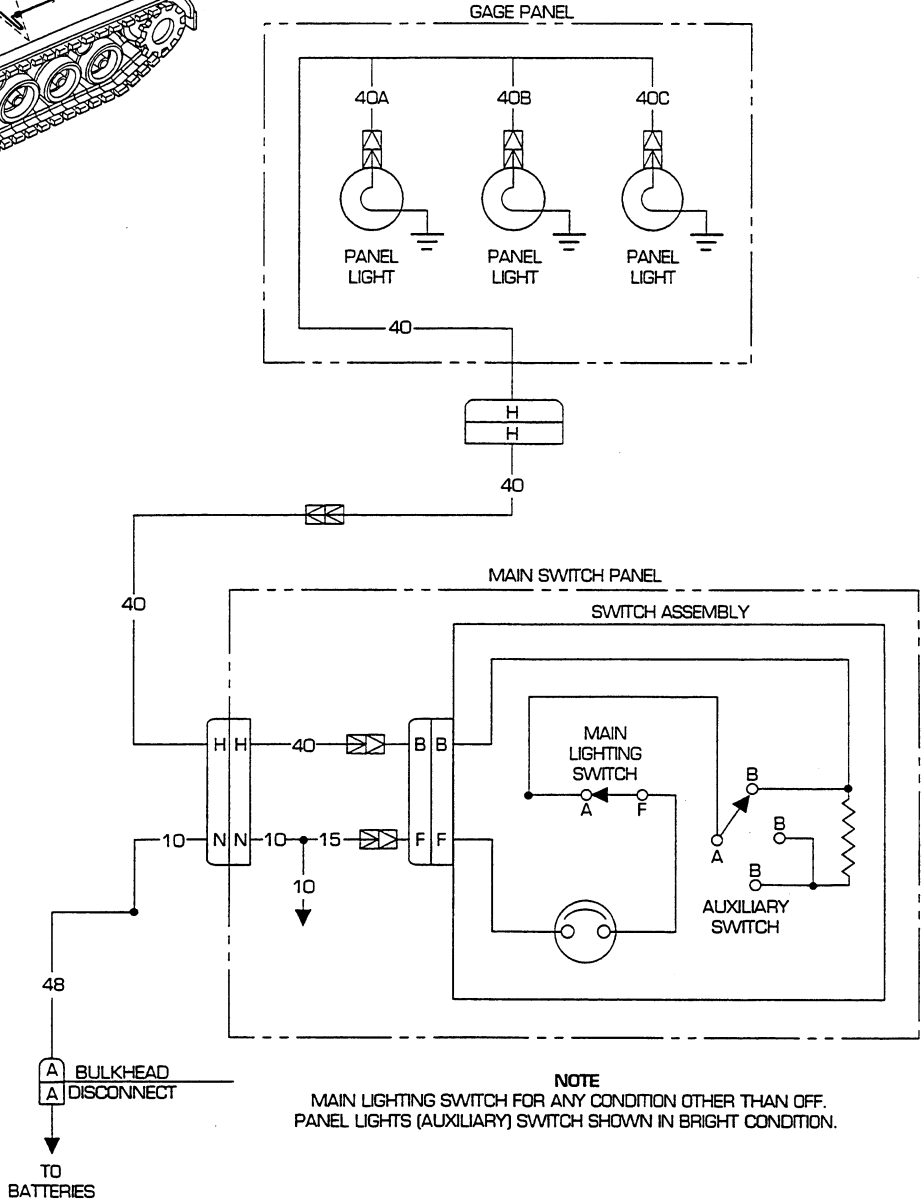
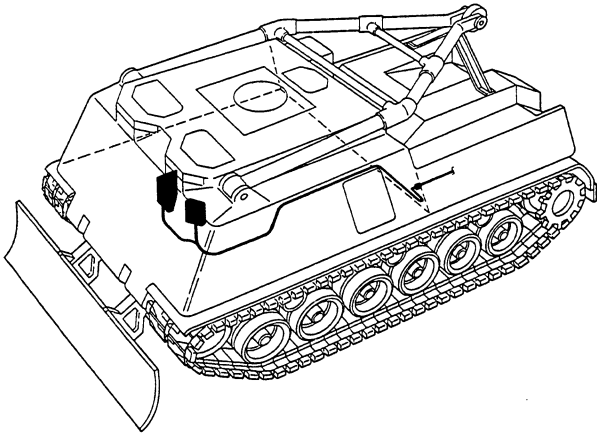

Troubleshooting Procedure

Gage Panel Lights

Symptom

Gage panel lights malfunctioning.

Malfunction

One or more gage panel lights fail to light. Do steps 1 thru 11.

CORRECTIVE ACTION

WARNING

Remove all jewelry such as rings, dog tags, bracelets, etc. If jewelry contacts a metal surface a direct short may result in instant heating of tools, damage to equipment, and injury or death to personnel.

1. Remove lamp from socket. Place red lead of multimeter in socket and black lead to ground. Turn MASTER switch on and check for voltage. Turn MASTER switch OFF. If voltage is present, replace lamp (see WP 0157 00). If voltage is not present, go to step 2.

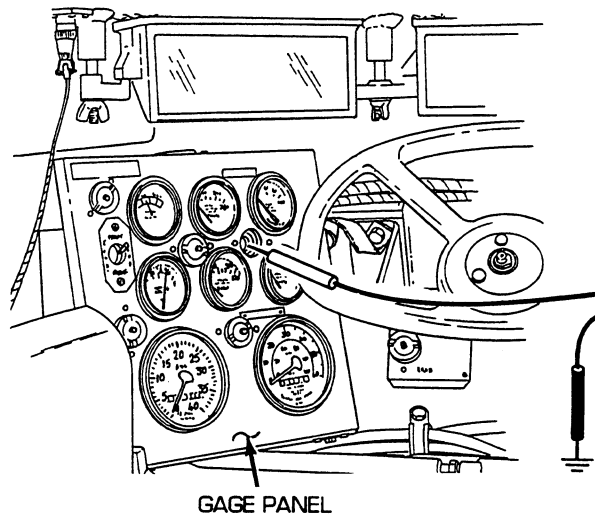

CORRECTIVE ACTION –Continued

- Remove three screws (1), three lockwashers (2), two screws (3), two lockwashers (4), and ground strap (5) and release gage panel (6) from mounting brackets. Disconnect wire 40A, 40B, and/or 40C of gage panel wiring harness from gage panel light(s). Place red lead of multimeter in wire 40A, 40B, and/or 40C and black lead to ground. Turn MASTER switch on and check for voltage in each wire. Turn MASTER switch OFF. If voltage is present, replace socket (see WP 0157 00). If voltage is not present, go to step 3.

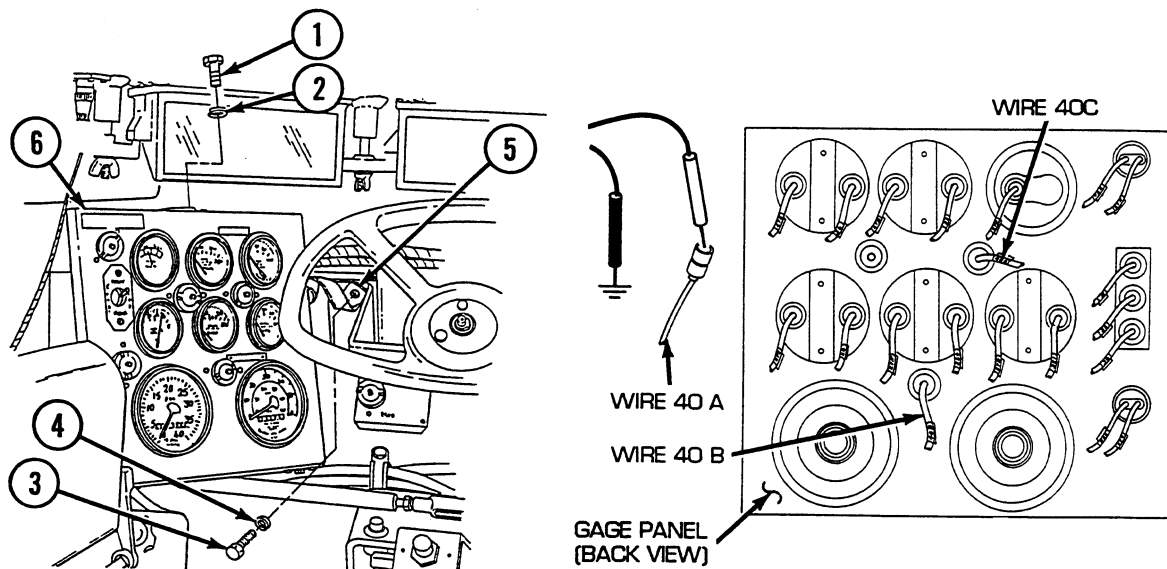

- Disconnect gage panel to bulkhead wiring harness from gage panel. Place red lead of multimeter in socket H of wire 40 and black lead to ground. Turn MASTER switch on and check for voltage. Turn MASTER switch OFF. If voltage is present, repair/replace wire 40A, 40B, and/or 40C of gage panel wiring harness (see WP 0193 00). If voltage is not present, go to step 4.

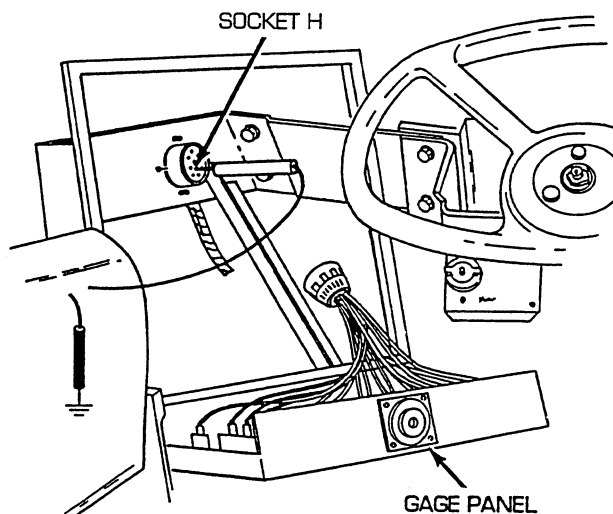

- Reconnect gage panel to bulkhead wiring harness to gage panel. Install ground strap (5), two lockwashers (4), two screws (3), gage panel (6), three lockwashers (2), and three screws (1) to mounting brackets. Remove three screws (7), three lockwashers (8), ground lead (9), and flat washer (10) and release main switch panel (11) from mounting brackets. Disconnect switch panel to gage panel and miscellaneous switches wiring harness from main switch panel. Place jumper wire from socket N to pin N. Place red lead of multimeter in socket H of wire 40 and black lead to ground. Turn MASTER

CORRECTIVE ACTION –Continued

switch on and check for voltage. Turn MASTER switch OFF. If voltage is present, go to step 6. If voltage is not present, go to step 7.

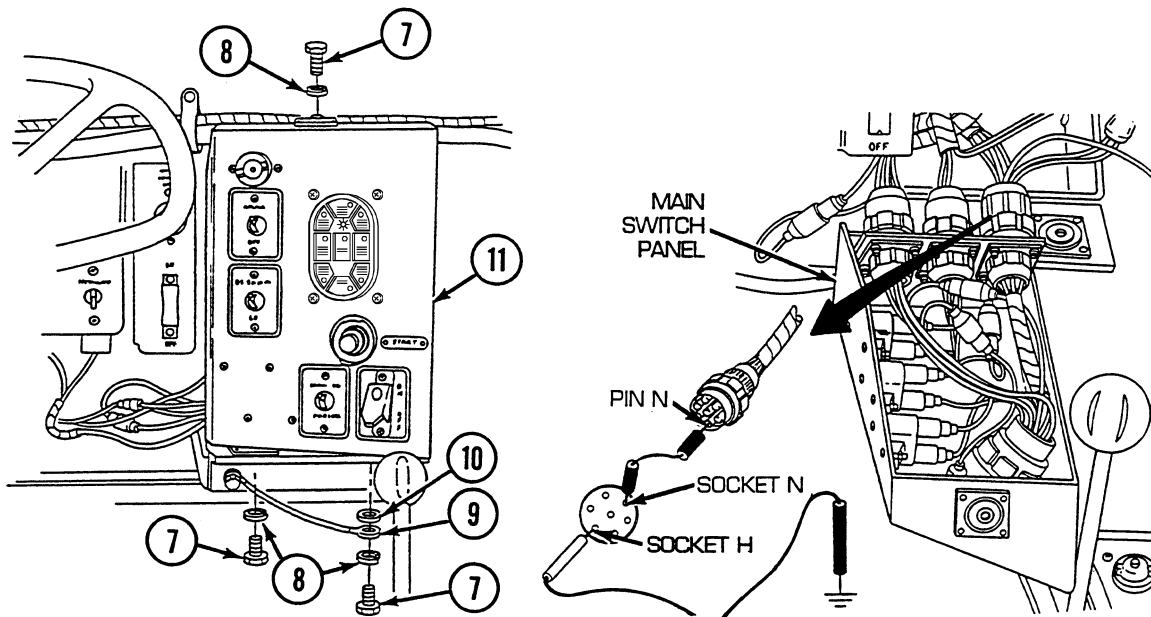

5. Reconnect switch panel to gage panel and miscellaneous switches wiring harness to main switch panel. Install main switch panel (11), flat washer (10), ground lead (9), three lockwashers (8), and three screws (7). Disconnect wire 40 of gage panel to bulkhead wiring harness from switch panel to gage panel and miscellaneous switches wiring harness. Place red lead of multimeter on male connector of wire 40 and black lead to ground. Turn MASTER switch on and check for voltage. Turn MASTER switch OFF. If voltage is present, repair/replace wire 40 of gage panel to bulkhead wiring harness (see WP 0194 00 for dual voltage; 0195 00 for single voltage). If voltage is not present, repair/replace wire 40 of switch panel to gage panel and miscellaneous switches wiring harness (see WP 0204 00 for dual voltage; 0205 00 for single voltage).

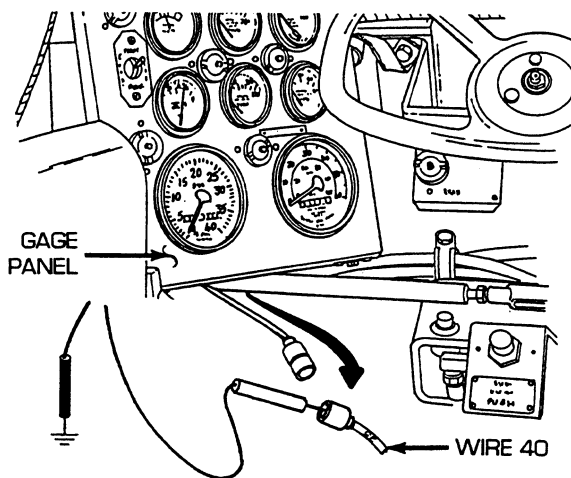

CORRECTIVE ACTION –Continued

6. Place red lead of multimeter on pin N of wire 10/15 and black lead to ground. Turn MASTER switch on and check for voltage. Turn MASTER switch OFF. If voltage is present, go to step 7. If voltage is not present, go to step 11.

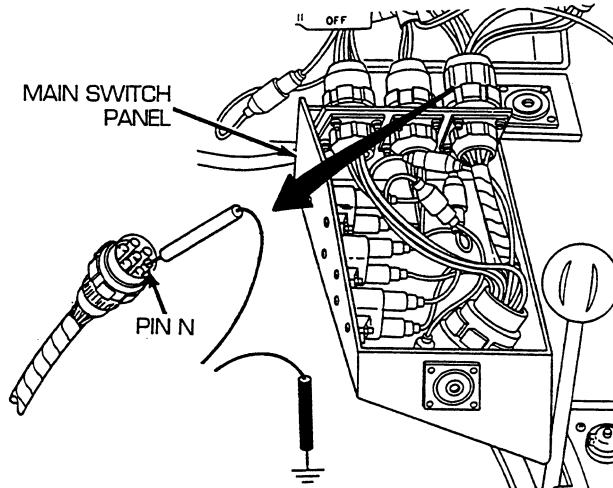

7. Reconnect switch panel to gage panel and miscellaneous switches wiring harness to main switch panel. Disconnect main lighting and master relay wiring harness from main lighting switch. Place a jumper wire from pin F to socket F. Place red multimeter lead on pin B of wire 40 and black lead to ground. Turn MASTER switch on and check for voltage. Turn MASTER switch OFF. If voltage is present, go to step 8. If voltage is not present, go to step 9.

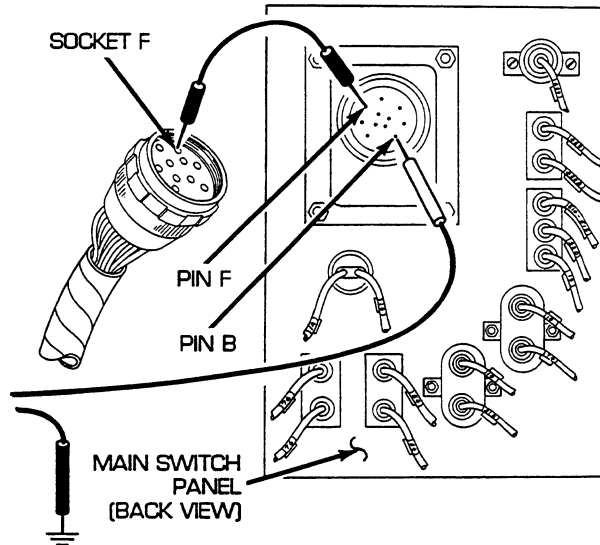

CORRECTIVE ACTION –Continued

8. Reconnect main lighting and master relay wiring harness to main lighting switch. Disconnect wire 40 from main lighting and master relay wiring harness connector in switch panel. Place red lead of multimeter on male connector of wire 40 and black lead to ground. Turn MASTER switch on and check for voltage. Turn MASTER switch OFF. If voltage is present, repair/replace wire 40 of main lighting and B.O. selector switch wiring harness (see WP 0218 00). If no voltage is present, repair/replace wire 40 of main lighting and master relay wiring harness (see WP 0219 00).

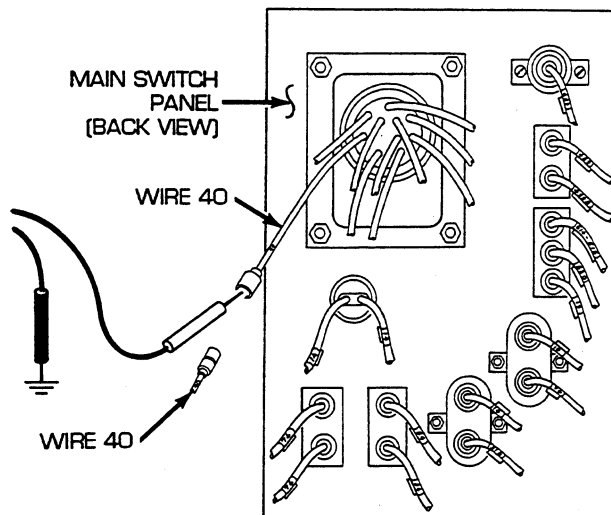

9. Place red lead of multimeter in socket F of wire 10/15 and black lead to ground. Turn MASTER switch on and check for voltage. Turn MASTER switch OFF. If voltage is present repair main lighting switch (see WP 0159 00). If no voltage is present, go to step 10.

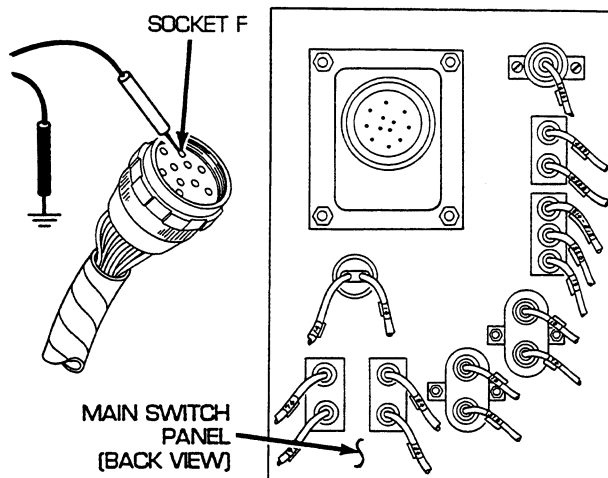

CORRECTIVE ACTION –Continued

10. Reconnect main lighting and master relay wiring harness to main lighting switch. Disconnect wire 10 of main lighting and B.O. selector switch wiring harness from wire 15 of main lighting and master relay wiring harness. Place red lead of multimeter in wire 10 and black to ground. Turn MASTER switch on and check for voltage. Turn MASTER switch OFF. If voltage is present, repair/replace wire 15 of main lighting and master relay wiring harness (see WP 0219 00). If voltage is not present, repair/replace wire 10 of main lighting and B.O. selector switch wiring harness (see WP 0218 00).

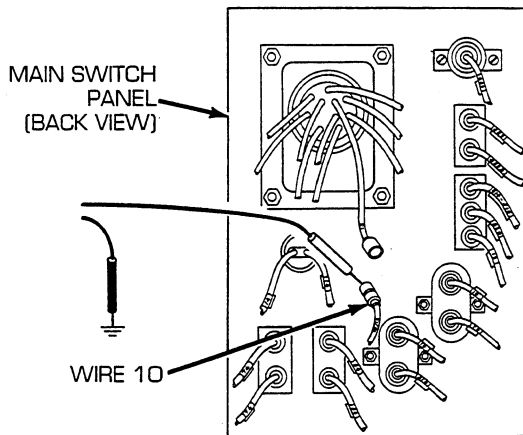

11. Reconnect switch panel to gage panel and miscellaneous switches wiring harness to main switch panel. Install main switch panel (11), flat washer (10), ground lead (9), three lockwashers (8), and three screws (7) to mounting brackets. Open air inlet doors (TM 9-2350-256-10). Disconnect wire 48 pin A from bulkhead to master relay wiring harness. Place red multimeter lead in socket and black lead to ground. Turn MASTER switch on and check for voltage. If voltage is present, repair/replace switch panel, radio, and bilge pump to bulkhead wiring harness (see WP 0202 00). If voltage is not present, troubleshoot master relay circuit (see WP 0042 00).

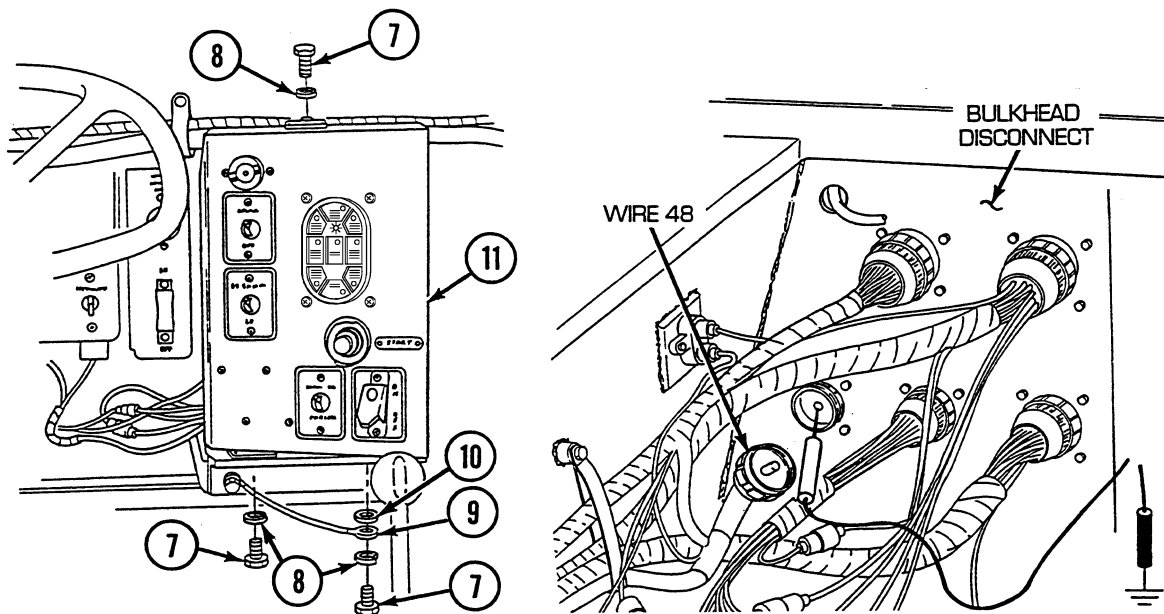

END OF WORK PACKAGE

UNIT MAINTENANCE
RECOVERY VEHICLE, FULL TRACKED: MEDIUM, M88A1
NSN 2350-00-122-6826, EIC AQA
SERVICE HEADLIGHTS TROUBLESHOOTING PROCEDURE

INITIAL SETUP:**Tools and Special Tools**

Tool kit, general mechanic's (item 59, WP 0490 00)

References

WP 0042 00
WP 0174 00
WP 0175 00
WP 0202 00

References (cont.)

WP 0204 00
WP 0205 00
WP 0214 00
WP 0218 00
WP 0219 00
TM 9-2350-256-10

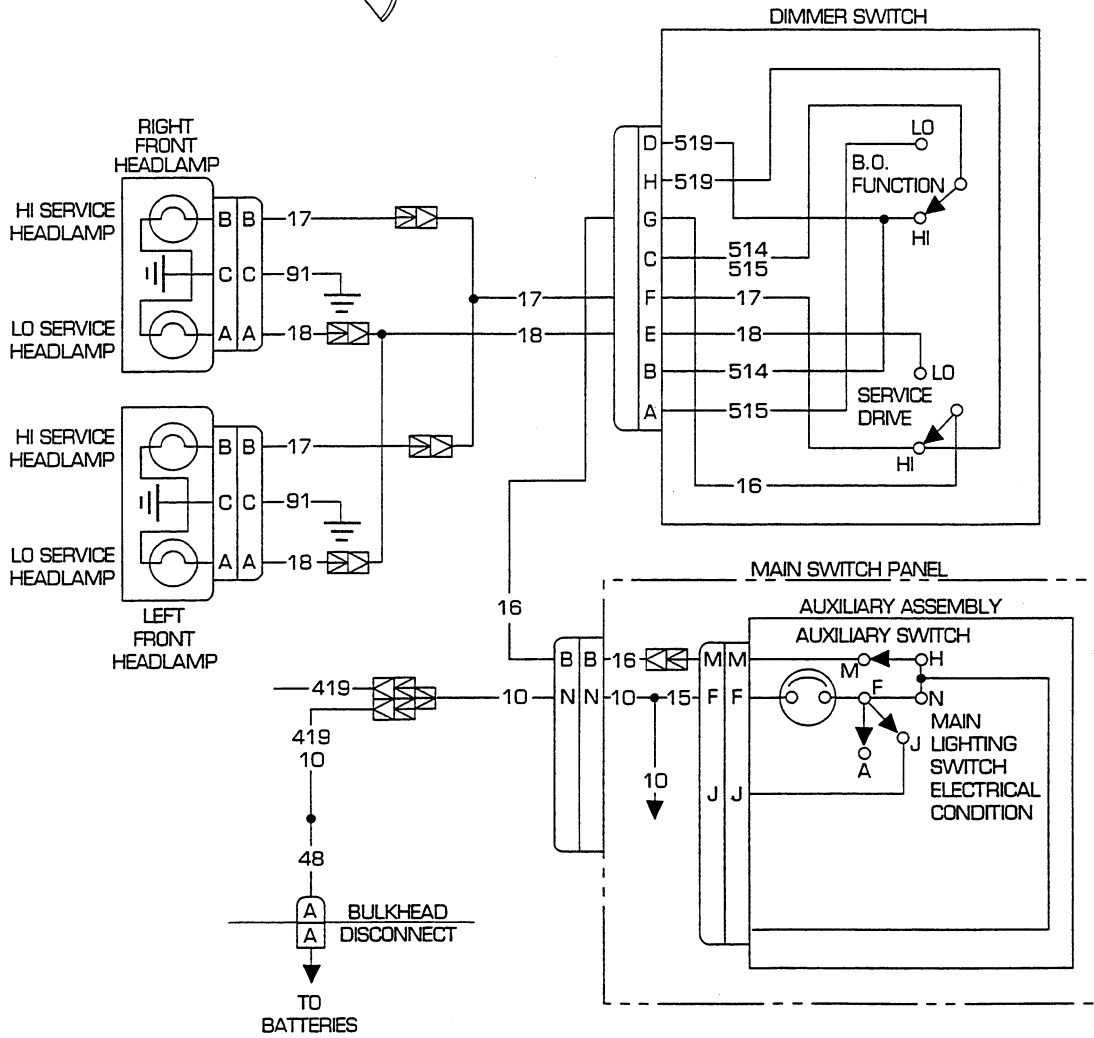
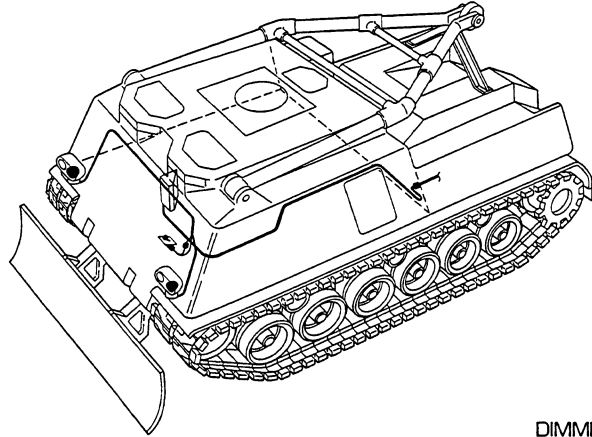

Troubleshooting Procedure

Service Headlights

Symptom

Service headlights malfunctioning.

Malfunction

Service headlights fail to operate. Do steps 1 thru 13.

CORRECTIVE ACTION

WARNING

Remove all jewelry such as rings, dog tags, bracelets, etc. If jewelry contacts a metal surface a direct short may result in instant heating of tools, damage to equipment, and injury or death to personnel.

1. Loosen four screws (1) and remove headlight cover (2). Remove lamp (3) and disconnect connector. Place red lead of multimeter in socket A of wire 18. Turn MASTER switch on, and press SER DRIVE key and ENTER key of main lighting switch, and check for voltage. Press ALL OFF key and ENTER key of main lighting switch and turn MASTER switch off. If voltage is present, replace lamp. If voltage is not present, go to step 2.

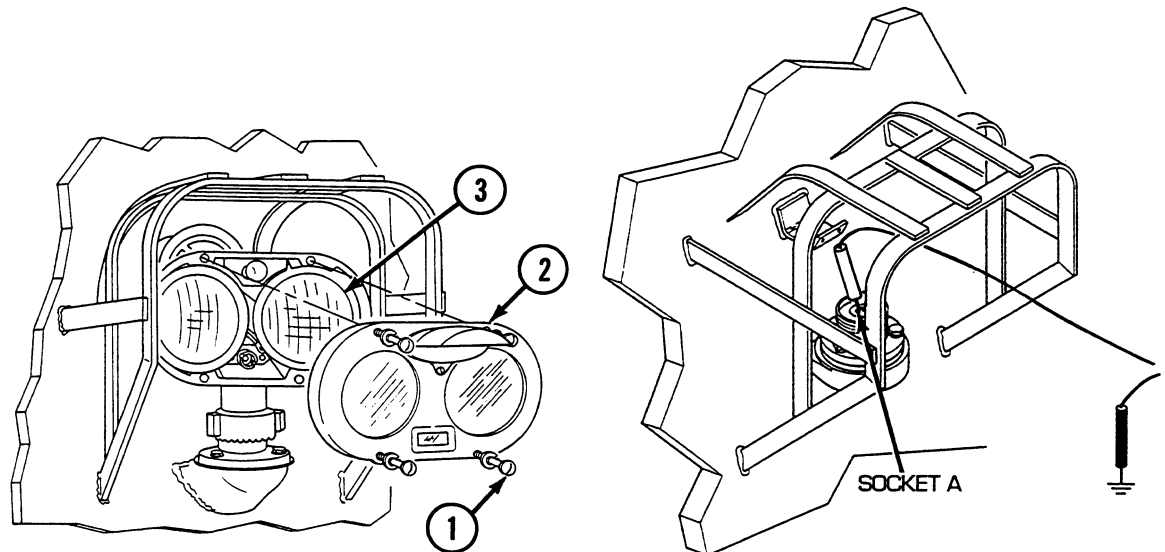

CORRECTIVE ACTION –Continued

2. Install lamp (3), headlight cover (2), and tighten four screws (1). Loosen adjustment nut (4) and remove headlight assembly (5). Place red lead of multimeter in socket A of wire 18 and black lead to ground. Turn MASTER switch on, and press SER DRIVE key and ENTER key of main lighting switch, and check for voltage. Press ALL OFF key and ENTER key of main lighting switch and turn MASTER switch off. If voltage is present, replace headlight assembly (see WP 0175 00). If voltage is not present, go to step 3.

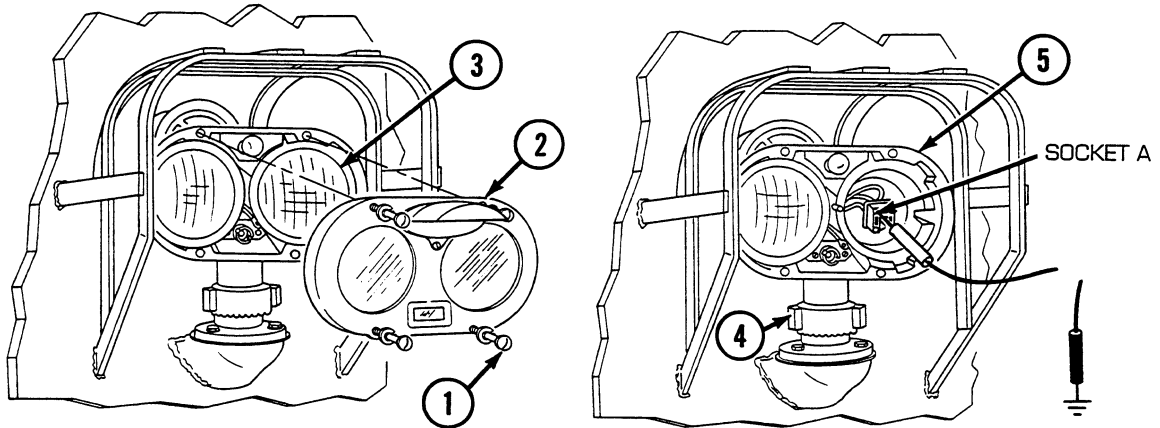

3. Place red lead of multimeter in socket C of wire 91 (ground) and black lead to ground. Check for continuity. If continuity is present, go to step 4. If continuity is not present, repair/replace wire 91 (ground) of headlight and dimmer switch wiring harness (see WP 0214 00).

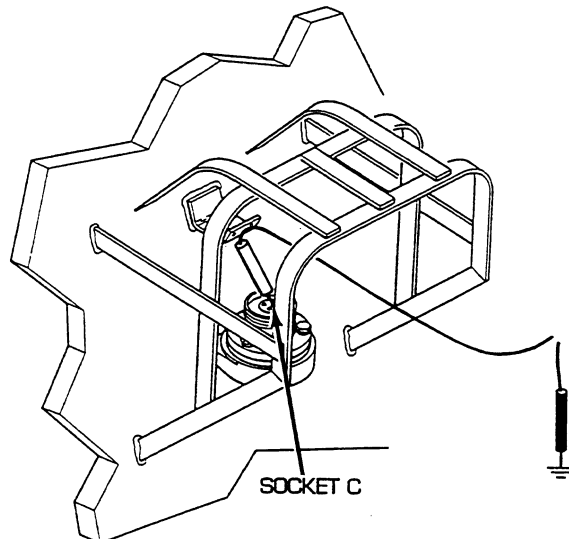

CORRECTIVE ACTION –Continued

4. Place red lead of multimeter in socket G of wire 16 and black lead to ground. Turn MASTER switch on, and press SER DRIVE key and ENTER key of main lighting switch. Check for voltage. Press ALL OFF key and ENTER key of main lighting switch and turn MASTER switch off. If voltage is present, go to step 5. If voltage is not present, go to step 6.

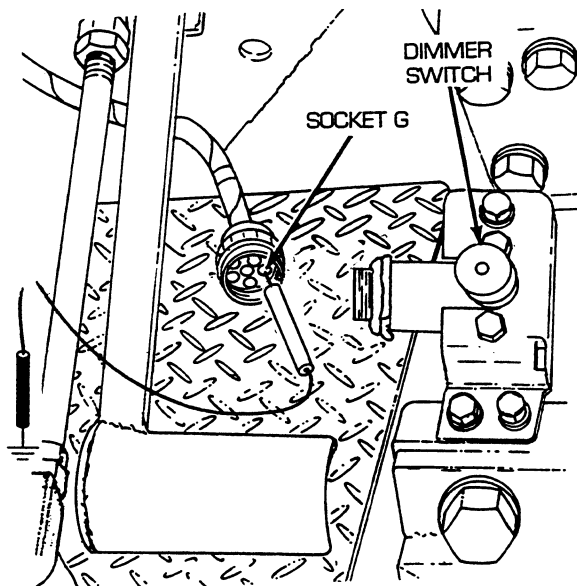

5. Reconnect headlight base assembly to headlight assembly. Disconnect headlight and dimmer switch wiring harness from dimmer switch. Place a jumper wire from socket C to pin C. Place red lead of multimeter on pin E of wire 18 and black lead to ground. Turn MASTER switch on, and press SER DRIVE key and ENTER key of main lighting switch. Check for voltage. Press ALL OFF key and ENTER key of main lighting switch and turn MASTER switch off. If voltage is present, go to step 8. If voltage is not present, replace dimmer switch (see WP 0174 00).

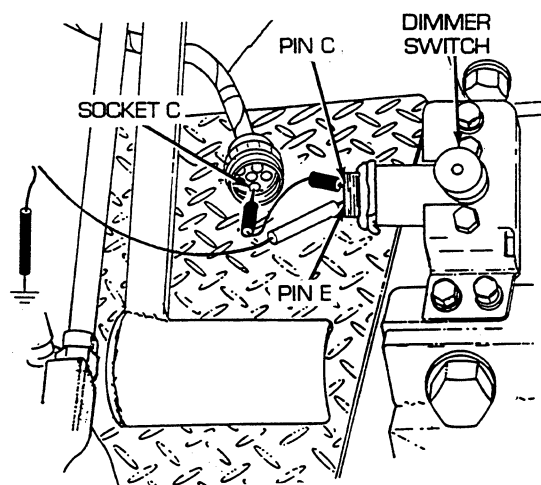

CORRECTIVE ACTION –Continued

6. Reconnect headlight and dimmer switch wiring harness to dimmer switch. Remove three screws (6), three lockwashers (7), ground wire (8), and flat washer (9) and release main switch panel (10) from mounting bracket. Disconnect switch panel to gage panel and miscellaneous switches wiring harness from main switch panel. Place red lead of multimeter on pin N of wire 10 and black lead to ground. Turn MASTER switch on and check for voltage. Turn MASTER switch OFF. If voltage is present, go to step 8. If voltage is not present, go to step 7.

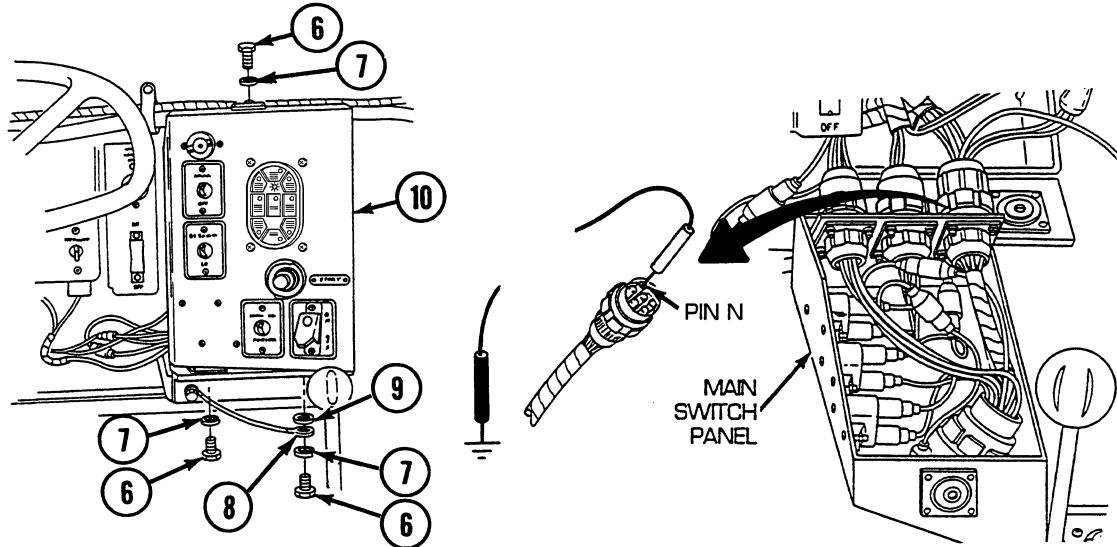

7. Open air inlet doors (TM 9-2350-256-10). Reconnect switch panel to gage panel and miscellaneous switches wiring harness to main switch panel. Disconnect wire 48 pin A from bulkhead to master relay wiring harness. Place red multimeter lead in socket A and black lead to ground. Turn MASTER switch on and check for voltage. If voltage is present, repair/replace switch panel, radio, and bilge pump to bulkhead wiring harness (see WP 0202 00). If voltage is not present, troubleshoot master relay circuit (see WP 0042 00).

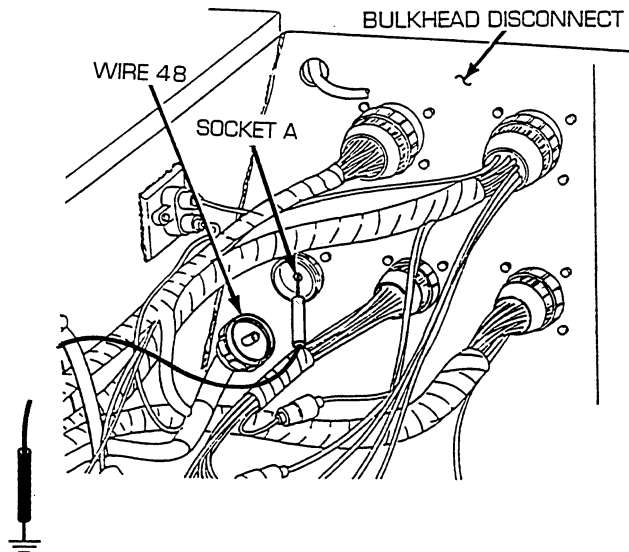

CORRECTIVE ACTION –Continued

8. Place a jumper wire from pin N to socket N. Place red lead of multimeter in socket B of wire 16 and black lead to ground. Turn MASTER switch on, UNLOCK and move main lighting switch in SER. DRIVE position, and check for voltage. Turn MASTER and main lighting switches OFF. If voltage is present, go to step 9. If voltage is not present, go to step 10.

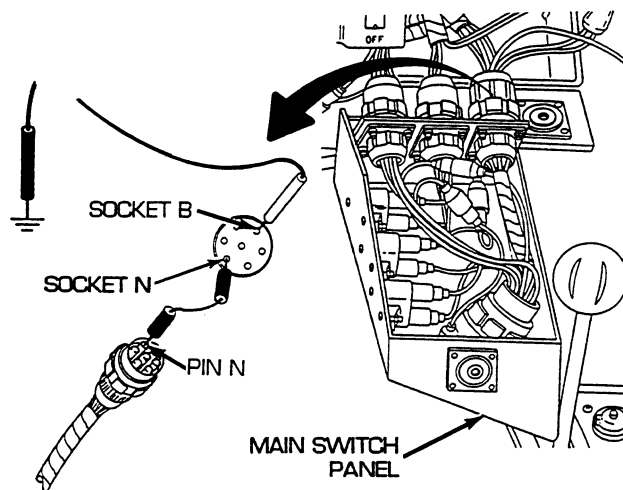

9. Reconnect switch panel to gage panel and miscellaneous switches wiring harness to main switch panel. Disconnect wire 16 of switch panel to gage panel and miscellaneous switches wiring harness from headlight and dimmer switch wiring harness. Place red lead of multimeter on male connector of wire 16 and black lead to ground. Turn MASTER switch on, UNLOCK and move main lighting switch in SER. DRIVE position, and auxiliary switch in any position other than PARK and check for voltage. Turn MASTER and main lighting switches OFF. If voltage is present, repair/replace wire 16 of headlight and dimmer switch wiring harness (see WP 0214 00). If voltage is not present, repair/replace wire 16 of switch panel to gage panel and miscellaneous switches wiring harness (see WP 0204 00 for dual voltage; 0205 00 for single voltage).

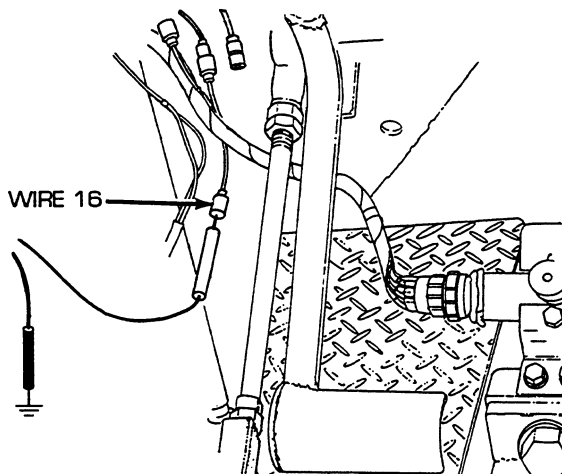

CORRECTIVE ACTION –Continued

10. Reconnect switch panel to gage panel and miscellaneous switches wiring harness to main switch panel. Disconnect main lighting and master relay wiring harness from main lighting switch. Place a jumper wire from pin F to socket F. Place red lead of multimeter on pin M of wire 16 and black lead to ground. Turn MASTER switch on, UNLOCK and place main lighting switch in SER. DRIVE position, and auxiliary switch in any position other than PARK, and check for voltage. Turn MASTER and main lighting switches OFF. If voltage is present, go to step 13. If voltage is not present, go to step 11.

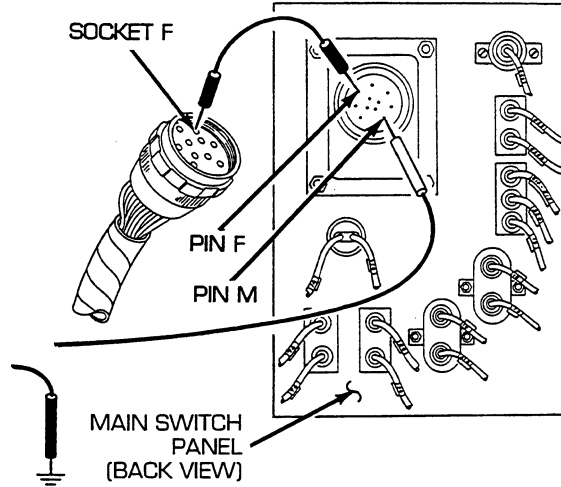

11. Reconnect main lighting and master relay wiring harness to main lighting switch. Disconnect wire 16 of main lighting and master relay wiring harness at connector. Place red lead of multimeter on male connector of wire 16 and black lead to ground. Turn MASTER switch on, UNLOCK and place main lighting switch in SER. DRIVE position, and auxiliary switch in any position other than PARK, and check for voltage. Turn MASTER and main lighting switches OFF. If voltage is present, repair/replace wire 16 of main lighting and B.O. selector switch wiring harness (see WP 0218 00). If voltage is not present, repair/replace wire 16 of main lighting and master relay wiring harness (see WP 0219 00).

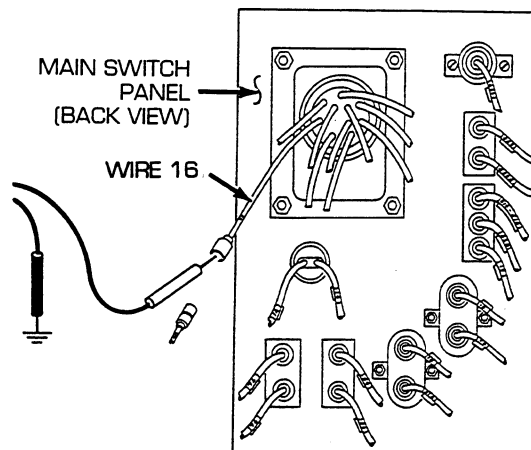

CORRECTIVE ACTION –Continued

12. Place red lead of multimeter in socket F of wire 15 and black lead to ground. Turn MASTER switch on and check for voltage. Turn MASTER switch OFF. If voltage is present, replace main lighting switch (see WP 0159 00). If voltage is not present, go to step 13.

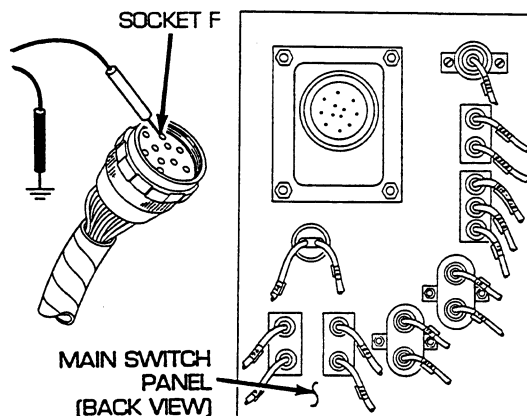

13. Reconnect main lighting and master relay wiring harness to main lighting switch. Disconnect wire 15 of main lighting and master relay wiring harness at connector. Place red lead of multimeter in female connector of wire 15 and black lead to ground. Turn MASTER switch on and check for voltage. Turn MASTER switch OFF. If voltage is present, repair/replace wire 15 of main lighting and master relay wiring harness (see WP 0219 00). If voltage is not present, repair/replace wire 10 of main lighting and B.O. selector switch wiring harness (see WP 0218 00).

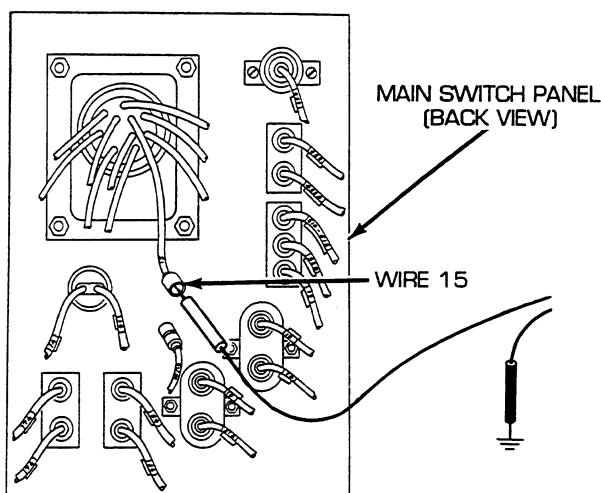

END OF WORK PACKAGE

UNIT MAINTENANCE
RECOVERY VEHICLE, FULL TRACKED: MEDIUM, M88A1
NSN 2350-00-122-6826, EIC AQA
HIGH BEAM INDICATOR TROUBLESHOOTING PROCEDURE

INITIAL SETUP:

Tools and Special Tools

Tool kit, general mechanic's (item 59, WP 0490 00)

References

WP 0182 00

WP 0214 00

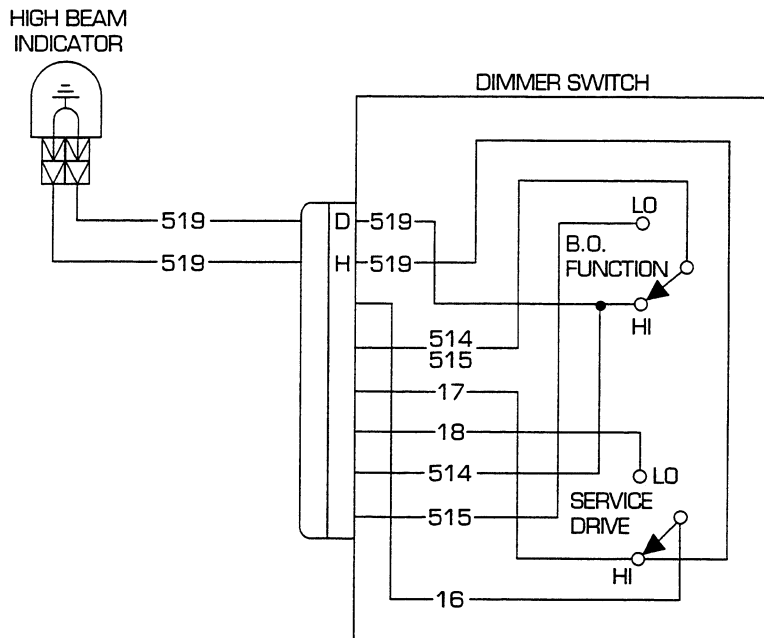
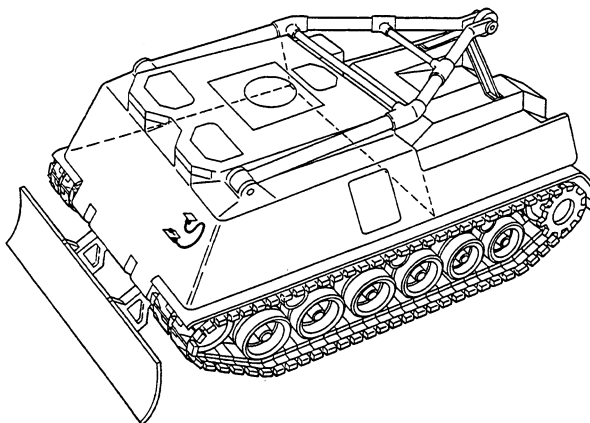

Troubleshooting Procedure

High Beam Indicator

Symptom

High beam indicator malfunctioning.

Malfunction

High beam indicator fails to light with high beams on, in IR or SER. DRIVE condition. Do steps 1 and 2.

CORRECTIVE ACTION

WARNING

Remove all jewelry such as rings, dog tags, bracelets, etc. If jewelry contacts a metal surface a direct short may result in instant heating of tools, damage to equipment, and injury or death to personnel.

1. Disconnect headlight and dimmer switch wiring harness from HIGH BEAM indicator light. Place red lead of multimeter in wire 519 (from pin D of dimmer switch) and black lead to ground. Turn MASTER switch on, press B.O. DRIVE key and ENTER key of main lighting switch, and B.O. SELECTOR switch in B.O. position, press dimmer switch, and check for voltage. Turn MASTER, main lighting, B.O. SELECTOR and dimmer switches OFF. If voltage is present, replace HIGH BEAM indicator light bulb (see WP 0182 00). If voltage is not present, go to step 2.
2. Place red lead of multimeter in wire 519 (from pin H of dimmer switch) and black lead to ground. Turn MASTER switch on, and press SER DRIVE key and ENTER key of main lighting switch, press dimmer switch, and check for voltage. Turn MASTER and main lighting and dimmer switches OFF. If voltage is present, replace HIGH BEAM indicator light bulb (see WP 0182 00). If voltage is not present, repair/replace wire 519 from pin H of headlight and dimmer switch wiring harness (see WP 0214 00).

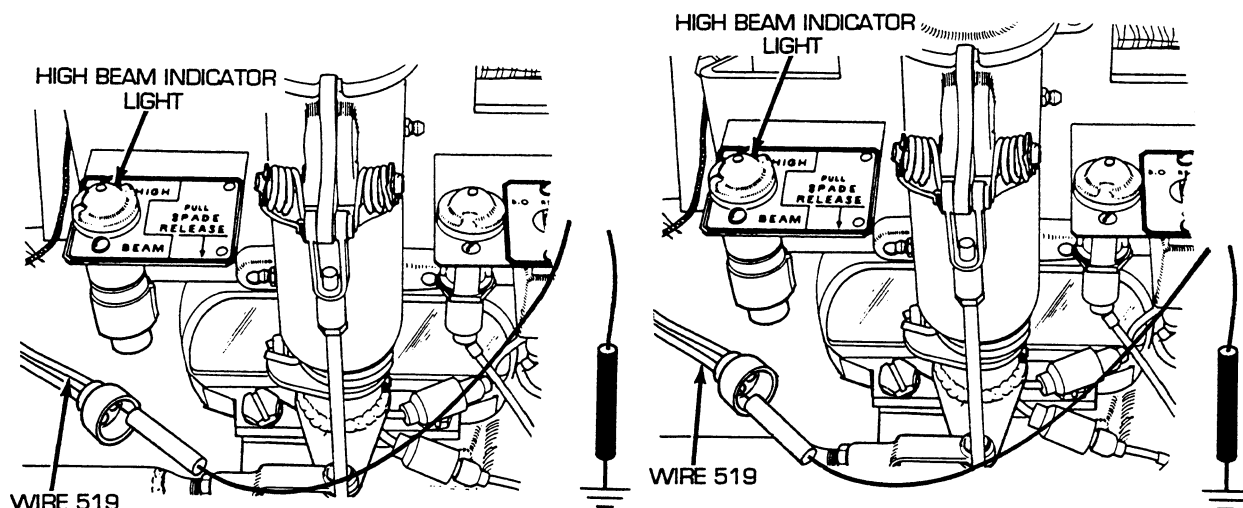

END OF WORK PACKAGE

UNIT MAINTENANCE
RECOVERY VEHICLE, FULL TRACKED: MEDIUM, M88A1
NSN 2350-00-122-6826, EIC AQA
SERVICE STOPLIGHT TROUBLESHOOTING PROCEDURE

INITIAL SETUP:**Tools and Special Tools**

Tool kit, general mechanic's (item 59, WP 0490 00)

References

WP 0042 00

WP 0159 00

WP 0172 00

WP 0179 00

References (cont.)

WP 0202 00

WP 0204 00

WP 0205 00

WP 0218 00

WP 0219 00

WP 0220 00

TM 9-2350-256-10

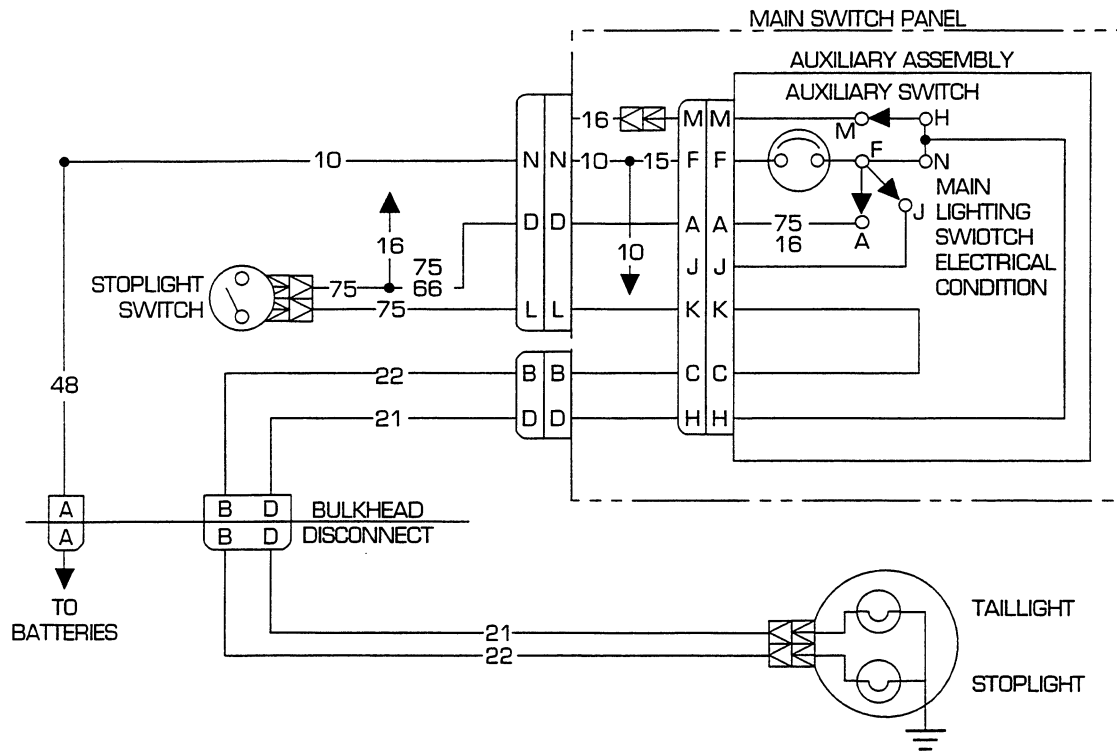
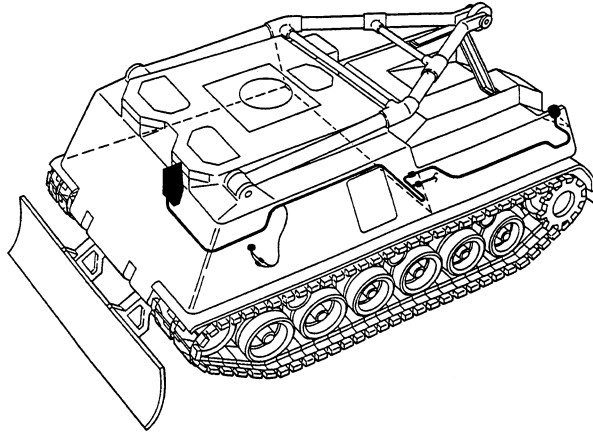

Troubleshooting Procedure

Service Stoplight

Symptom

Service stoplight malfunctioning.

Malfunction

Service stoplight fails to operate. Do steps 1 thru 11.

CORRECTIVE ACTION

WARNING

Remove all jewelry such as rings, dog tags, bracelets, etc. If jewelry contacts a metal surface a direct short may result in instant heating of tools, damage to equipment, and injury or death to personnel.

1. Loosen six screws (1) and remove stoplight cover (2). Remove stoplight lamp (3). Place red lead of multimeter in socket and black lead to ground. Turn MASTER switch on, and press SER DRIVE key and ENTER key of main lighting switch. Depress stoplight switch (vehicle brake) and check for voltage. Turn MASTER, main lighting, and stoplight switches OFF. If voltage is present, replace lamp (see WP 0179 00). If voltage is not present, go to step 2.

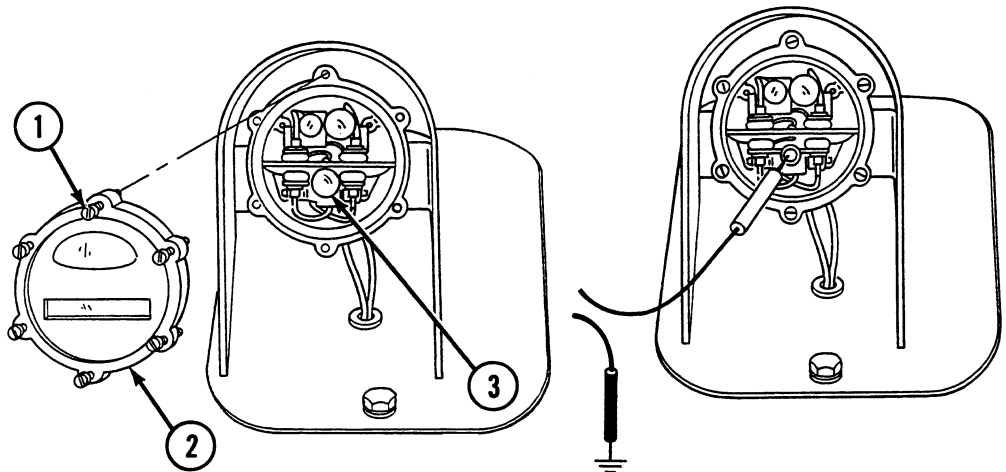

CORRECTIVE ACTION –Continued

2. Install stoplight lamp (3), stoplight cover (2), and tighten six screws (1). Remove two screws (4), two lockwashers (5), and hydraulic access plate (6). Disconnect wire 22 of bulkhead to master relay and left and right taillight wiring harness from left taillight assembly. Place red lead of multimeter in wire 22 and black lead to ground. Turn MASTER switch on, and press SER DRIVE key and ENTER key, depress stoplight switch (vehicle brake) and check for voltage. Turn MASTER, main lighting, and stoplight switches OFF. If voltage is present, replace taillight lamp (see WP 0179 00). If voltage is not present, go to step 3.

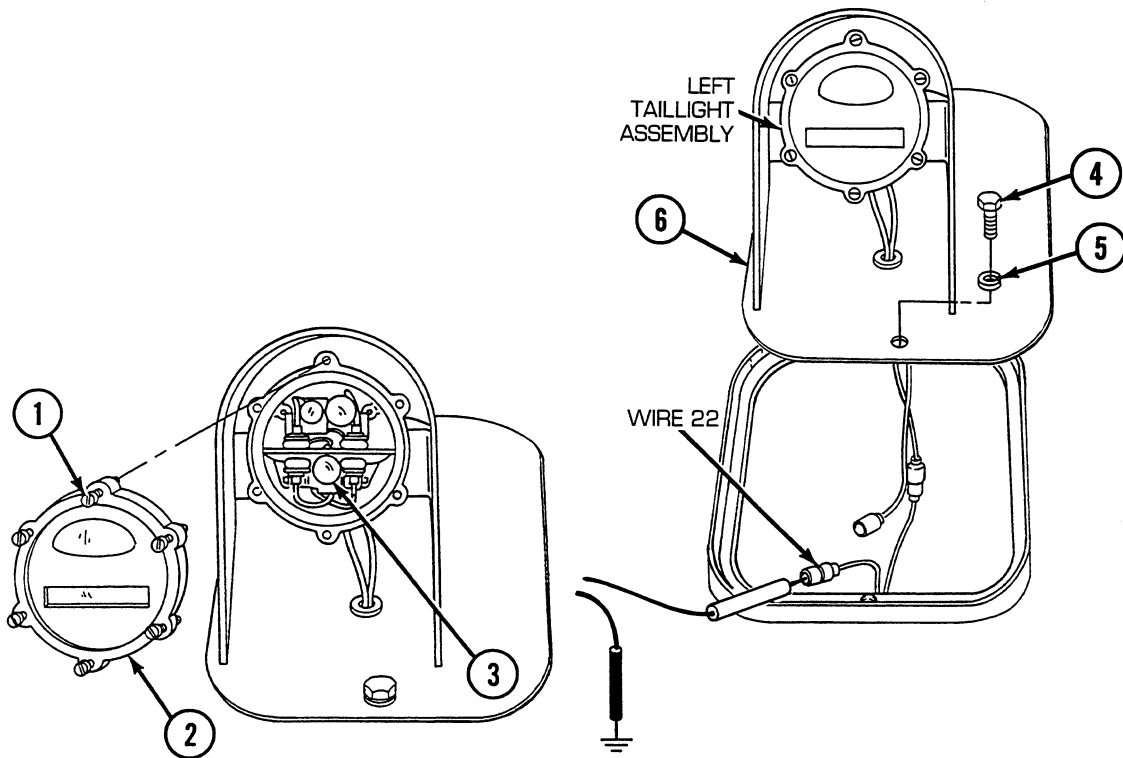

CORRECTIVE ACTION –Continued

- Open air inlet doors (TM 9-2350-256-10). Reconnect wire 22 at bulkhead to master relay and left and right taillight wiring harness to left taillight assembly. Install hydraulic access plate (6), two lockwashers (5), and two screws (4). Disconnect bulkhead to master relay and left and right taillight wiring harness from bulkhead disconnect. Place red lead of multimeter in socket B of wire 22 and black lead to ground. Turn MASTER switch on, and press SER DRIVE key and ENTER key of main lighting switch, and depress stoplight switch, and check for voltage. Turn MASTER and main lighting switches OFF. If voltage is present, repair/replace wire 22 of bulkhead to master relay and left and right taillight wiring harness (see WP 0220 00). If voltage is not present, go to step 4.

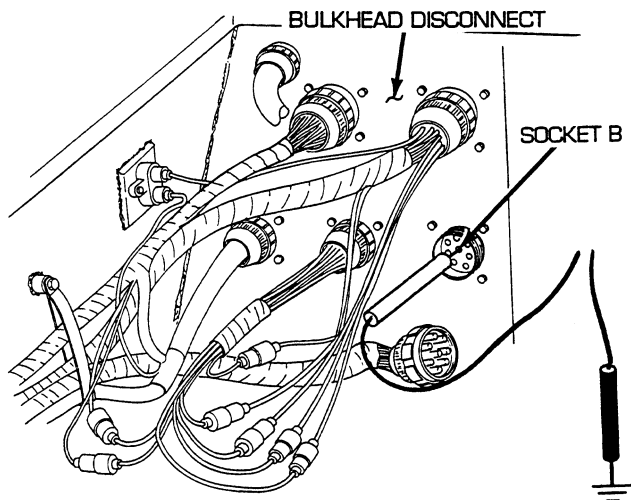

- Remove three screws (7), three lockwashers (8), ground lead (9), and flat washer (10) and release main switch panel (11) from mounting brackets. Reconnect bulkhead to master relay and left and right taillight wiring harness to bulkhead disconnect. Disconnect switch panel to gage panel and miscellaneous switches wiring harness from main switch panel. Place red lead of multimeter on pin N of wire 10 and black lead to ground. Turn MASTER switch on and check for voltage. Turn MASTER switch OFF. If voltage is present, go to step 5. If voltage is not present, go to step 11.

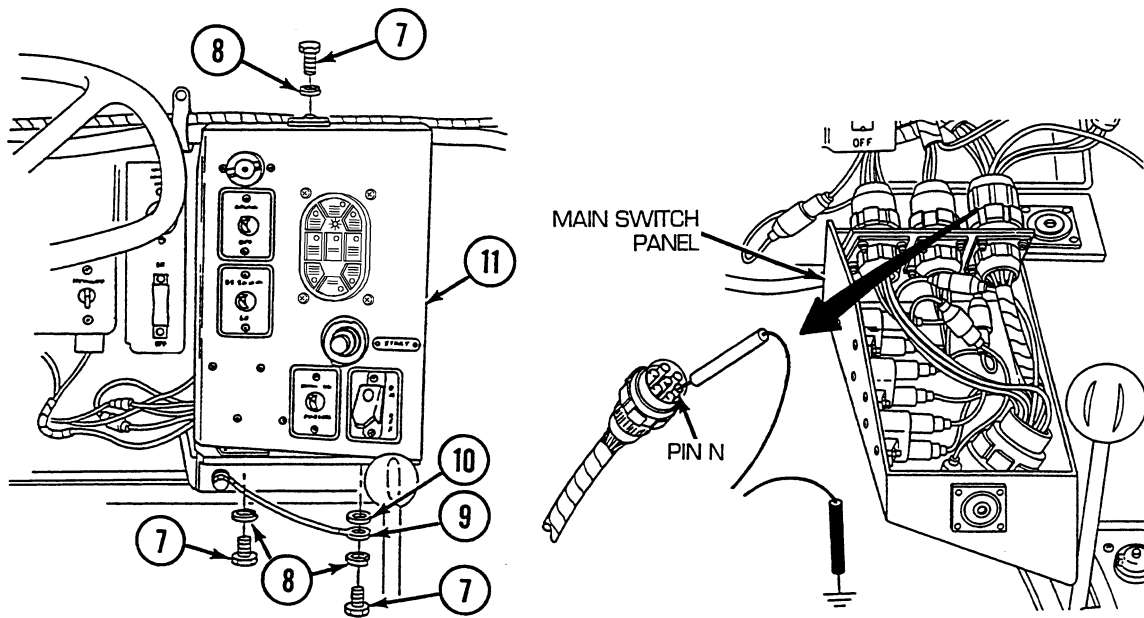

CORRECTIVE ACTION –Continued

5. Place red lead of multimeter on pin D of wire 75/16 and black lead on pin L of wire 75. Check for continuity. If continuity is present, go to step 6. If continuity is not present, go to step 9.

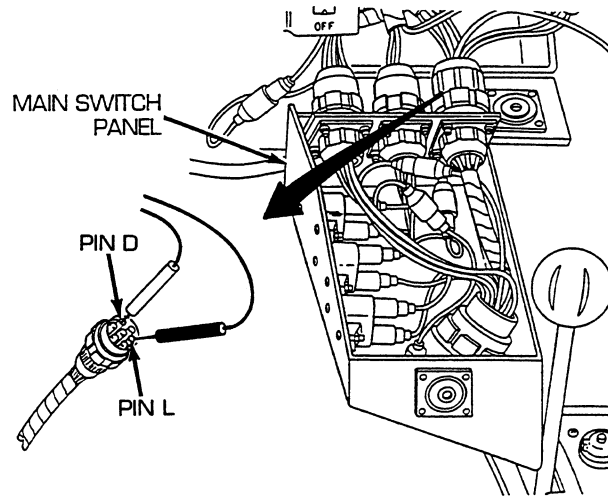

6. Reconnect switch panel to gage panel and miscellaneous switches wiring harness to main switch panel. Disconnect main lighting and master relay wiring harness from main lighting switch. Place red lead of multimeter on pin C and black lead on pin K. Check for continuity. If continuity is present, go to step 7. If continuity is not present, replace main lighting switch (see WP 0159 00).

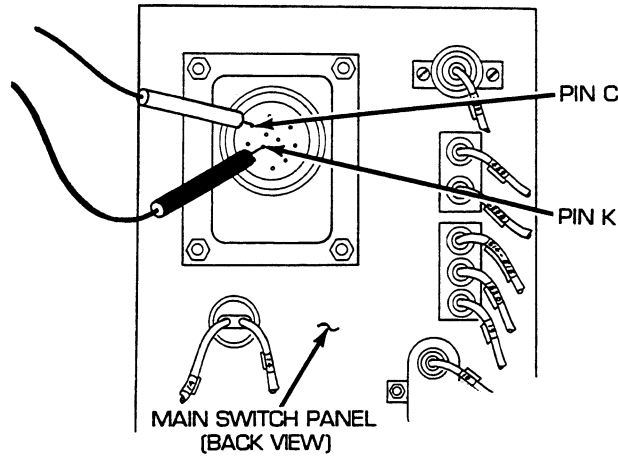

CORRECTIVE ACTION –Continued

7. Place red lead of multimeter on pin A and black lead on pin F. Check for continuity. If continuity is present, go to step 8. If continuity is not present, replace main lighting switch (see WP 0159 00).

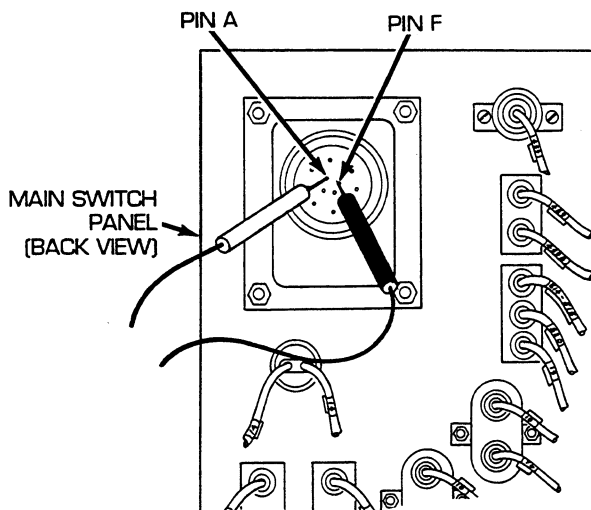

8. Reconnect main lighting and master relay wiring harness to main lighting switch. Disconnect wire 75 of main lighting and B.O. selector switch wiring harness at connector. Place red lead of multimeter in female connector of wire 75 and black lead to ground. Turn MASTER switch on, press SER DRIVE key and ENTER key of main lighting switch, depress stoplight switch, and check for voltage. Turn MASTER, stoplight, and main lighting switches OFF. If voltage is present, repair/replace wire 75 of main lighting and B.O. selector switch wiring harness (see WP 0218 00). If voltage is not present, repair/replace wire 75 of main lighting and master relay wiring harness (see WP 0219 00).

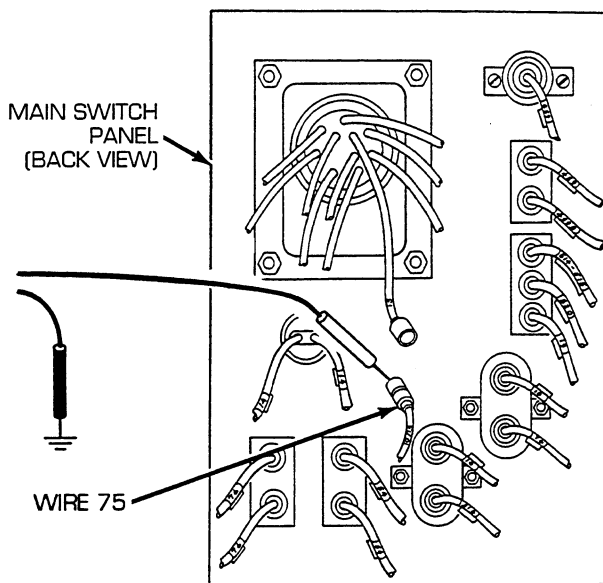

CORRECTIVE ACTION –Continued

9. Install main switch panel (11), flat washer (10), ground lead (9), three lockwashers (8), and three screws (7). Reconnect switch panel to gage panel and miscellaneous switches wiring harness to main switch panel. Disconnect wire 75/16 at stoplight switch. Place red lead of multimeter in wire 75/16 and black lead to ground. Turn MASTER switch on, press SER DRIVE key and ENTER key of main lighting switch, and check for voltage. Turn MASTER and main lighting switches OFF. If voltage is present, go to step 10. If voltage is not present, repair/replace wire 75/16 of switch panel to gage panel and miscellaneous switches wiring harness (see WP 0204 00 for dual voltage; 0205 00 for single voltage).

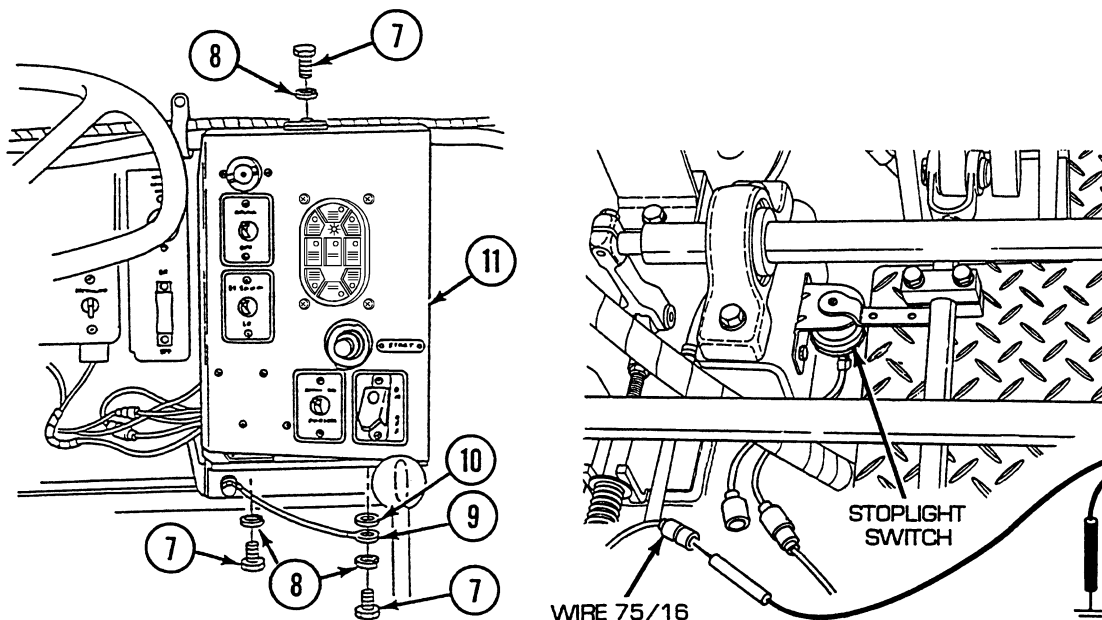

10. Reconnect wire 75/16 to stoplight switch. Disconnect wire 75 from stoplight switch. Place red lead of multimeter on wire 75 of stoplight switch and black lead to ground. Turn MASTER switch on, UNLOCK and place main lighting switch in SER. DRIVE position, depress stoplight switch, and check for voltage. Turn MASTER, main lighting, and stoplight switches OFF. If voltage is present, repair/replace wire 75 of switch panel to gage panel and miscellaneous switches wiring harness (see WP 0204 00 for dual voltage; 0205 00 for single voltage). If voltage is not present, replace stoplight switch (see WP 0172 00).

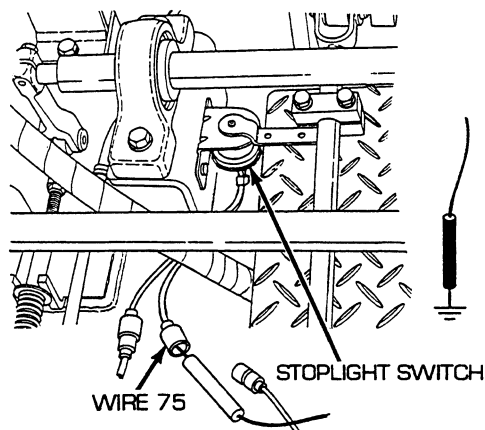

CORRECTIVE ACTION –Continued

11. Reconnect switch panel to gage panel and miscellaneous switches wiring harness to main switch panel. Install main switch panel (11), flat washer (10), ground lead (9), three lockwashers (8), and three screws (7). Open air inlet doors. Disconnect wire 48 pin A from bulkhead to master relay wiring harness. Place red multimeter lead in socket and black lead to ground. Turn MASTER switch on and check for voltage. If voltage is present, repair/replace switch panel, radio, and bilge pump to bulkhead wiring harness (see WP 0202 00). If voltage is not present, troubleshoot master relay circuit (see WP 0042 00).

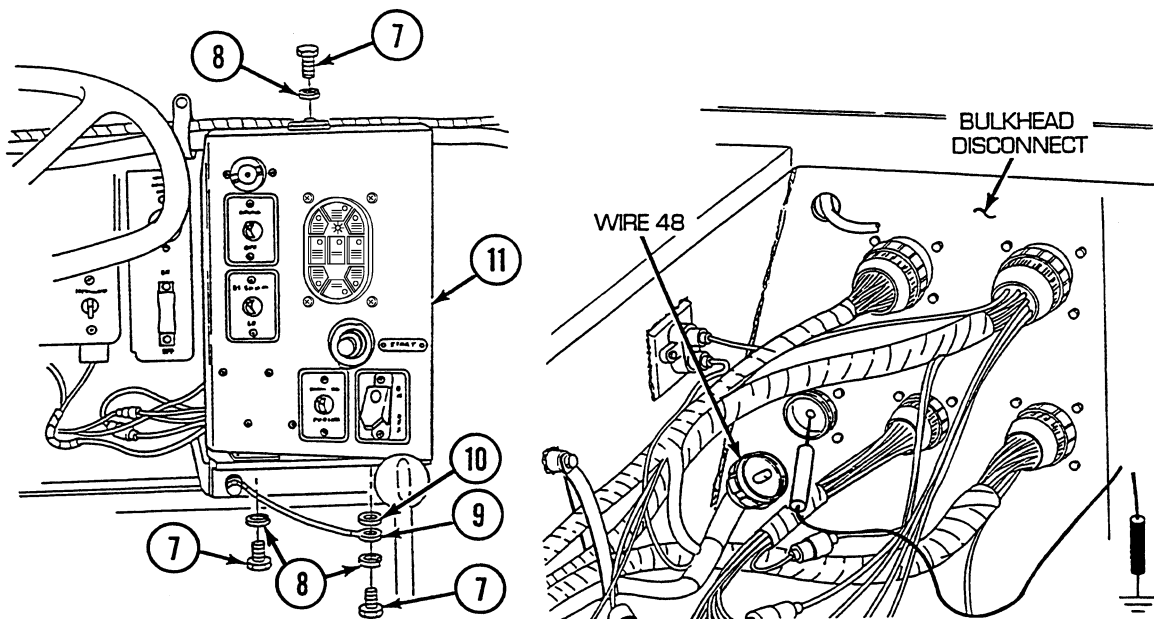
**END OF WORK PACKAGE**

UNIT MAINTENANCE
RECOVERY VEHICLE, FULL TRACKED: MEDIUM, M88A1
NSN 2350-00-122-6826, EIC AQA

B.O. SERVICE CONDITION (IR HEADLIGHTS) TROUBLESHOOTING PROCEDURE

INITIAL SETUP:

Tools and Special Tools

Tool kit, general mechanic's (item 59, WP 0490 00)

References

WP 0042 00
WP 0159 00
WP 0174 00
WP 0175 00
WP 0202 00

References (cont.)

WP 0204 00
WP 0205 00
WP 0213 00
WP 0214 00
WP 0217 00
WP 0218 00
WP 0219 00
TM 9-2350-256-10

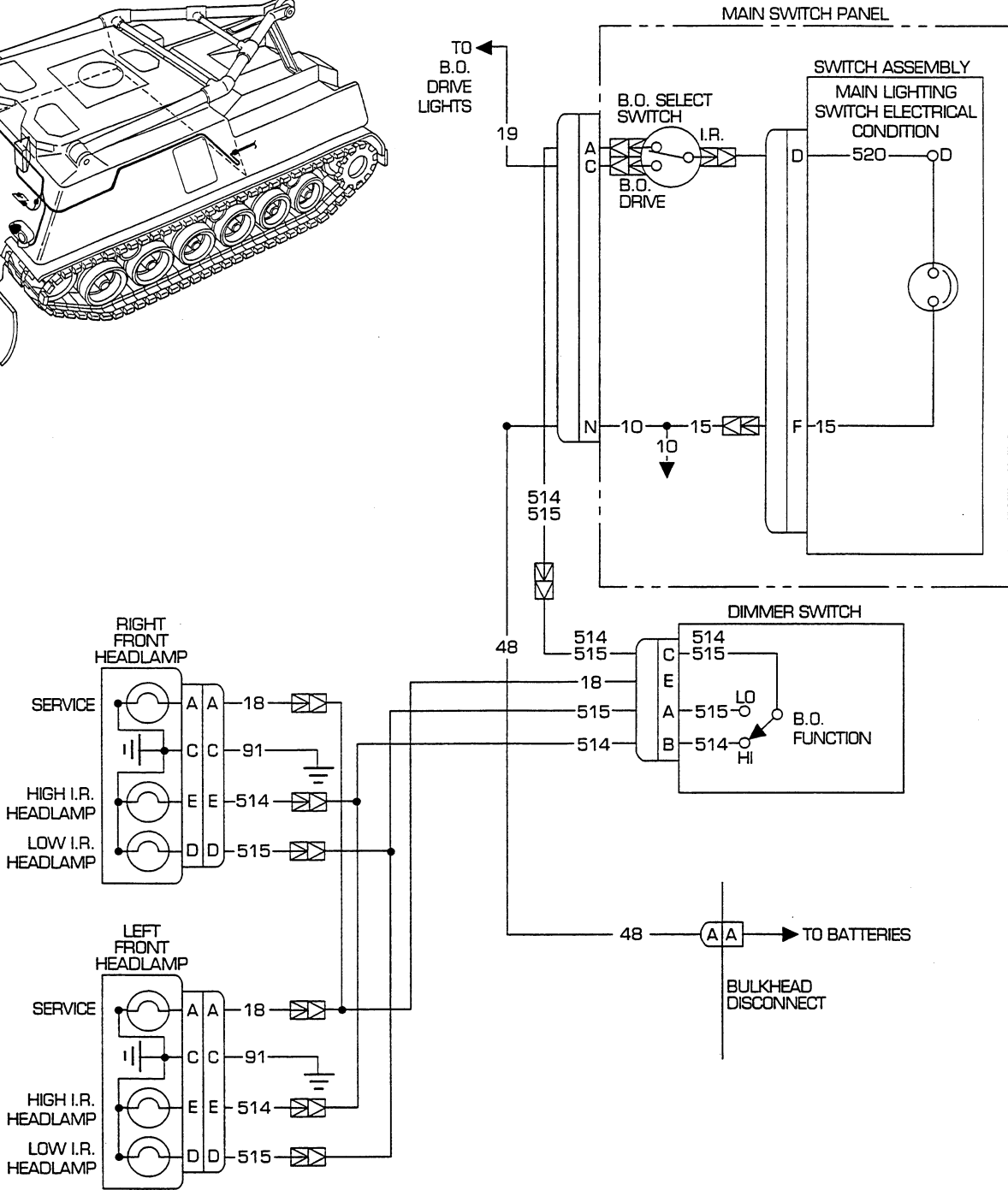
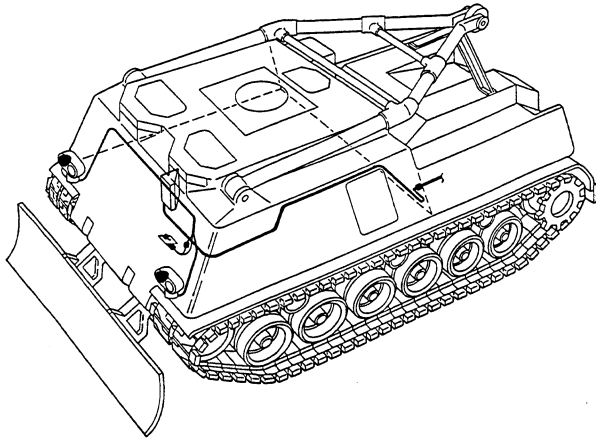

Troubleshooting Procedure**B.O. Service Condition (IR Headlights)****Symptom**

IR headlights malfunctioning

Malfunction

IR headlights fail to operate. Do steps 1 thru 19.

CORRECTIVE ACTION**WARNING**

Remove all jewelry such as rings, dog tags, bracelets, etc. If jewelry contacts a metal surface a direct short may result in instant heating of tools, damage to equipment, and injury or death to personnel.

1. Loosen four screws (1) and remove headlight cover (2). Remove lamp (3) and disconnect connector. Place red lead of multimeter in socket A of wire 18. Turn MASTER switch ON, press B.O. DRIVE key and ENTER key of main light switch, place B.O. SELECTOR switch to IR and check for voltage. Turn MASTER and main lighting switches OFF. If voltage is present, replace lamp. If voltage is not present, go to step 2.

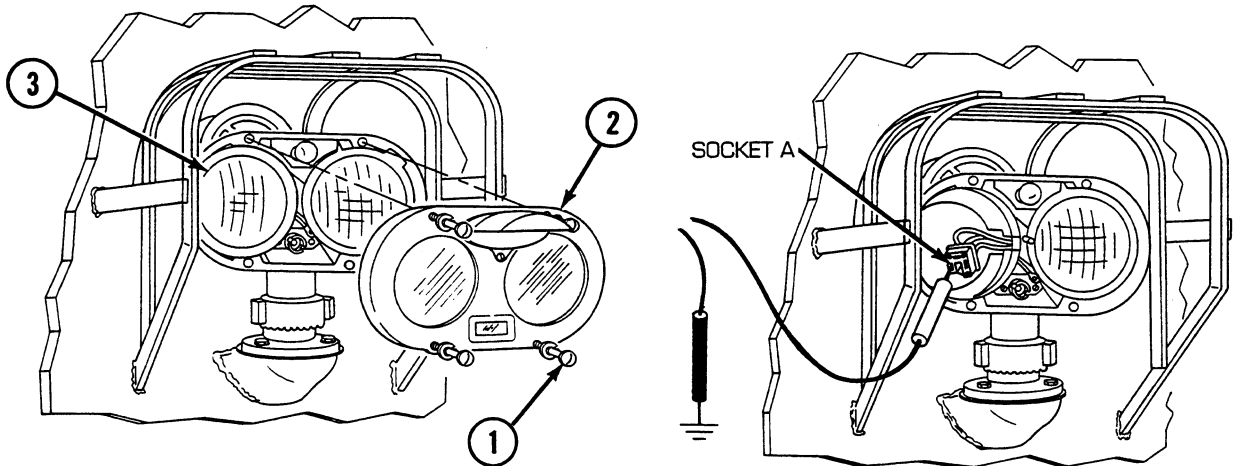

CORRECTIVE ACTION –Continued

2. Install lamp (3), headlight cover (2), and tighten four screws (1). Loosen adjustment nut (4) and remove headlight assembly (5). Place red lead of multimeter in socket D of wire 515 and black lead to ground. Turn MASTER switch ON, press B.O. DRIVE key and ENTER key of main light switch, place B.O. SELECTOR switch to IR and check for voltage. Turn MASTER, main lighting, and B.O. SELECTOR switches off. If voltage is present, go to step 3. If voltage is not present, go to step 5.

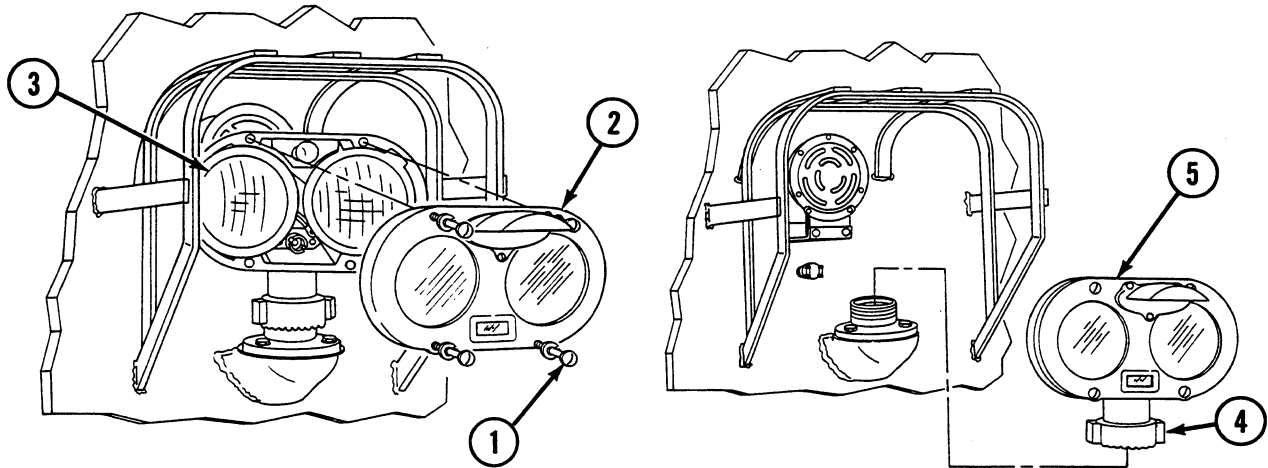

3. Place red lead of multimeter in socket E of wire 514 and black lead to ground. Turn MASTER switch on, press B.O. DRIVE key and ENTER key of mainlight switch, place B.O. SELECTOR switch to IR, press dimmer switch, and check for voltage. Turn MASTER, main lighting, B.O. SELECTOR, and dimmer switches OFF. If voltage is present, go to step 4. If voltage is not present, go to step 5.

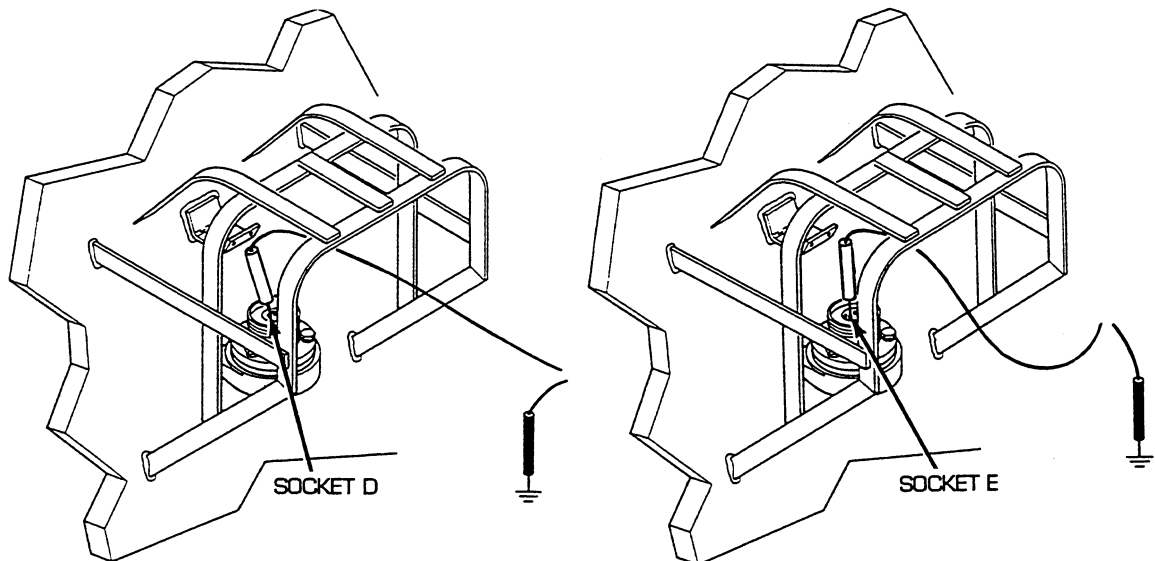

CORRECTIVE ACTION –Continued

4. Place red lead of multimeter in socket C of wire 91 (ground) and black lead to ground. Check for continuity. If continuity is present, replace head lamp (see WP 0175 00). If continuity is not present, repair/replace wire 91 (ground) of headlight and dimmer switch wiring harness (see WP 0214 00).

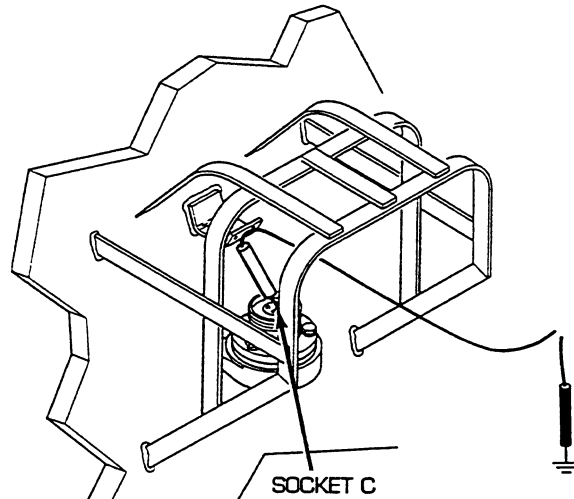

5. Reconnect headlight base assembly to headlight assembly. Disconnect headlight and dimmer switch wiring harness from dimmer switch. Place a jumper wire from socket C to pin C of wire 514/515. Place red lead of multimeter on pin A of wire 515 and black lead to ground. Turn MASTER switch on, press B.O. DRIVE key and ENTER key of main light switch, place B.O. SELECTOR to IR, and check voltage. Turn MASTER, main lighting, and B.O. SELECTOR switches off. If voltage is present, go to step 7. If voltage is not present, go to step 6.

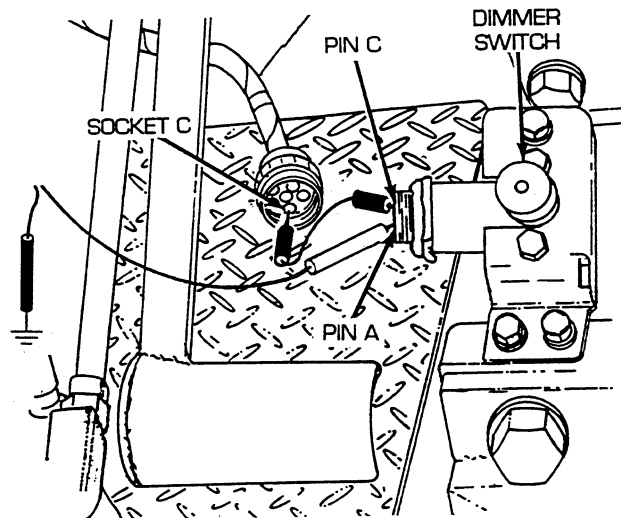

CORRECTIVE ACTION –Continued

6. Place a jumper wire from socket C to pin C of wire 514/515. Place red lead of multimeter on pin B of wire 514 and black lead to ground. Turn MASTER switch on, press B.O. DRIVE key and ENTER key of main light switch, place B.O. SELECTOR switch to IR, press dimmer switch, and check for voltage. Turn MASTER, main lighting, B.O. SELECTOR, and dimmer switches off. If voltage is present, go to step 8. If voltage is not present, go to step 9.

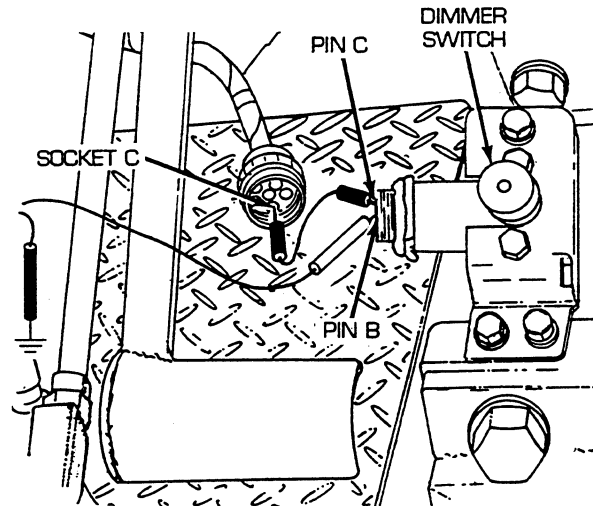

7. Reconnect headlight and dimmer switch wiring harness to dimmer switch. Disconnect wire 515 of headlight base assembly at connector. Place red lead of multimeter in wire 515 and black lead to ground. Turn MASTER switch on, press B.O. DRIVE key and ENTER key of main light switch, place B.O. SELECTOR switch to IR, and check for voltage. Turn MASTER, main lighting, and B.O. SELECTOR switches off. If voltage is present, repair/replace wire 515 of headlight base wiring harness (see WP 0213 00). If voltage is not present, repair/replace wire 515 of headlight and dimmer switch wiring harness (see WP 0214 00).

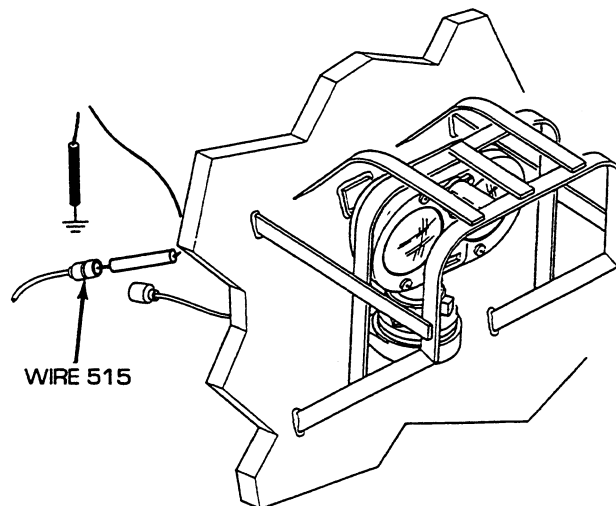

CORRECTIVE ACTION –Continued

8. Reconnect headlight and dimmer switch wiring harness to dimmer switch. Disconnect wire 514 of headlight base assembly at connector. Place red lead of multimeter in wire 514 and black lead to ground. Turn MASTER switch on, press B.O. DRIVE key and ENTER key of main light switch, place B.O. SELECTOR switch to IR, press dimmer switch, and check voltage. Turn MASTER, main lighting, B.O. SELECTOR, and dimmer switches off. If voltage is present, repair/replace wire 514 of headlight base wiring harness (see WP 0213 00). If voltage is not present, repair/replace wire 514 of headlight and dimmer switch wiring harness (see WP 0214 00).

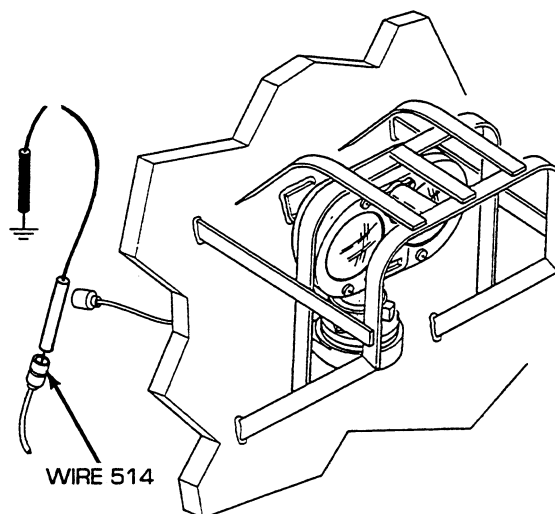

9. Place red lead of multimeter in socket C of wire 514/515 and black lead to ground. Turn MASTER switch on, press B.O. DRIVE key and ENTER key of main light switch, place B.O. SELECTOR switch to IR, and check for voltage. Turn MASTER, main lighting, and B.O. SELECTOR switches off. If voltage is present, replace dimmer switch (see WP 0174 00). If voltage is not present, go to step 10.

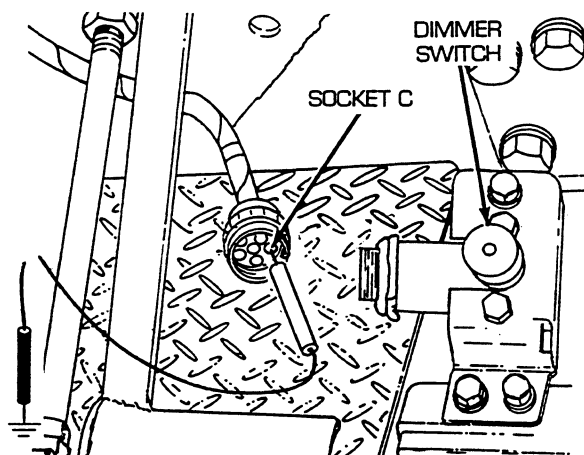

CORRECTIVE ACTION –Continued

10. Reconnect headlight and dimmer switch wiring harness to dimmer switch. Remove three screws (6), three lockwashers (7), ground lead (8), and flat washer (9) and release main switch panel (10) from mounting brackets. Disconnect switch panel to gage panel and miscellaneous switches wiring harness from main switch panel. Place red lead of multimeter on pin N of wire 10 and black lead to ground. Turn MASTER switch on and check for voltage. Turn MASTER switch OFF. If voltage is present, go to step 11. If voltage is not present, go to step 19.

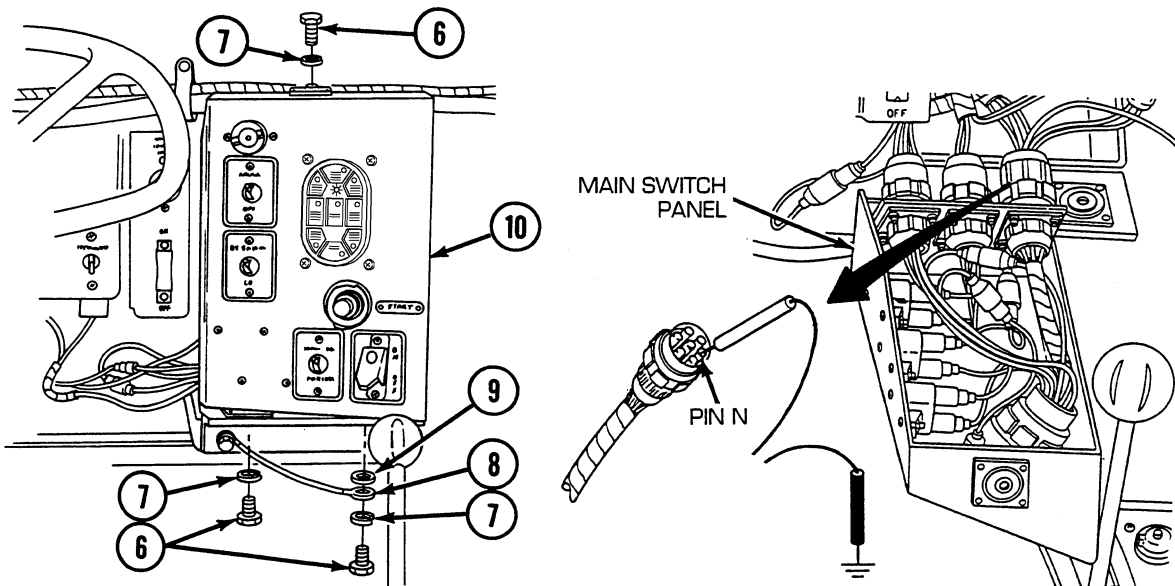

11. Place a jumper wire from pin N to socket N of wire 10. Place red lead of multimeter in socket A of wire 514/515 and black lead to ground. Turn MASTER switch ON, press B.O. DRIVE key and ENTER key of main light switch, place B.O. SELECTOR switch to IR and check for voltage. Turn MASTER main lighting, and B.O. SELECTOR switches off. If voltage is present, go to step 12. If voltage is not present, go to step 13.

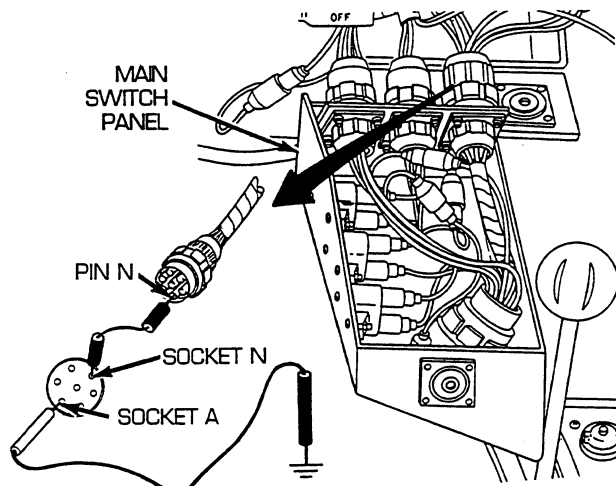

12. Reconnect switch panel to gage panel and miscellaneous switches wiring harness to main switch panel. Install main switch panel (10), flat washer (9), ground lead (8), three lockwashers (7), and

CORRECTIVE ACTION –Continued

three screws (6) to mounting bracket. Disconnect wire 514/515 of switch panel to gage panel and miscellaneous switches wiring harness from headlight and dimmer switch wiring harness. Place red lead of multimeter on male connector of wire 514/515 and black lead to ground. Turn MASTER switch on, press B.O. DRIVE key and ENTER key of main light switch, place B.O. SELECTOR switch to IR, and check for voltage. Turn MASTER, main lighting, and B.O. SELECTOR switches off. If voltage is present, repair/replace wire 514/515 of headlight and dimmer switch wiring harness (see WP 0214 00). If voltage is not present, repair/replace wire 514/515 of switch panel to gage panel and miscellaneous switches wiring harness (see WP 0204 00 for dual voltage; 0205 00 for single voltage).

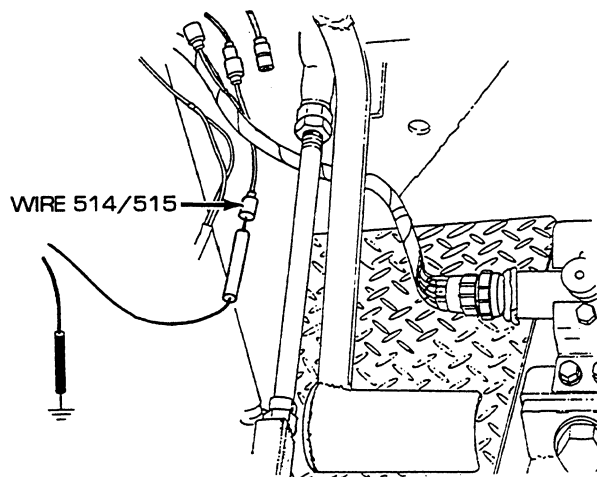

13. Reconnect switch panel to gage panel and miscellaneous switches wiring harness to main switch panel. Disconnect wire 514/515 from B.O. SELECTOR switch. Place red lead of multimeter on terminal of switch and black lead to ground. Turn MASTER switch on, press B.O. DRIVE key and ENTER key of main light switch, place B.O. SELECTOR switch to IR, and check for voltage. If voltage is present, repair/replace wire 514/515 of main lighting and B.O. selector switch wiring harness (see WP 0218 00). If voltage is not present, go to step 14.

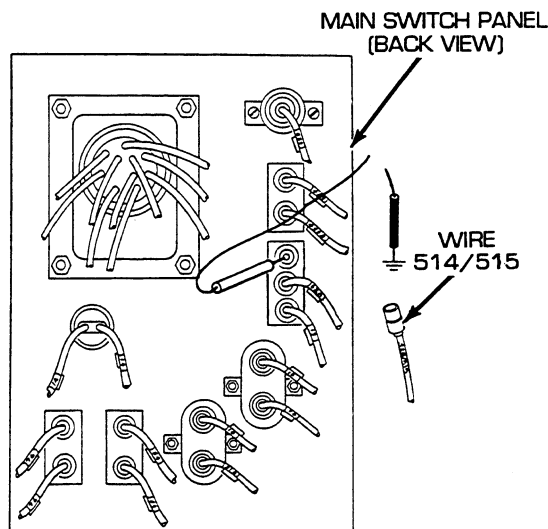

CORRECTIVE ACTION –Continued

14. Reconnect wire 514/515 to B.O. SELECTOR switch. Disconnect wire 520 from B.O. SELECTOR switch. Place red lead of multimeter in wire 520 and black lead to ground. Turn MASTER switch ON, press B.O. DRIVE key and ENTER key of main light switch, and check voltage. Turn MASTER and main lighting switches OFF. If voltage is present, replace B.O. SELECTOR switch (see WP 0159 00). If voltage is not present, go to step 15.

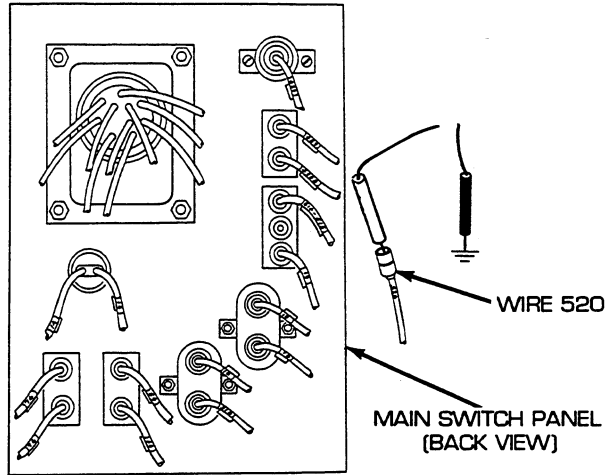

15. Reconnect wire 520 to B.O. SELECTOR switch. Disconnect main lighting and master relay wiring harness from main lighting switch. Place a jumper wire from pin F to socket F. Place red lead of multimeter on pin D of wire 520 and black lead to ground. Turn MASTER switch ON, press B.O. DRIVE key and ENTER key of main light switch, and check for voltage. Turn MASTER and main lighting switches OFF. If voltage is present, go to step 16. If voltage is not present, go to step 17.

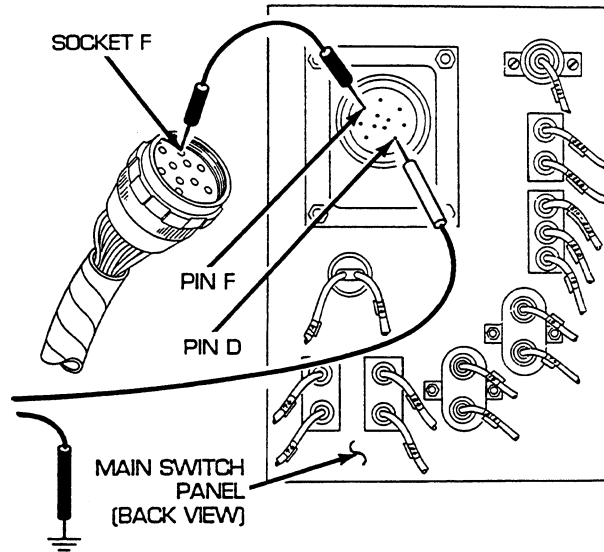

CORRECTIVE ACTION –Continued

16. Reconnect main lighting and master relay wiring harness to main lighting switch. Disconnect wire 520 at female connector, near main lighting switch. Place red lead of multimeter in female connector of wire 520 and black lead to ground. Turn MASTER switch ON, press B.O. DRIVE key and ENTER key of main light switch, and check for voltage. Turn MASTER and main lighting switches OFF. If voltage is present, repair/replace wire 520 of B.O. selector lead assembly (see WP 0217 00). If voltage is not present, repair/replace wire 520 of main lighting and master relay wiring harness (see WP 0219 00).

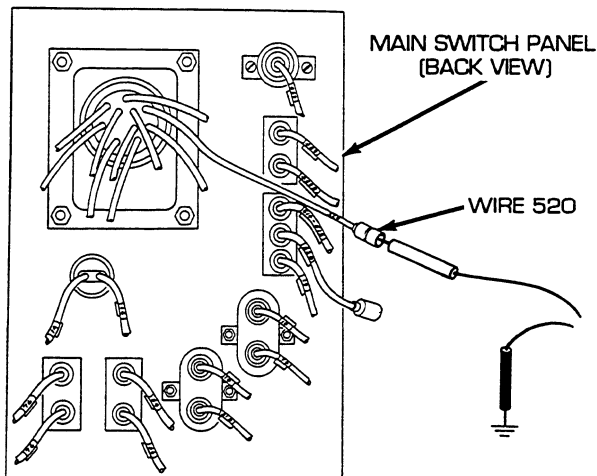

17. Place red lead of multimeter in socket F of wire 15 and black lead to ground. Turn MASTER switch on and check for voltage. Turn MASTER switch OFF. If voltage is present, replace main lighting switch (see WP 0159 00). If voltage is not present, go to step 18.

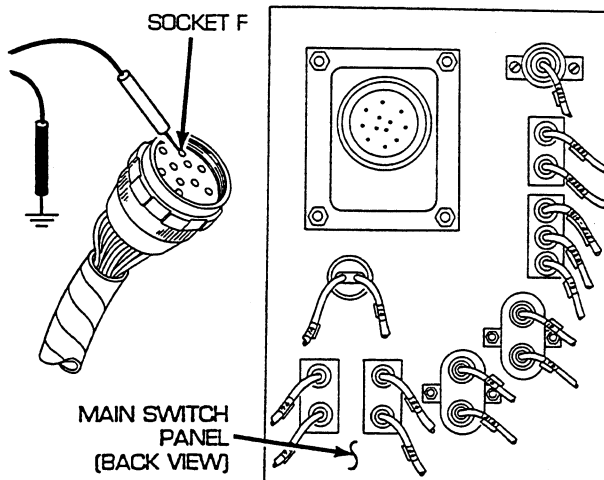

CORRECTIVE ACTION –Continued

18. Reconnect main lighting and master relay wiring harness to main lighting switch. Disconnect wire 15 of main lighting and master relay wiring harness at connector. Place red lead of multimeter in female connector of wire 15 and black lead to ground. Turn MASTER switch on and check for voltage. Turn MASTER switch OFF. If voltage is present, repair/replace wire 15 of main lighting and master relay wiring harness (see WP 0219 00). If voltage is not present, repair/replace wire 10 of main lighting and B.O. selector switch wiring harness (see WP 0218 00).

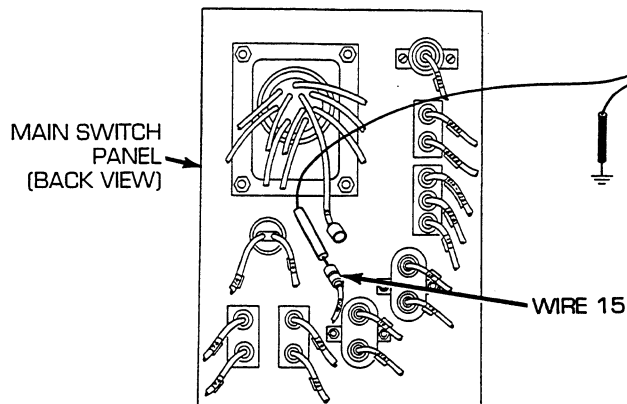

19. Reconnect switch panel to gage panel and miscellaneous switches wiring harness to main switch panel. Install main switch panel (10), flat washer (9), ground lead (8), three lockwashers (7), and three screws (6). Open air inlet doors (TM 9-2350-256-10). Disconnect wire 48 pin A from bulkhead to master relay wiring harness. Place red multimeter lead in socket and black lead to ground. Turn MASTER switch on and check for voltage. If voltage is present, repair/replace switch panel, radio, and bilge pump to bulkhead wiring harness (see WP 0202 00). If voltage is not present, troubleshoot master relay circuit (see WP 0042 00).

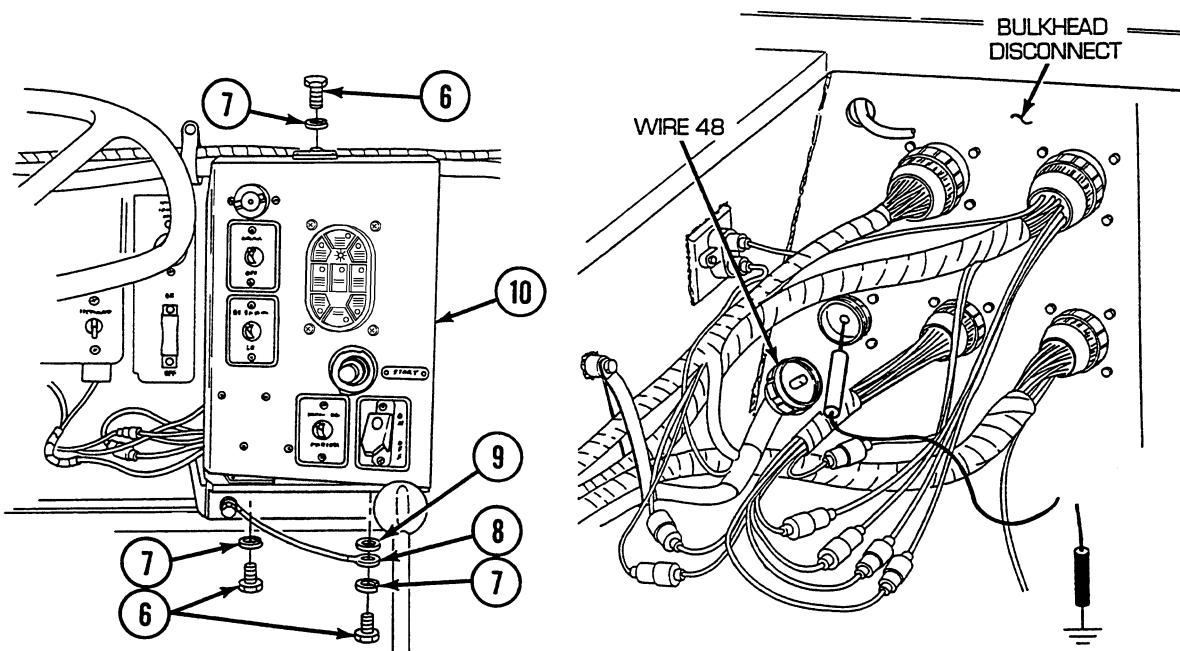

END OF WORK PACKAGE

UNIT MAINTENANCE
RECOVERY VEHICLE, FULL TRACKED: MEDIUM, M88A1
NSN 2350-00-122-6826, EIC AQA

B.O. SERVICE CONDITION (B.O. STOPLIGHT) TROUBLESHOOTING PROCEDURE

INITIAL SETUP:

Tools and Special Tools

Tool kit, general mechanic's (item 59, WP 0490 00)

References

- WP 0042 00
- WP 0159 00
- WP 0172 00
- WP 0179 00

References (cont.)

- WP 0202 00
- WP 0204 00
- WP 0205 00
- WP 0218 00
- WP 0219 00
- WP 0220 00
- TM 9-2350-256-10

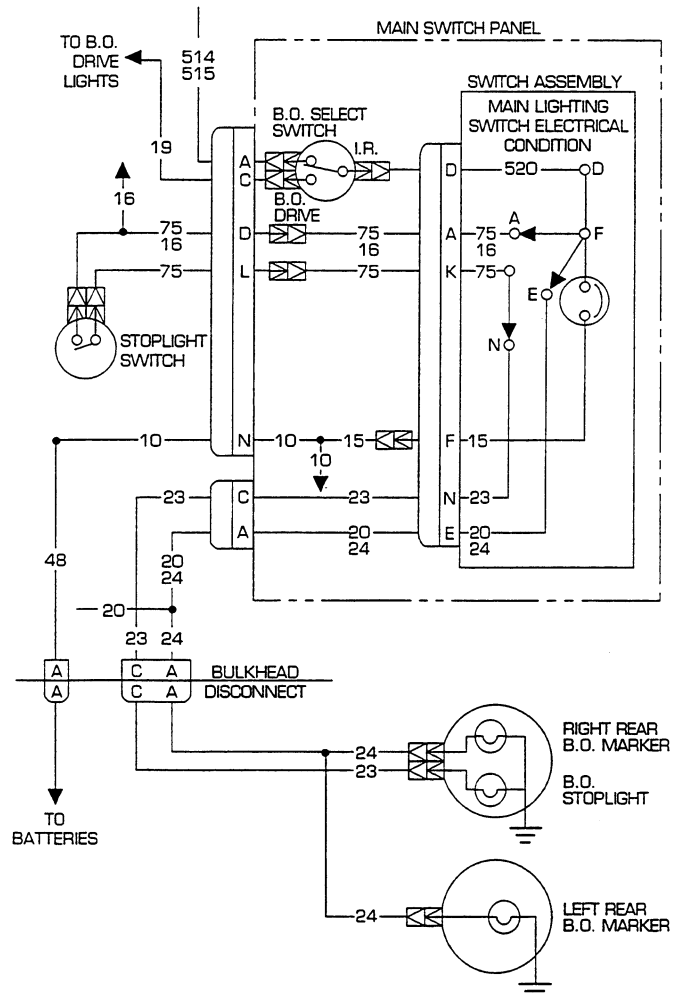
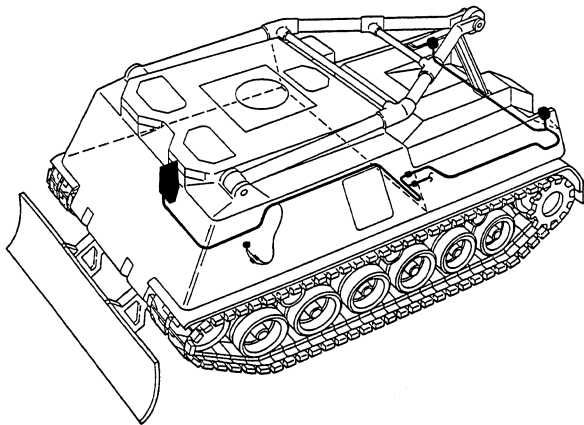

Troubleshooting Procedure

B.O. Service Condition (B.O. Stoplight)

Symptom

B.O. stoplight malfunctioning.

Malfunction

B.O. stoplight fails to operate in any B.O. mode. Do steps 1 thru 11.

CORRECTIVE ACTION

WARNING

Remove all jewelry such as rings, dog tags, bracelets, etc. If jewelry contacts a metal surface a direct short may result in instant heating of tools, damage to equipment, and injury or death to personnel.

- Loosen six screws (1) and remove stoplight cover (2). Remove B.O. stoplight lamp (3). Place red lead of multimeter in socket and black lead to ground. Turn MASTER switch ON, press B.O. MARKER key and ENTER key of main light switch. Depress stoplight switch (vehicle brake) and check for voltage. Turn MASTER, main lighting and stoplight switches OFF. If voltage is present, replace lamp (see WP 0179 00). If voltage is not present, go to step 2.

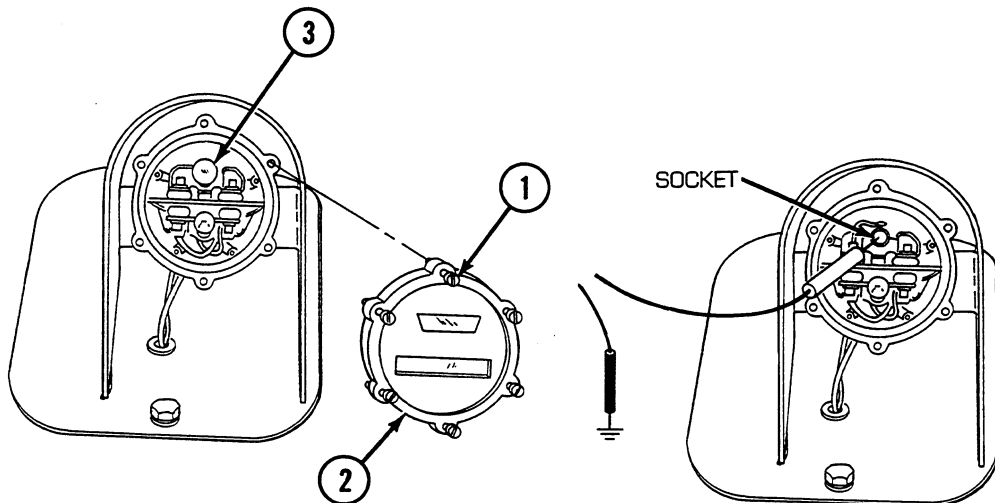

- Install B.O. stoplight lamp (3), stoplight cover (2), and tighten six screws (1). Remove two screws (4) and two lockwashers (5) and remove hydraulic access cover (6). Disconnect wire 23 of bulkhead to master relay and left and right taillight wiring harness from right taillight assembly. Place red lead of multimeter in wire 23 and black lead to ground. Turn MASTER switch ON, press B.O. MARKER key and ENTER key of main light switch, apply brakes, and check for voltage. Turn MASTER and main

CORRECTIVE ACTION –Continued

lighting switches OFF. If voltage is present, replace taillight assembly (see WP 0179 00). If voltage is not present, go to step 3.

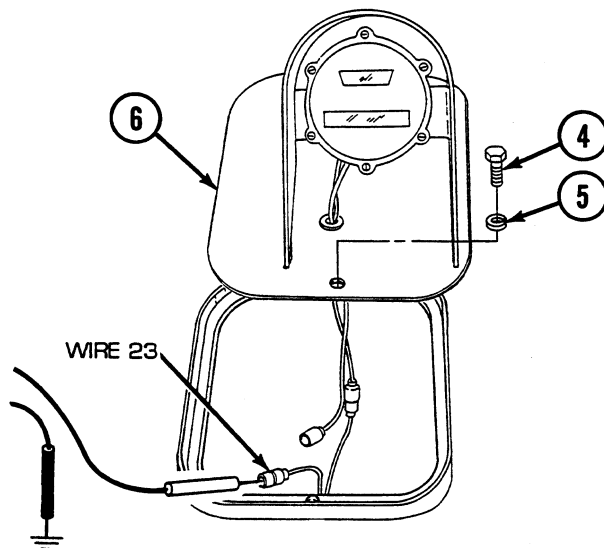

3. Install hydraulic access cover (6), two lockwashers (5), and two screws (4). Open air inlet doors (TM 9-2350-256-10). Disconnect bulkhead to master relay and left and right taillight wiring harness from bulkhead. Place red lead of multimeter in socket C of wire 23 and black lead to ground. Turn MASTER switch ON, press B.O. MARKER key and ENTER key of main light switch, apply brakes, and check for voltage. Turn MASTER and main lighting switches OFF. If voltage is present, repair/replace wire 23 of bulkhead to master relay and left and right taillight wiring harness (see WP 0220 00). If voltage is not present, go to step 4.

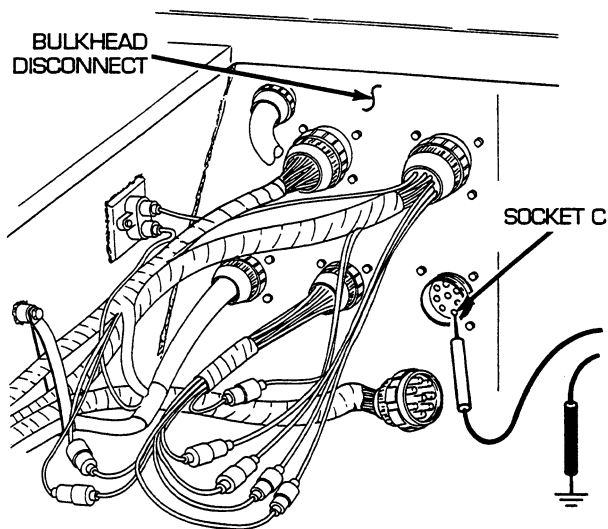

CORRECTIVE ACTION –Continued

4. Remove three screws (7), three lockwashers (8), ground wire (9), flat washer (10), and release main switch panel (11) from mounting brackets. Disconnect switch panel to gage panel and miscellaneous switches wiring harness from main switch panel. Place red lead of multimeter on pin N of wire 10 and black lead to ground. Turn MASTER switch on and check for voltage. Turn MASTER switch OFF. If voltage is present, go to step 5. If voltage is not present, go to step 11.

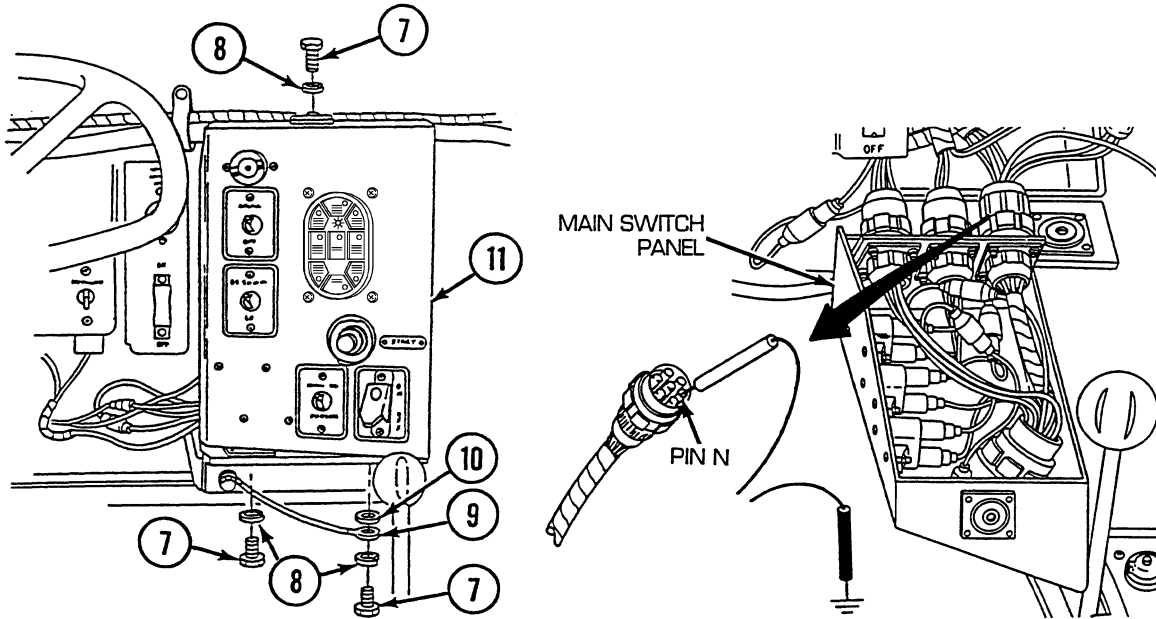

5. Place red lead of multimeter on pin D of wire 75/16 and black lead on pin L of wire 75. Check for continuity. If continuity is present, go to step 6. If continuity is not present, go to step 9.

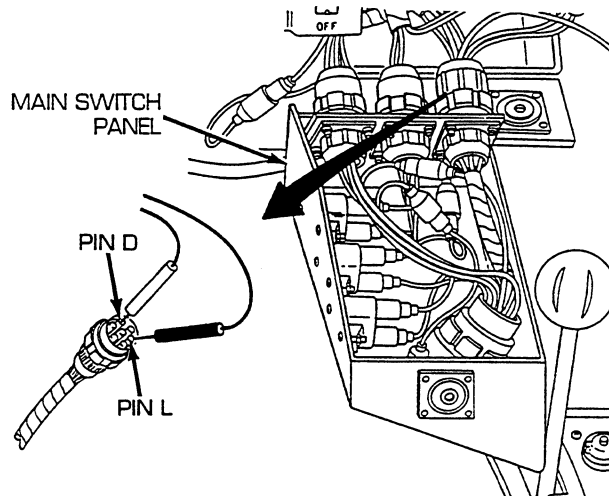

CORRECTIVE ACTION –Continued

6. Reconnect switch panel to gage panel and miscellaneous switches wiring harness to main switch panel. Disconnect wire 75 of main lighting and B.O. selector switch wiring harness at connector. Place red lead of multimeter in female connector of wire 75 and black lead to ground. Turn MASTER switch ON, press B.O. MARKER key and ENTER key on main light switch, and check for voltage. Turn MASTER and main lighting switches OFF. If voltage is present, repair/replace wire 75 of main lighting and B.O. selector switch wiring harness (see WP 0218 00). If voltage is not present, go to step 7.

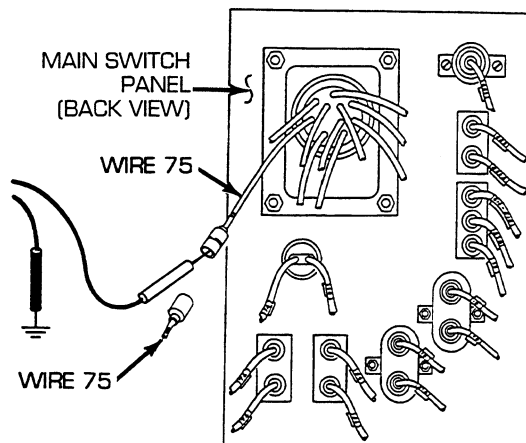

7. Reconnect wire 75 of main lighting and B.O. selector switch wiring harness at connector. Disconnect main lighting and master relay wiring harness from main lighting switch. Place red lead of multimeter on pin N of and black lead on pin K of main switch. Check for continuity. If continuity is present, go to step 8. If continuity is not present, replace main lighting switch (see WP 0159 00).

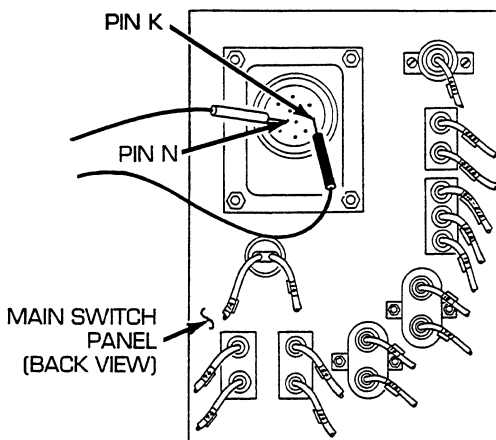

CORRECTIVE ACTION –Continued

8. Place red lead of multimeter on pin A of main switch and black lead on pin F of main switch. Check for continuity. If continuity is present, repair/replace wire 75 of main lighting and master relay wiring harness (see WP 0219 00). If continuity is not present, replace main lighting switch (see WP 0159 00).

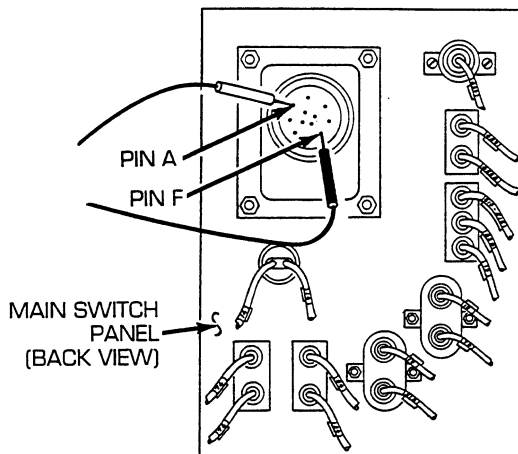

9. Reconnect switch panel to gage panel and miscellaneous switches wiring harness to main switch panel. Install main switch panel (11), flat washer (10), ground wire (9), three lockwashers (8), and three screws (7). Disconnect wire 75/16 at stoplight switch. Place red lead of multimeter in wire 75/16 and black lead to ground. Turn MASTER switch ON, press B.O. MARKER key and ENTER key on main light switch, and check for voltage. Turn MASTER and main lighting switches OFF. If voltage is present, go to step 10. If voltage is not present, repair/replace wire 75/16 of switch panel to gage panel and miscellaneous switches wiring harness (see WP 0204 00 for dual voltage; 0205 00 for single voltage).

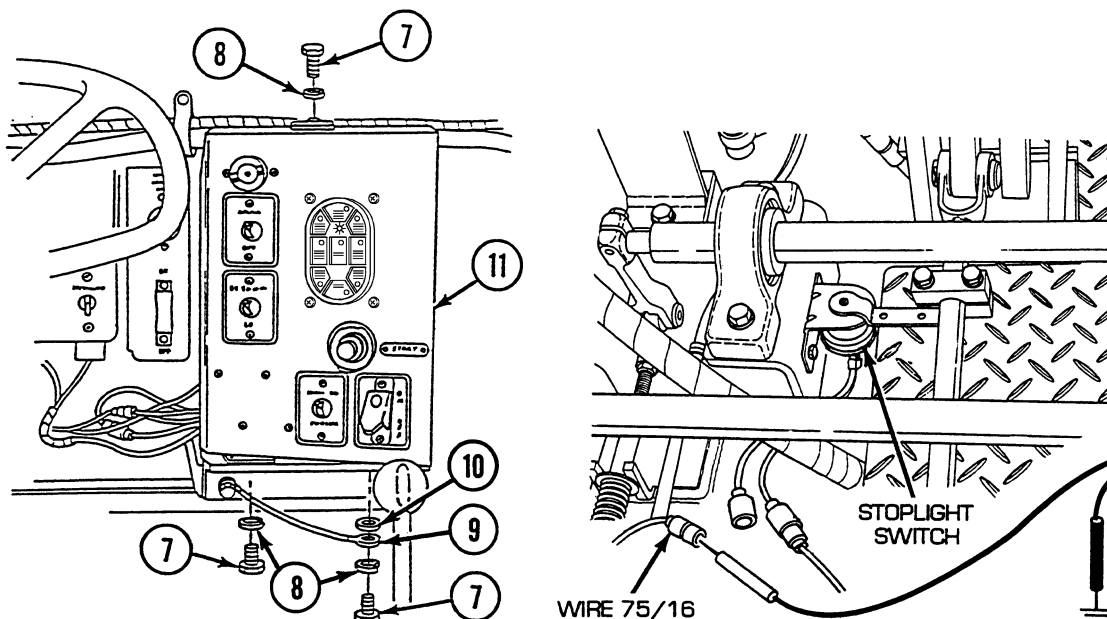

CORRECTIVE ACTION –Continued

10. Reconnect wire 75/16 to stoplight switch. Disconnect wire 75 from stoplight switch. Place red lead of multimeter on wire 75 of stoplight switch and black lead to ground. Turn MASTER switch ON, press B.O. MARKER key and ENTER key on main light switch, press stoplight switch (vehicle brake), and check for voltage. If voltage is present, repair/replace wire 75 of switch panel to gage panel and miscellaneous switches wiring harness (see WP 0204 00 for dual voltage; 0205 00 for single voltage). If voltage is not present, replace stoplight switch (see WP 0172 00).

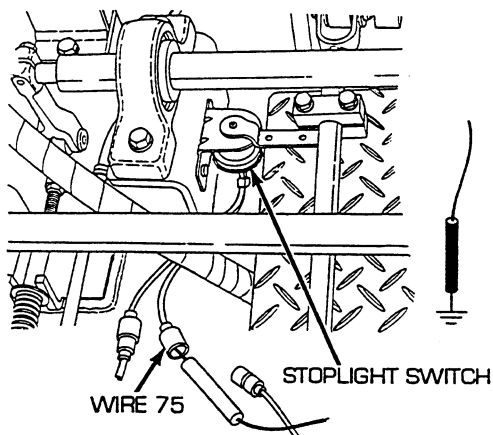

11. Reconnect switch panel to gage panel and miscellaneous switches wiring harness to main switch panel. Install main switch panel (11), flat washer (10), ground lead (9), three lockwashers (8), and three screws (7). Open air inlet doors. Disconnect wire 48 pin A from bulkhead to master relay wiring harness. Place red multimeter lead in socket and black lead to ground. Turn MASTER switch on and check for voltage. If voltage is present, repair/replace switch panel, radio, and bilge pump to bulkhead wiring harness (see WP 0202 00). If voltage is not present, troubleshoot master relay circuit (see WP 0042 00).

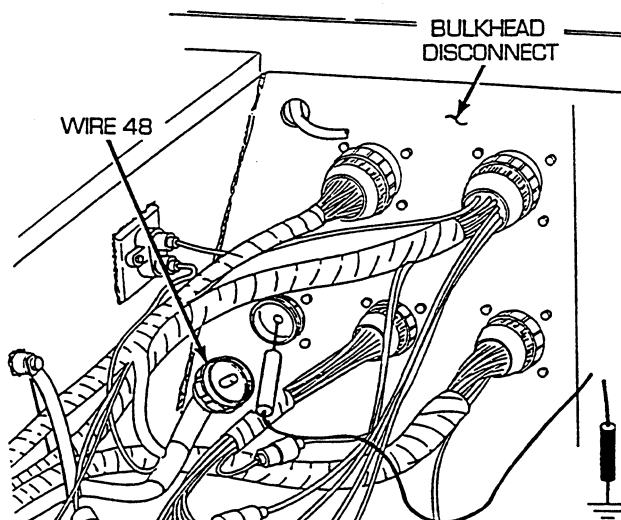
**END OF WORK PACKAGE**

UNIT MAINTENANCE
RECOVERY VEHICLE, FULL TRACKED: MEDIUM, M88A1
NSN 2350-00-122-6826, EIC AQA
B.O. MARKER CONDITION TROUBLESHOOTING PROCEDURE

INITIAL SETUP:**Tools and Special Tools**

Tool kit, general mechanic's (item 59, WP 0490 00)

References

WP 0042 00
WP 0159 00
WP 0175 00

References (cont.)

WP 0179 00
WP 0202 00
WP 0214 00
WP 0218 00
WP 0219 00
TM 9-2350-256-10

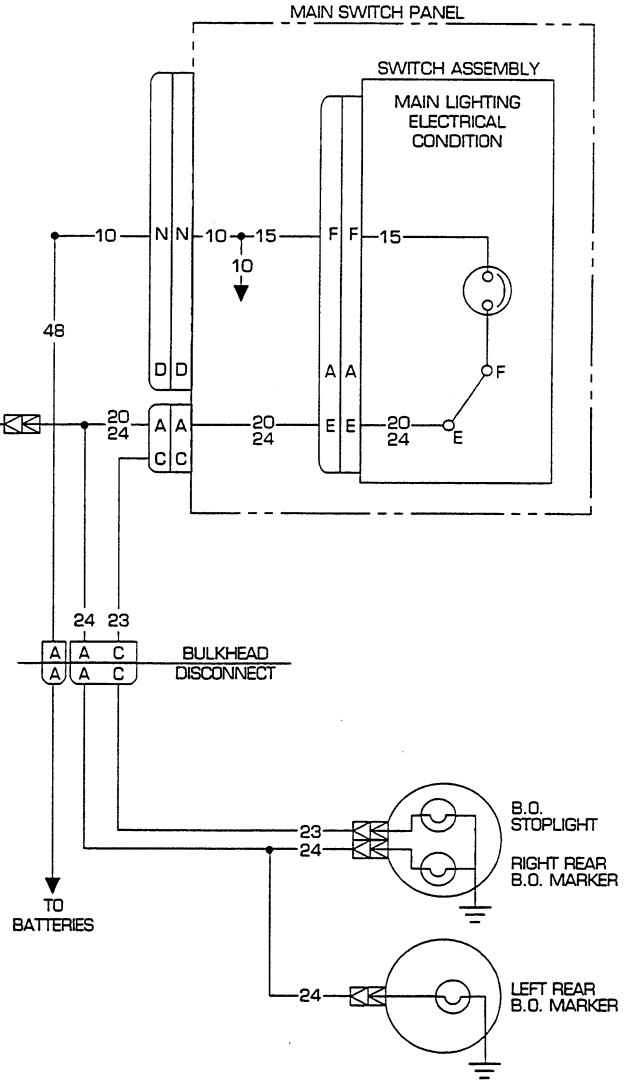
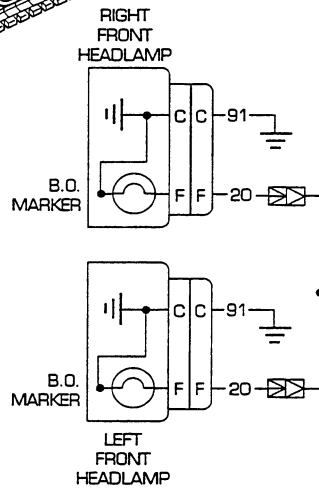
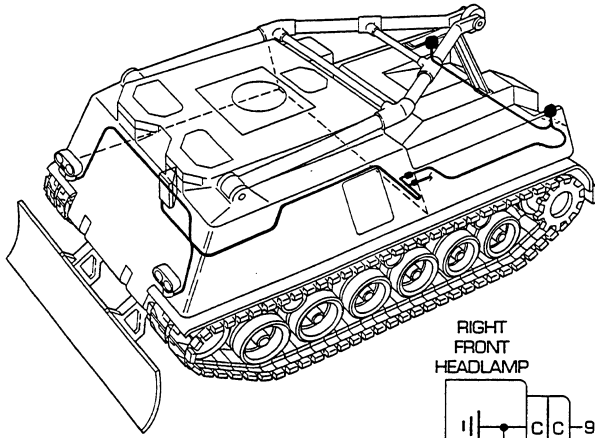

Troubleshooting Procedure

B.O. Marker Condition

Symptom

B.O. marker malfunctioning.

Malfunction

Front B.O. marker fails to operate. Do steps 1 thru 11.

Rear B.O. marker fails to operate. Do steps 4 thru 11.

CORRECTIVE ACTION

WARNING

Remove all jewelry such as rings, dog tags, bracelets, etc. If jewelry contacts a metal surface a direct short may result in instant heating of tools, damage to equipment, and injury or death to personnel.

1. Loosen four screws (1) and remove cover (2) and B.O. marker light (3). Place red lead of multimeter in socket and black lead to ground. Turn MASTER switch ON, press B.O. MARKER key and ENTER key on main light switch, and check for voltage. If voltage is present, replace marker light (see WP 0175 00). If voltage is not present, go to step 2.

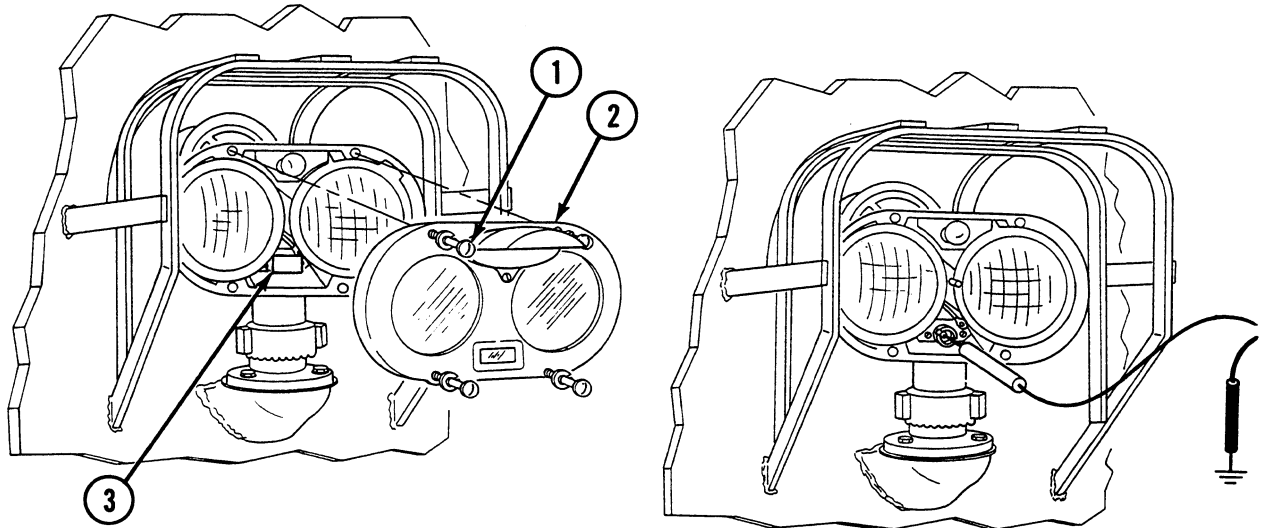

CORRECTIVE ACTION –Continued

2. Install marker light (3) and cover (2) and tighten four screws (1). Loosen adjustment nut (4) and remove headlight assembly (5).

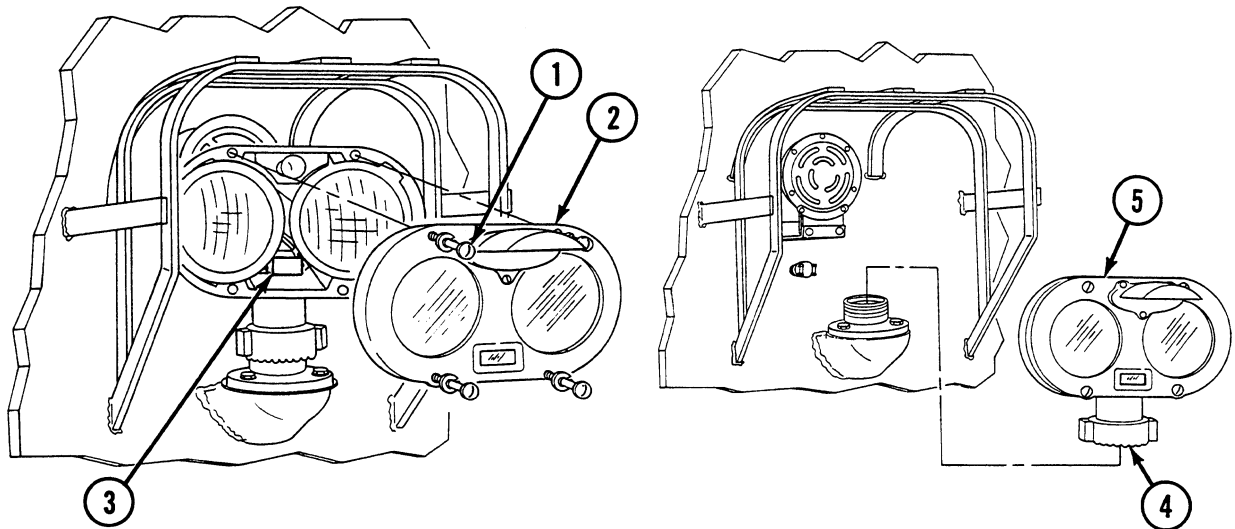

Place red lead of multimeter in socket F of wire 20 and black lead to ground. Turn MASTER switch ON, press B.O. MARKER key and ENTER key on main light switch, and check for voltage. Turn MASTER and main light switches OFF. If voltage is present, replace lamp (see WP 0175 00). If voltage is not present, go to step 3.

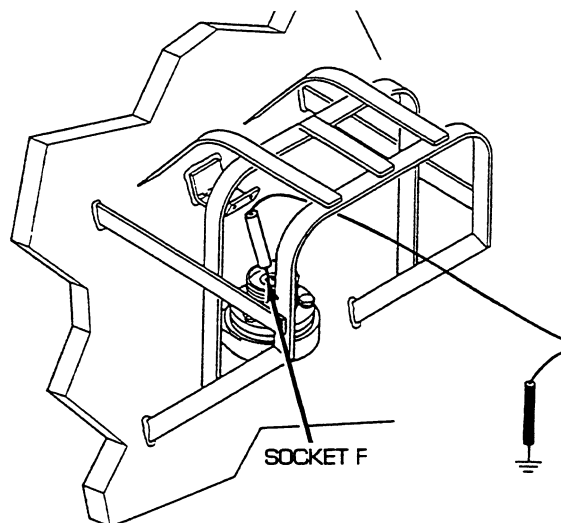

CORRECTIVE ACTION –Continued

3. Reconnect headlight base assembly to headlight assembly. Disconnect wire 20 of headlight base assembly from switch panel to head lamps and bulkhead wiring harness. Place red lead of multimeter on male connector of wire 20 and black lead to ground. Turn MASTER switch ON, press B.O. MARKER key and ENTER key on main light switch, and check for voltage. Turn MASTER and main lighting switches OFF. If voltage is present, repair/replace wire 20 of headlight and dimmer switch wiring harness (see WP 0214 00). If voltage is not present, go to step 7.

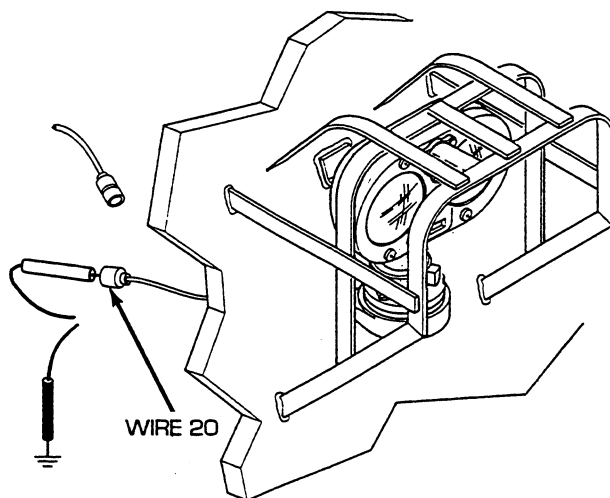

4. Loosen six screws (6) and remove cover (7) and lamp. Place red lead of multimeter in socket and black lead to ground. Turn MASTER switch ON, press B.O. MARKER key and ENTER key on main light switch, and check for voltage. Turn MASTER and main lighting switches OFF. If voltage is present, replace lamp (see WP 0179 00). If voltage is not present, go to step 5.

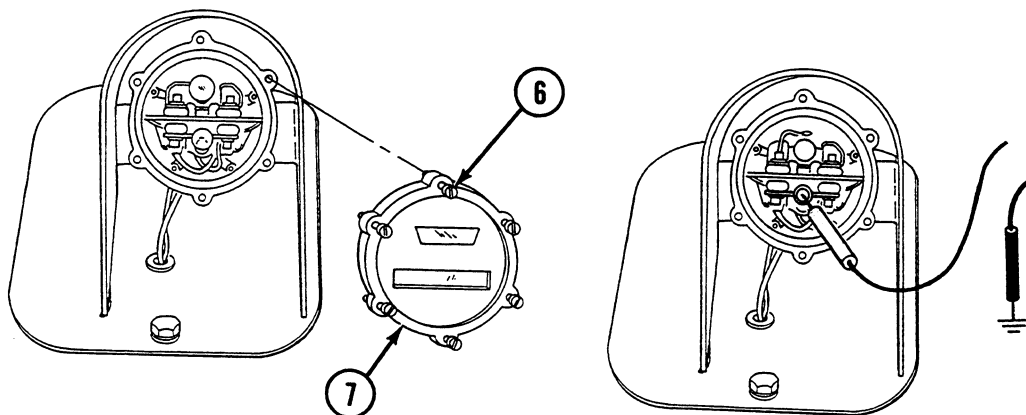

CORRECTIVE ACTION –Continued

5. Remove two screws (8), two lockwashers (9), and hydraulic access plate (10). Disconnect wire 24 of bulkhead to master relay and left and right taillight wiring harness from taillight. Place red lead of multimeter in wire 24 and black lead to ground. Turn MASTER switch ON, press B.O. MARKER key and ENTER key on main light switch, and check for voltage. Turn MASTER and main lighting switches OFF. If voltage is present, replace lamp (see WP 0175 00). If voltage is not present, go to step 6.

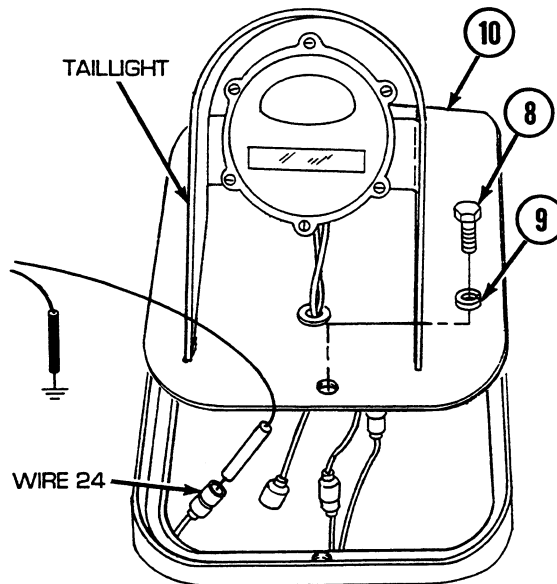

6. Reconnect wire 24 of bulkhead to master relay and left and right taillight wiring harness to taillight. Open air inlet doors (TM 9-2350-256-10). Disconnect bulkhead to master relay and left and right taillight wiring harness from bulkhead. Place red lead of multimeter in socket A of wire 20/24 and black lead to ground. Turn MASTER switch ON, press B.O. MARKER key and ENTER key on main light switch, and check for voltage. Turn MASTER and main lighting switches OFF. If voltage is present, repair/replace wire 24 of bulkhead to master relay and left and right taillight wiring harness (see WP 0214 00). If voltage is not present, go to step 7.

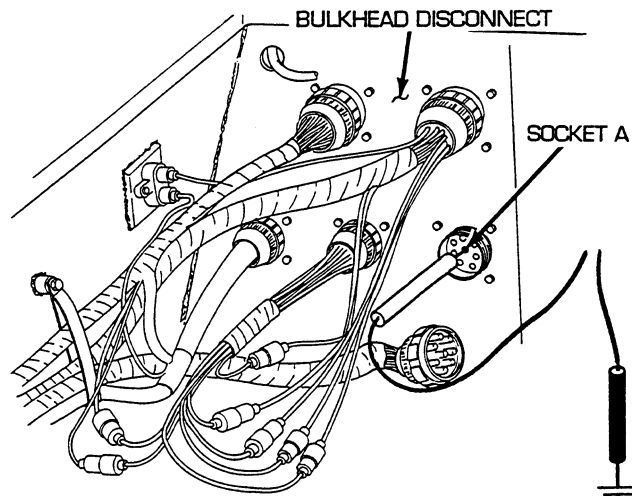

CORRECTIVE ACTION –Continued

7. Reconnect switch panel to head lamps and bulkhead wiring harness to main switch panel. Remove three screws (11), three lockwashers (12), ground lead (13), and flat washer (14) and release main switch panel (15) from mounting brackets. Disconnect switch panel to gage panel and miscellaneous switches wiring harness from main switch panel. Place red lead of multimeter on pin N of wire 10 and black lead to ground. Turn MASTER switch on and check for voltage. Turn MASTER switch OFF. If voltage is present, go to step 8. If voltage is not present, go to step 11.

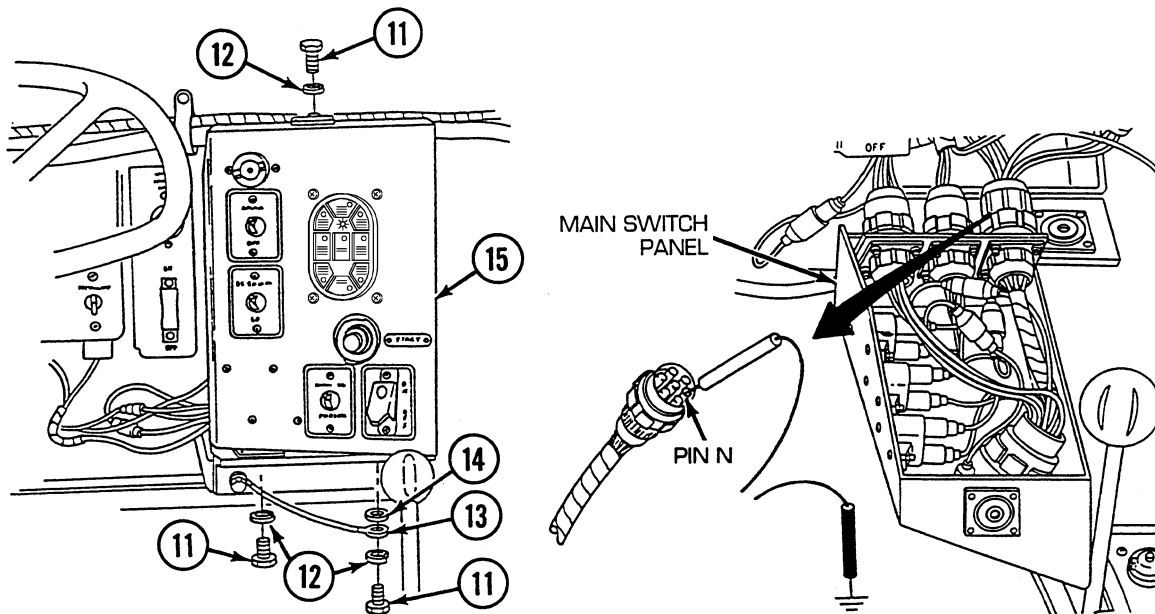

8. Reconnect switch panel to gage panel and miscellaneous switches wiring harness to main switch panel. Ground main switch panel. Disconnect wire 10/15 at connector. Place red lead of multimeter in wire 10/15 and black lead to ground. Turn MASTER switch on and check for voltage. Turn MASTER switch OFF. If voltage is present, go to step 9. If voltage is not present, repair/replace wire 10/15 of main lighting and B.O. selector switch wiring harness (see WP 0218 00).

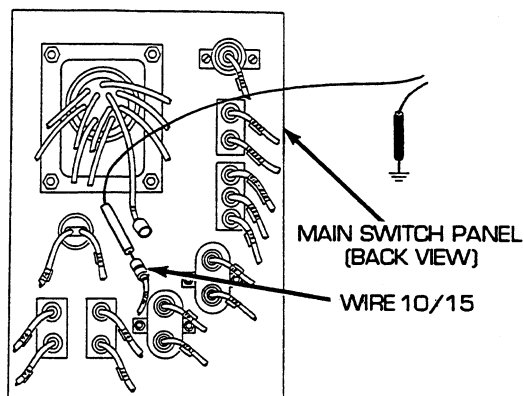

CORRECTIVE ACTION –Continued

9. Reconnect wire 10/15 at connector. Disconnect main lighting and master relay wiring harness from main lighting switch. Place red lead of multimeter in socket F of wire 15 and black lead to ground. Turn MASTER switch on and check for voltage. Turn MASTER switch OFF. If voltage is present, go to step 10. If voltage is not present, repair/replace wire 15 of main lighting and master relay wiring harness (see WP 0219 00).

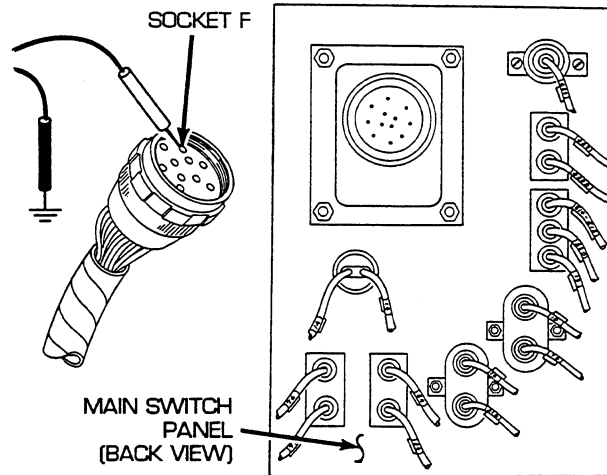

10. Place a jumper wire from socket F to pin F. Place red lead of multimeter on pin E of wire 20/24 and black lead to ground. Turn MASTER switch ON, press B.O. MARKER key and ENTER key, and check for voltage. Turn MASTER and main lighting switches to OFF. If voltage is present, repair/replace wire 20/24 of main lighting and master relay wiring harness assembly (see WP 0219 00). If voltage is not present, replace main lighting switch (see WP 0159 00).

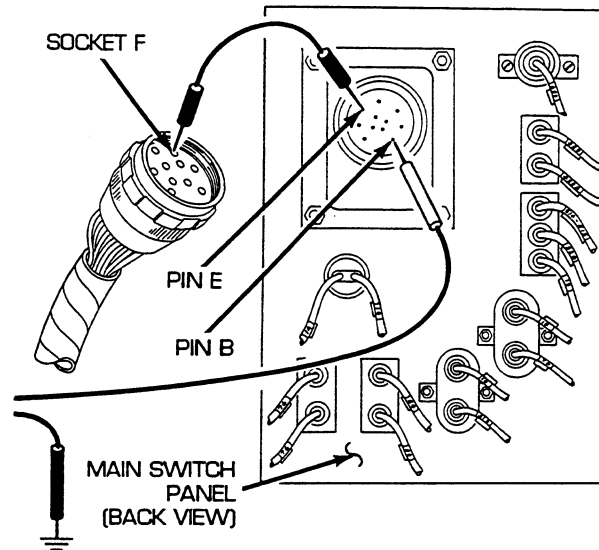

CORRECTIVE ACTION –Continued

11. Reconnect switch panel to gage panel and miscellaneous switches wiring harness to main switch panel. Install main switch panel (15), flat washer (14), ground lead (13), three lockwashers (12), and three screws (11). Open air inlet doors (TM 9-2350-256-10). Disconnect wire 48 pin A from bulkhead to master relay wiring harness. Place red multimeter lead in socket and black lead to ground. Turn MASTER switch on and check for voltage. If voltage is present, repair/replace switch panel, radio, and bilge pump to bulkhead wiring harness (see WP 0202 00). If voltage is not present, troubleshoot master relay circuit (see WP 0042 00).

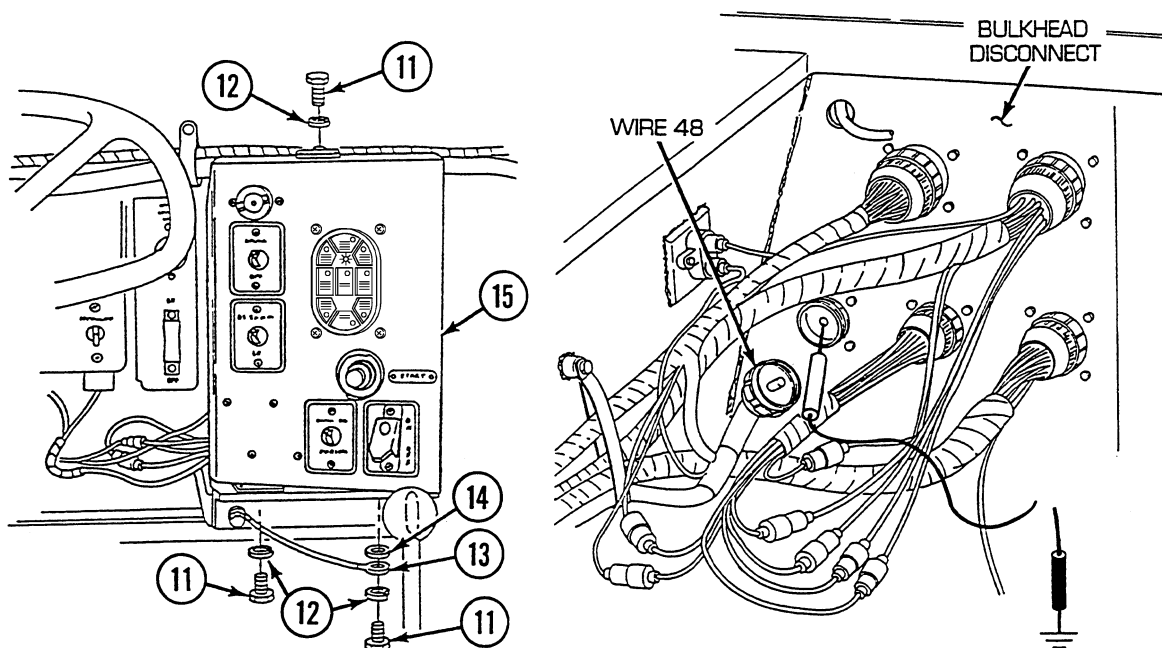
**END OF WORK PACKAGE**

UNIT MAINTENANCE
RECOVERY VEHICLE, FULL TRACKED: MEDIUM, M88A1
NSN 2350-00-122-6826, EIC AQA

B.O. DRIVE CONDITION TROUBLESHOOTING PROCEDURE

INITIAL SETUP:

Tools and Special Tools

Tool kit, general mechanic's (item 59, WP 0490 00)

References (cont.)

References

- WP 0042 00
- WP 0159 00
- WP 0175 00
- WP 0202 00

- WP 0213 00
- WP 0214 00
- WP 0217 00
- WP 0218 00
- WP 0219 00
- TM 9-2350-256-10

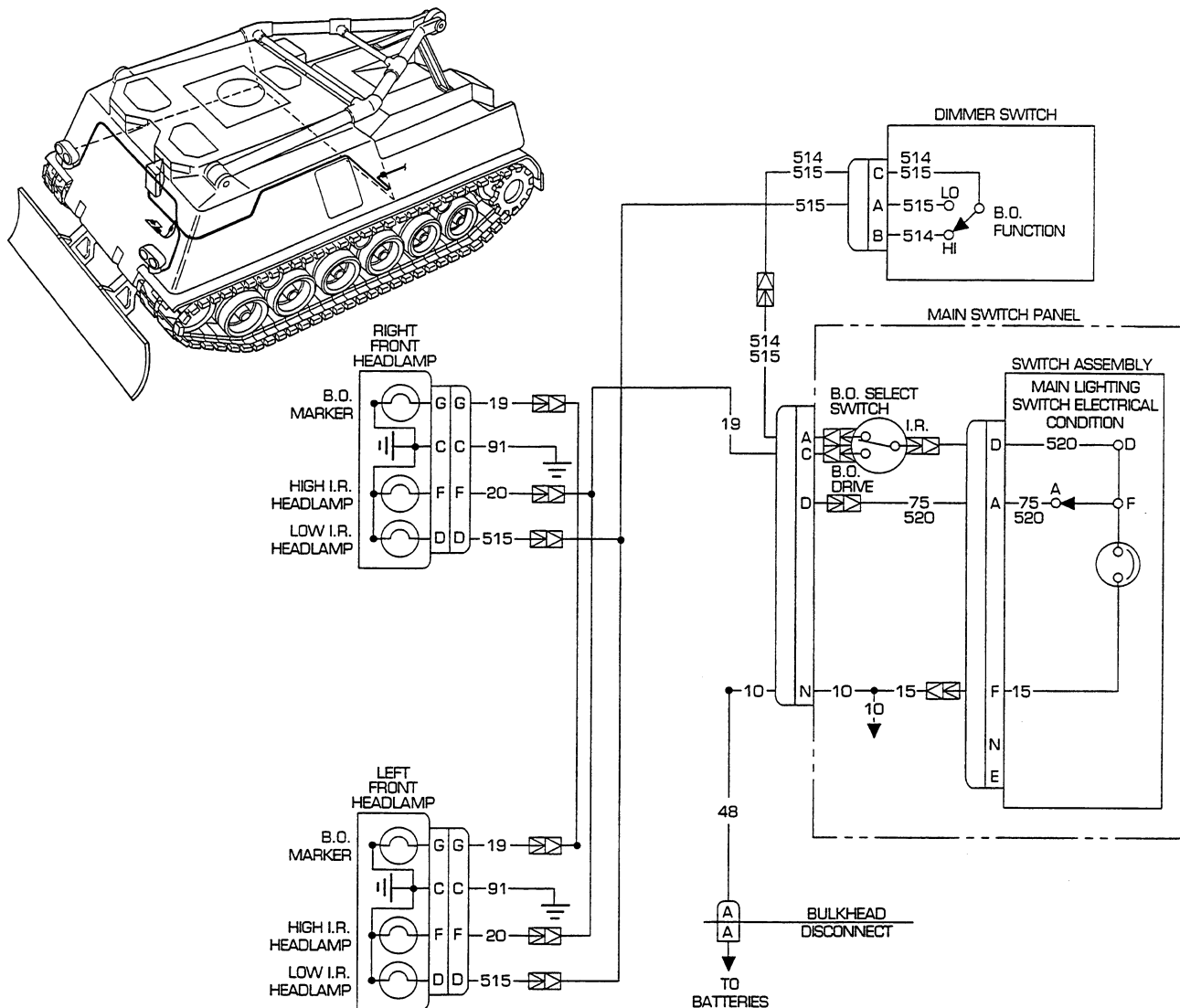

Troubleshooting Procedure

B.O. Drive Condition

Symptom

B.O. drive lights malfunctioning.

Malfunction

B.O. drive lights fail to operate. Do steps 1 thru 11.

CORRECTIVE ACTION

WARNING

Remove all jewelry such as rings, dog tags, bracelets, etc. If jewelry contacts a metal surface a direct short may result in instant heating of tools, damage to equipment, and injury or death to personnel.

1. Loosen four screws (1) and remove cover (2) of left hand headlight assembly. Remove lamp and place red lead of multimeter in socket and black lead to ground. Turn MASTER switch ON, press B.O. DRIVE key and ENTER key on main light switch, and check for voltage. Turn MASTER and B.O. SELECTOR switches OFF. If voltage is present, replace bulb (see WP 0175 00). If voltage is not present, go to step 2.

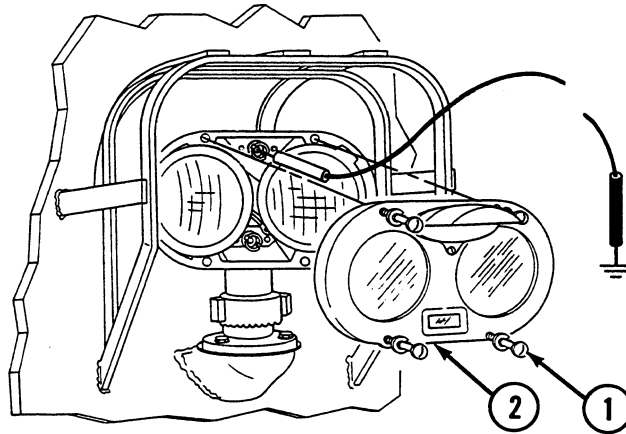

CORRECTIVE ACTION –Continued

2. Disconnect headlight base assembly from left hand headlight assembly. Place red lead of multimeter in socket G of wire 19 and black lead to ground. Turn MASTER switch ON, press B.O. DRIVE key and ENTER key on main light switch, and check for voltage. Turn MASTER, main lighting, and B.O. SELECTOR switches OFF. If voltage is present, replace headlight assembly (see WP 0175 00). If voltage is not present, go to step 3.

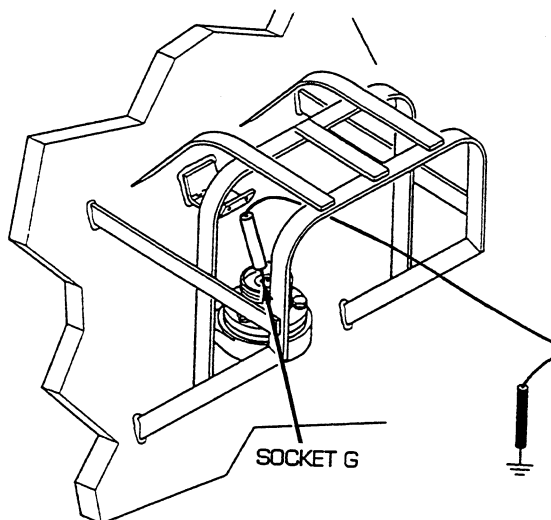

3. Reconnect headlight base assembly to left hand headlight assembly. Disconnect wire 19 of headlight and dimmer switch wiring harness from switch panel to gage panel and miscellaneous switches wiring harness. Place red lead of multimeter on male connector of wire 19 and black lead to ground. Turn MASTER switch ON, press B.O. DRIVE key and press ENTER key on main light switch. Place B.O. SELECTOR switch to B.O. position and check for voltage. Turn MASTER, main lighting, and B.O. SELECTOR switches OFF. If voltage is present, go to step 4. If voltage is not present, go to step 5.

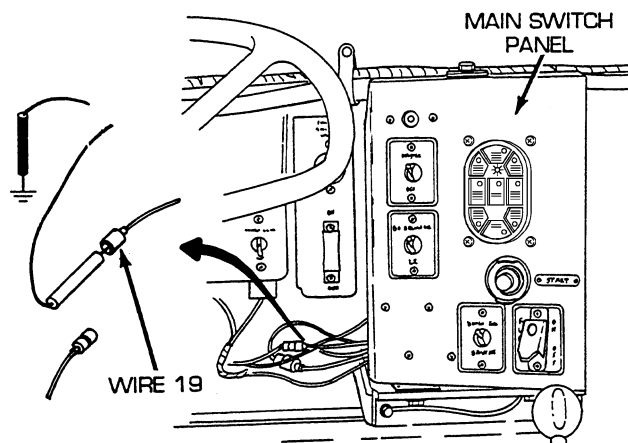

CORRECTIVE ACTION –Continued

4. Reconnect wire 19 of headlight and dimmer switch wiring harness to switch panel to gage panel and miscellaneous switches wiring harness. Disconnect wire 19 of headlight base assembly from headlight and dimmer switch wiring harness. Place red lead of multimeter in wire 19 and black to ground. Turn MASTER switch ON, press B.O. DRIVE key and press ENTER key on main light switch. Place B.O. SELECTOR switch to B.O. position and check for voltage. Turn MASTER, main lighting, and B.O. SELECTOR switches OFF. If voltage is not present, repair/replace wire 19 of headlight and dimmer switch wiring harness (see WP 0214 00). If voltage is present, repair/replace wire 19 of headlight base wiring harness (see WP 0213 00).

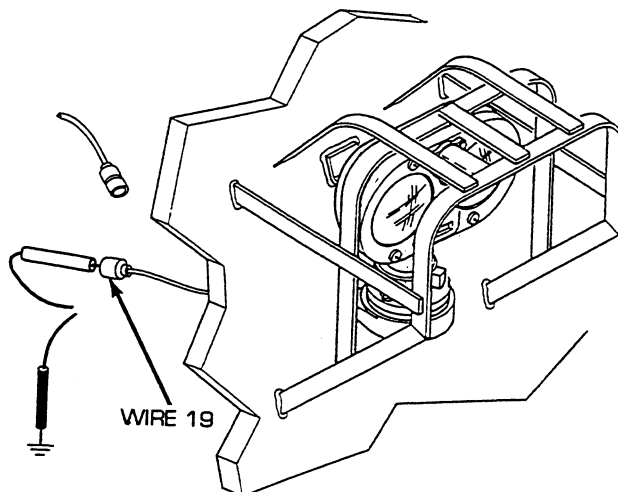

5. Remove three screws (3), three lockwashers (4), ground lead (5), flat washer (6), and release main switch panel (7) from mounting bracket. Reconnect wire 19 of headlight and dimmer switch panel to gage panel and miscellaneous switches wiring harness. Disconnect wire 19 from B.O. SELECTOR switch. Place red lead of multimeter on terminal of switch and black lead to ground. Turn MASTER switch ON, press B.O. DRIVE key and ENTER key on main light switch. Place B.O. SELECTOR switch to B.O. position and check for voltage. Turn MASTER, main lighting, and B.O. SELECTOR switches OFF. If voltage is present, repair/replace wire 19 of main lighting and B.O. selector switch wiring harness (see WP 0218 00). If voltage is not present, go to step 6.

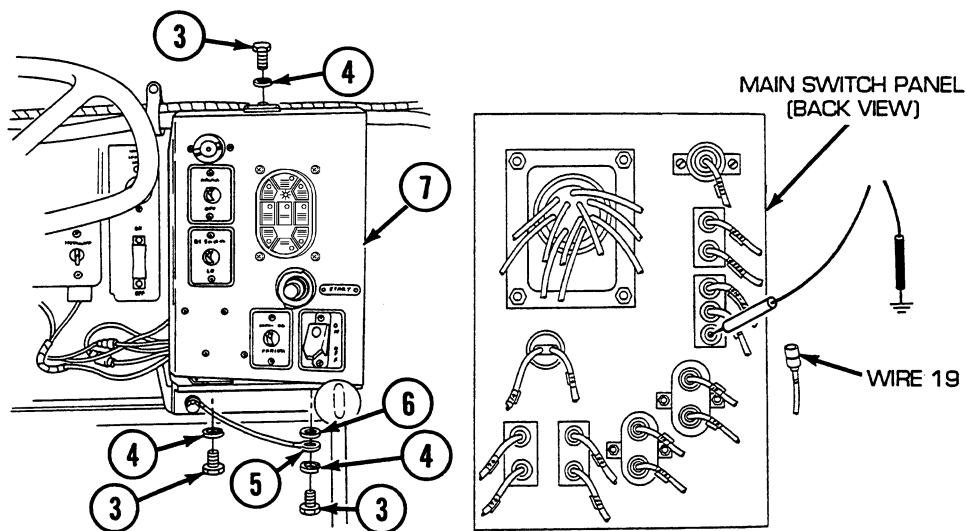

CORRECTIVE ACTION –Continued

6. Reconnect wire 19 to B.O. SELECTOR switch. Disconnect wire 520 from B.O. SELECTOR switch. Place red lead of multimeter in wire 520 and black lead to ground. Turn MASTER switch ON, press B.O. DRIVE key and ENTER key on main light switch, and check for voltage. Turn MASTER and main lighting switches OFF. If voltage is present, replace switch (see WP 0159 00). If voltage is not present, go to step 6.

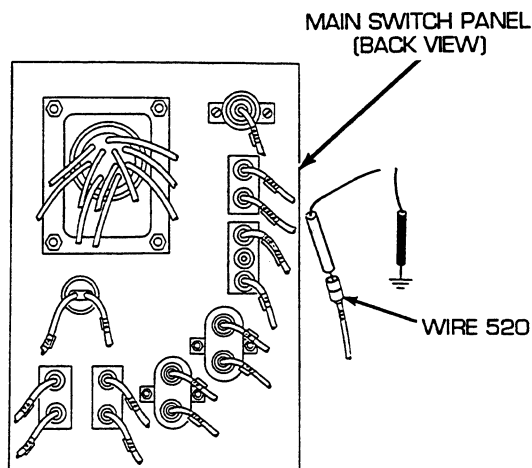

7. Reconnect wire 520 to B.O. SELECTOR switch. Disconnect main lighting and master relay wiring harness from main lighting switch. Place a jumper wire from pin F to socket F. Place red lead of multimeter on pin D of wire 520 and black lead to ground. Turn MASTER switch ON, press B.O. DRIVE key and ENTER key on main light switch, and check for voltage. Turn MASTER and main lighting switches OFF. If voltage is present, go to step 8. If voltage is not present, go to step 9.

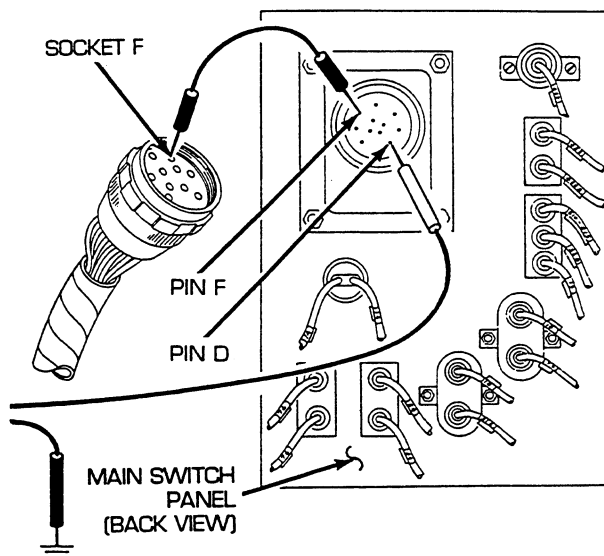

CORRECTIVE ACTION –Continued

8. Reconnect main lighting and master relay wiring harness to main lighting switch. Disconnect wire 520 at female connector, near main lighting switch. Place red lead of multimeter in female connector of wire 520 and black lead to ground. Turn MASTER switch ON, press B.O. DRIVE key and ENTER key on main light switch, and check for voltage. Turn MASTER and main lighting switches OFF. If voltage is present, repair/replace wire 520 of B.O. selector lead assembly (see WP 0217 00). If voltage is not present, repair/replace wire 520 of main lighting and master relay wiring harness (see WP 0219 00).

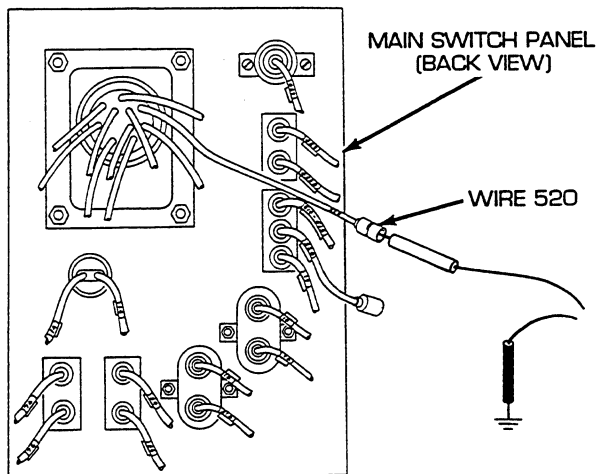

9. Place red lead of multimeter in socket F of wire 15 and black lead to ground. Turn MASTER switch on and check for voltage. Turn MASTER switch OFF. If voltage is present, replace main lighting switch (see WP 0159 00). If voltage is not present, go to step 10.

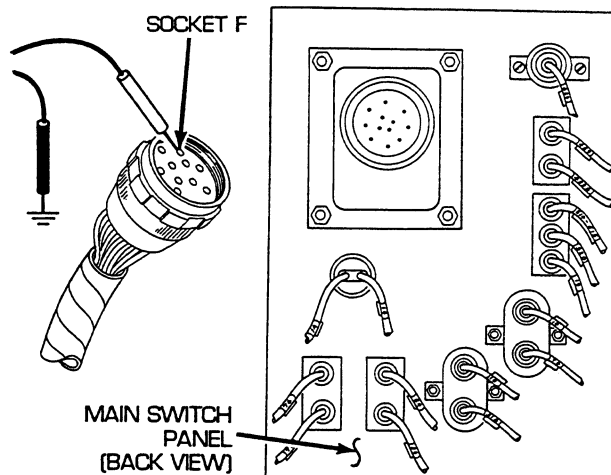

10. Reconnect main lighting and master relay wiring harness to main lighting switch. Disconnect switch panel to gage panel and miscellaneous switches wiring harness from main switch panel. Place red lead of multimeter on pin N of wire 10 and black lead to ground. Turn MASTER switch on and check for

CORRECTIVE ACTION –Continued

voltage. Turn MASTER switch OFF. If voltage is present, repair/replace wire 10 of main lighting and B.O. selector switch wiring harness (see WP 0218 00). If voltage is not present, go to step 11.

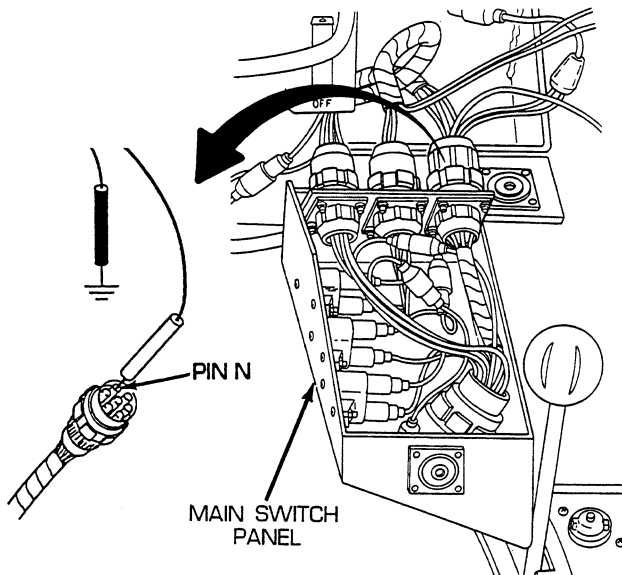

11. Reconnect switch panel to gage panel and miscellaneous switches wiring harness to main switch panel. Open air inlet doors (TM 9-2350-256-10). Disconnect wire 48 pin A from bulkhead to master relay wiring harness. Place red multimeter lead in socket and black lead to ground. Turn MASTER switch on and check for voltage. If voltage is present, repair/replace switch panel, radio, and bilge pump to bulkhead wiring harness (see WP 0202 00). If voltage is not present, troubleshoot master relay circuit (see WP 0042 00).

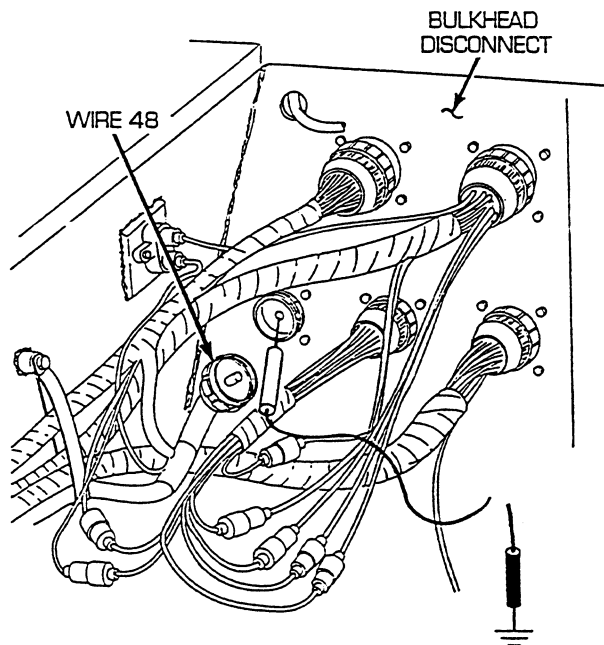

END OF WORK PACKAGE

UNIT MAINTENANCE
RECOVERY VEHICLE, FULL TRACKED: MEDIUM, M88A1
NSN 2350-00-122-6826, EIC AQA

RIGGER'S LIGHTS AND FRONT SIGNAL LIGHT TROUBLESHOOTING PROCEDURE

INITIAL SETUP:**Tools and Special Tools**

Tool kit, general mechanic's (item 59, WP 0490 00)

References

WP 0042 00
WP 0159 00
WP 0160 00
WP 0173 00
WP 0176 00
WP 0177 00
WP 0202 00
WP 0204 00

References (cont.)

WP 0205 00
WP 0215 00
WP 0216 00
WP 0218 00
WP 0219 00
WP 0224 00
WP 0225 00
WP 0228 00
WP 0229 00
TM 9-2350-256-10

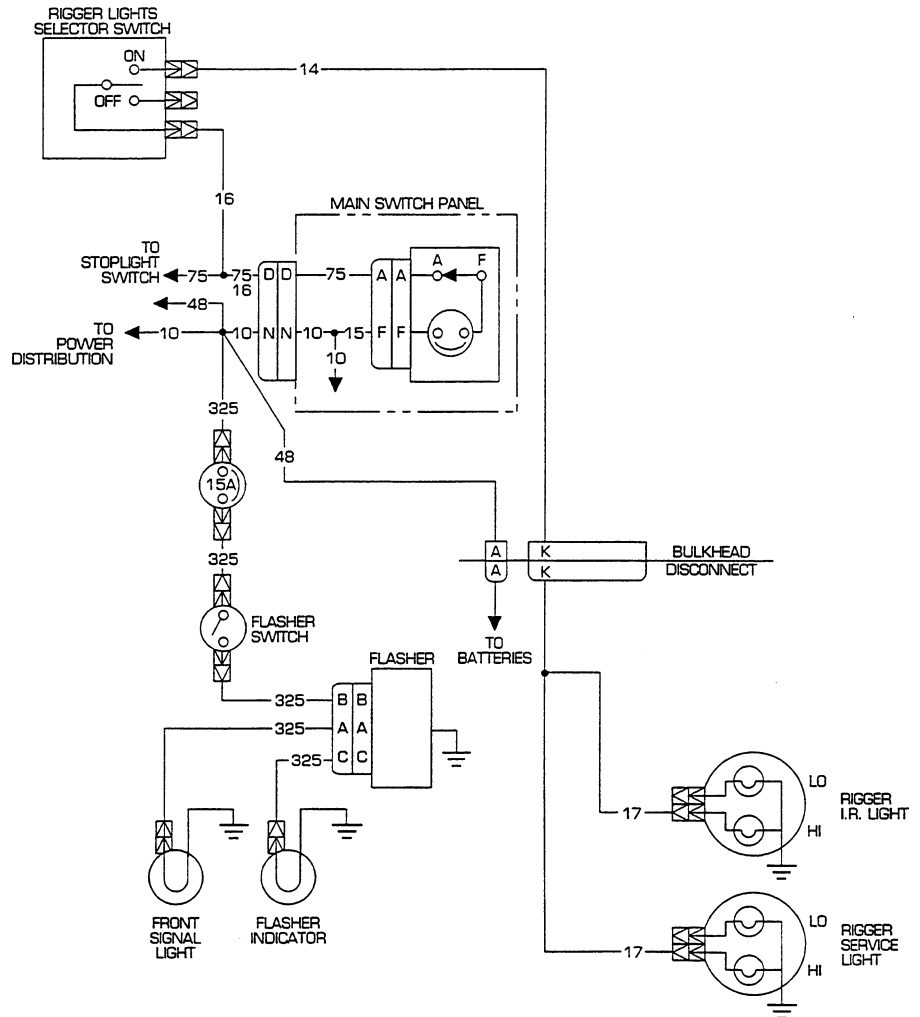
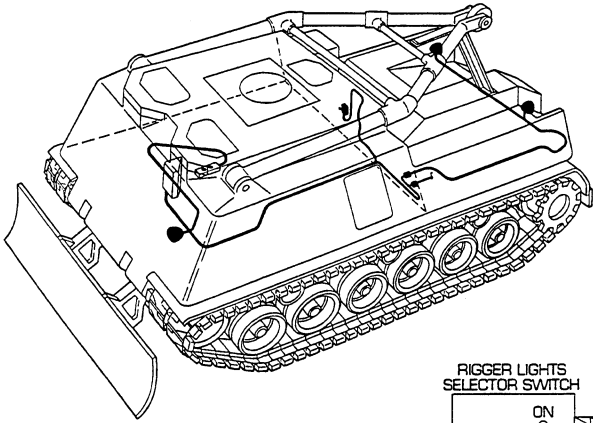

Troubleshooting Procedure

Rigger's Lights and Front Signal Light

Symptom

Rigger's light or front signal light malfunctioning.

Malfunction

One or both rigger's service lamp fails to operate. Do steps 1 thru 10.

Front signal light and/or indicator light fails to operate, but indicator lamp operates. Do steps 11 thru 19.

CORRECTIVE ACTION

WARNING

Remove all jewelry such as rings, dog tags, bracelets, etc. If jewelry contacts a metal surface a direct short may result in instant heating of tools, damage to equipment, and injury or death to personnel.

1. Loosen four screws (1) and remove cover (2). Remove bulb (3). Place red lead of multimeter in socket and black lead to ground. Turn MASTER switch On, press STOP LIGHT key and ENTER key on main light switch and set rigger's B.O SELECTOR to SERVICE position, and check for voltage. Turn MASTER and B.O. SELECTOR switches OFF. If voltage is present, replace lamp (see WP 0176 00). If voltage is not present, go to step 2.

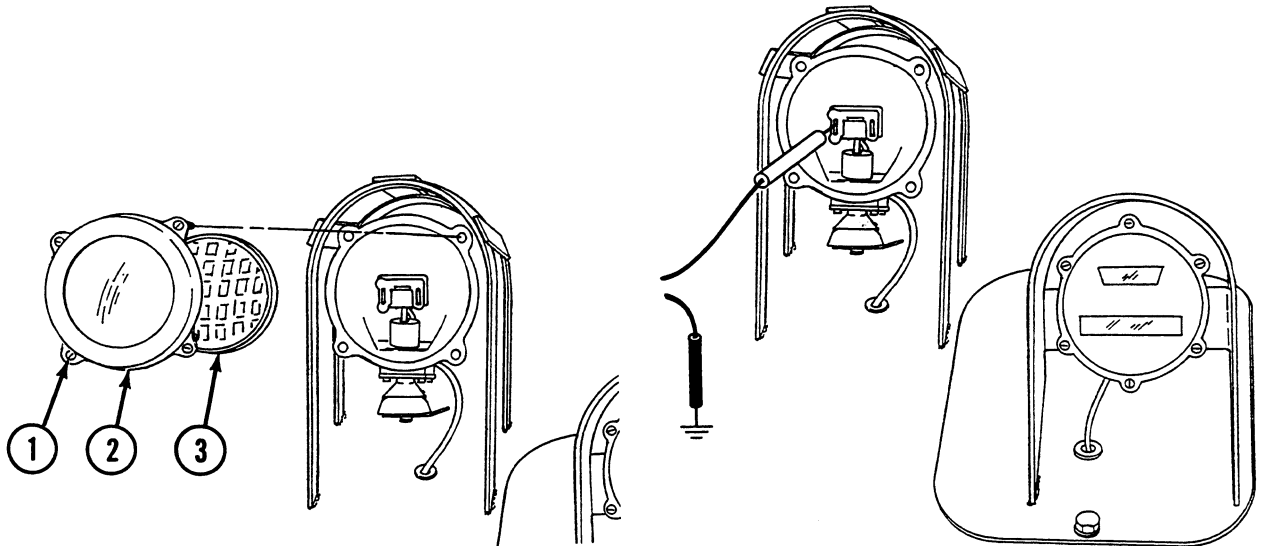

CORRECTIVE ACTION –Continued

2. Install bulb (3), cover (2), and tighten four screws (1). Disconnect wire 17 from failed rigger's service light. Place red lead of multimeter in wire 17 and black lead to ground. Turn MASTER switch ON, press STOP LIGHT and ENTER key on main light switch and set rigger's B.O. SELECTOR to SERVICE position, and check for voltage. Turn MASTER, main lighting, and rigger's B.O. SELECTOR switches OFF. If voltage is present, replace rigger's service light assembly (see WP 0176 00). If voltage is not present, go to step 3.

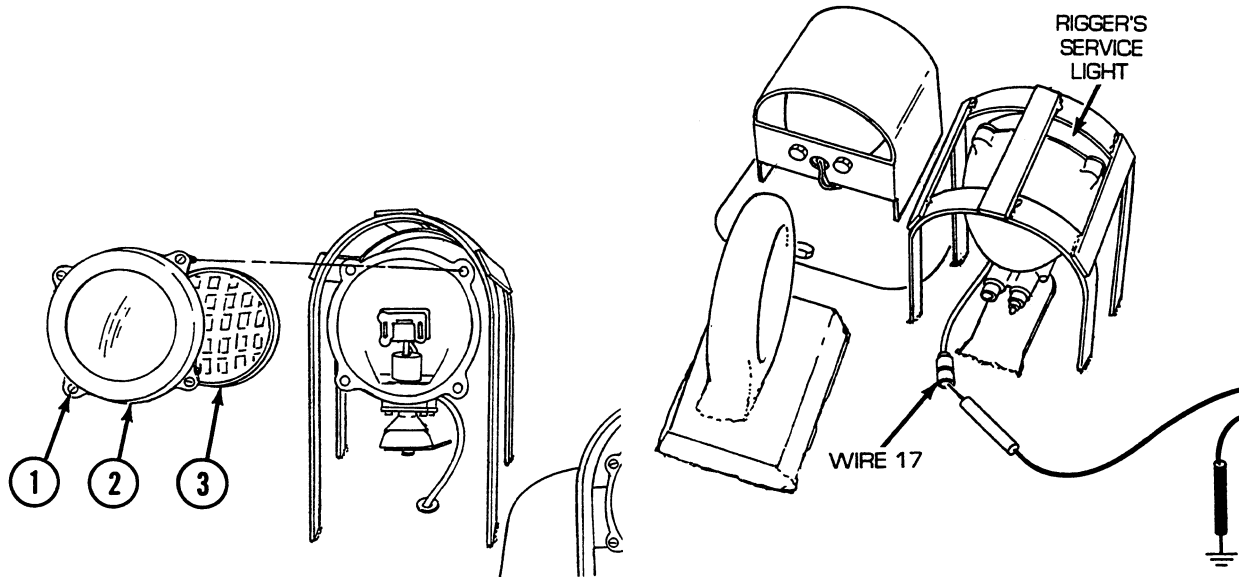

3. Reconnect wire 17 to light. Disconnect wire 17 from rigger's SERVICE switch. Place red lead of multimeter on switch terminal and black lead to ground. Turn MASTER switch ON, press STOP LIGHT key and ENTER key on main light switch, set rigger's B.O. SELECTOR to SERVICE position, and check for voltage. Turn MASTER, main lighting, and rigger's B.O. SELECTOR switches OFF. If voltage is present, go to step 4. If voltage is not present, go to step 5.

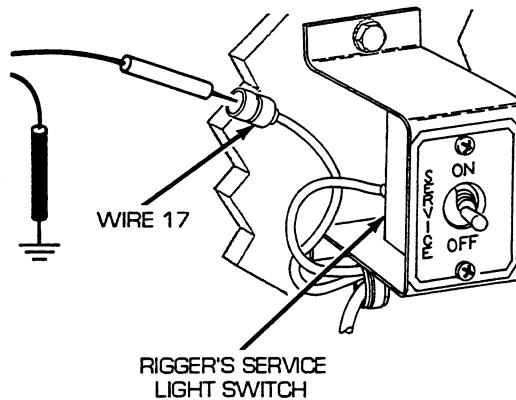

CORRECTIVE ACTION –Continued

4. Reconnect wire 17 to rigger's SERVICE switch. Open air inlet doors (TM 9-2350-256-10). Disconnect bulkhead to APU, master relay, and rigger's lights wiring harness from bulkhead disconnect. Place red lead of multimeter on pin K of wire 17 and black lead to ground. Turn MASTER switch ON, press STOP LIGHT key and ENTER key on main light switch, set rigger's B.O. SELECTOR to SERVICE position, and check for voltage. Turn MASTER, main lighting, and rigger's B.O. SELECTOR switches OFF. If voltage is not present, repair/replace wire 17 of APU control box to foot dimmer switch and bulkhead wiring harness (see WP 0228 00 for dual voltage; 0229 00 for single voltage). If voltage is present, repair/replace wire 17 of bulkhead to APU, master relay, and rigger's lights wiring harness (see WP 0224 00 for dual voltage; 0225 00 for single voltage).

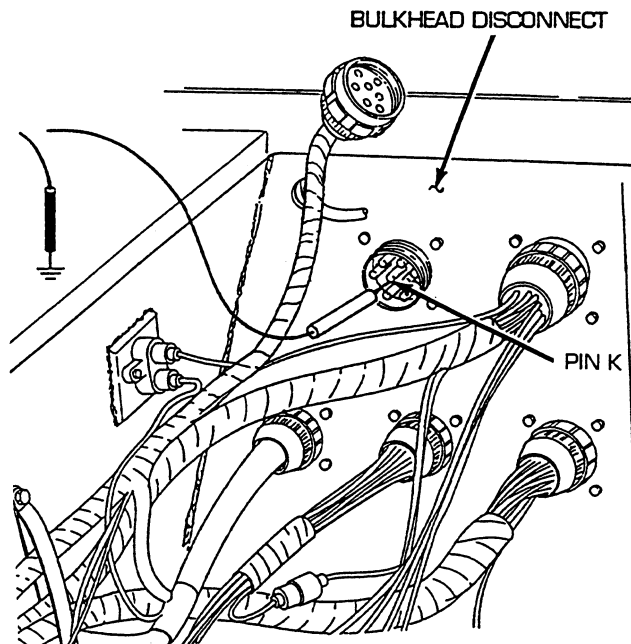

CORRECTIVE ACTION –Continued

5. Reconnect wire 17 to rigger’s SERVICE switch. Disconnect wire 16 from rigger’s SERVICE light switch. Place red lead of multimeter in wire 16 and black lead to ground. Turn MASTER switch ON, press STOP LIGHT key and ENTER key on main light switch, and check for voltage. Turn MASTER and main lighting switches OFF. If voltage is present, replace rigger’s service lights switch (see WP 0173 00). If voltage is not present, go to step 6.

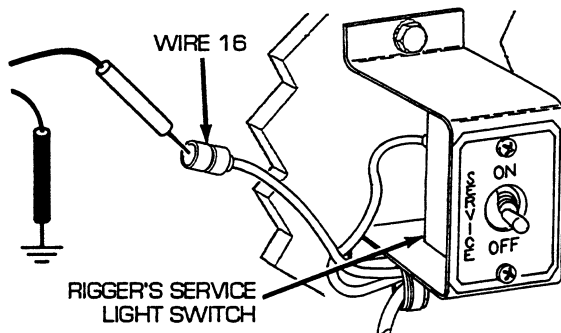

6. Reconnect wire 16 from rigger’s SERVICE light switch. Remove three screws (4), three lockwashers (5), ground lead (6), and flat washer (7) and release main switch panel (8) from mounting brackets. Disconnect switch panel to gage panel and miscellaneous switches wiring harness from main switch panel. Place a jumper wire from pin N to socket N. Place red lead of multimeter in socket D of wire 75/16 and black lead to ground. Turn MASTER switch ON, press STOP LIGHT key and ENTER key on main light switch, and check for voltage. Turn MASTER and main lighting switches OFF. If voltage is present, repair/replace wire 16/75 of switch panel to gage panel and miscellaneous switches wiring harness (see WP 0204 00 for dual voltage; 0205 00 for single voltage). If voltage is not present, go to step 7.

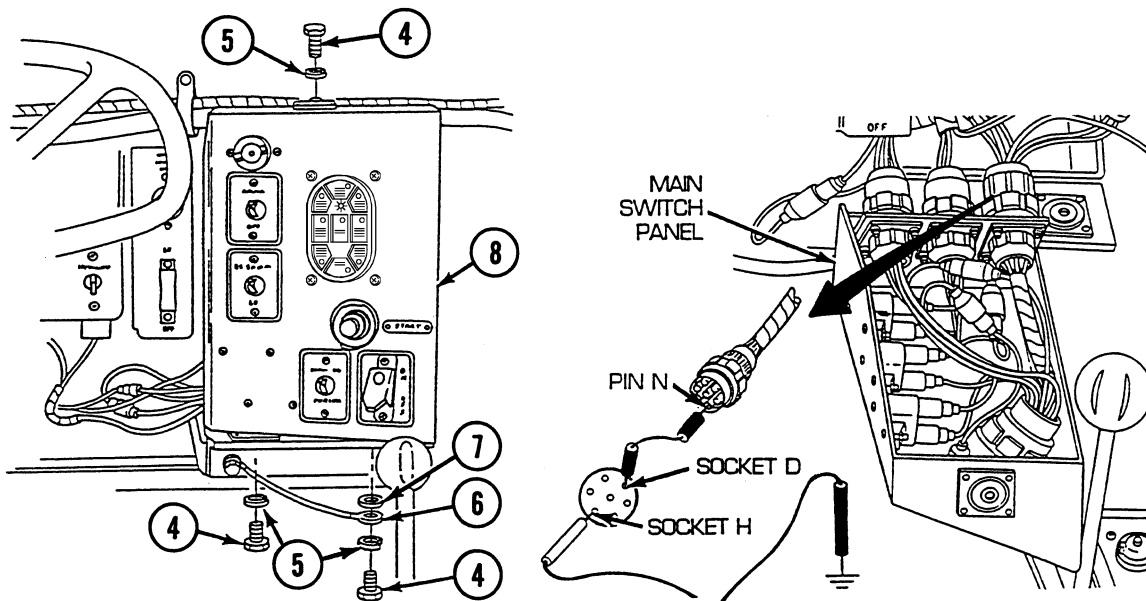

CORRECTIVE ACTION –Continued

7. Place red lead of multimeter on pin N of wire 10 and black lead to ground. Turn MASTER switch on and check for voltage. Turn MASTER switch OFF. If voltage is present, go to step 8. If voltage is not present, reconnect switch panel to gage panel and miscellaneous switches wiring harness to main switch panel and go to step 19.

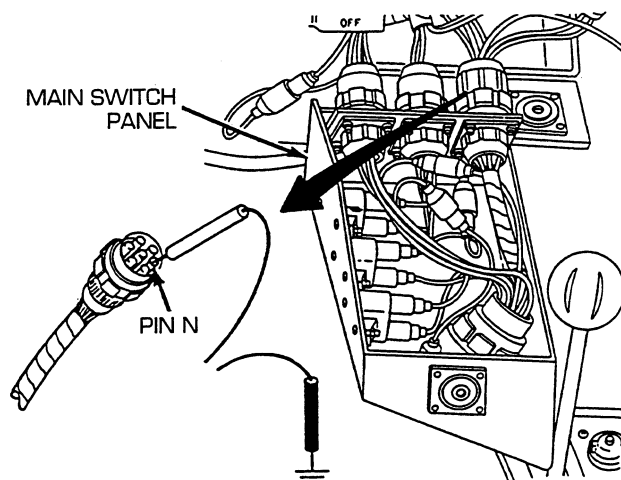

8. Reconnect switch panel to gage panel and miscellaneous switches wiring harness to main switch panel. Disconnect main lighting and master relay wiring harness from main lighting switch. Place red lead of multimeter in socket F of wire 10/15 and black lead to ground. Turn MASTER switch on and check for voltage. Turn MASTER switch OFF. If voltage is present, go to step 9. If voltage is not present, repair/replace wire 10/15 of main lighting and B.O. selector switch wiring harness (see WP 0218 00).

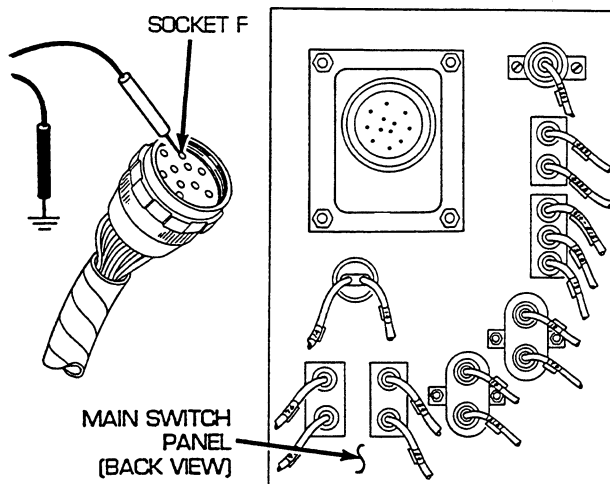

CORRECTIVE ACTION –Continued

9. UNLOCK and turn main lighting switch to SER. DRIVE. Place a jumper wire from pin F to socket F. Place red lead of multimeter on pin A of wire 75 and black lead to ground. Turn MASTER switch on and check for voltage. Turn MASTER switch OFF. If voltage is present, go to step 10. If voltage is not present, replace main lighting switch (see WP 0159 00).

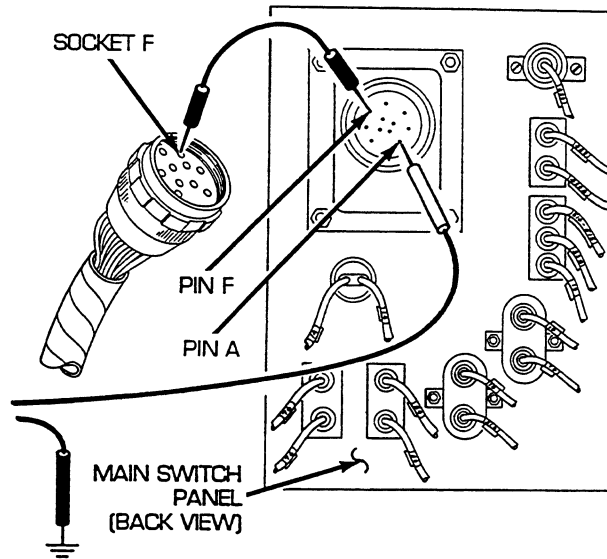

10. Reconnect main lighting and master relay wiring harness to main lighting switch. Disconnect wire 75 of main lighting and B.O. selector switch wiring harness from connector. Place red lead of multimeter on male connector of wire 75 and black lead to ground. Turn MASTER switch ON, press SER DRIVE key and ENTER key on main light switch, and check for voltage. Turn MASTER and main lighting switches OFF. If voltage is present, repair/replace wire 75 of main lighting and master relay wiring harness (see WP 0219 00). If voltage is not present, repair/replace wire 75 of main lighting and B.O. selector switch wiring harness (see WP 0218 00).

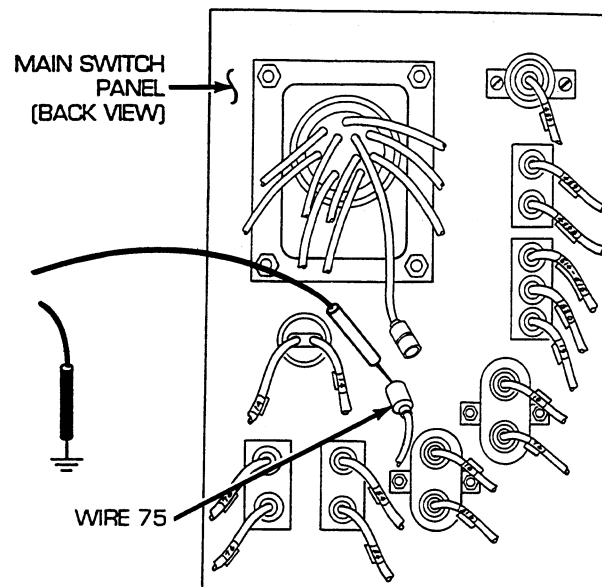

CORRECTIVE ACTION –Continued

11. Loosen three screws (9) and remove light door with lamp (10). Place red lead of multimeter in connector and black lead to ground. Turn MASTER and FLASHER switches on and check for voltage. Turn MASTER and FLASHER switches OFF. If voltage is present, replace lamp (see WP 0177 00). If voltage is not present, go to step 12.

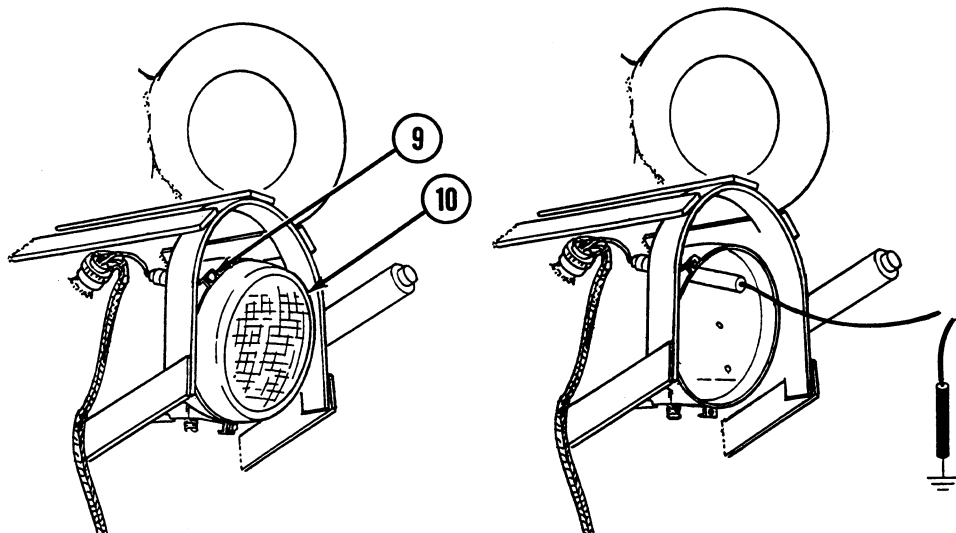

12. Install light door with lamp (10) and tighten three screws (9). Disconnect wire 325 from front signal light. Place red lead of multimeter in wire 325 and black lead to ground. Turn MASTER and FLASHER switches ON and check for voltage. Turn MASTER and FLASHER switches OFF. If voltage is present, replace front signal light assembly (see WP 0177 00). If voltage is not present, go to step 13.

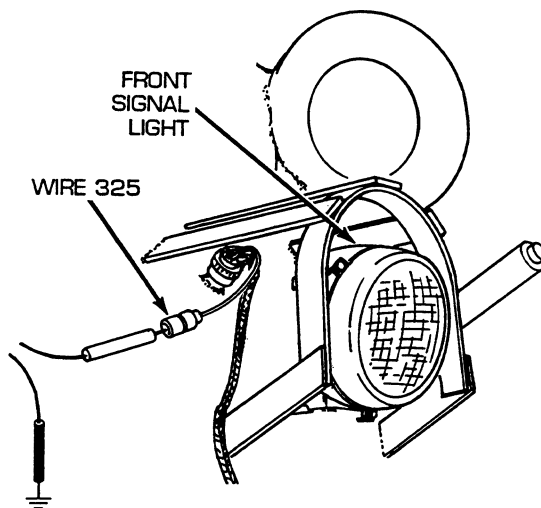

CORRECTIVE ACTION –Continued

13. Disconnect wire 325 from indicator light. Place red lead of multimeter in wire 325 and black lead to ground. Turn MASTER and FLASHER switches ON and check for voltage. Turn MASTER and FLASHER switches OFF. If voltage is present, replace indicator lamp (see WP 0160 00). If voltage is not present, go to step 14.

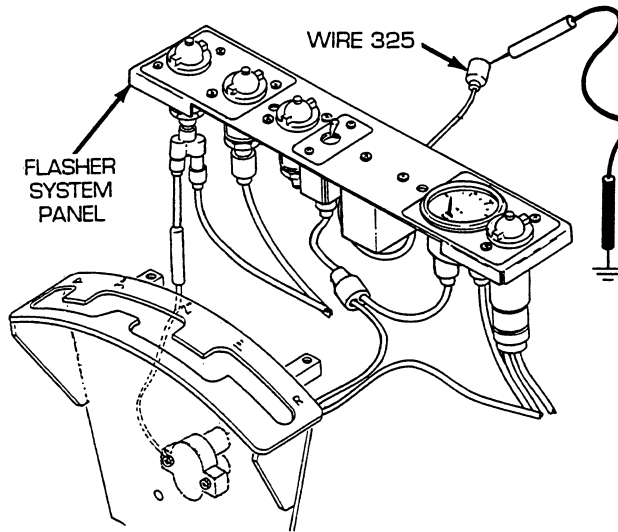

14. Disconnect turn signal flasher wiring harness from flasher unit. Place red lead of multimeter in socket B of wire 325 and black lead to ground. Turn MASTER and FLASHER switches ON and check for voltage. Turn MASTER and FLASHER switches OFF. If voltage is present, replace flasher unit (see WP 0160 00). If voltage is not present, go to step 15.

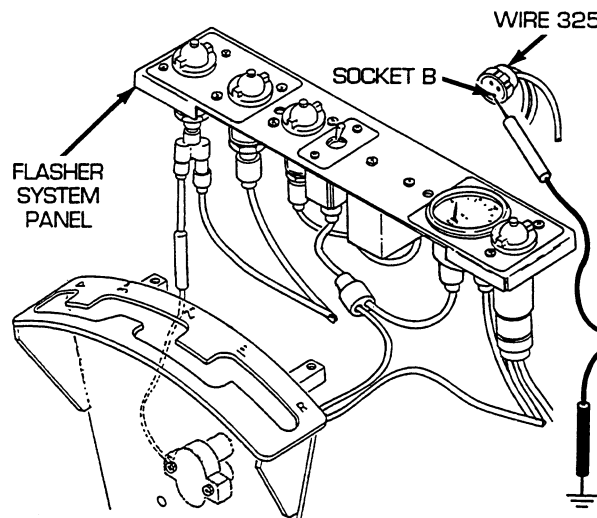

CORRECTIVE ACTION –Continued

15. Reconnect turn signal flasher wiring harness to flasher unit. Disconnect wire 325 from flasher side of FLASHER switch. Place red lead of multimeter on terminal of switch and black lead to ground. Turn MASTER and FLASHER switches ON and check for voltage. Turn MASTER and FLASHER switches OFF. If voltage is not present, go to step 16. If voltage is present, repair/replace wire 325 of turn signal flasher wiring harness from FLASHER switch to the flasher (see WP 0216 00).

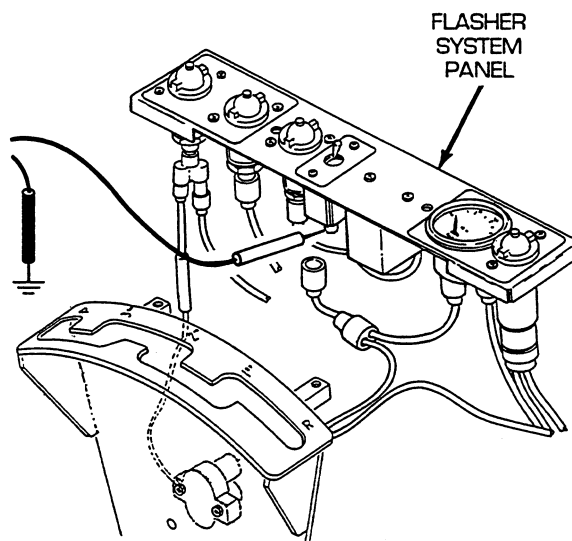

16. Reconnect wire 325 to flasher side of FLASHER switch. Disconnect wire 325 of red flasher breaker to switch wiring harness from circuit breaker side of FLASHER switch. Place red lead of multimeter in of wire 325 and black lead to ground. Turn MASTER switch on and check for voltage. Turn MASTER switch OFF. If voltage is present, replace FLASHER switch (see WP 0160 00). If voltage is not present, go to step 17.

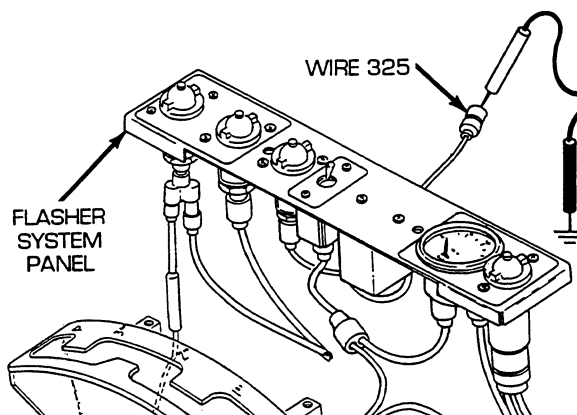

CORRECTIVE ACTION –Continued

17. Reconnect wire 325 of red flasher breaker to switch cable to circuit breaker side FLASHER switch. Disconnect wire 325 from FLASHER switch side of 15 A circuit breaker. Place red lead of multimeter on circuit breaker terminal and black lead to ground. Turn MASTER switch on and check for voltage. Turn MASTER switch OFF. If voltage is present, repair/replace wire 325 of red flasher breaker to switch wiring harness from 15 A circuit breaker to FLASHER switch (see WP 0215 00). If voltage is not present, go to step 18.

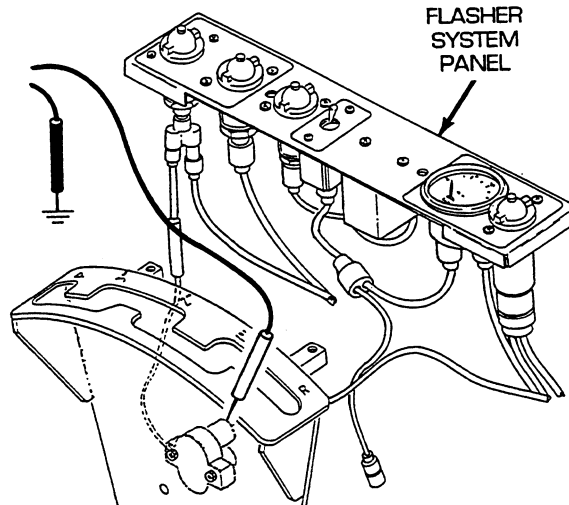

18. Reconnect wire 325 of red flasher breaker to switch wiring harness to switch side of 15 A circuit breaker. Disconnect wire 325 of switch panel, radio and bilge pump to bulkhead wiring harness from main switch panel side of 15 A circuit breaker. Place red lead of multimeter in wire 325 and black lead to ground. Turn MASTER switch on and check for voltage. Turn MASTER switch OFF. If voltage is present, replace 15 A circuit breaker (see WP 0160 00). If voltage is not present, reconnect wire 325 of switch panel, radio, and bilge pump to bulkhead wiring harness to main switch panel side of 15 A circuit breaker.

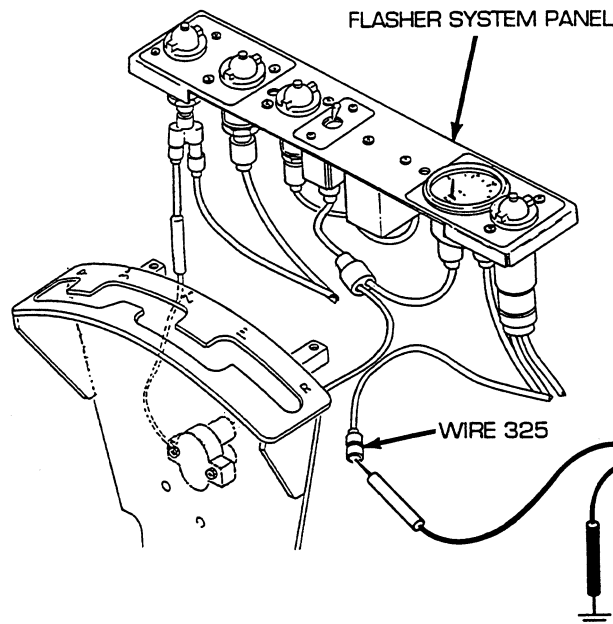

CORRECTIVE ACTION –Continued

19. Install main switch panel (8), flat washer (7), ground lead (6), three lockwashers (5), and three screws (4). Open air inlet doors (TM 9-2350-256-10). Disconnect wire 48 pin A from bulkhead to master relay wiring harness. Place red multimeter lead in socket and black lead to ground. Turn MASTER switch on and check for voltage. If voltage is present, repair/replace switch panel, radio, and bilge pump to bulkhead wiring harness (see WP 0202 00). If voltage is not present, troubleshoot master relay circuit (see WP 0042 00).

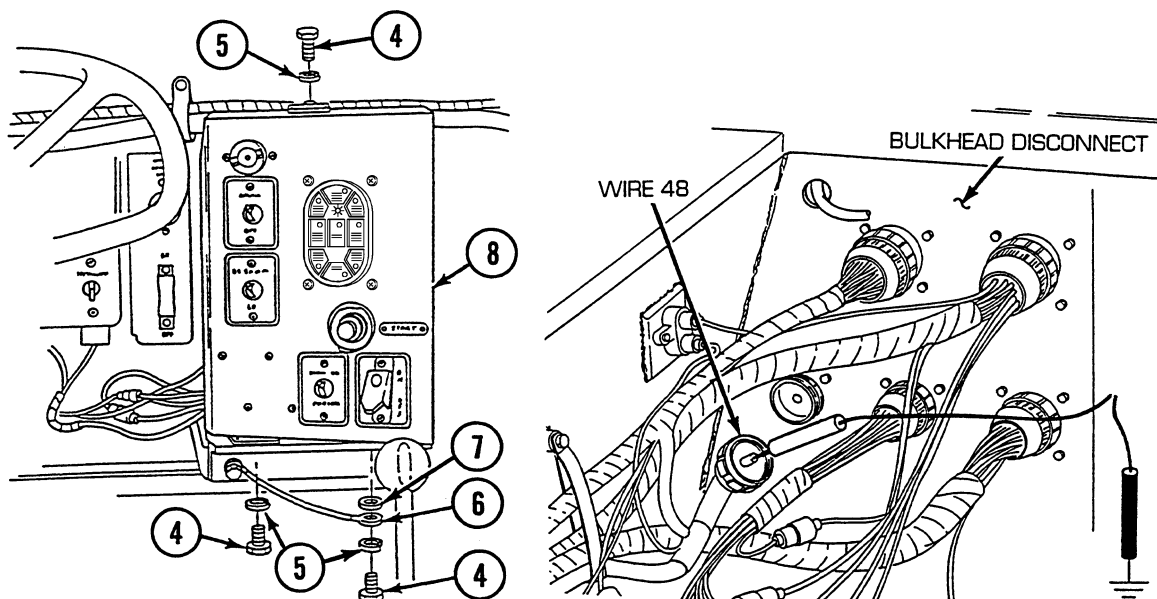
**END OF WORK PACKAGE**

UNIT MAINTENANCE
RECOVERY VEHICLE, FULL TRACKED: MEDIUM, M88A1
NSN 2350-00-122-6826, EIC AQA
VENTILATION BLOWER SYSTEM TROUBLESHOOTING PROCEDURE

INITIAL SETUP:**Tools and Special Tools**

Tool kit, general mechanic's (item 59, WP 0490 00)

References

WP 0042 00
WP 0158 00

References (cont.)

WP 0196 00
WP 0202 00
WP 0233 00
WP 0250 00
TM 9-2350-256-10

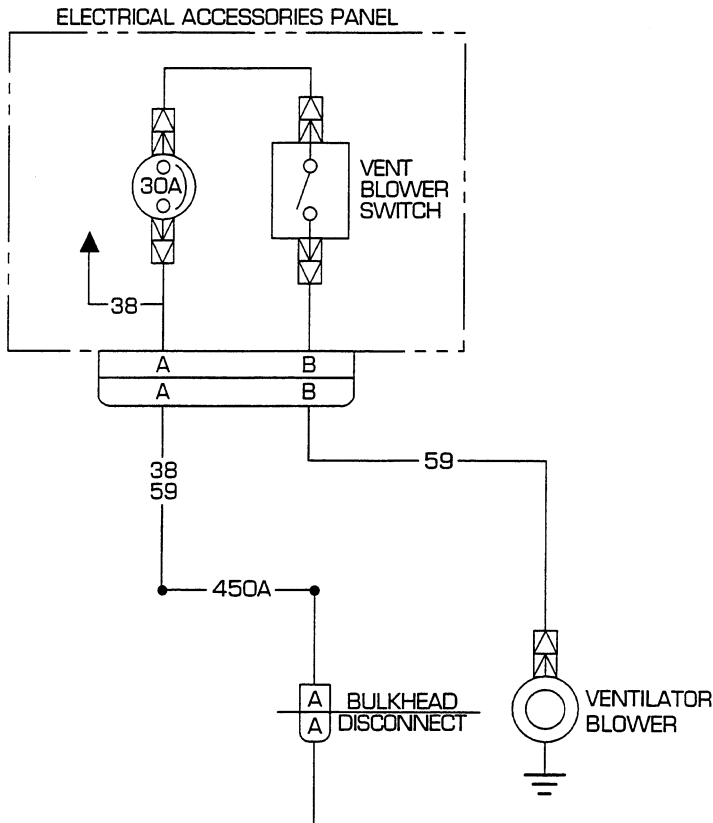
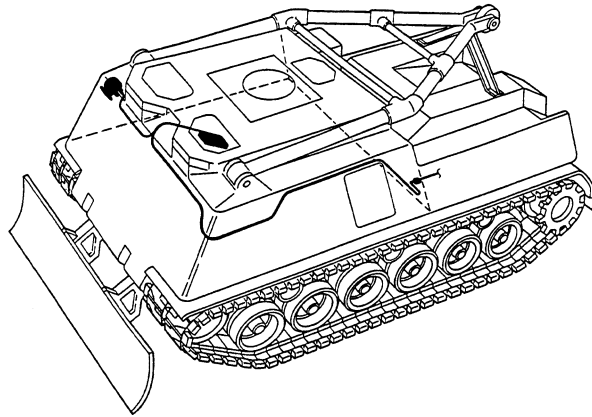

Troubleshooting Procedure

Ventilation Blower System

Symptom

Ventilation blower malfunctioning.

Malfunction

Ventilation blower fails to operate. Do steps 1 thru 8.

CORRECTIVE ACTION

WARNING

Remove all jewelry such as rings, dog tags, bracelets, etc. If jewelry contacts a metal surface a direct short may result in instant heating of tools, damage to equipment, and injury or death to personnel.

1. Disconnect electrical accessories panel wiring harness from electrical accessories panel. Place red lead of multimeter in socket A of wire 38/59 and black lead to ground. Turn MASTER switch on and check for voltage. Turn MASTER switch OFF. If voltage is present, go to step 2. If voltage is not present, go to step 8.

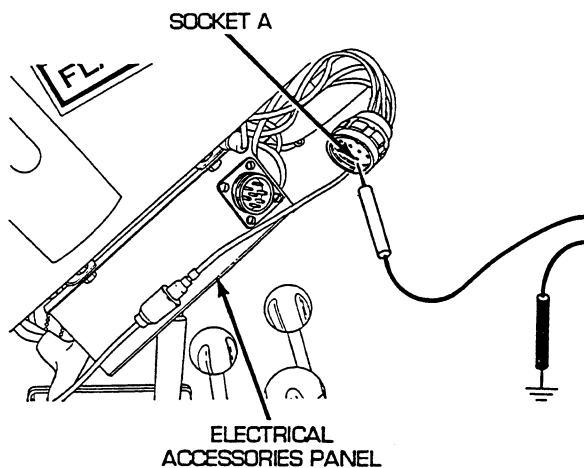

2. Place a jumper wire from socket A to pin A. Place red lead of multimeter on pin B of wire 59 and black lead to ground. Turn MASTER and VENT BLOWER switches ON and check for voltage. Turn MASTER and VENT BLOWER switches OFF. If voltage is present, go to step 7. If voltage is not present, go to step 3.

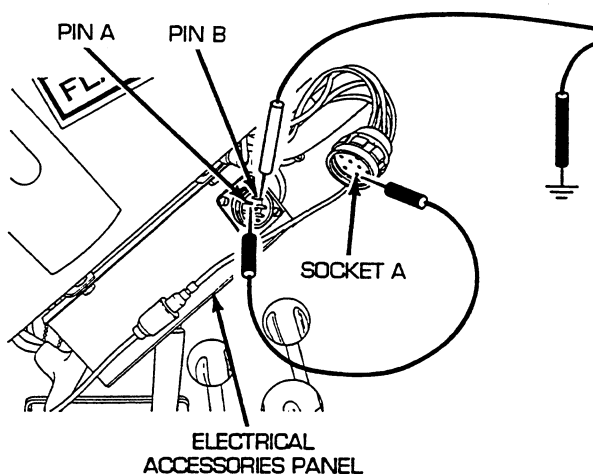

CORRECTIVE ACTION –Continued

3. Remove four screws (1) and four lockwashers (2) and release electrical accessories panel (3) from mounting brackets. Ground panel. Reconnect electrical accessories panel wiring harness to electrical accessories panel. Disconnect wire 38/59 from 15 A circuit breaker. Place red lead of multimeter in wire 38/59 and black lead to ground. Turn MASTER switch on and check for voltage. Turn MASTER switch OFF. If voltage is present, go to step 4. If voltage is not present, repair/replace wire 38/59 of bilge pump main power wiring harness (see WP 0233 00).

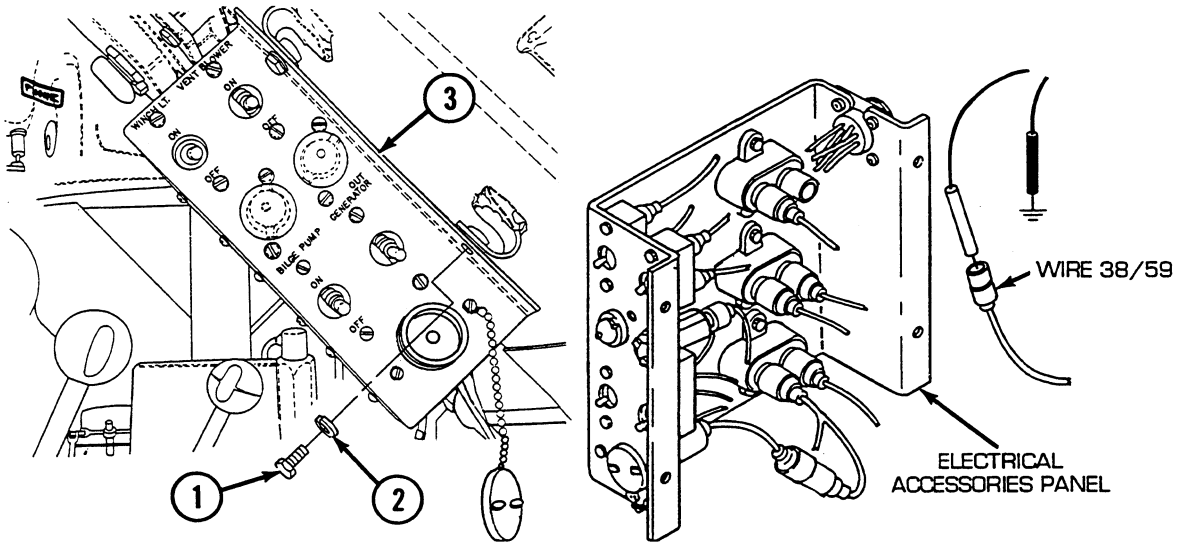

4. Reconnect wire 38/59 to 15 A circuit breaker. Disconnect wire 59 from blower switch side of 15 A circuit breaker. Place red lead of multimeter on terminal of 15 A circuit breaker and black lead to ground. Turn MASTER switch on and check for voltage. Turn MASTER switch OFF. If voltage is present, go to step 5. If voltage is not present, replace 15 A circuit breaker (see WP 0158 00).

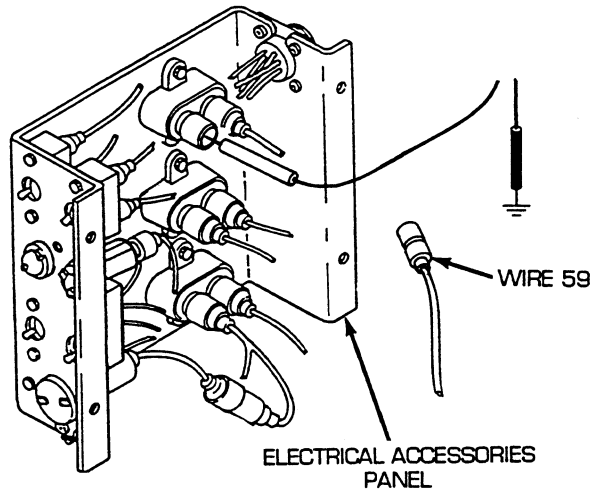

CORRECTIVE ACTION –Continued

5. Reconnect wire 59 to blower switch side of 15 A circuit breaker. Disconnect wire 59 from circuit breaker side of blower switch. Place red lead of multimeter in wire 59 and black lead to ground. Turn MASTER switch on and check for voltage. Turn MASTER switch OFF. If voltage is present, go to step F. If voltage is not present, repair/replace wire 59 of ventilation blower switch lead assembly (see WP 0158 00).

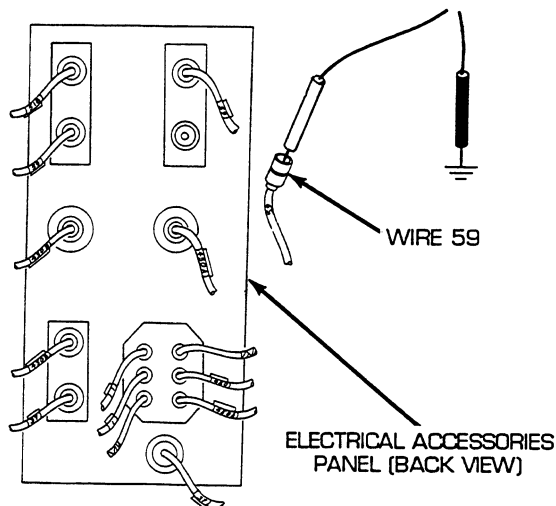

6. Reconnect wire 59 to 15 A circuit breaker side of blower switch. Disconnect wire 59 from panel connector side of blower switch. Place red lead of multimeter on terminal of blower switch and black lead to ground. Turn MASTER and VENT BLOWER switches ON and check for voltage. Turn MASTER and VENT BLOWER switches OFF. If voltage is present, repair/replace wire 59 of bilge pump main power wiring harness (see WP 0233 00). If voltage is not present, replace ventilator blower switch (see WP 0158 00).

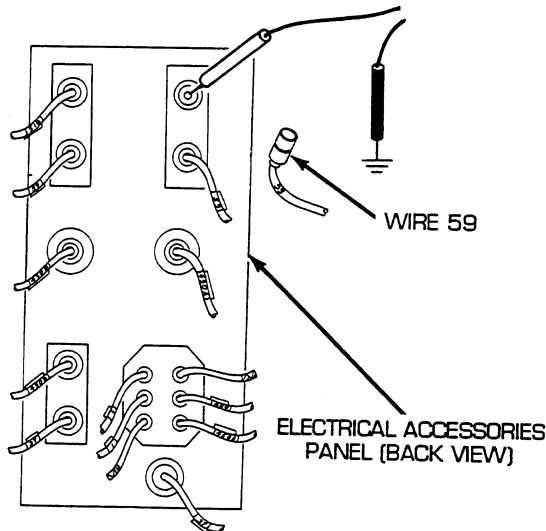

CORRECTIVE ACTION –Continued

7. Reconnect electrical accessories panel wiring harness to electrical accessories panel. Disconnect wire 59 from ventilation blower. Place red lead of multimeter in wire 59 and black lead to ground. Turn MASTER and VENT BLOWER switches ON and check for voltage. Turn MASTER and VENT BLOWER switches OFF. If voltage is present, repair/replace ventilation blower (see WP 0250 00). If voltage is not present, repair/replace wire 59 of electrical accessories panel wiring harness (see WP 0196 00).

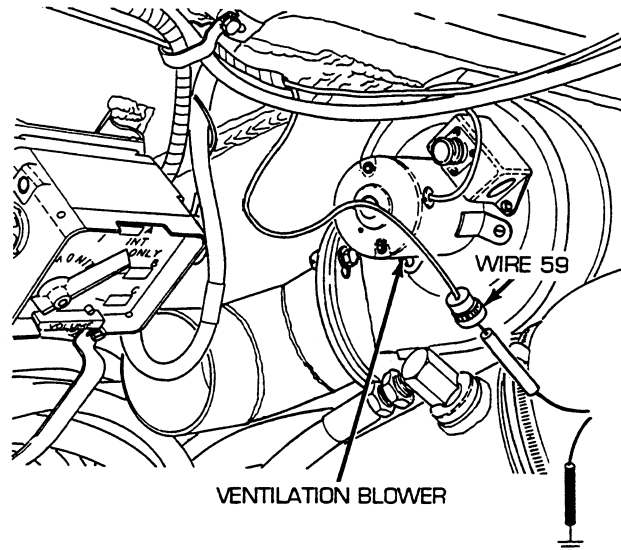

8. Reconnect electrical accessories panel wiring harness to electrical accessories panel. Open air inlet doors (TM 9-2350-256-10). Disconnect wire 48 pin A from bulkhead to master relay wiring harness. Place red multimeter lead in socket and black lead to ground. Turn MASTER switch on and check for voltage. Turn MASTER switch OFF. If voltage is present, repair/replace switch panel, radio, and bilge pump to bulkhead wiring harness (see WP 0202 00). If voltage is not present, troubleshoot master relay circuit (see WP 0042 00).

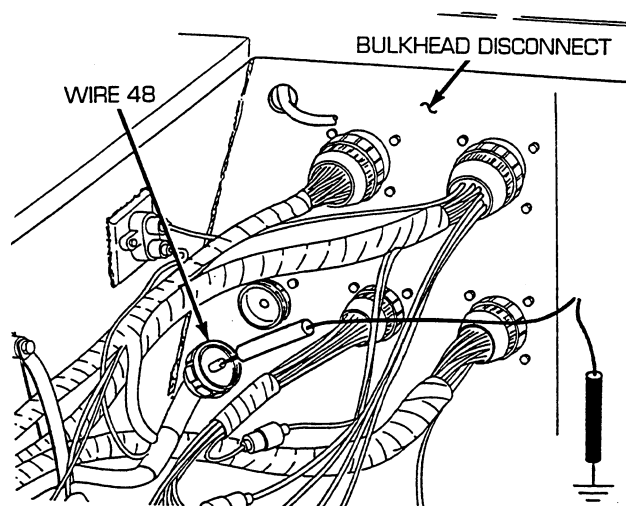

END OF WORK PACKAGE

UNIT MAINTENANCE
RECOVERY VEHICLE, FULL TRACKED: MEDIUM, M88A1
NSN 2350-00-122-6826, EIC AQA

ENGINE GENERATOR BLOWER MOTOR TROUBLESHOOTING PROCEDURE

INITIAL SETUP:

Tools and Special Tools

Tool kit, general mechanic's (item 59, WP 0490 00)

References (cont.)

WP 0099 00

WP 0150 00

WP 0207 00

WP 0208 00

References

WP 0098 00

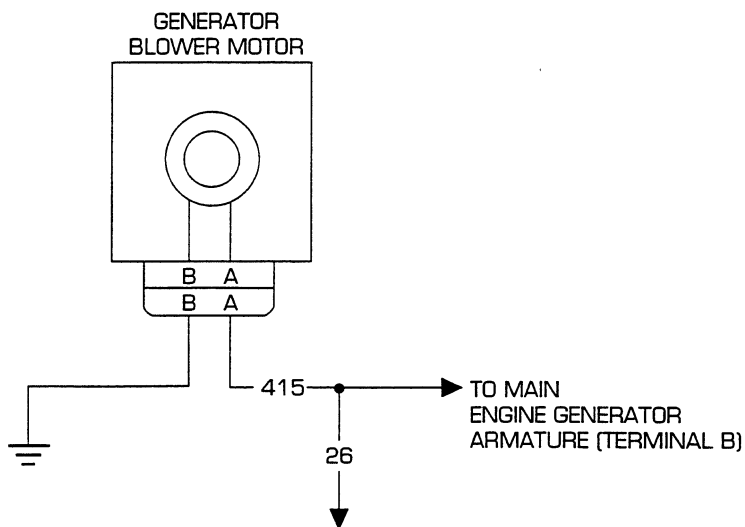
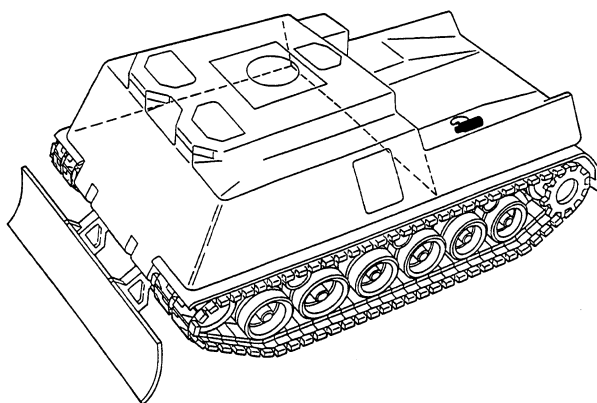

Troubleshooting Procedure

Engine Generator Blower Motor

Symptom

Engine generator blower malfunctioning.

Malfunction

Engine generator blower motor fails to operate when engine is running. Do steps 1 and 2.

CORRECTIVE ACTION

WARNING

Remove all jewelry such as rings, dog tags, bracelets, etc. If jewelry contacts a metal surface a direct short may result in instant heating of tools, damage to equipment, and injury or death to personnel.

1. Remove powerplant and connect groundhop kit (see WP 0098 00 and 0099 00). Disconnect engine wiring harness from engine blower motor. Place red lead of multimeter in socket A of wire 415 and black lead to ground. Turn MASTER switch on, start engine, and check for voltage. Turn engine and MASTER switch OFF. If voltage is present, go to step 2. If voltage is not present, repair/replace wire 415 of engine wiring harness from blower plug to generator armature terminal (see WP 0207 00 for dual voltage; 0208 00 for single voltage).
2. Place red lead of multimeter in socket B of GND wire and black lead to GND. Check for continuity. If continuity is present, repair/replace engine generator blower motor (see WP 0150 00). If continuity is not present, repair/replace ground wire of engine wiring harness (see WP 0207 00 for dual voltage; 0208 00 for single voltage).

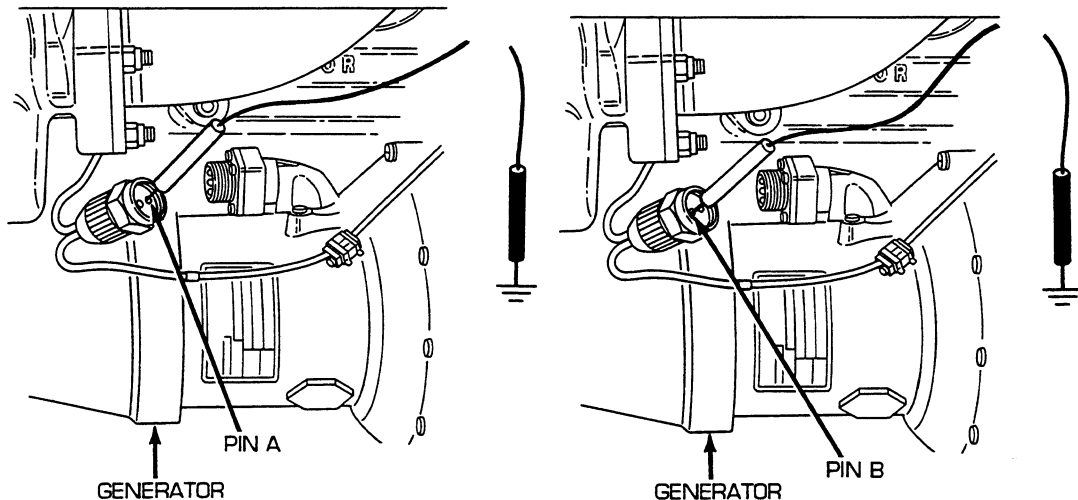

END OF WORK PACKAGE

UNIT MAINTENANCE
RECOVERY VEHICLE, FULL TRACKED: MEDIUM, M88A1
NSN 2350-00-122-6826, EIC AQA

M8A3 FILTER UNIT SYSTEM TROUBLESHOOTING PROCEDURE

INITIAL SETUP:

Tools and Special Tools

Tool kit, general mechanic's (item 59, WP 0490 00)

References

WP 0439 00
 WP 0441 00

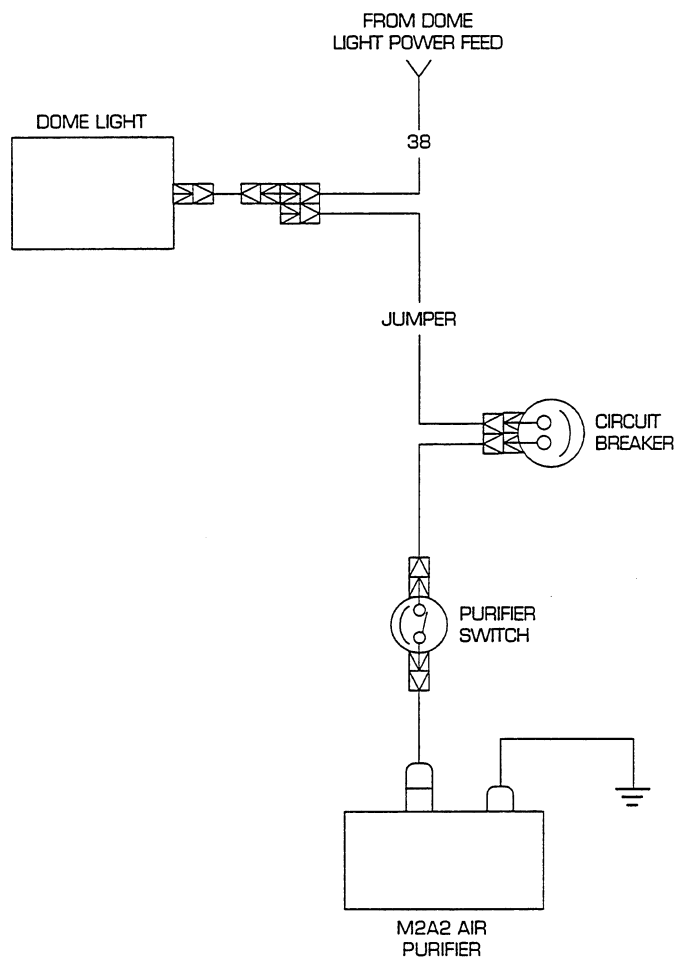
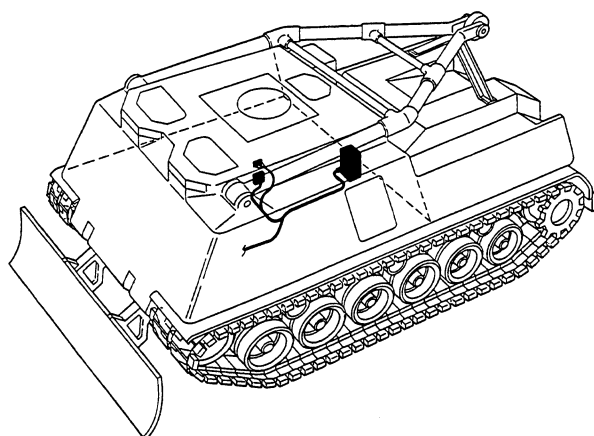

Troubleshooting Procedure

M8A3 Filter Unit System

Symptom

M8A3 filter unit system malfunctioning.

Malfunction

M2A2 air purifier fails to operate. Do steps 1 thru 7.

CORRECTIVE ACTION

WARNING

Remove all jewelry such as rings, dog tags, bracelets, etc. If jewelry contacts a metal surface a direct short may result in instant heating of tools, damage to equipment, and injury or death to personnel.

NOTE

There are two air purifiers in the M88A1. Troubleshooting is the same for each.

1. Place red lead of multimeter to bare metal surface of M2A2 air purifier and black lead to ground. If continuity is present, go to step 2. If continuity is not present, repair/replace ground wire.
2. Disconnect wire from M2A2 air purifier. Place red lead of multimeter in wire and black lead to ground. Turn MASTER and purifier switches on and check for voltage. Turn MASTER and purifier switches OFF. If voltage is present, repair/replace M2A2 air purifier (see WP 0439 00). If voltage is not present, go to step 3.

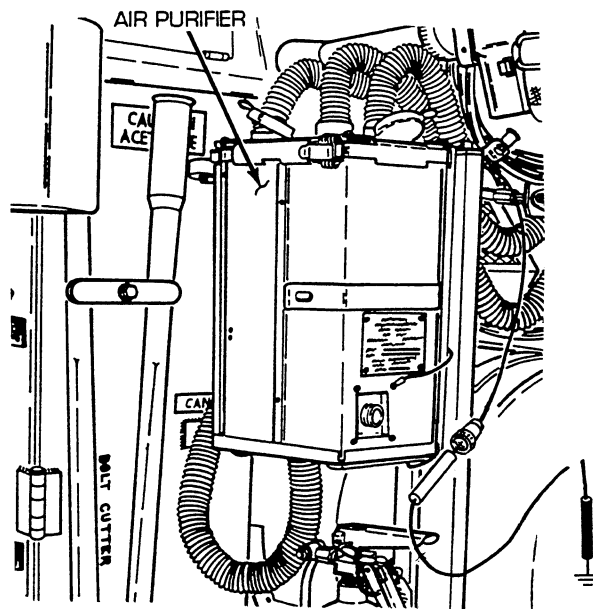

CORRECTIVE ACTION –Continued

3. Reconnect wire to M2A2 air purifier. Disconnect wire from purifier side of purifier switch. Place red lead of multimeter on switch terminal and black lead to ground. Turn MASTER and purifier switches on and check for voltage. Turn MASTER and purifier switches OFF. If voltage is present, repair/replace wire (see WP 0439 00). If voltage is not present, go to step 4.

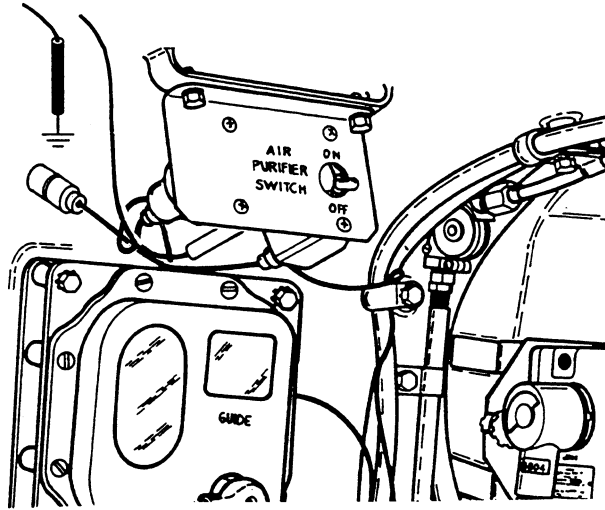

4. Reconnect wire to purifier switch. Disconnect wire from circuit breaker side of purifier switch. Place red lead of multimeter in wire and black lead to ground. Turn MASTER switch on and check for voltage. Turn MASTER switch OFF. If voltage is present, replace purifier switch (see WP 0441 00). If voltage is not present, go to step 5.

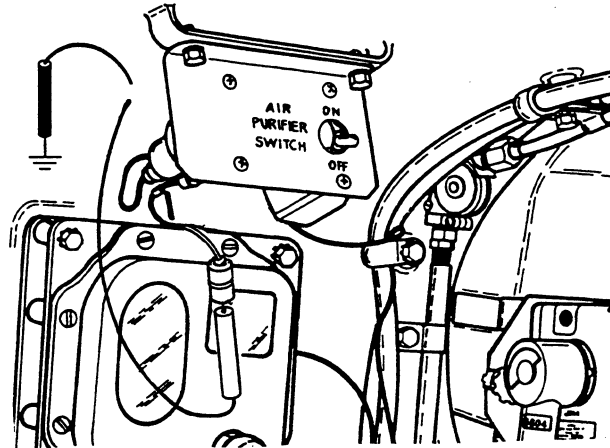

CORRECTIVE ACTION –Continued

5. Reconnect wire to purifier switch. Disconnect wire from switch side of circuit breaker. Place red lead of multimeter on circuit breaker terminal and black lead to ground. Turn MASTER switch on and check for voltage. Turn MASTER switch OFF. If voltage is present, repair/replace wire from purifier switch to circuit breaker (see WP 0439 00). If voltage is not present, go to step 6.

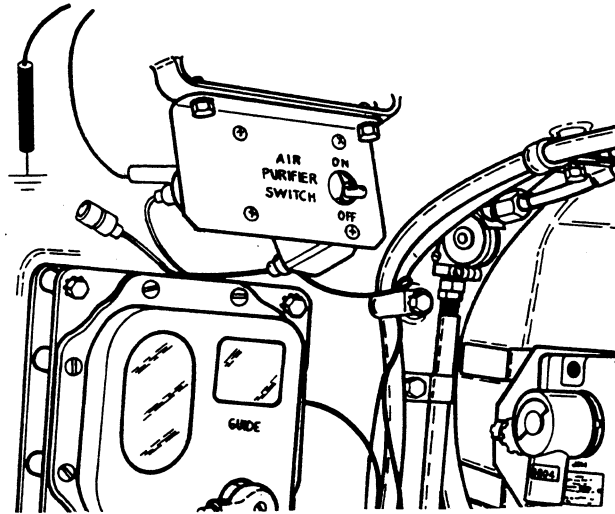

6. Reconnect wire to switch side of circuit breaker. Disconnect wire from dome light side of circuit breaker. Place red lead of multimeter in wire and black lead to ground. Turn MASTER switch on and check for voltage. Turn MASTER switch OFF. If voltage is present, replace circuit breaker (see WP 0441 00). If voltage is not present, go to step 7.

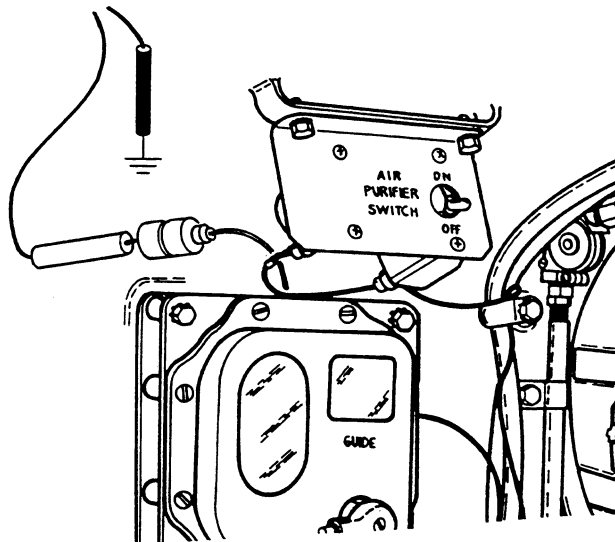

CORRECTIVE ACTION –Continued

7. Reconnect wire to dome light side of circuit breaker. Disconnect wire from Y-connector. Place red lead of multimeter in Y-connector and black lead to ground. Turn MASTER switch on and check for voltage. Turn MASTER switch OFF. If voltage is present, repair/replace Y-connector (see WP 0439 00). If voltage is not present, troubleshoot dome light circuit.

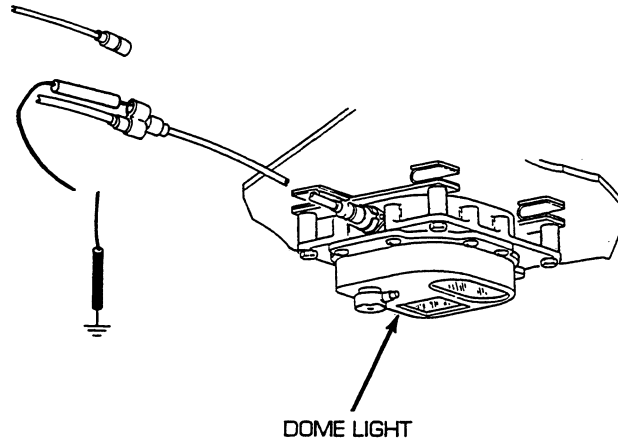
**END OF WORK PACKAGE**

UNIT MAINTENANCE
RECOVERY VEHICLE, FULL TRACKED: MEDIUM, M88A1
NSN 2350-00-122-6826, EIC AQA

M239 SMOKE GRENADE LAUNCHER SYSTEM TROUBLESHOOTING PROCEDURE

INITIAL SETUP:

Tools and Special Tools

Tool kit, general mechanic's (item 59, WP 0490 00)

References

WP 0240 00

WP 0241 00

References (cont.)

WP 0253 00

WP 0442 00

TM 3-1040-266-20&P

TM 9-1330-200-12

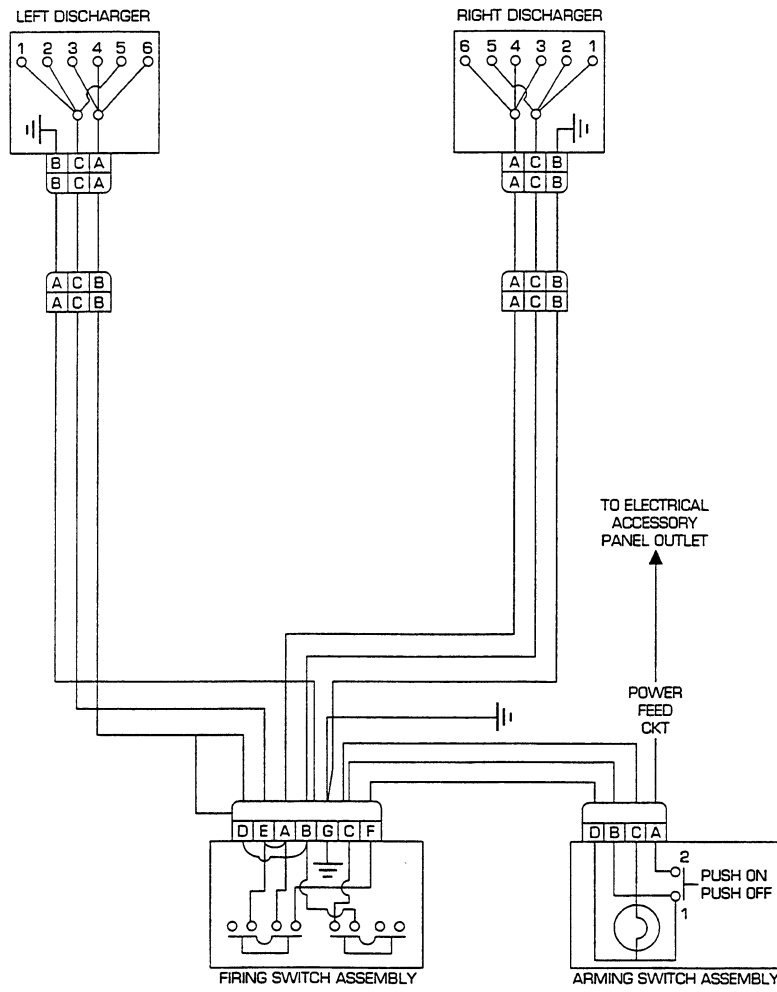
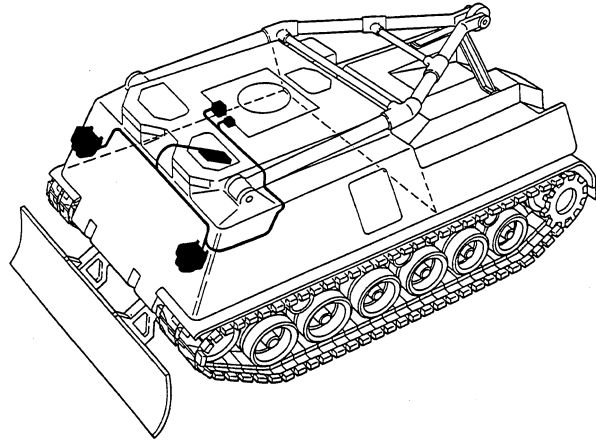

Troubleshooting Procedure

M239 Smoke Grenade Launcher System

Symptom

M239 smoke grenade launcher system malfunctioning.

Malfunction

One or more of the launcher tubes fails to operate. Do steps 1 thru 10.

CORRECTIVE ACTION

WARNING

Ensure all launcher tubes are empty before performing maintenance on launcher system. Serious injury or death may result if tubes launch accidentally.

WARNING

Remove all jewelry such as rings, dog tags, bracelets, etc. If jewelry contacts a metal surface a direct short may result in instant heating of tools, damage to equipment, and injury or death to personnel.

1. Remove lens from lamp on M239 launcher power switch box assembly. Remove lamp. Place red lead of multimeter in lamp socket and black lead to ground. Turn MASTER and ARM SMOKE switches ON and check for voltage. Turn MASTER and ARM SMOKE switches OFF. If voltage is present, replace lamp (see WP 0442 00). If voltage is not present, go to step 2.

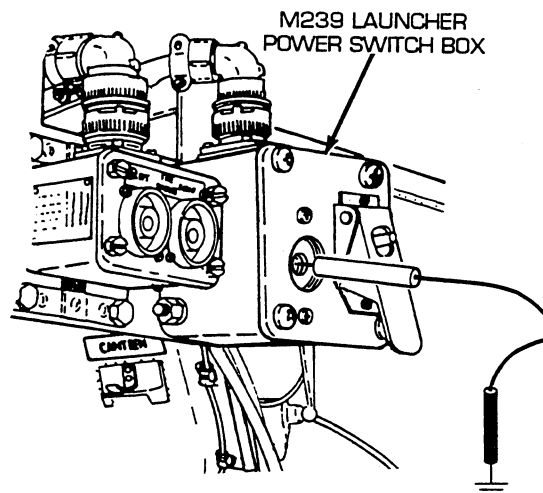

CORRECTIVE ACTION –Continued

2. Disconnect smoke grenade launcher system wiring harness from M239 launcher power switch box. Place red lead of multimeter in socket A of harness and black lead to ground. Turn MASTER switch on and check for voltage. Turn MASTER switch OFF. If voltage is present, go to step 4. If voltage is not present, go to step 3.

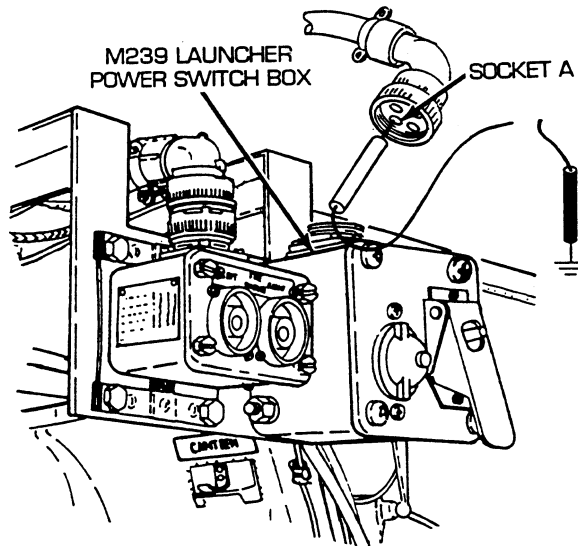

3. Place red lead of multimeter in accessory panel outlet and black lead to ground. Turn MASTER switch on and check for voltage. Turn MASTER switch OFF. If voltage is present, repair/replace wire from accessory outlet to arming switch assembly of smoke grenade launcher system wiring (see WP 0240 00). If voltage is not present, troubleshoot bilge pump system and electrical accessories panel power outlet.

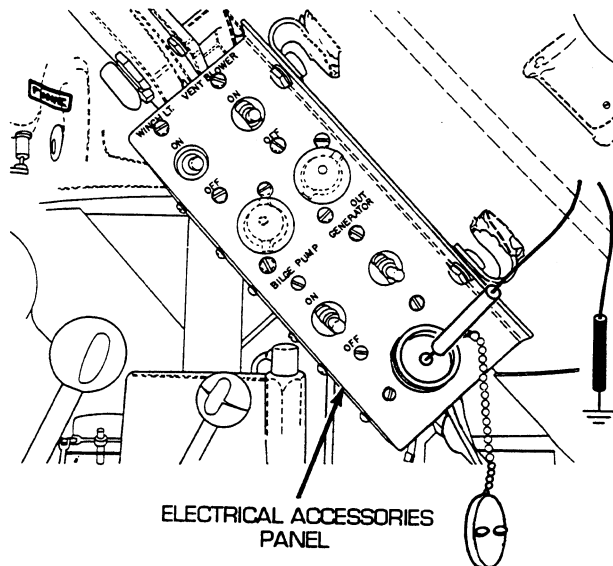

CORRECTIVE ACTION –Continued

4. Place a jumper wire from pin A to socket A. Place red lead of multimeter on pin B of M239 launcher power switch box and black lead to ground. Turn MASTER and ARM SMOKE switches ON and check for voltage. Place red lead of multimeter on pin D of ARM SMOKE box assembly and black lead to ground and check for voltage. Turn MASTER and ARM SMOKE switches OFF. If voltage is present on both pins, go to step 6. If voltage is not present on either pin, go to step 5.

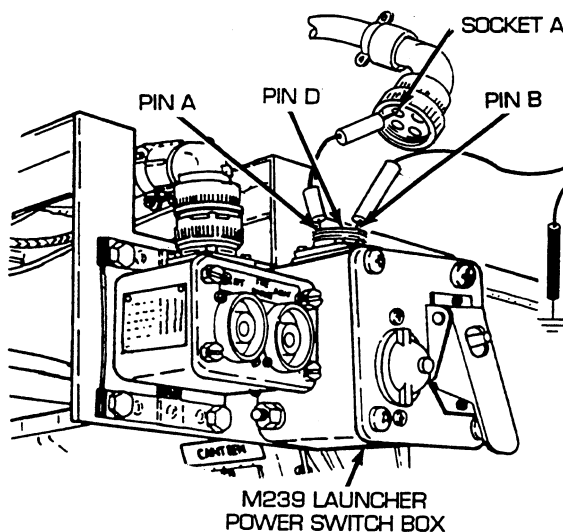

5. Reconnect smoke grenade launcher system wiring harness to M239 launcher power switch box. Remove M239 launcher power switch box from mounting bracket (see WP 0442 00). Disconnect connector from terminal 2 of ARM SMOKE switch. Place red lead of multimeter on wiring harness and black lead to ground. Turn MASTER switch on and check for voltage. Turn MASTER switch OFF. If voltage is not present, repair/replace wire in power switch box assembly for M239 smoke grenade launcher assembly (see WP 0241 00). If voltage is present, replace ARM SMOKE switch (see WP 0442 00).

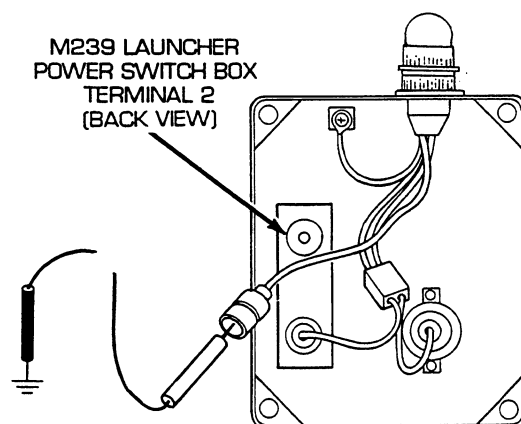

CORRECTIVE ACTION –Continued

6. Reconnect smoke grenade launcher system wiring harness to M239 launcher power switch box. Disconnect smoke grenade launcher system wiring harness from FIRE SMOKE box assembly. Place red lead of multimeter in socket B and black lead to ground. Turn MASTER and ARM SMOKE switches ON and check for voltage. Place red lead of multimeter in socket D and black lead to ground and check for voltage. Turn MASTER and ARM SMOKE switches OFF. If voltage is present in both sockets, go to step 7. If voltage is not present in either socket, repair/replace smoke grenade launcher system wiring harness (see WP 0240 00).

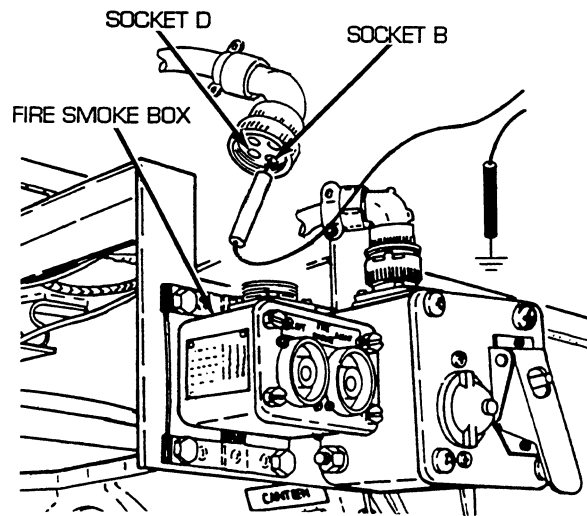

CORRECTIVE ACTION –Continued

7. Remove screw securing ground wire. Check ground wire for continuity by placing red lead of multimeter in socket G and black lead on ground wire terminal. If continuity is present, go to step 8. If continuity is not present, repair/replace ground wire of smoke grenade launcher system wiring harness (see WP 0241 00).

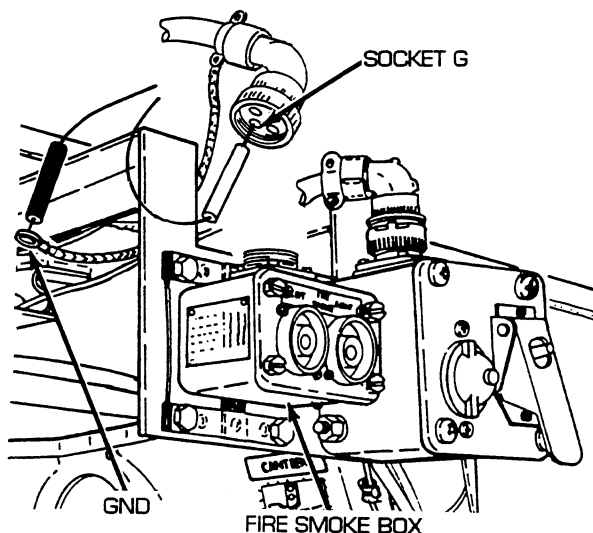

8. Reconnect ground wire. Place jumper wires from pin G to socket G and from pin C to socket C. Place red lead of multimeter on pin B and black lead to ground. Turn MASTER and ARM SMOKE switches ON, push RIGHT switch, and check for voltage. Turn MASTER and ARM SMOKE switches OFF. If voltage is present, go to step 9 for right dischargers, and step 10 for left dischargers. If voltage is not present, replace FIRE SMOKE box assembly (refer to TM 3-1040-266-20&P).

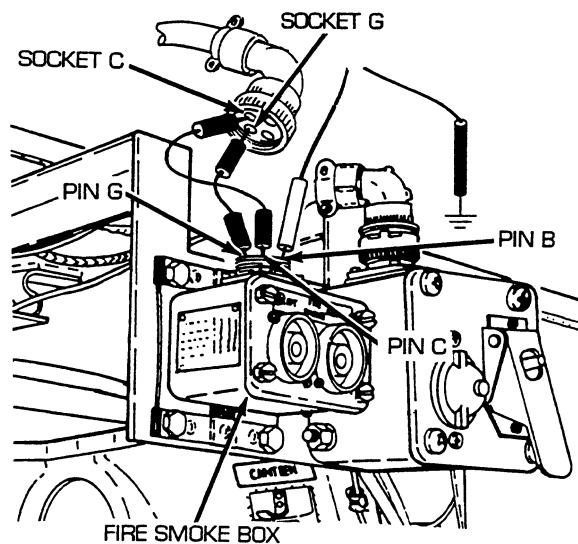

CORRECTIVE ACTION –Continued**CAUTION**

The following steps apply to both the LEFT and RIGHT dischargers. The LEFT and RIGHT firing buttons fire three grenades from each side at the same time. Failure to do all the steps could leave inoperative firing on some tubes.

9. Reconnect smoke grenade launcher system wiring harness to FIRE SMOKE box assembly. Disconnect cable assembly for M239 smoke grenade launcher, right hand side discharger feed through from grenade launcher assembly. Place red lead of multimeter in socket C and black lead to ground. Turn MASTER and ARM SMOKE switches ON, push RIGHT switch, and check for voltage. Turn MASTER and ARM SMOKE switches OFF. Check ground circuit for continuity by placing red lead of multimeter in socket B and black lead to ground. If voltage and continuity are present in all circuits, notify Direct Support Maintenance. If voltage or continuity is not present in any circuit, repair/replace harness cable assembly for M239 smoke grenade launcher right hand side discharger feed through, (see WP 0253 00).

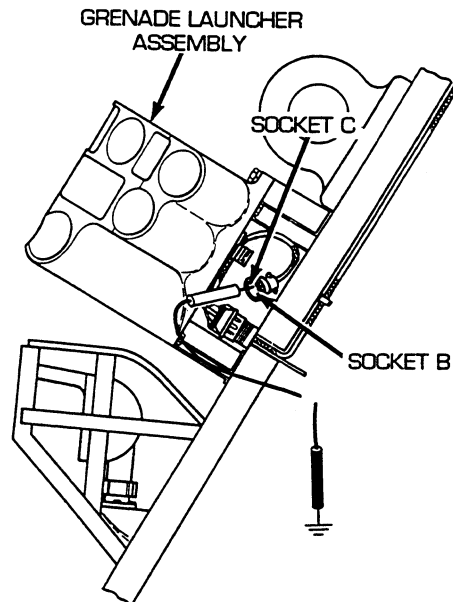

CORRECTIVE ACTION –Continued

10. Reconnect smoke grenade launcher system wiring harness to FIRE SMOKE box assembly. Disconnect cable assembly for M239 smoke grenade launcher, left hand side discharger feed through from launcher assembly. Place red lead of multimeter in socket A and black lead to ground. Turn MASTER and ARM SMOKE switches ON, push LEFT switch, and check for voltage. Turn MASTER and ARM SMOKE switches OFF. Check ground circuit for continuity by placing red lead of multimeter in socket B and black lead to ground. If voltage and continuity are present in all circuits, refer to TM 9-1330-200-12. If voltage or continuity is not present in any circuit, repair/replace cable assembly for M239 smoke grenade launcher, right hand side discharger feed through (see WP 0253 00).

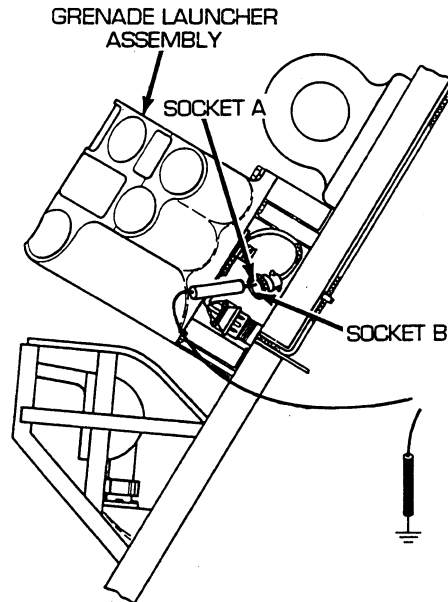
**END OF WORK PACKAGE**

UNIT MAINTENANCE
RECOVERY VEHICLE, FULL TRACKED: MEDIUM, M88A1
NSN 2350-00-122-6826, EIC AQA

HYDRAULIC RESERVOIR MONITORING SYSTEM SWITCHES AND LIGHTS TROUBLESHOOTING PROCEDURE

INITIAL SETUP:

Tools and Special Tools

Tool kit, general mechanic's (item 59, WP 0490 00)

References

WP 0160 00

References (cont.)

WP 0197 00

WP 0237 00

WP 0425 00

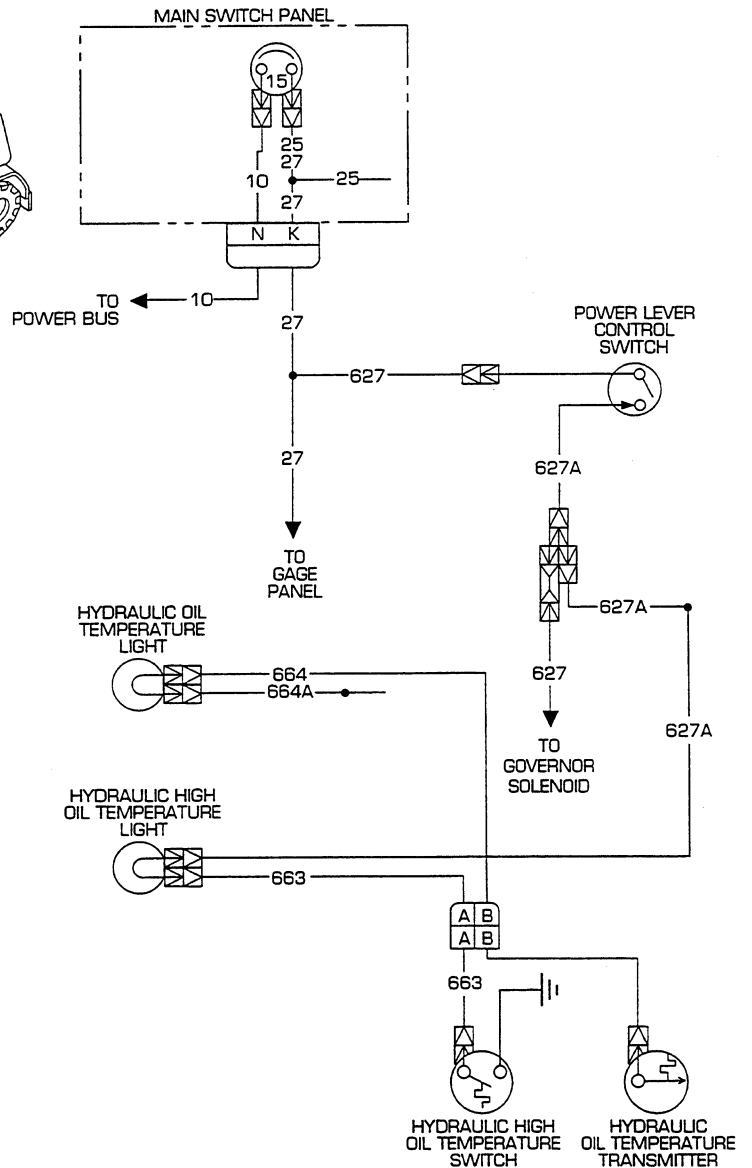
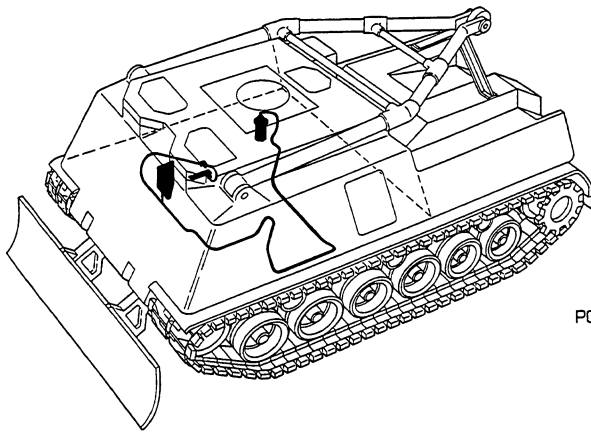

Troubleshooting Procedure

Hydraulic Reservoir Monitoring System Switches and Lights

Symptom

Hydraulic reservoir monitoring system switches or lights malfunctioning.

Malfunction

Hydraulic oil high temperature lamp fails to operate when temperature limit is exceeded. Do steps 1 thru 5.

Hydraulic oil high temperature light fails to go out when temperature is normal. Do steps 3 thru 5.

CORRECTIVE ACTION

WARNING

Remove all jewelry such as rings, dog tags, bracelets, etc. If jewelry contacts a metal surface a direct short may result in instant heating of tools, damage to equipment, and injury or death to personnel.

1. Disconnect flasher system panel wiring harness from hydraulic oil high temperature light. Place red lead of multimeter in socket B of wire 627A and black lead to ground. Turn MASTER switch on, place power control lever switch in ON position, and check for voltage. Turn MASTER switch and power control lever switch OFF. If voltage is present, go to step 3. If voltage is not present, go to step 2.

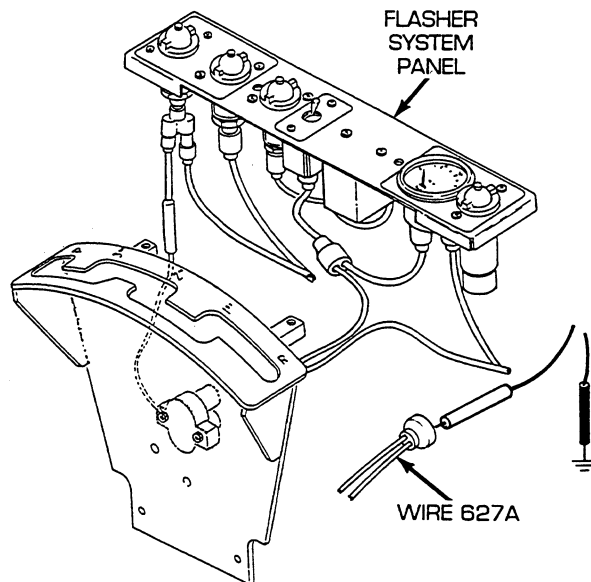

CORRECTIVE ACTION –Continued

2. Reconnect flasher system panel wiring harness to hydraulic oil high temperature light. Disconnect wire 627A of flasher system panel wiring harness from Y-connector at power control lever switch. Place red lead of multimeter on Y-connector terminal and black lead to ground. Turn MASTER switch on, place power control lever switch in ON position, and check for voltage. Turn MASTER switch and power control lever switch OFF. If voltage is present, repair/replace wire 627A of flasher system panel wiring harness from Y-connector to hydraulic high temperature lamp (see WP 0197 00). If voltage is not present, troubleshoot power control lever switch circuit.

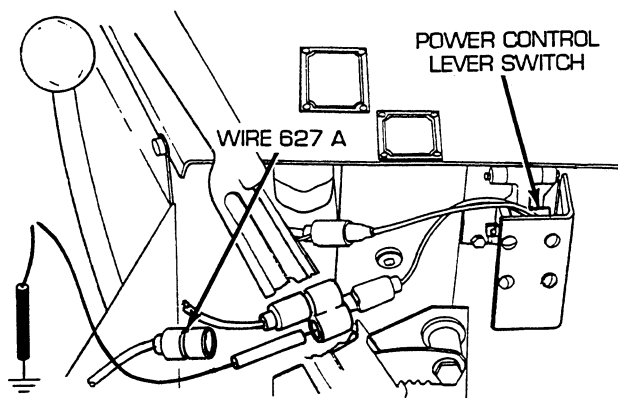

3. Place a jumper wire from socket B to pin B. Place red lead of multimeter on terminal of hydraulic oil high temperature light and black lead to ground. Turn MASTER switch on, place power control lever switch in ON position, and check for voltage. Turn MASTER switch and power control lever switch OFF. If voltage is present, go to step 4. If voltage is not present, replace hydraulic oil high temperature lamp (see WP 0160 00).

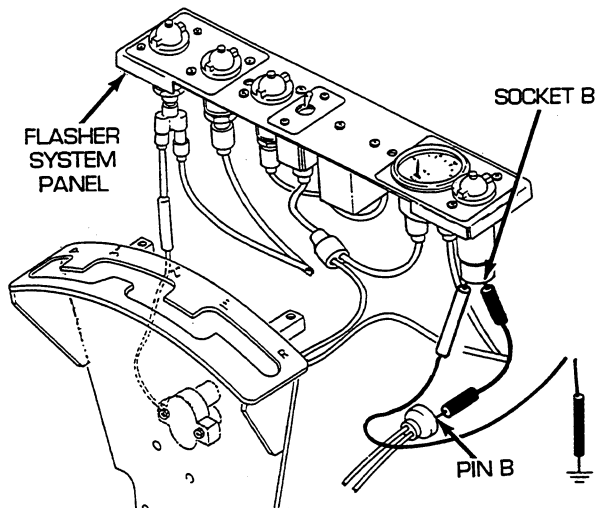

CORRECTIVE ACTION –Continued

4. Reconnect flasher system panel wiring harness to lamp socket. Remove two screws (1), two lock-washers (2), two flat washers (3), and rear intermediate right access floor plate (4). Disconnect flasher system panel wiring harness at hydraulic reservoir disconnect. Place red lead of multimeter in socket A of wire 663 and black lead to ground. Turn MASTER switch on, place power control lever switch in ON position, and check for voltage. Turn MASTER switch and power control lever switch OFF. If voltage is present, go to step E. If voltage is not present, repair/replace wire 663 of flasher system panel wiring harness from hydraulic oil high temperature lamp to hydraulic reservoir disconnect (see WP 0197 00).

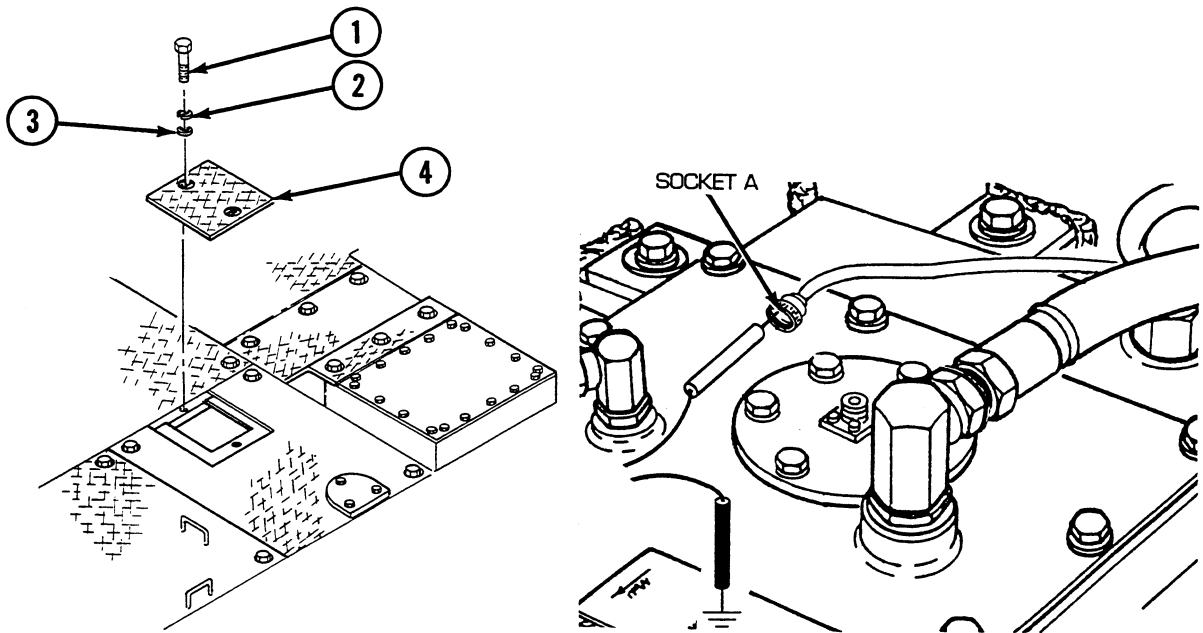

5. Reconnect flasher system panel wiring harness to hydraulic reservoir disconnect. Disconnect wire 663 from high temperature switch on hydraulic reservoir. Place red lead of multimeter in wire 663 and black lead to ground, turn MASTER switch on, place power control lever switch in ON position, and check for voltage. Turn MASTER switch and power control lever switch OFF. If voltage is present, replace high temperature switch (see WP 0425 00). If voltage is not present, repair/replace wire 663 of hydraulic oil temperature transmitter wiring harness (see WP 0237 00).

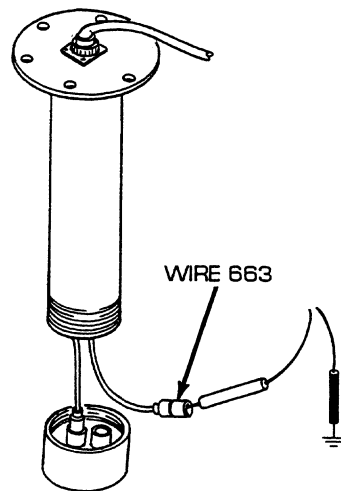

END OF WORK PACKAGE

UNIT MAINTENANCE
RECOVERY VEHICLE, FULL TRACKED: MEDIUM, M88A1
NSN 2350-00-122-6826, EIC AQA
HYDRAULIC RESERVOIR MONITORING SYSTEM GAGE TRANSMITTER
TROUBLESHOOTING PROCEDURE

INITIAL SETUP:**Tools and Special Tools**

Tool kit, general mechanic's (item 59, WP 0490 00)

References

WP 0042 00
WP 0160 00
WP 0197 00

References (cont.)

WP 0202 00
WP 0215 00
WP 0237 00
WP 0425 00
TM 9-2350-256-10

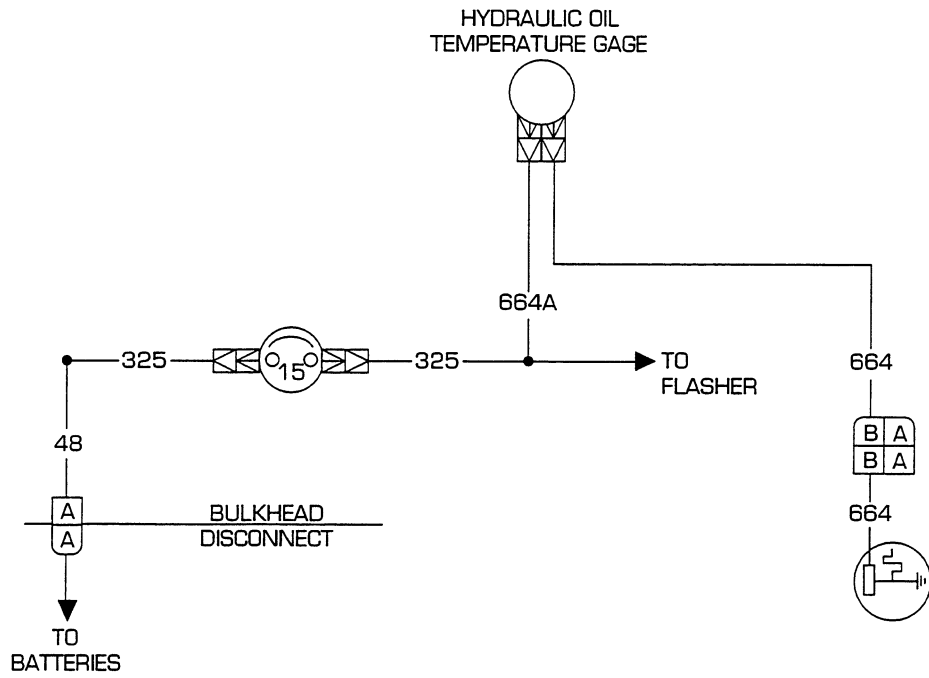
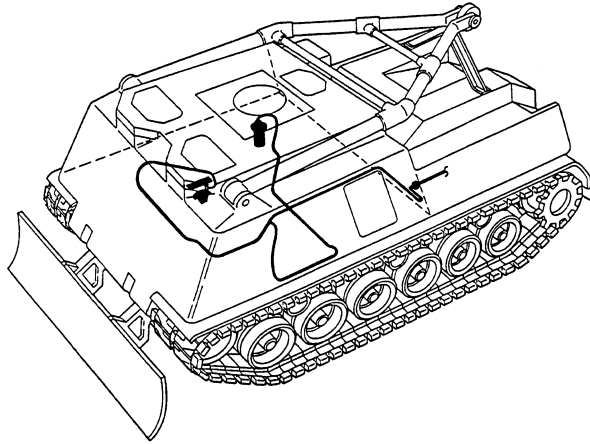

Troubleshooting Procedure**Hydraulic Reservoir Monitoring System Gage Transmitter****Symptom**

Hydraulic reservoir monitoring system gage transmitter malfunctioning.

Malfunction

Hydraulic oil temperature gage fails to operate. Do steps 1 thru 7.

CORRECTIVE ACTION**WARNING**

Remove all jewelry such as rings, dog tags, bracelets, etc. If jewelry contacts a metal surface a direct short may result in instant heating of tools, damage to equipment, and injury or death to personnel.

1. Disconnect wire 664A from hydraulic oil temperature gage. Place red lead of multimeter in wire 664A and black lead to ground. Turn MASTER switch on and check for voltage. Turn MASTER switch OFF. If voltage is present, go to step 4. If voltage is not present, go to step 2.

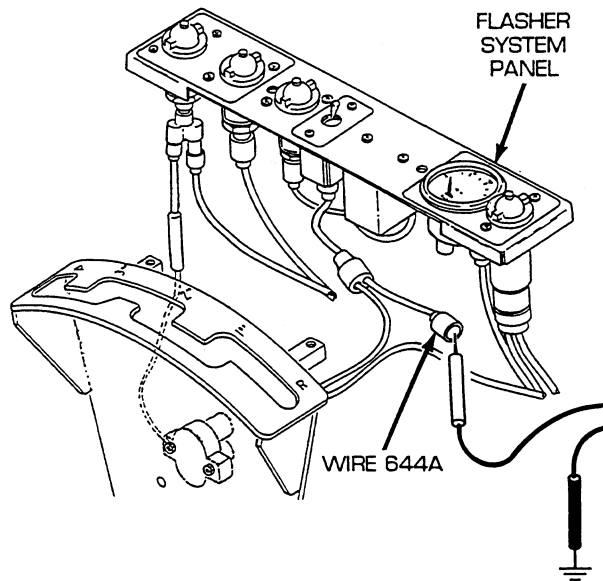

CORRECTIVE ACTION –Continued

2. Reconnect wire 664A to hydraulic oil temperature gage. Disconnect wire 325 from hydraulic oil temperature gage side of 15 A circuit breaker. Place red lead of multimeter on terminal of 15 A circuit breaker and black lead to ground. Turn MASTER switch on and check for voltage. Turn MASTER switch OFF. If voltage is present, repair/replace wire 664A of red flasher breaker to switch wiring harness (see WP 0215 00). If voltage is not present, go to step 3.

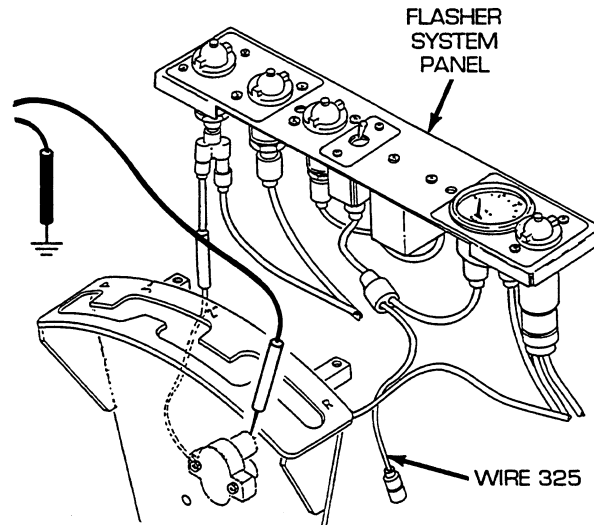

3. Reconnect wire 325 to hydraulic oil temperature gage side of 15 A circuit breaker. Disconnect wire 325 of switch panel, radio, and bilge pump to bulkhead wiring harness from 15 A circuit breaker. Place red lead of multimeter in wire 325 and black lead to ground. Turn MASTER switch on and check for voltage. Turn MASTER switch OFF. If voltage is present, replace 15 A circuit breaker (see WP 0160 00). If voltage is not present, go to step 7.

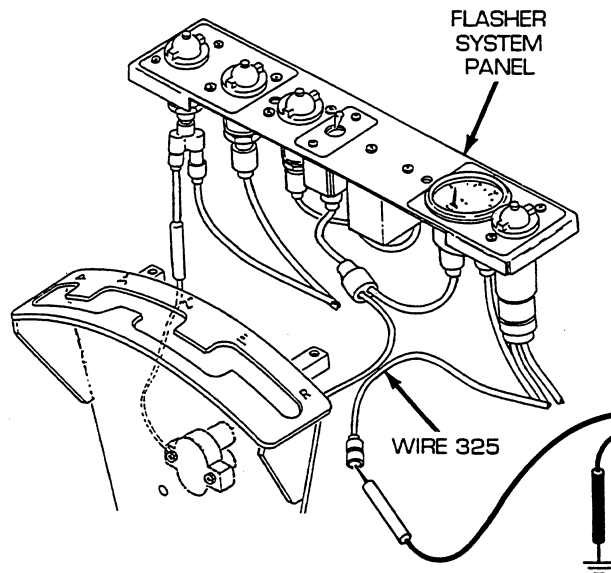

CORRECTIVE ACTION –Continued

4. Reconnect wire 664A to hydraulic oil temperature gage. Disconnect wire 664 from hydraulic oil temperature gage. Place red lead of multimeter on terminal of hydraulic oil temperature gage and black lead to ground. Turn MASTER switch on and check for voltage. Turn MASTER switch OFF. If voltage is present, go to step 5. If voltage is not present, replace hydraulic oil temperature gage (see WP 0160 00).

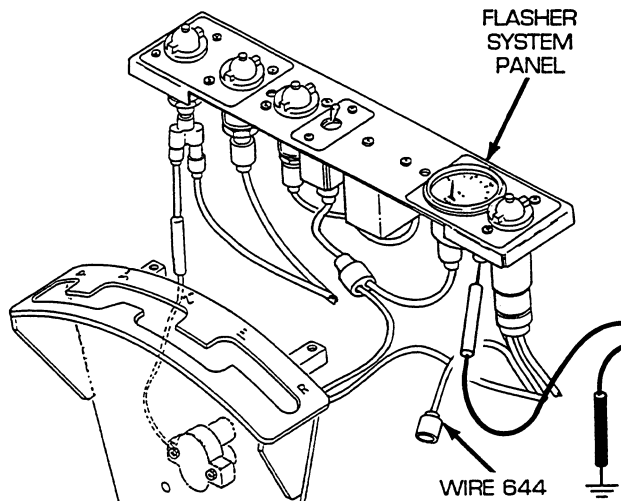

5. Reconnect wire 664 to hydraulic oil temperature gage. Remove two screws (1), two lockwashers (2), two flat washers (3), and rear intermediate right access floor plate (4). Disconnect flasher system panel wiring harness at hydraulic reservoir disconnect. Place red lead of multimeter in socket B of wire 664 and black lead to ground. Turn MASTER switch on and check for voltage. Turn MASTER switch OFF. If voltage is present, go to step 6. If voltage is not present, repair/replace wire 664 of flasher system panel wiring harness (see WP 0197 00).

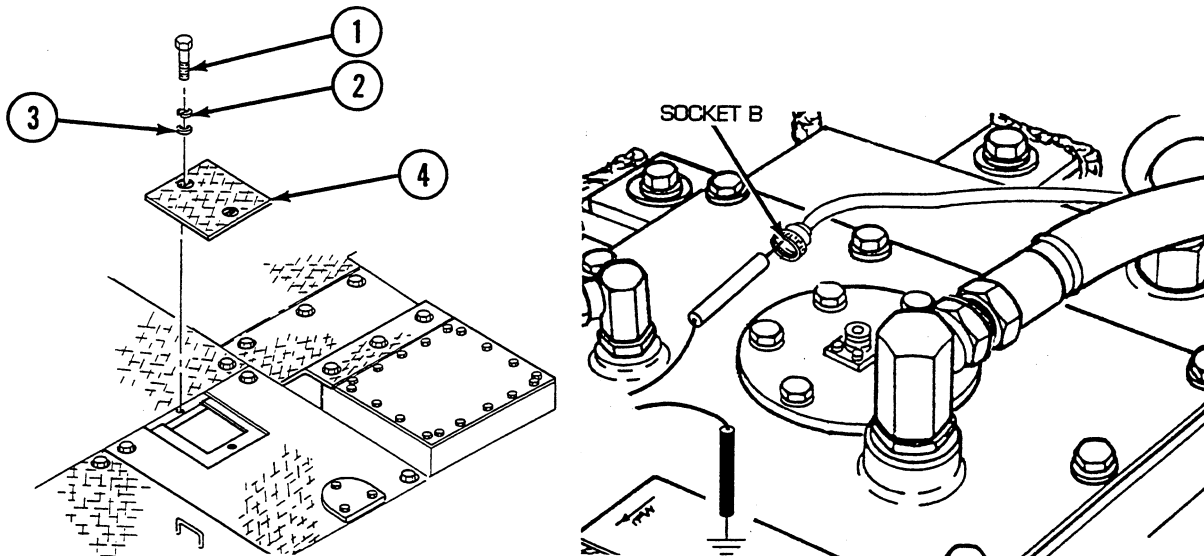

CORRECTIVE ACTION –Continued

6. Reconnect flasher system panel wiring harness to hydraulic reservoir disconnect. Disconnect wire 664 from hydraulic oil temperature transmitter (see WP 0425 00). Place red lead of multimeter in wire 664 and black lead to ground. Turn MASTER switch on and check for voltage. Turn MASTER switch OFF. If voltage is present, replace hydraulic oil temperature transmitter (see WP 0425 00). If voltage is not present, repair/replace wire 664 from hydraulic reservoir disconnect to hydraulic oil temperature transmitter (see WP 0237 00).

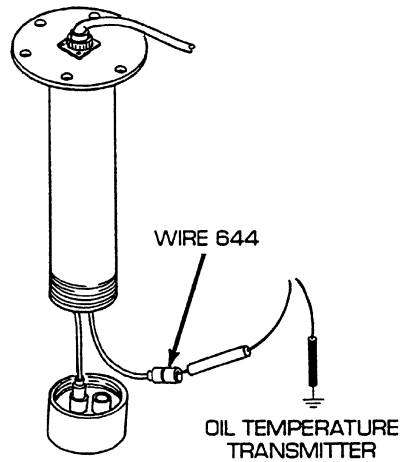

7. Reconnect wire 325 of switch panel, radio, and bilge pump to bulkhead wiring harness from 15 A circuit breaker. Open air inlet doors (TM 9-2350-256-10). Disconnect wire 48 pin A from bulkhead to master relay wiring harness. Place red multimeter lead in socket and black lead to ground. Turn MASTER switch on and check for voltage. Turn MASTER switch OFF. If voltage is present, repair/replace switch panel, radio, and bilge pump to bulkhead wiring harness (see WP 0202 00). If voltage is not present, troubleshoot master relay circuit (see WP 0042 00).

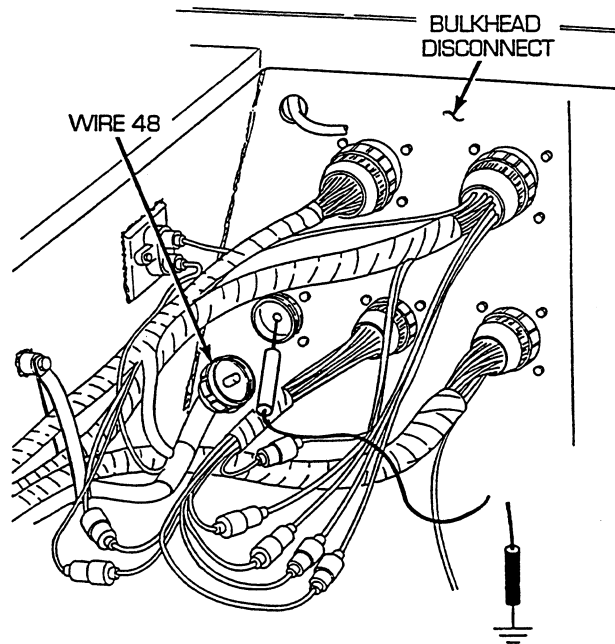
**END OF WORK PACKAGE**

UNIT MAINTENANCE
RECOVERY VEHICLE, FULL TRACKED: MEDIUM, M88A1
NSN 2350-00-122-6826, EIC AQA
EXHAUST SMOKE GENERATING SYSTEM TROUBLESHOOTING PROCEDURE

INITIAL SETUP:**Tools and Special Tools**

Tool kit, general mechanic's (item 59, WP 0490 00)

References

WP 0042 00
WP 0098 00
WP 0150 00
WP 0159 00
WP 0202 00
WP 0204 00
WP 0205 00
WP 0207 00
WP 0208 00
WP 0218 00
WP 0222 00

References (cont.)

WP 0223 00
WP 0224 00
WP 0225 00
WP 0228 00
WP 0229 00
WP 0242 00
WP 0243 00
WP 0244 00
WP 0246 00
WP 0336 00
WP 0445 00
WP 0448 00
WP 0449 00
TM 9-2350-256-10

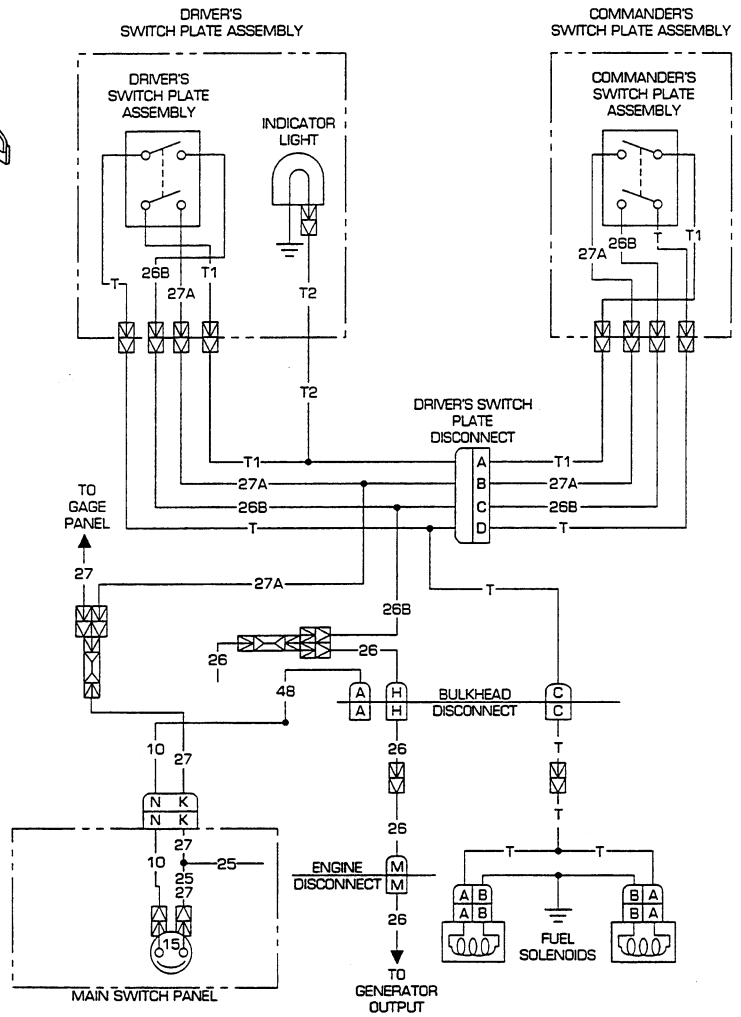
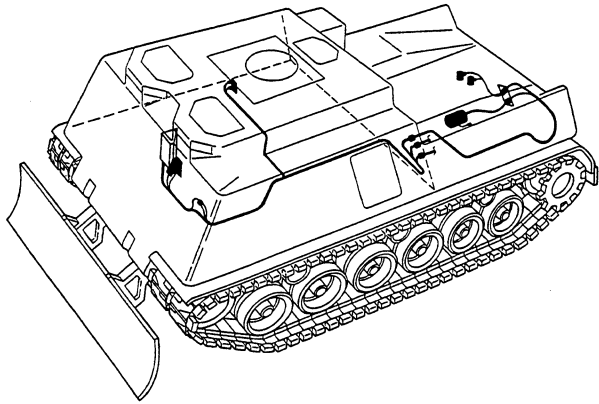

Troubleshooting Procedure

Exhaust Smoke Generating System

Symptom

Exhaust smoke generating system malfunctioning.

Malfunction

Vehicle generates smoke but indicator light fails to operate. Do steps 1 thru 4.

Vehicle does not generate smoke. Do steps 1 thru 25.

Commander's switch fails to operate. Do steps 22 thru 24.

CORRECTIVE ACTION**WARNING**

Remove all jewelry such as rings, dog tags, bracelets, etc. If jewelry contacts a metal surface a direct short may result in instant heating of tools, damage to equipment, and injury or death to personnel.

1. Remove lamp from socket. Place red lead of multimeter in socket and black lead to ground. Turn MASTER and driver's VEHICLE EXHAUST SMOKE switches ON and check for voltage. Turn MASTER and driver's VEHICLE EXHAUST SMOKE switches OFF. If voltage is present, replace lamp (see WP 0448 00). If voltage is not present, go to step 2.

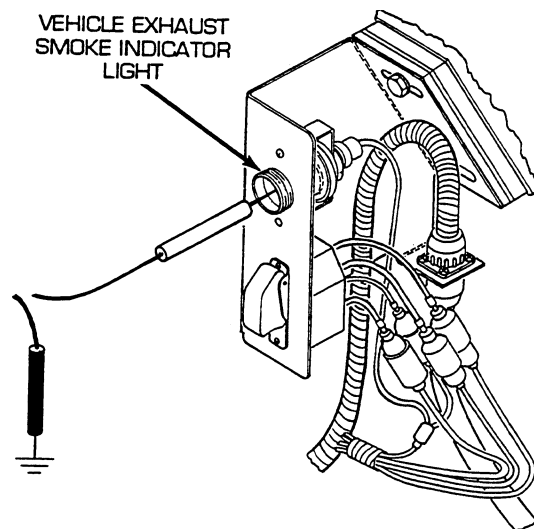

CORRECTIVE ACTION –Continued

2. Reinstall lamp to socket. Disconnect wire T2 from indicator light. Place red lead of multimeter on wire T2 and black lead to ground. Turn MASTER and driver's VEHICLE EXHAUST SMOKE switches ON and check for voltage. Turn MASTER and driver's VEHICLE EXHAUST SMOKE switches OFF. If voltage is present, replace lamp socket (see WP 0448 00). If voltage is not present, go to step 3.

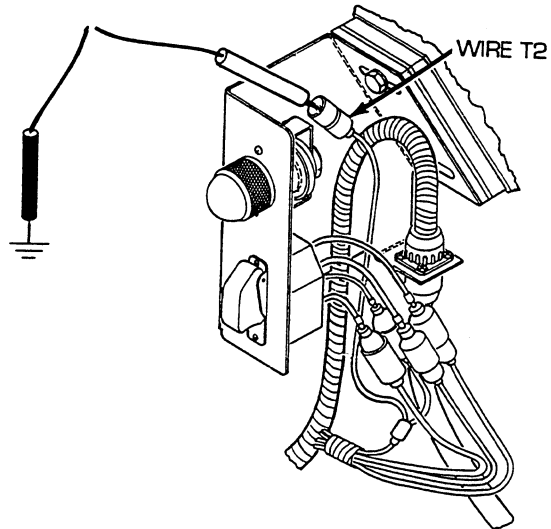

3. Reconnect wire T2 to indicator light. Disconnect driver's vehicle exhaust smoke bracket to bulkhead connection wiring harness from driver's switch plate disconnect behind switch panel. Place red lead of multimeter in socket B of wire 27A and black lead to ground. Turn MASTER switch on and check for voltage. Turn MASTER switch OFF. If voltage is present, go to step 10. If voltage is not present, go to step 4.

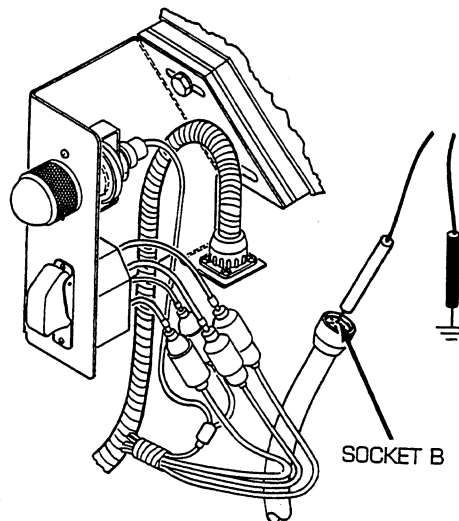

CORRECTIVE ACTION –Continued

4. Reconnect driver’s vehicle exhaust smoke bracket to bulkhead connection wiring harness to driver’s switch plate disconnect. Remove three screws (1), three lockwashers (2), ground lead (3), and flat washer (4) and release main switch panel (5) from mounting brackets. Disconnect switch panel to gage panel and miscellaneous switches wiring harness from main switch panel. Place a jumper wire from pin N to socket N. Place red lead of multimeter in socket K of wire 27 and black lead to ground. Turn MASTER switch on and check for voltage. Turn MASTER switch OFF. If voltage is present, go to step 8. If voltage is not present, go to step 5.

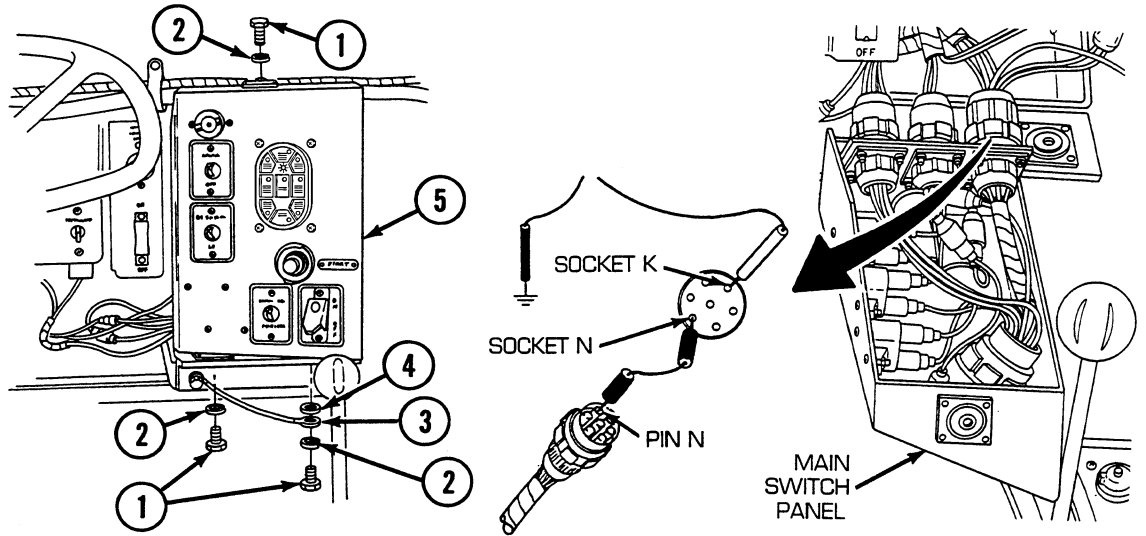

5. Place red lead of multimeter in pin N of wire 10 and black lead to ground. Turn MASTER switch on and check for voltage. Turn MASTER switch OFF. If voltage is present, go to step 6. If voltage is not present, go to step 25.

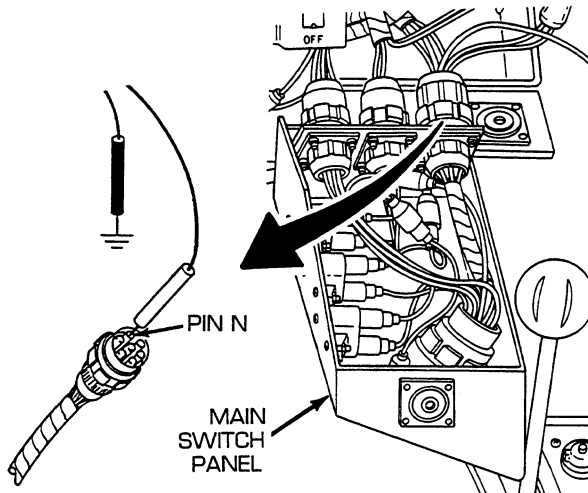

CORRECTIVE ACTION –Continued

6. Reconnect switch panel to gage panel and miscellaneous switches wiring harness to main switch panel. Place a jumper wire from switch panel to hull to ground panel. Disconnect wire 25/27 from 15 A circuit breaker. Place red lead of multimeter on circuit breaker terminal and black lead to ground. Turn MASTER switch on and check for voltage. Turn MASTER switch OFF. If voltage is present, repair/replace wire 25/27 of main lighting and B.O. selector switch wiring harness (see WP 0218 00). If voltage is not present, go to step 7.

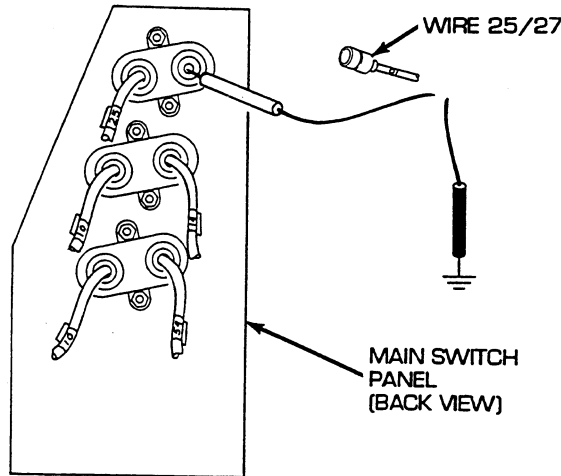

7. Reconnect wire 25/27 to 15 A circuit breaker. Disconnect wire 10 from 15 A circuit breaker. Place red lead of multimeter on wire 10 and black lead to ground. Turn MASTER switch on and check for voltage. Turn MASTER switch OFF. If voltage is present, replace 15 A circuit breaker (see WP 0159 00). If voltage is not present, repair/replace wire 10 of main lighting and B.O. selector switch wiring harness (see WP 0218 00).

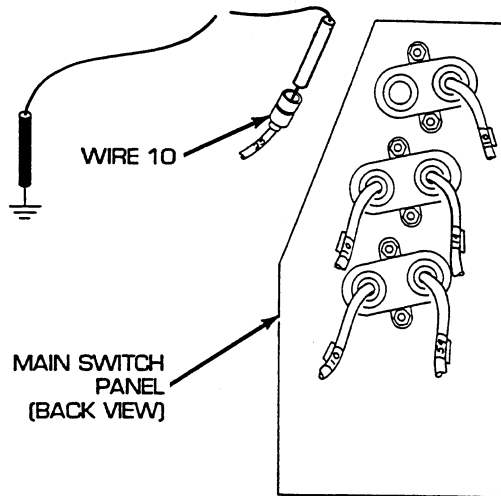

CORRECTIVE ACTION –Continued

8. Reconnect wire 27A to driver's VEHICLE EXHAUST SMOKE switch. Disconnect wire 27A of driver's vehicle exhaust smoke bracket to bulkhead connection wiring harness at Y-connector. Place red lead of multimeter on male connector and black lead to ground. Turn MASTER switch on and check for voltage. Turn MASTER switch OFF. If voltage is present, repair/replace wire 27A of driver's vehicle exhaust smoke bracket to bulkhead connection wiring harness from driver's switch to Y-connector (see WP 0242 00). If voltage is not present, go to step 9.

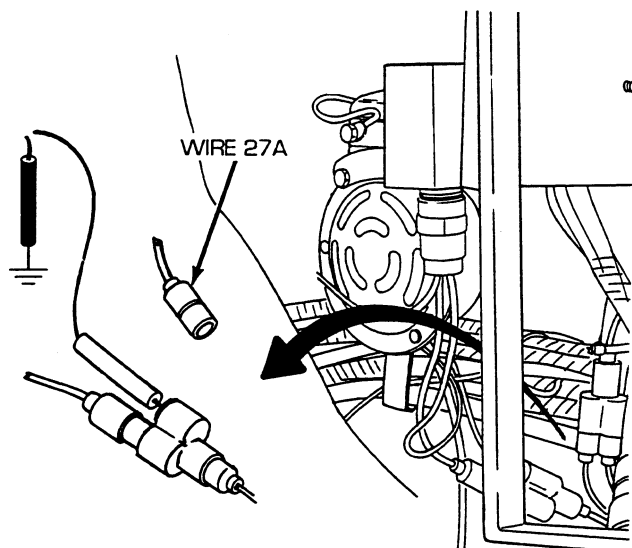

9. Reconnect wire 27A of driver's vehicle exhaust smoke bracket to bulkhead connection wiring harness to Y-connector. Disconnect wire 27 of switch panel to gage panel and miscellaneous switches wiring harness from Y-connector. Place red lead of multimeter on wire 27 and black lead to ground. Turn MASTER switch on and check for voltage. Turn MASTER switch OFF. If voltage is present, replace Y-connector (see WP 0242 00). If voltage is not present, repair/replace wire 27 of switch panel to gage panel and miscellaneous switches wiring harness (see WP 0204 00 for dual voltage; 0205 00 for single voltage).

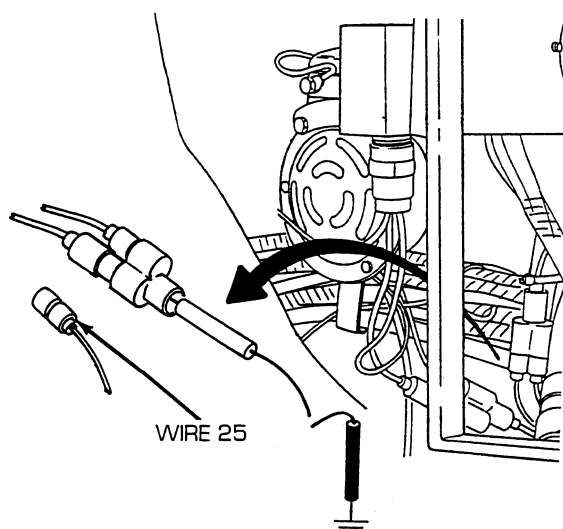

CORRECTIVE ACTION –Continued

10. Place red lead of multimeter in socket C of wire 26B and black to ground. Turn MASTER switch on and check for voltage. Turn MASTER switch OFF. If voltage is not present, go to step 17. If voltage is present, go to step 11.

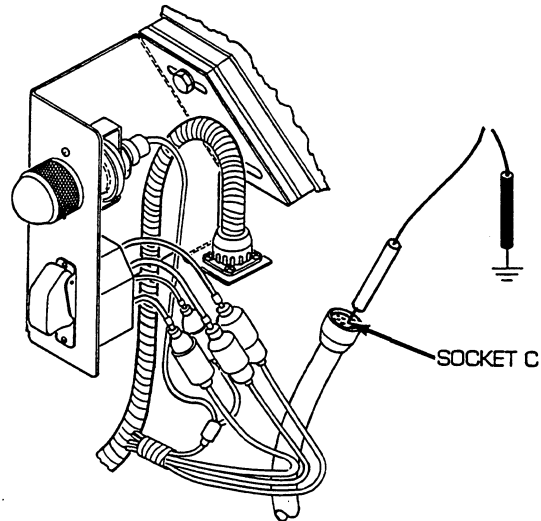

11. Place red lead of multimeter in socket D of wire T and black lead to ground. Turn MASTER switch on and check for voltage. Turn MASTER switch OFF. If voltage is present, go to step 12. If voltage is not present, go to step 15.

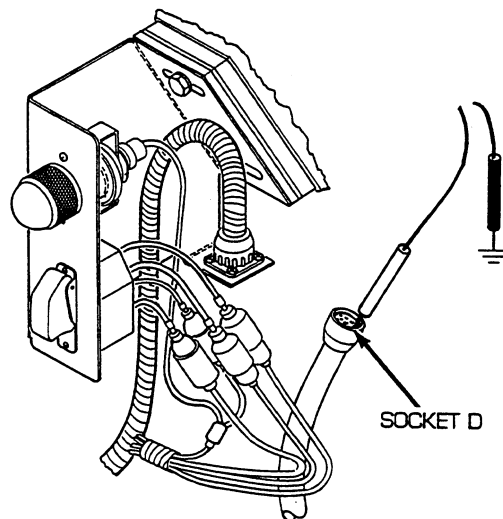

CORRECTIVE ACTION –Continued

12. Reconnect driver's vehicle exhaust smoke bracket to bulkhead connection wiring harness to driver's switch plate disconnect. Open air inlet doors (TM 9-2350-256-10). Disconnect bulkhead to engine bracket and rear fuel tank transmitter wiring harness from bulkhead disconnect. Place red lead of multimeter in socket C of wire T and black lead to ground. Turn MASTER and driver's VEHICLE EXHAUST SMOKE switches ON and check for voltage. Turn MASTER and driver's VEHICLE EXHAUST SMOKE switches OFF. If voltage is present, go to step 13. If voltage is not present, repair/replace wire T of driver's vehicle exhaust smoke bracket to bulkhead connection wiring harness (see WP 0242 00).

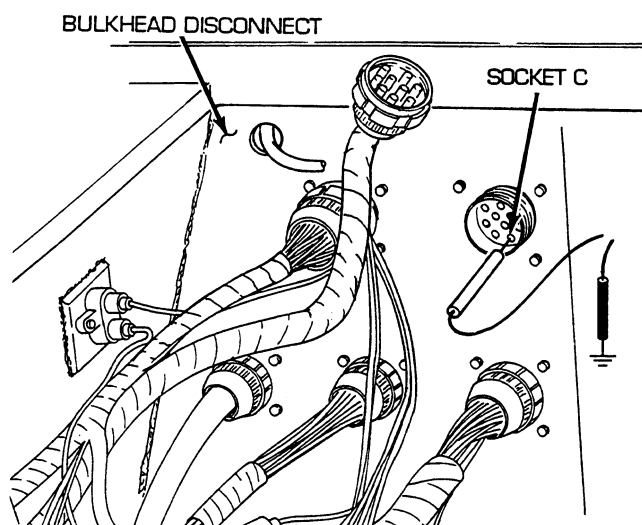

13. Reconnect bulkhead to engine bracket and rear fuel tank transmitter wiring harness to bulkhead. Remove engine deck (see WP 0336 00). Disconnect smoke generating system lead assembly from engine connector. Place red lead of multimeter on wire T and black lead to ground. Turn MASTER and driver's VEHICLE EXHAUST SMOKE switches ON and check for voltage. Turn MASTER and VEHICLE EXHAUST SMOKE switches OFF. If voltage is present, got to step 14. If voltage is not present, repair/replace wire T of exhaust smoke generating system lead assembly (see WP 0246 00).

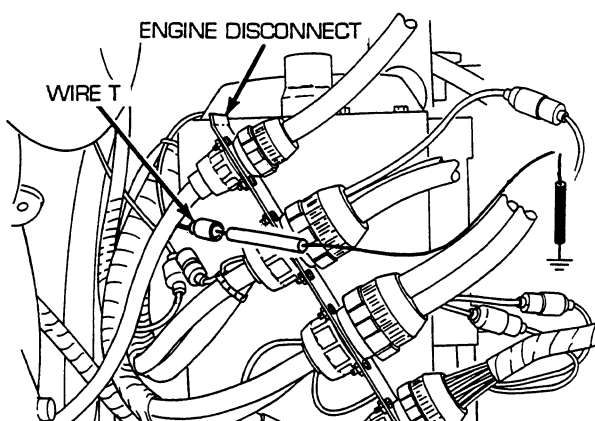

CORRECTIVE ACTION –Continued

14. Reconnect smoke generating system lead assembly to engine connector. Disconnect fuel solenoid wiring harness from two fuel solenoids. Place red lead of multimeter in wire T of first fuel solenoid and black lead to ground. Turn MASTER and driver's VEHICLE EXHAUST SMOKE switches ON and check for voltage. Place red lead of multimeter in wire T of second fuel solenoid and check for voltage. If voltage is present, replace fuel solenoid (see WP 0445 00). If voltage is not present, repair/replace wire T of fuel solenoid wiring harness (see WP 0244 00).

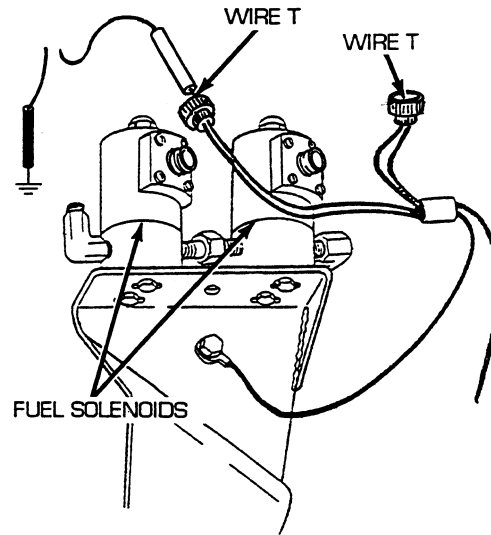

15. Reconnect driver's vehicle exhaust smoke bracket to bulkhead connection wiring harness to driver's switch plate disconnect. Disconnect wire 26B from driver's VEHICLE EXHAUST SMOKE switch. Place red lead of multimeter on wire 26B and black lead to ground. Turn MASTER switch on and check for voltage. Turn MASTER switch OFF. If voltage is present, go to step 16. If voltage is not present, repair/replace wire 26B of driver's exhaust smoke bracket to bulkhead connection wiring harness (see WP 0242 00).

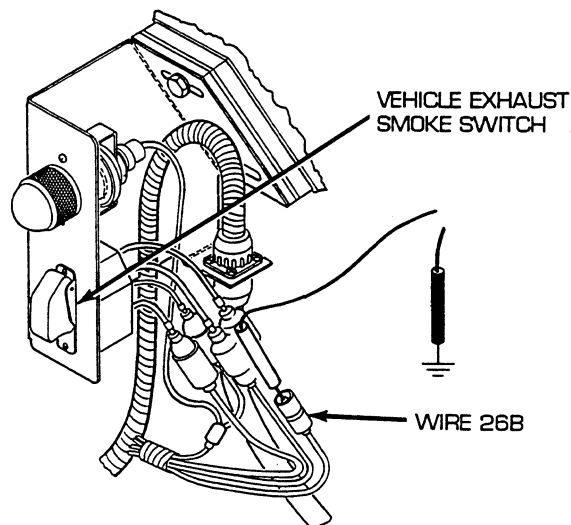

CORRECTIVE ACTION –Continued

16. Reconnect wire 26B to driver's VEHICLE EXHAUST SMOKE switch. Disconnect wire T from driver's VEHICLE EXHAUST SMOKE switch. Place red lead of multimeter on wire T and black lead to ground. Turn MASTER and driver's VEHICLE EXHAUST SMOKE switches ON and check for voltage. Turn MASTER and driver's VEHICLE EXHAUST SMOKE switches OFF. If voltage is present, repair/replace wire T of driver's vehicle exhaust smoke bracket to bulkhead connection wiring harness (see WP 0242 00). If voltage is not present, replace driver's VEHICLE EXHAUST SMOKE switch (see WP 0448 00).

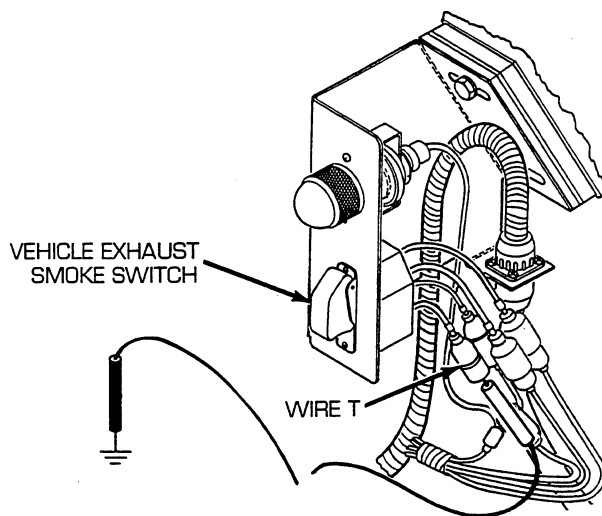

17. Reconnect driver's vehicle exhaust smoke bracket to bulkhead connection wiring harness to driver's switch plate disconnect. Disconnect wire 26B from Y-connector behind gage panel. Place red lead of multimeter on connector and black lead to ground. Turn MASTER switch on and check for voltage. Turn MASTER switch OFF. If voltage is present, repair/replace wire 26B of driver's vehicle exhaust smoke bracket to bulkhead connection wiring harness (see WP 0242 00). If voltage is not present, go to step 18.

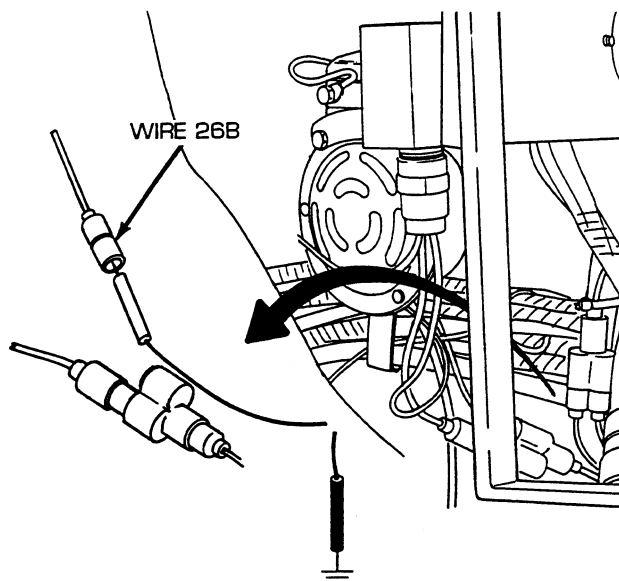

CORRECTIVE ACTION –Continued

18. Reconnect wire 26B to Y-connector behind gage panel. Open air inlet doors. Disconnect bulkhead to APU, master relay and rigger's lights wiring harness from bulkhead disconnect. Place red lead of multimeter in socket H of wire 26 and black lead to ground. Turn MASTER switch on and check for voltage. Turn MASTER switch OFF. If voltage is present, repair/replace wire 26 of APU control box to foot dimmer switch and bulkhead wiring harness (see WP 0228 00 for dual voltage; 0229 00 for single voltage). If voltage is not present, go to step 19.

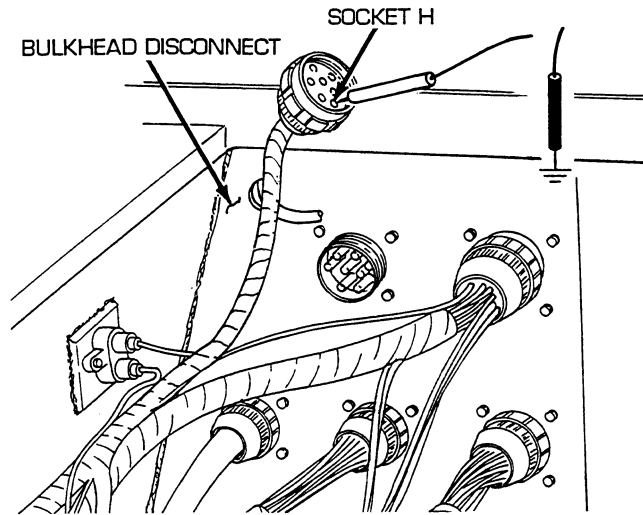

19. Reconnect bulkhead to APU, master relay, and rigger's lights wiring harness to bulkhead. Remove engine deck (see WP 0336 00). Disconnect wire 26 of bulkhead to APU, master relay and rigger's lights wiring harness from connector. Place red lead of multimeter in wire 26 and black lead to ground. Turn MASTER switch on and check for voltage. Turn MASTER switch OFF. If voltage is present, repair/replace wire 26 of bulkhead to APU, master relay, and rigger's lights wiring harness (see WP 0224 00 for dual voltage; 0225 00 for single voltage). If voltage is not present, go to step 20.

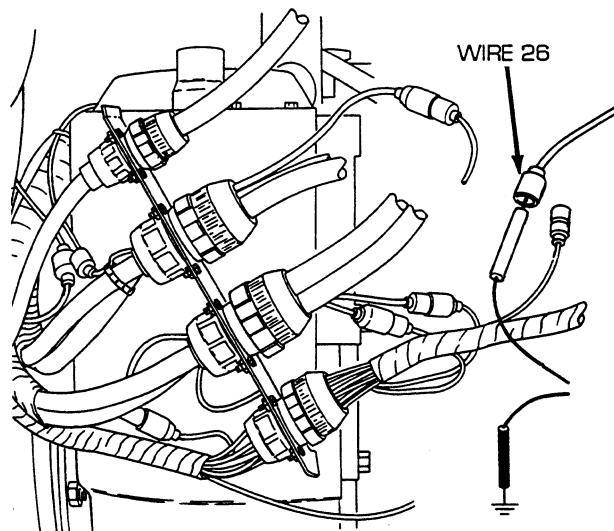

CORRECTIVE ACTION –Continued

20. Reconnect wire 26 of bulkhead to APU, master relay, and rigger's lights wiring harness to connector. Disconnect bulkhead to engine bracket and rear fuel tank transmitter wiring harness from engine disconnect. Place red lead of multimeter on pin M of wire 26 and black lead to ground. Turn MASTER switch on and check for voltage. Turn MASTER switch OFF. If voltage is present repair/replace wire 26 of bulkhead to engine bracket and rear fuel tank transmitter wiring harness (see WP 0222 00 for dual voltage; 0223 00 for single voltage). If voltage is not present, go to step 21.

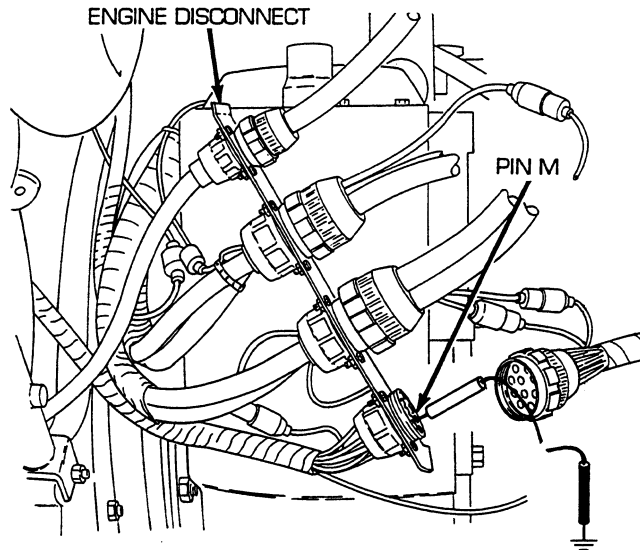

21. Remove powerplant (see WP 0098 00). Disconnect wire 26 at generator terminal. Place red lead of multimeter on wire 26 and black lead on pin M of wire 26. Check for continuity. If continuity is present, replace main generator (see WP 0150 00). If continuity is not present, repair/replace wire 26 of engine wiring harness (see WP 0207 00 for dual voltage; 0208 00 for single voltage).

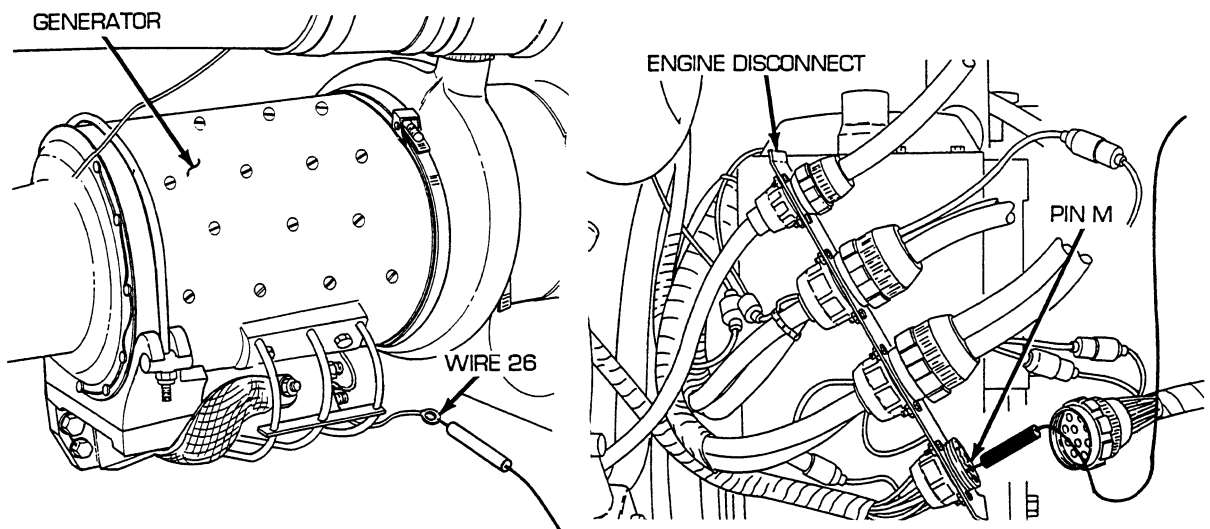

CORRECTIVE ACTION –Continued

22. Disconnect driver's vehicle exhaust smoke bracket to bulkhead wiring harness from driver's switch plate disconnect. Place red lead of multimeter on pin C of wire 26B and black lead on pin D of wire T. Turn commander's VEHICLE EXHAUST SMOKE switch ON and check for continuity. Turn commander's VEHICLE EXHAUST SMOKE switch OFF. If continuity is present, go to step 16. If continuity is not present, go to step 23.

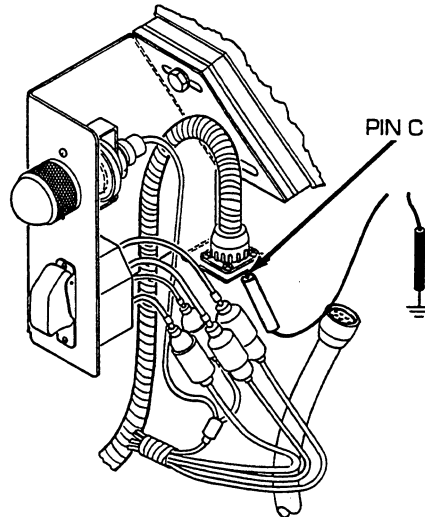

23. Reconnect driver's vehicle exhaust smoke bracket to bulkhead connect wiring harness to driver's switch plate disconnect. Disconnect wire 26B at commander's VEHICLE EXHAUST SMOKE switch. Place red lead of multimeter on wire 26B and black lead to ground. Turn MASTER switch on and check for voltage. Turn MASTER switch OFF. If voltage is present, go to step 24. If voltage is not present repair/replace wire 26B of commander's switch plate to driver's vehicle exhaust smoke bracket wiring harness (see WP 0243 00).
24. Reconnect wire 26B to commander's VEHICLE EXHAUST SMOKE switch. Disconnect wire T from commander's VEHICLE EXHAUST SMOKE switch. Place red lead of multimeter on wire T and black lead to ground. Turn MASTER and commander's VEHICLE EXHAUST SMOKE switches ON and check for voltage. Turn MASTER and commander's VEHICLE EXHAUST SMOKE switches OFF. If voltage is present, repair/replace wire T of commander's switch plate to driver's vehicle exhaust smoke bracket wiring harness (see WP 0243 00). If voltage is not present, replace commander's VEHICLE EXHAUST SMOKE switch (see WP 0449 00).

CORRECTIVE ACTION –Continued

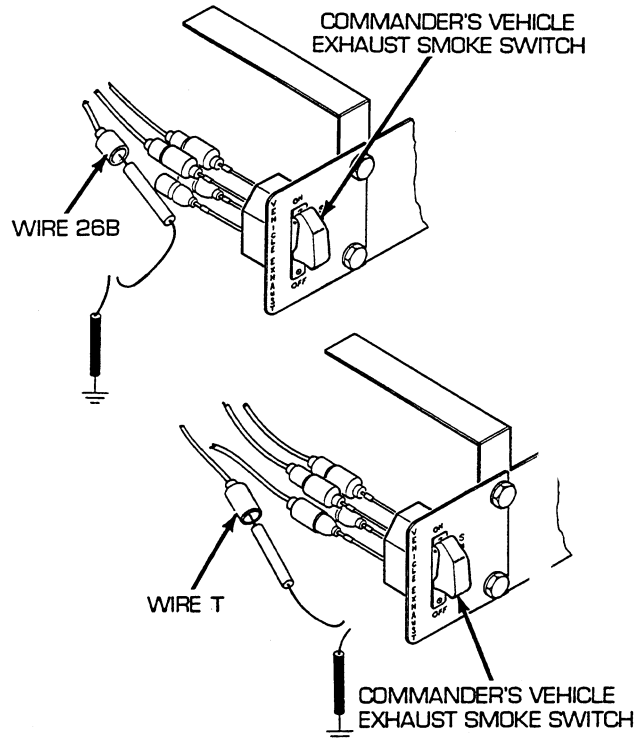

25. Reconnect switch panel to gage panel and miscellaneous switches wiring harness to main switch panel. Install main switch panel (5), flat washer (4), ground lead (3), three lockwashers (2), and three screws (1) to mounting bracket. Open air inlet door. Disconnect wire 48 pin A from bulkhead to master relay wiring harness. Place red multimeter lead in socket and black lead to ground. Turn MASTER switch on and check for voltage. Turn MASTER switch OFF. If voltage is present, repair/replace switch panel, radio, and bilge pump to bulkhead wiring harness (see WP 0202 00). If voltage is not present, troubleshoot master relay circuit (see WP 0042 00).

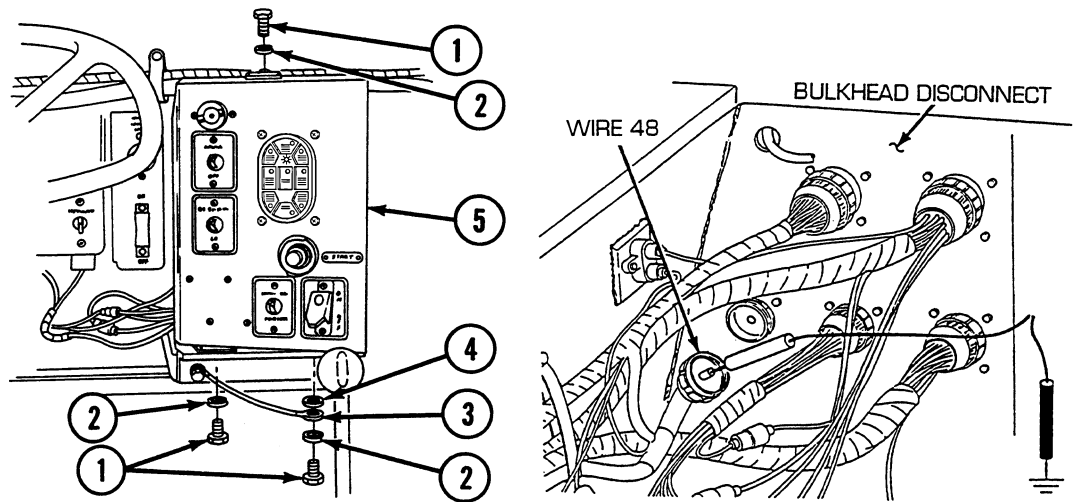

END OF WORK PACKAGE

UNIT MAINTENANCE
RECOVERY VEHICLE, FULL TRACKED: MEDIUM, M88A1
NSN 2350-00-122-6826, EIC AQA

FUEL/WATER SEPARATOR CONTROL MODULE SYSTEM TROUBLESHOOTING PROCEDURE

INITIAL SETUP:**Tools and Special Tools**

Tool kit, general mechanic's (item 59, WP 0490 00)

References

WP 0098 00
WP 0099 00
WP 0130 00
WP 0189 00
WP 0190 00

References (cont.)

WP 0191 00
WP 0207 00
WP 0208 00
WP 0222 00
WP 0223 00
WP 0245 00
WP 0336 00
TM 9-2350-256-10

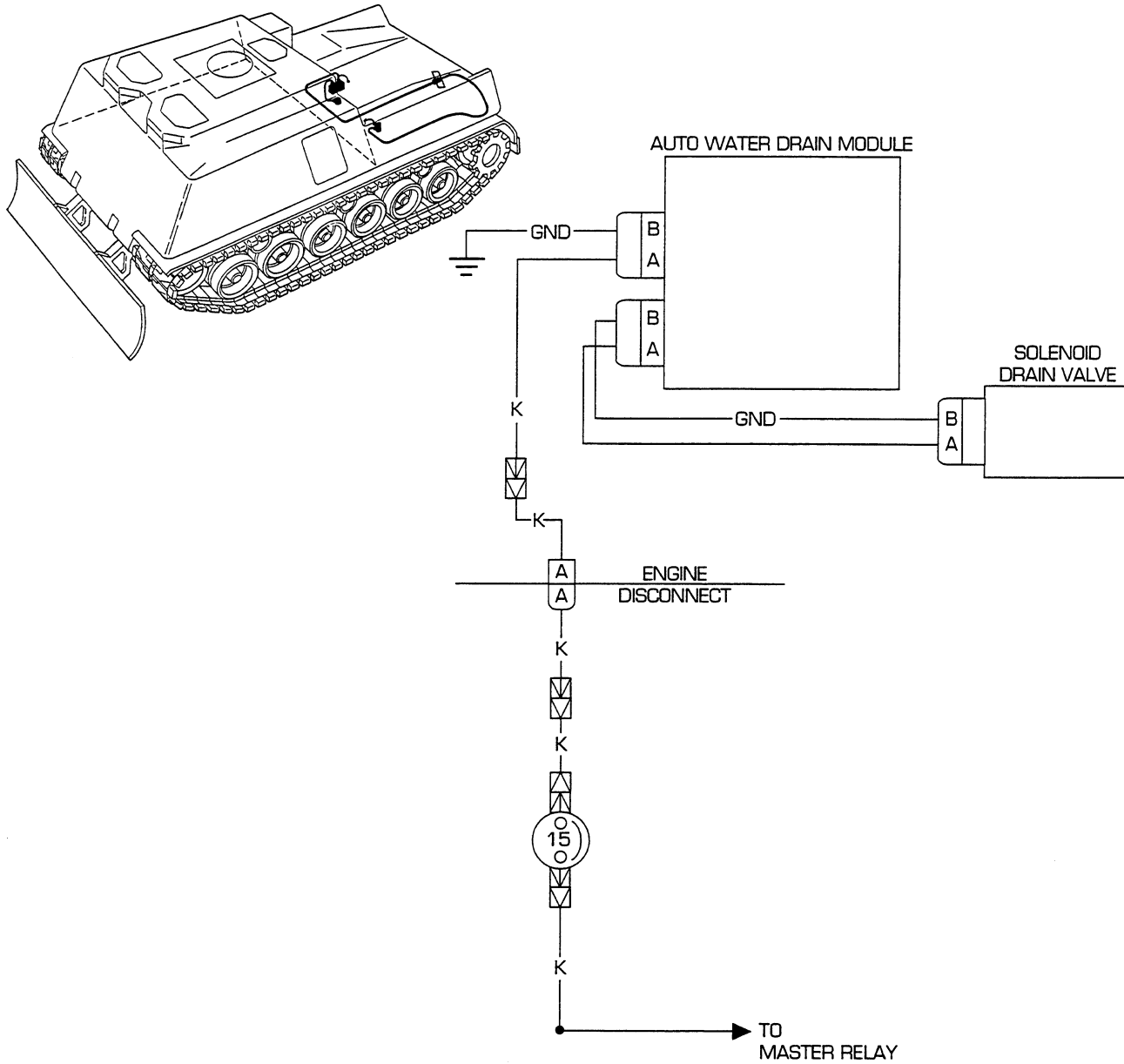

Troubleshooting Procedure

Fuel/Water Separator Control Module System

Symptom

Fuel/water separator control module system malfunctioning.

Malfunction

Automatic water drain system fails to operate. Do steps 1 thru 9.

CORRECTIVE ACTION**WARNING**

Remove all jewelry such as rings, dog tags, bracelets, etc. If jewelry contacts a metal surface a direct short may result in instant heating of tools, damage to equipment, and injury or death to personnel.

1. Remove powerplant and groundhop (see WP 0098 00 and 0099 00). Disconnect engine wiring harness connector from control module. Place red lead of multimeter in socket A of wire K and black lead to ground. Turn MASTER switch on and check for voltage. Turn MASTER switch OFF. If voltage is present, go to step 2. If voltage is not present, go to step 5.

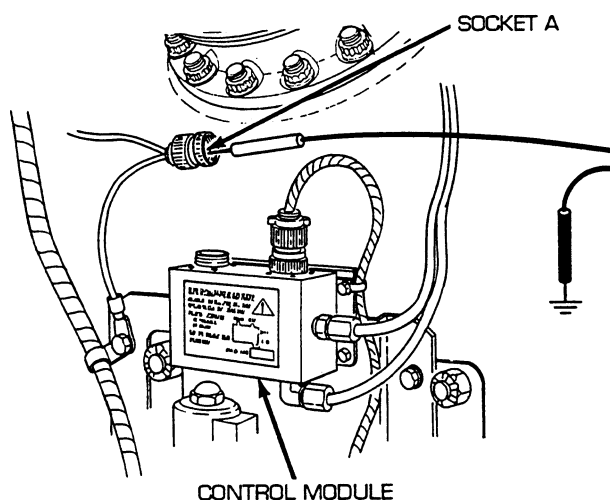

2. Place red lead of multimeter in socket B and black lead to ground. If continuity is present, go to step 3. If continuity is not present, repair/replace GND wire of engine wiring harness (see WP 0207 00 for dual voltage; 0208 00 for single voltage).

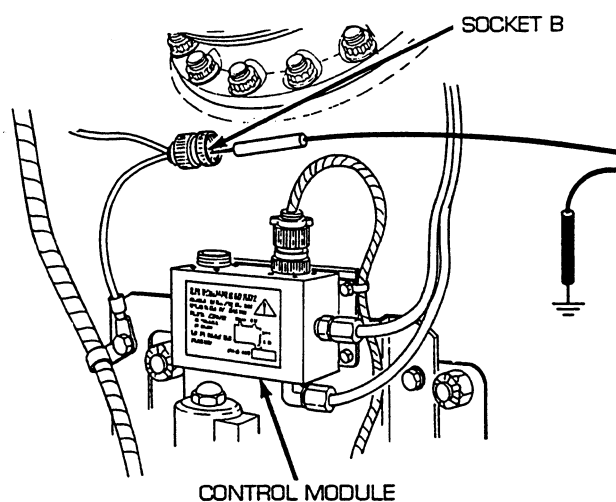

CORRECTIVE ACTION –Continued

3. Reconnect engine wiring harness connector to control module. Disconnect fuel/water separator control module to solenoid drain valve wiring harness from control module. Place red lead of multimeter on pin A of control module and black lead to ground. Turn MASTER switch on and check for voltage. Turn MASTER switch OFF. If voltage is present, go to step 4. If voltage is not present, replace fuel/water separator control module (see WP 0130 00).

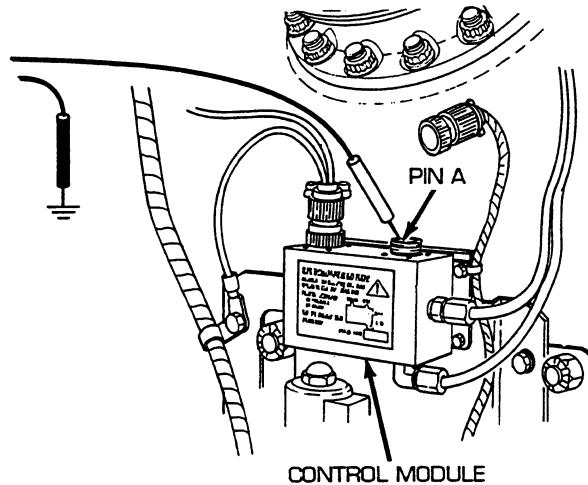

4. Reconnect fuel/water separator control module to solenoid drain valve wiring harness to control module and disconnect from solenoid drain valve. Place red lead of multimeter in socket A of wiring harness and black lead to ground. Turn MASTER switch on and check for voltage. Turn MASTER switch OFF. If voltage is present, replace solenoid drain valve (see WP 0130 00). If voltage is not present, repair/replace fuel/water separator control module to solenoid drain valve wiring harness (see WP 0245 00).

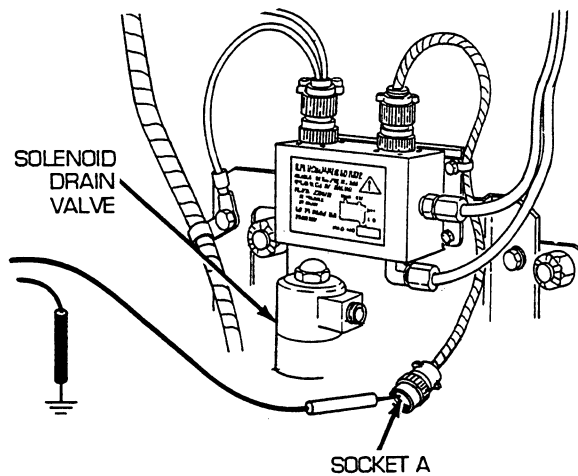

CORRECTIVE ACTION –Continued

5. Reconnect engine wiring harness connector to auto water drain module. Open air inlet doors (TM 9-2350-256-10). Disconnect wire K of bulkhead to APU master relay and rigger's lights wiring harness from bulkhead side of 15 A circuit breaker in battery compartment. Place red lead of multimeter in female connector of wire K and black lead to ground. Turn MASTER switch on and check for voltage. Turn MASTER switch OFF. If voltage is present, go to step 6. If voltage is not present, troubleshoot battery circuit.

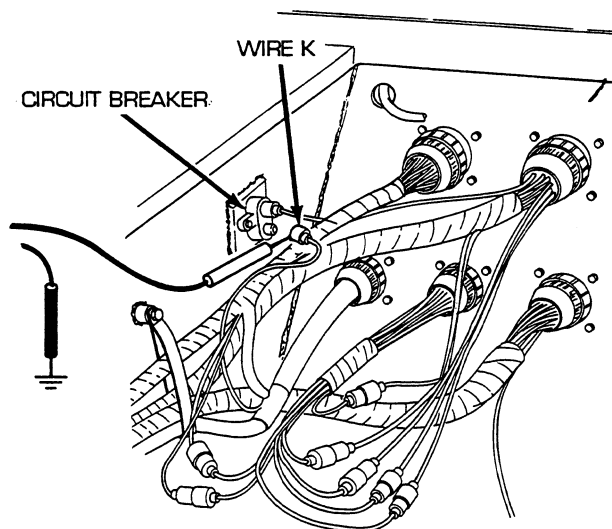

6. Reconnect wire K of bulkhead to APU master relay and rigger's lights wiring harness to bulkhead connector side of 15 A circuit breaker. Disconnect wire K of bulkhead to engine bracket and rear fuel tank transmitter wiring harness from other side of 15 A circuit breaker. Place red lead of multimeter on circuit breaker terminal and black lead to ground. Turn MASTER switch on and check for voltage. Turn MASTER switch OFF. If voltage is present, go to step 7. If voltage is not present, replace 15 A circuit breaker.

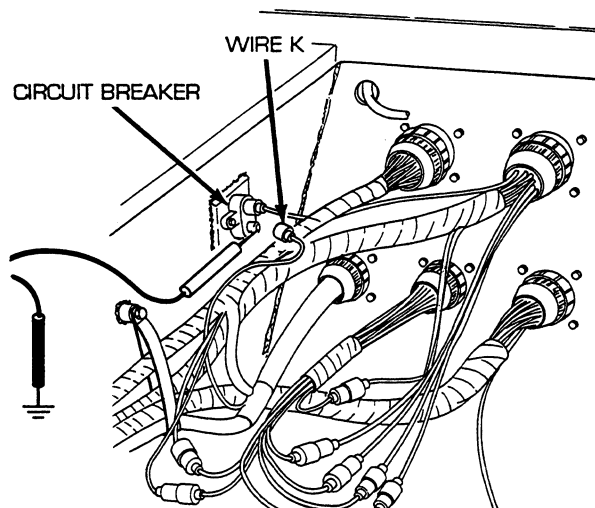

CORRECTIVE ACTION –Continued

7. Reconnect wire K of bulkhead to engine bracket and rear fuel tank transmitter wiring harness to 15 A circuit breaker. Remove engine deck (see WP 0336 00). Disconnect wire K of batteries to master relay voltage regulator and slave receptacle wiring harness at connector near engine disconnect bracket. Place red lead of multimeter in female connector of wire K and black lead to ground. Turn MASTER switch on and check for voltage. Turn MASTER switch OFF. If voltage is present, go to step 8. If voltage is not present, repair/replace wire K of bulkhead to engine bracket and rear fuel tank transmitter wiring harness from 15 A circuit breaker to connector (see WP 0222 00 for dual voltage; 0223 00 for single voltage).

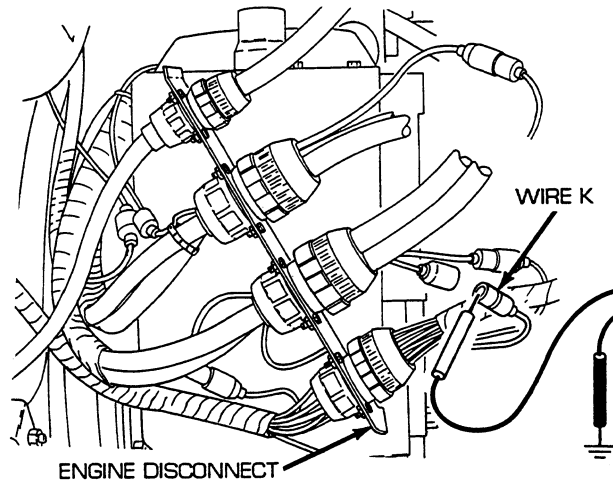

8. Reconnect wire K of batteries to master relay, voltage regulators, slave receptacle, and engine disconnect wiring harness at connector. Disconnect batteries to master relay, voltage regulators, slave receptacle, and engine disconnect wiring harness from engine disconnect bracket. Place red lead of multimeter in socket A of wire K and black lead to ground. Turn MASTER switch on and check for voltage. Turn MASTER switch OFF. If voltage is present, go to step 9. If voltage is not present, repair/replace wire K of batteries to master relay, voltage regulators, slave receptacle, and engine disconnect wiring harness (see WP 0190 00 for dual voltage; 0191 00 for single voltage).

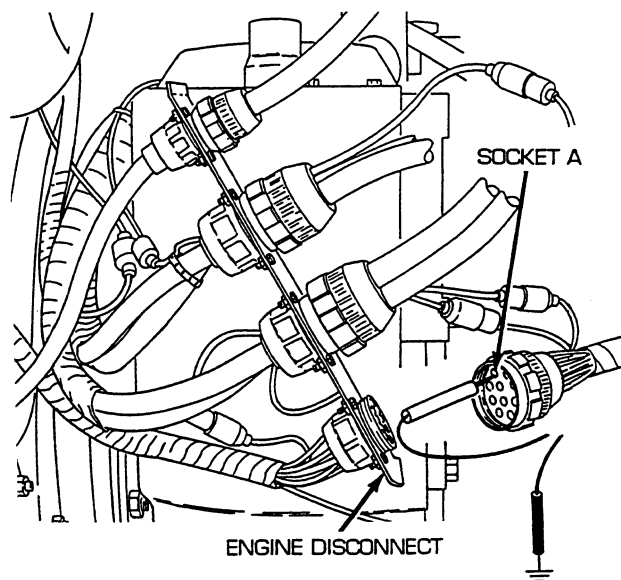

CORRECTIVE ACTION –Continued

9. Reconnect batteries to master relay, voltage regulators, slave receptacle, and engine disconnect wiring harness to engine disconnect. Disconnect wire K of starter module wiring harness from engine wiring harness near engine disconnect. Place red lead of multimeter in female connector of wire K and black lead to ground. Turn MASTER switch on and check for voltage. Turn MASTER switch OFF. If voltage is present, repair/replace wire K of engine wiring harness (see WP 0207 00 for dual voltage; 0208 00 for single voltage). If voltage is not present, repair/replace wire K of module starter wiring harness (see WP 0189 00).

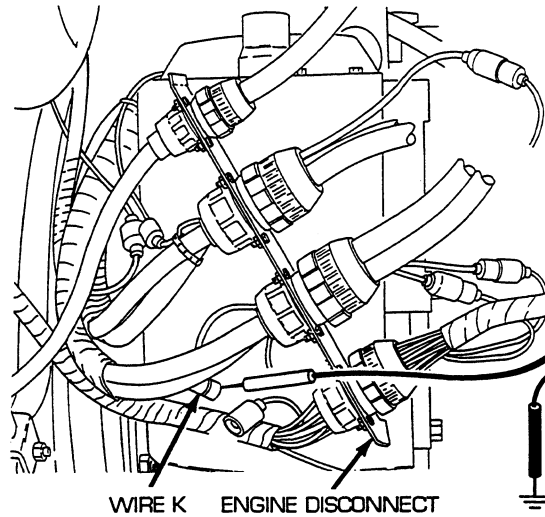
**END OF WORK PACKAGE**

CHAPTER 3
UNIT MAINTENANCE
MAINTENANCE INSTRUCTIONS
FOR
VEHICLE MAINTENANCE
RECOVERY VEHICLE, FULL TRACKED: MEDIUM, M88A1
(NSN: 2350-00-122-6826)

CHAPTER 3
UNIT MAINTENANCE
MAINTENANCE INSTRUCTIONS

WORK PACKAGE INDEX

<u>Title</u>	<u>WP Sequence No.</u>
Service Upon Receipt.....	0094 00
Preventive Maintenance Checks and Services PMCS Procedures Introduction.....	0095 00
Preventive Maintenance Checks and Services.....	0096 00
Lubrication Instructions.....	0097 00

UNIT MAINTENANCE
RECOVERY VEHICLE, FULL TRACKED: MEDIUM, M88A1
NSN 2350-00-122-6826, EIC AQA

SERVICE UPON RECEIPT

INITIAL SETUP:**Tools and Special Tools**

Tool kit, general mechanic's (item 59, WP 0490 00)

Materials/Parts

Compound, cleaning (item 9, WP 0489 00)

References

DA Form 2258
 DA Form 2404

References (cont.)

DA Form 5504
 DA PAM 738-750
 SF Form 364
 TM 9-2350-256-10
 TM 9-6140-200-14
 WP 0096 00
 WP 0097 00

Service Upon Receipt of Materiel**Unpacking****GENERAL**

1. If the vehicle has been shipped by rail, unblock and unload the shipment observing existing regulations. Perform a run-in test of at least 5 miles (8 kilometers [km]) on all new, rebuilt, or overhauled vehicles, and a sufficient number of miles on used vehicles to completely check their operation.

WARNING

Do not use mineral spirits or paint thinner to clean the M88A1. Mineral spirits and paint thinners are highly toxic and combustible. Prolonged breathing can cause dizziness, nausea, and even death. Do not use these materials.

WARNING

Solvents can burn easily, give off harmful vapors, and are harmful to skin and clothing. To avoid injury or death, keep away from open flame and use in a well-ventilated area. If solvent gets on skin or clothing, wash immediately with soap and water.

2. If any exterior surfaces are coated with rust preventive compound, remove it with cleaning compound (item 9, WP 0489 00). Whenever possible, the vehicle crew will help perform these services.

Checking Unpacked Equipment

1. Inspect the equipment for damage incurred during shipment. If the equipment has been damaged, report the damage on SF Form 364 (Record of Discrepancy).
2. Check the equipment against the packing slip to see if the shipment is complete. Report all discrepancies in accordance with instructions on DA PAM 738-750.

Processing Unpacked Equipment

ASSEMBLY OF MISCELLANEOUS VEHICLE COMPONENTS

1. Attach the left and right fenders to the fender brackets with the hardware contained in the package stowed in the crew compartment.
2. Remove bolt from entry door on left side of vehicle and open all hatches and doors.
3. Remove components and support item boxes from interior of vehicle.
4. Remove tape and protective paper from seats and backrests.
5. Remove tape from all lamp lenses and vision blocks.
6. Remove screens and replace covers on all access openings on underside of hull.
7. Open components and support item boxes and inventory contents with packing list furnished with each container. Record missing items.
8. Install radio, periscopes, night viewer, and machine gun mount as required.
9. Remove sealing from battery vent plugs, add electrolyte, charge (refer to TM 9-6140-200-14).

PRE-OPERATIONAL CHECKOUT

1. Drain power takeoff lubricant to operating level.
2. Perform before-operation preventive maintenance checks and services (refer to TM 9-2350-256-10).
3. Check lubricant level in engine, transmission, and auxiliary power unit. Check DA Form 2258 (Depreservation Guide for Vehicles and Equipment) to assure proper lubricant.
4. Perform complete lubrication in accordance with TM 9-2350-256-10 and WP 0097 00.
5. Check operation of all controls.
6. Start engine and check immediately for generator blower operation and for fuel and oil leaks.

NOTE

Due to internal processing, engine may start hard, smoke excessively, and run erratically. However, conditions should greatly improve after five minutes running time. Failure to obtain full engine power will necessitate performing troubleshooting procedures to isolate and correct problem.

7. Repeat above step for the Auxiliary Power Unit (APU).
8. Perform complete TM 9-2350-256-20 PMCS and road test as outlined in this manual. Record all equipment faults on DA Form 2404 (Equipment Inspection and Maintenance Worksheet).

VEHICLE ROAD TEST

Refer to TM 9-2350-256-10 for vehicle operating instructions. Road test long enough to make sufficient observations that operation is normal (5 to 10 miles [8 to 16 km]) for new, rebuilt, or overhauled vehicles. Observe instrument panel gages and warning lights during road test. Do not travel at excessive speeds, accelerate rapidly, or in any way load the engine or power train to capacity during break-in period. Stop at least every mile and observe external parts of vehicle. Check for loose parts, lubricant leaks, and overheated hubs on roadwheels, support rollers, and compensating idler wheels.

AFTER ROAD TEST

Upon completion of road test, perform TM 9-2350-256-10 PMCS.

NOTE

Main engine, transmission, auxiliary power unit engine, power takeoff, winch gearcases, and hydraulic reservoir will not be drained unless expected temperatures require drain and fill with different viscosity oil. Refer to WP 0097 00 for detailed instructions. The preservative oil in the transmission is good for 100 miles (160 km) and should not be drained during vehicle deprocessing.

CORRECTION OF DEFICIENCIES

Equipment faults found during deprocessing or during break-in period will be corrected. Service equipment faults which appear to involve unsatisfactory design or material will be reported on DA Form 5504 (Maintenance Request), as prescribed in DA-PAM 738-750.

Preliminary Servicing of Equipment**Servicing of Equipment****General**

Complete lubricating instructions are contained in TM 9-2350-256-10 and WP 0097 00 which prescribes cleaning and lubricating procedures including locations, intervals, and the proper materials. Lubrication will be performed in accordance with TM 9-2350-256-10, the Maintenance Allocation Chart (WP 0096 00), and WP 0097 00. Whenever necessary, the driver and crew will assist Unit Maintenance personnel.

Special Instructions

Any special lubricating instructions for specific mechanisms or parts are covered in TM 9-2350-256-10.

Service Intervals

Service intervals specified in TM 9-2350-256-10 and WP 0097 00 are for normal operation and where moderate temperature, humidity, and atmospheric conditions prevail. For lubrication procedures and instructions under unusual conditions refer to TM 9-2350-256-10.

Oil Analysis

Oil sampling of engine and transmission will be conducted as prescribed in DA PAM 738-750 (Army Oil Analysis Program). Sampling will be done every 25 hours of engine and transmission or every 30 days, whichever comes first, or as directed by the servicing oil analysis laboratory.

Reports and Records

Report unsatisfactory performance of prescribed petroleum fuels, lubricants, or preserving materials, using DA Form 5504 (Maintenance Request).

END OF WORK PACKAGE

UNIT MAINTENANCE
RECOVERY VEHICLE, FULL TRACKED: MEDIUM, M88A1
NSN 2350-00-122-6826, EIC AQA

PREVENTIVE MAINTENANCE CHECKS AND SERVICES PMCS PROCEDURES INTRODUCTION

General**Introduction**

To ensure that the M88A1 Recovery Vehicle is ready for operation at all times it must be inspected systematically so that defects may be discovered and corrected before they result in serious damage or failure. WP 0096 00 contains a tabulated listing of preventive maintenance checks and services to be performed by Unit Maintenance personnel. All deficiencies and shortcomings will be recorded as well as corrective action taken of DA Form 2404 at the earliest possible opportunity.

Preventive Maintenance Checks and Services

The item numbers within WP 0096 00 indicate the sequence of the PMCS. Perform at the intervals shown below:

1. Do your (Q) preventive maintenance once each 3 months.
2. Do your (S) preventive maintenance twice a year, or each 6 months.
3. Do your (A) preventive maintenance once each year.
4. Do your (B) preventive maintenance once each two years.
5. Do your (H) preventive maintenance at the hour interval listed.
6. Do your (MI) preventive maintenance when the mileage/kilometers of the vehicle reaches the amount listed.

If something doesn't work, troubleshoot it with the instructions in this manual and notify your supervisor.

Always do your preventive maintenance in the same order, so it gets to be a habit. Once you've had some practice, you'll spot anything wrong in a hurry.

If anything looks wrong and you can't fix it, write it down on your DA Form 2404. If you find something seriously wrong, report it to Direct Support Maintenance as soon as possible.

NOTE

Solvents can burn easily, give off harmful vapors, and are harmful to skin and clothing. To avoid injury or death, keep away from open flame and use in a well-ventilated area. If solvent gets on skin or clothing, wash immediately with soap and water.

Keep it clean: Dirt, grease, oil, and debris only get in the way and may cover up a serious problem. Clean as you work and as needed. Use cleaning compound (item 9, WP 0489 00) to clean metal surfaces. Use soap and water to clean rubber or plastic material. Keep all air ducts clear of foreign matter. Special cleaning instructions are given, when necessary, in the pertinent sections.

Bolts, nuts, and screws: Check that they are not loose, missing, bent, or broken. You can't try them all with a tool, of course, but look for chipped paint, bare metal, or rust around bolt heads. Tighten any that you find loose.

Welds: Look for loose or chipped paint, rust, or gaps where parts are welded together. If you find a bad weld, report it to Direct Support Maintenance.

Electric wires and connectors: Look for cracked or broken insulation, bare wires, and loose or broken connectors. Tighten loose connections and make sure the wires are in good condition.

Hoses and fluid lines: Look for wear, damage, and leaks. Make sure clamps and fittings are tight. Wet spots show leaks, of course, but a stain around a fitting or connector can also mean a leak. If a leak comes from a loose fitting or connector, tighten it. If something is broken or worn out, either correct it or report it to Direct Support Maintenance (see MAC chart, WP 0488 00).

It is necessary for you to know how fluid leaks affect the status of your equipment. The following are definitions of the types/classes of leakage you need to know to be able to determine the status of your equipment. Learn and be familiar with them and remember—When in doubt, notify your supervisor.

CAUTION

Equipment operation is allowable with minor leakage (Class I or II) with exception of fuel leaks. Consideration must be given to fluid capacity in item/system being checked/inspected. When in doubt, notify your supervisor.

CAUTION

When operating with Class I or II leaks, continue to check fluid levels as required in your PMCS. Class III leaks require corrective action and should be reported to your supervisor.

Leakage definitions for Unit PMCS:

1. CLASS I—Seepage of fluid (as indicated by wetness or discoloration). Not great enough to form drops.
2. CLASS II—Leakage of fluid great enough to form drops but not enough to cause drops to drip from item being checked/inspected.
3. CLASS III—Leakage of fluid great enough to form drops that fall from the item being checked/inspected.

CAUTION

Water may enter the engine exhaust system when washing the vehicle. To prevent this occurrence, tape the exhaust outlets before washing the vehicle, or operate the engine while washing. Care must also be taken to prevent water from entering the personnel heater exhaust tube or auxiliary engine exhaust by covering the exhaust outlets with tape or cap. Do not use high pressure hoses inside the hull.

Unwashed Vehicle. The driver or crew should present the vehicle for scheduled preventive maintenance services in a reasonably clean condition. That is, it should be dry and not caked with mud to such an extent as to seriously hamper inspection and service. However, washing of the vehicle should be avoided immediately prior to an inspection, since certain types of defects such as loose parts and oil leaks may not be noticeable immediately after washing.

Plates. Nameplates, caution plates, and instruction plates found dirty or corroded should be thoroughly cleaned and heavily coated with clear lacquer. Refer to TM 43-0139.

Services. Unit Maintenance services are defined by, and restricted to, the following general procedures:

1. Adjust. Make all necessary adjustments in accordance with instructions contained herein.
2. Special lubrication. Special lubrication supplies either to lubrication operations that do not appear in TM 9-2350-256-10, or to items that do appear, but which should be performed in connection with the maintenance operations.
3. Service. Servicing usually consists of performing special operations, such as replenishing battery water, draining and refilling units with oil, and changing the oil filters, fuel filters, and air cleaner filters.
4. Tighten. Tighten all units to torque specified herein or, if not specified, tighten to accepted practices. Use a torque wrench where specified. Do not over tighten, as this may strip threads or cause distortion. Tightening includes the correct installation of lockwashers, nuts lockwire, or cotter pins to secure the tightened nut or bolt in place.

Special Conditions. When conditions make it difficult to perform the complete preventive maintenance procedure on the vehicle at one time, the procedure can be handled in sections. Plan to complete all operations within the week, if possible. All available time must be utilized, if necessary, to assure that maintenance operations are completed.

Special Intervals

Operation under adverse conditions, such as extreme temperatures, dust, or mud may require more frequent services. Commanders are authorized to reduce the intervals between preventive maintenance services whenever conditions warrant.

When mileage is accumulated rapidly, the appropriate preventive maintenance services will be performed at the commander's discretion.

After operation in water, mud, or loose sand, the vehicle should be cleaned of any foreign matter as soon as possible and lubricated.

General Procedures

Automatically Applied. The general listed procedures in TM 9-2350-256-10 will be followed. Unit Maintenance mechanics must be so thoroughly trained in these procedures that they apply them automatically at all times in the performance of their duties.

Driver/Crew Participation. The driver or crew usually accompanies the vehicle and assists the Unit Maintenance mechanics in performance of these services.

END OF WORK PACKAGE

UNIT MAINTENANCE
RECOVERY VEHICLE, FULL TRACKED: MEDIUM, M88A1
NSN 2350-00-122-6826, EIC AQA
PREVENTIVE MAINTENANCE CHECKS AND SERVICES

INITIAL SETUP:**Tools and Special Tools**

Tool kit, general mechanic's (item 59, WP 0490 00)
 Gage, wear, end connector (item 17, WP 0490 00)
 STE/ICE-R kit (item 57, WP 0490 00)

Materials/Parts

Compound, cleaning (item 9, WP 0489 00)
 Oil, lubricating (item 22, WP 0489 00)

References

WP 0097 00
 WP 0099 00
 WP 0103 00
 WP 0128 00
 WP 0129 00
 WP 0132 00
 WP 0144 00

References (cont.)

WP 0149 00
 WP 0153 00
 WP 0276 00
 WP 0277 00
 WP 0284 00
 WP 0285 00
 WP 0332 00
 WP 0357 00
 WP 0361 00
 WP 0364 00
 WP 0400 00
 WP 0414 00
 WP 0420 00
 TM 9-2350-256-10
 TM 9-6140-200-14

Table 1. Preventive Maintenance Checks and Services for the M88A1

ITEM NO.	INTERVAL	MAN-HOUR	ITEM TO BE CHECKED OR SERVICED	PROCEDURE	EQUIPMENT NOT READY AVAILABLE IF:
1	S		Fenders	a. Inspect for dents, cracks, breaks, or other damage.	
2	S		Tracks	a. Check track adjustment and adjust as necessary. b. Check end connectors for wear using end connector wear gage. Proceed as follows: <ol style="list-style-type: none"> 1) Place locator of end connector wear gage (item 17, WP 0490 00) over protruding end of track link pin. 2) Depress pin of gage and observe whether pin touches end connector. 3) Rotate gage around end surface of connector and measure wear in various locations. 4) If end of gage pin fails to touch surface of connector at any point when gage is fully depressed, end connector is excessively worn and must be replaced. 	End connector unserviceable.

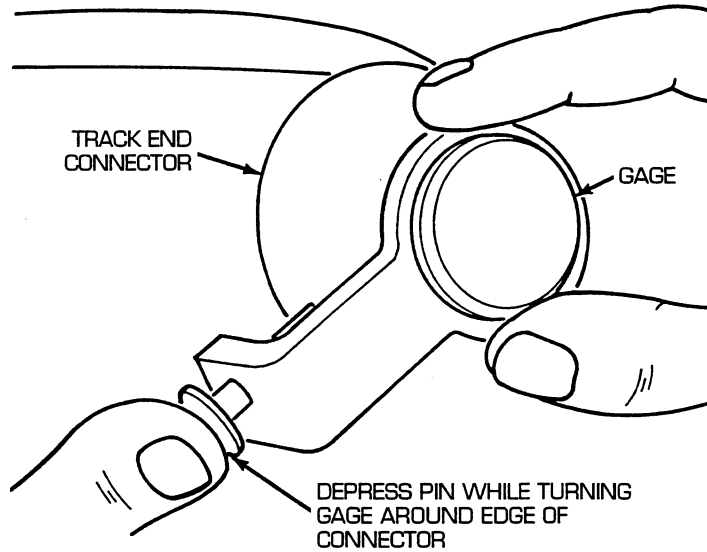

ITEM NO.	INTERVAL	MAN-HOUR	ITEM TO BE CHECKED OR SERVICED	PROCEDURE	EQUIPMENT NOT READY AVAILABLE IF:
----------	----------	----------	--------------------------------	-----------	-----------------------------------

3 S Sprockets

NOTE

Refer to WP 0283 00 for removal and installation instructions.

- a. Inspect sprockets (1) for cracks and breaks and replace where needed.
- b. Check sprocket teeth for wear. If only forward side of sprocket tooth is worn to limit, reverse inner and outer sprockets.
- c. Tighten loose mounting bolts to 225–250 pound-feet (lb-ft) (305–339 newton-meters [N•m]).

Both sides of teeth are worn.

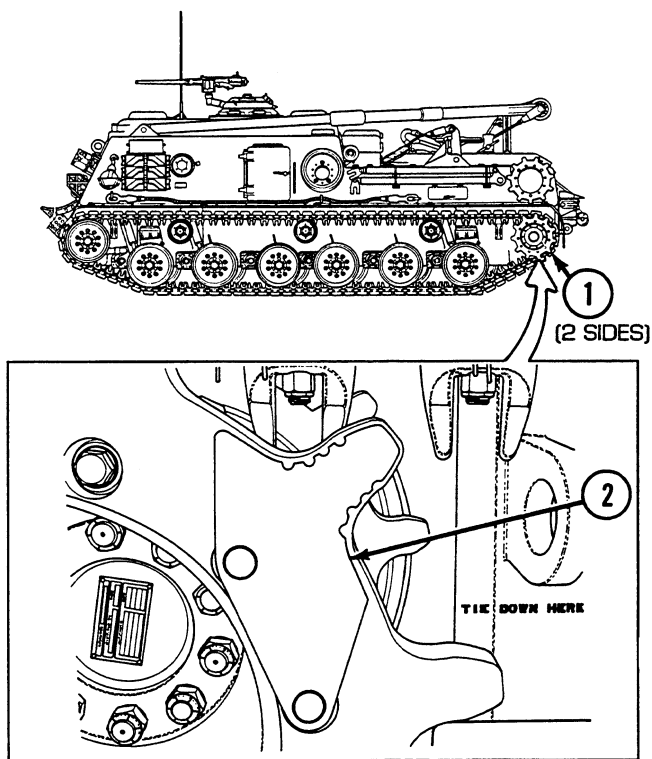

ITEM NO.	INTERVAL	MAN-HOUR	ITEM TO BE CHECKED OR SERVICED	PROCEDURE	EQUIPMENT NOT READY AVAILABLE IF:
----------	----------	----------	--------------------------------	-----------	-----------------------------------

4			Wheel Arms and Hubs		
---	--	--	---------------------	--	--

WARNING

Be careful when feeling wheel hubs. They can heat up enough to cause burns.

NOTE

Prior to performing this check, the vehicle must be operated for 5–10 minutes.

- a. Visually inspect arms and hubs for lubricant leaks.
- b. Replace seals and/or gaskets where leaks are evident. Refer to WP 0276 00 and 0277 00 for detailed removal and installation instructions.

Two or more hub seal leaks are found.

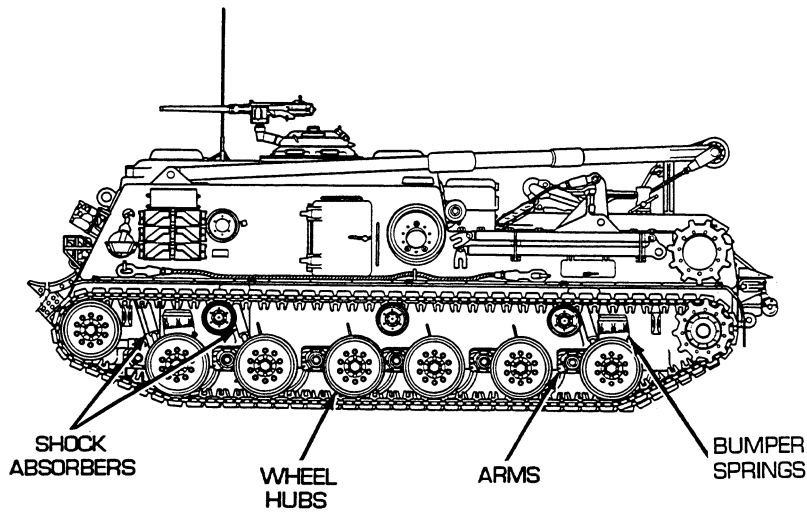

ITEM NO.	INTERVAL	MAN-HOUR	ITEM TO BE CHECKED OR SERVICED	PROCEDURE	EQUIPMENT NOT READY AVAILABLE IF:
----------	----------	----------	--------------------------------	-----------	-----------------------------------

5	S		Shock Absorbers		
---	---	--	-----------------	--	--

WARNING

Be careful when feeling shock absorbers. They can heat up enough to cause burns.

NOTE

Prior to performing this check, the vehicle must be operated for 5–10 minutes.

- a. Attempt to move shock absorbers from side to side. If movement is present, shock absorber bearing or pin is defective. Refer to WP 0285 00 for removal and installation instructions.
- b. Tighten loose mounting bolts. Torque upper bracket bolts (1) to 145–175 lb-ft (197–237 N•m) and lower bracket bolts (2) to 300–340 lb-ft (407–461 N•m).

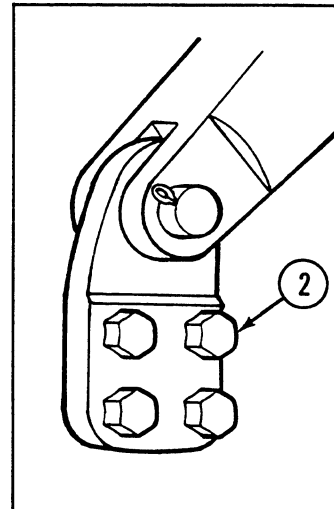
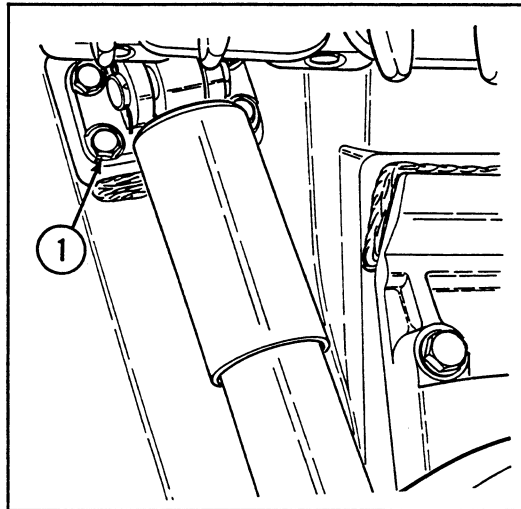

ITEM NO.	INTERVAL	MAN-HOUR	ITEM TO BE CHECKED OR SERVICED	PROCEDURE	EQUIPMENT NOT READY AVAILABLE IF:
----------	----------	----------	--------------------------------	-----------	-----------------------------------

- | | | | | | |
|---|---|--|----------------|--|--|
| 6 | S | | Bumper Springs | <p>a. Visually inspect for broken, cracked, or compressed bumper springs. Refer to WP 0284 00 for removal and installation instructions.</p> <p>b. Tighten loose mounting bolts. Torque bolts (1) to 350–400 lb-ft (475–542 N•m) and bolts (2) to 150–170 lb-ft (203–231 N•m).</p> | |
|---|---|--|----------------|--|--|

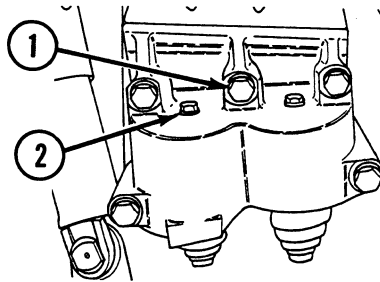

- | | | | | | |
|---|---|--|---------------------|---|--|
| 7 | S | | Torsion Bar Anchors | <p>a. Visually inspect torsion bar anchors to ensure that they are fully seated and retaining screws are in place and secure. Torque screws to 40–50 lb-ft (54–68 N•m).</p> | Two or more torsion bar anchors unserviceable on any one side. |
|---|---|--|---------------------|---|--|

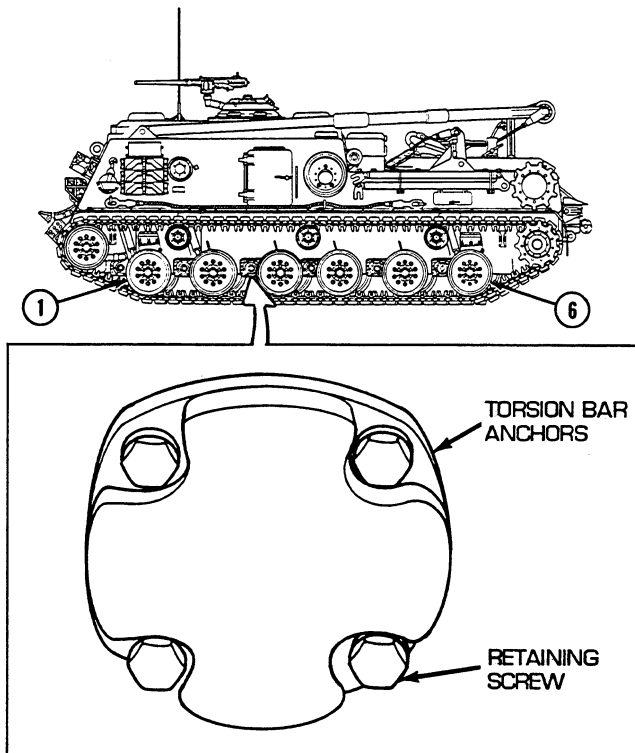

ITEM NO.	INTERVAL	MAN-HOUR	ITEM TO BE CHECKED OR SERVICED	PROCEDURE	EQUIPMENT NOT READY AVAILABLE IF:
8	S		Drain Valves and Drain Valve Seals	a. Operate drain valve lever to assure free operation of two drain valves (located at front and rear of underside of hull). The drain valves should seal openings completely when closed. b. Inspect drain valve bearing surfaces for nicks, dents, scored bearing surface, and out-of-roundness.	

9	S		Decals, Name Plates, Stencils, Markings, and Paint	a. Replace decals and name plates that are not legible.	
---	---	--	--	---	--

CAUTION

High intensity noise hearing protection required (4).

NOTE

Refer to TM 9-213 for painting information and procedures.

b. Restencil markings that are not legible.

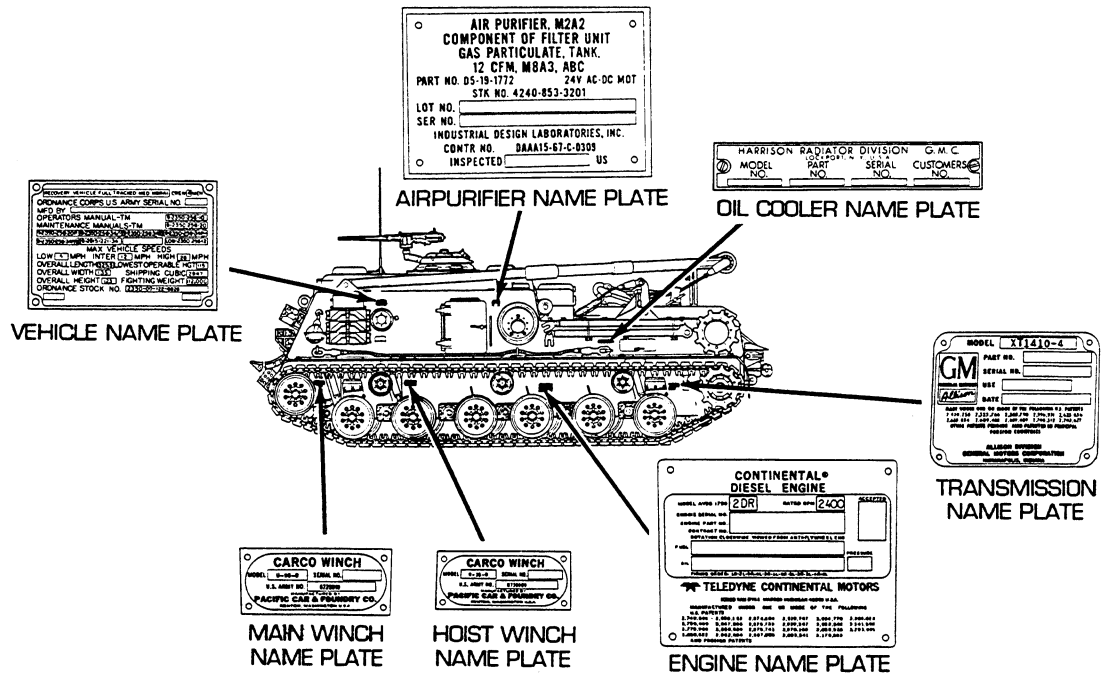

ITEM NO.	INTERVAL	MAN-HOUR	ITEM TO BE CHECKED OR SERVICED	PROCEDURE	EQUIPMENT NOT READY AVAILABLE IF:
----------	----------	----------	--------------------------------	-----------	-----------------------------------

c. Clean and paint bare spots on painted surfaces that might permit reflections, rust or corrosion.

DECAL LOCATION — CREW COMPARTMENT

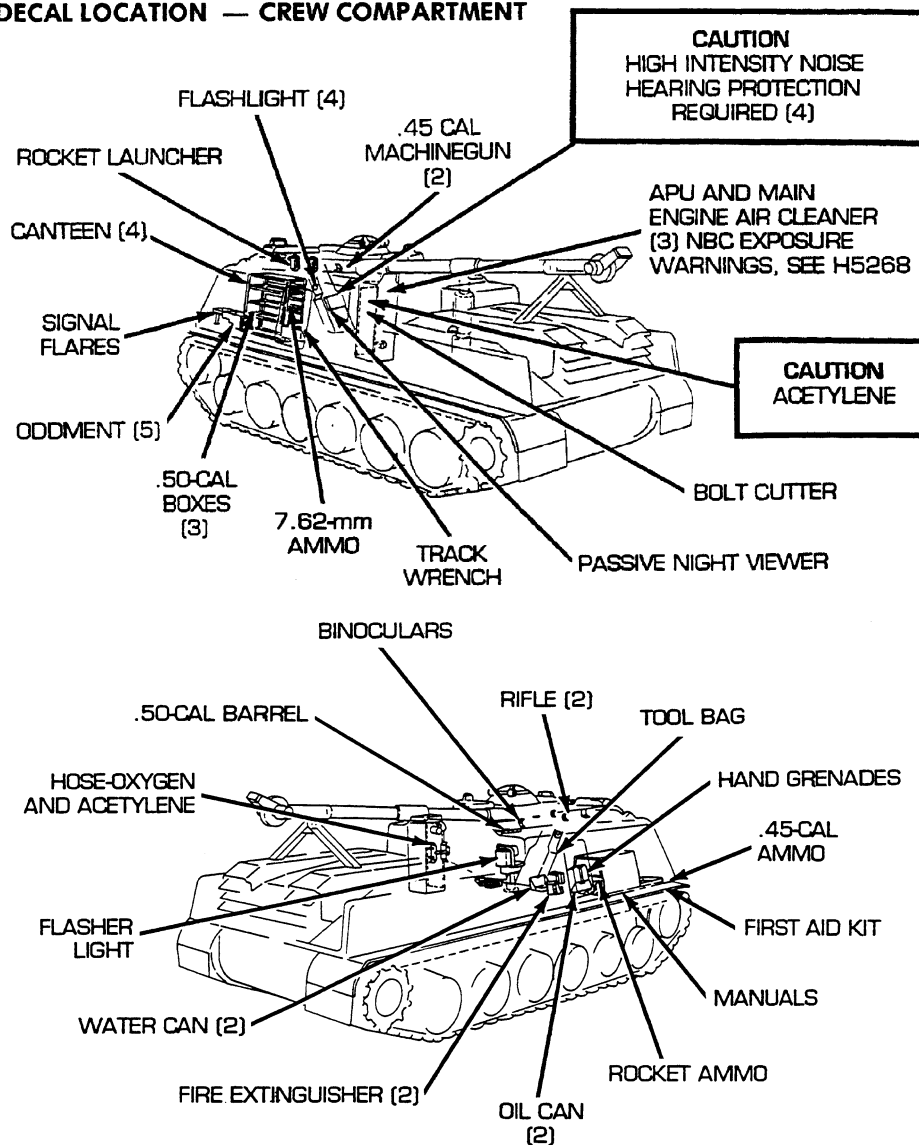

10 S

Access Covers, Seals, Racks, Straps, and Clamps

- a. Check for loose or missing access covers.
- b. Replace defective door seals.
- c. Replace defective straps and retaining clamps.

ITEM NO.	INTERVAL	MAN-HOUR	ITEM TO BE CHECKED OR SERVICED	PROCEDURE	EQUIPMENT NOT READY AVAILABLE IF:
11	S		Commander's Cupola	a. Rotate cupola to ensure that ring does not bind. b. Operate cupola door latches and locks in open and closed positions to assure ease of operation. c. Check seals and crash pads for tears and deterioration. d. Check that vision blocks are free of fungus growth, chips, fractures, and separation that would interfere with vision.	Will not lock open or closed.
12	S		Machine Gun Mount .50-Cal-iber	a. With machine gun installed, elevate and depress mount to full range (93° elevation and 21° depression). b. Check for weak or faulty equilibrator action.	

WARNING

Solvents can burn easily, can give off harmful vapors, and are harmful to skin and clothing. To avoid injury or death, keep away from open flame and use in a well-ventilated area. If solvent gets on skin or clothing, wash immediately with soap and water.

- c. Clean mount with cleaning compound (item 9, WP 0489 00).
- d. Lubricate all moving parts with lubricating oil (item 22, WP 0489 00).

ITEM NO.	INTERVAL	MAN-HOUR	ITEM TO BE CHECKED OR SERVICED	PROCEDURE	EQUIPMENT NOT READY AVAILABLE IF:
----------	----------	----------	--------------------------------	-----------	-----------------------------------

13	S		M239 Smoke Grenade Launcher System		
----	---	--	------------------------------------	--	--

NOTE

Refer to TM 3-1040-266-20&P for additional PMCS instructions.

- a. Inspect condition of cables for fraying, or broken wires, and for tightness of fit in connectors.
- b. Check spring return action of push button firing switches, and switching action of toggle switch.
- c. Check light bulb in power (arming) switch assembly.

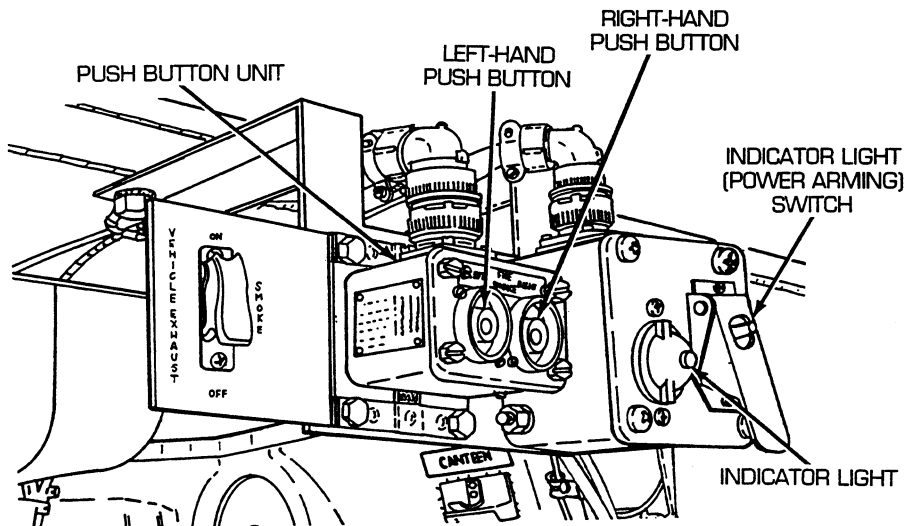

WARNING

Remove all jewelry such as rings, dog tags, bracelets, etc. If jewelry contacts a metal surface a direct short may result in instant heating of tools, damage to equipment, and injury or death to personnel.

ITEM NO.	INTERVAL	MAN-HOUR	ITEM TO BE CHECKED OR SERVICED	PROCEDURE	EQUIPMENT NOT READY AVAILABLE IF:
----------	----------	----------	--------------------------------	-----------	-----------------------------------

- d. Perform continuity checks on system as follows:
- 1) Place MASTER switch in ON position.
 - 2) Place power (arming) switch in ON position.
 - 3) Depress and hold L hand push button.
 - 4) Check to see if approximately 24 volts exists on plug pins in tubes (5, 2, and 1) on left discharger and (3, 6, and 4) on right discharger. No voltage should exist on any other plug pins.
 - 5) Release L hand push button and depress and hold R hand push button.
 - 6) Check to see if approximately 24 volts exists on plug pins in tubes (3, 6, and 4) on left discharger and (5, 2, and 1) on right discharger. No voltage should exist on any other plug pins.

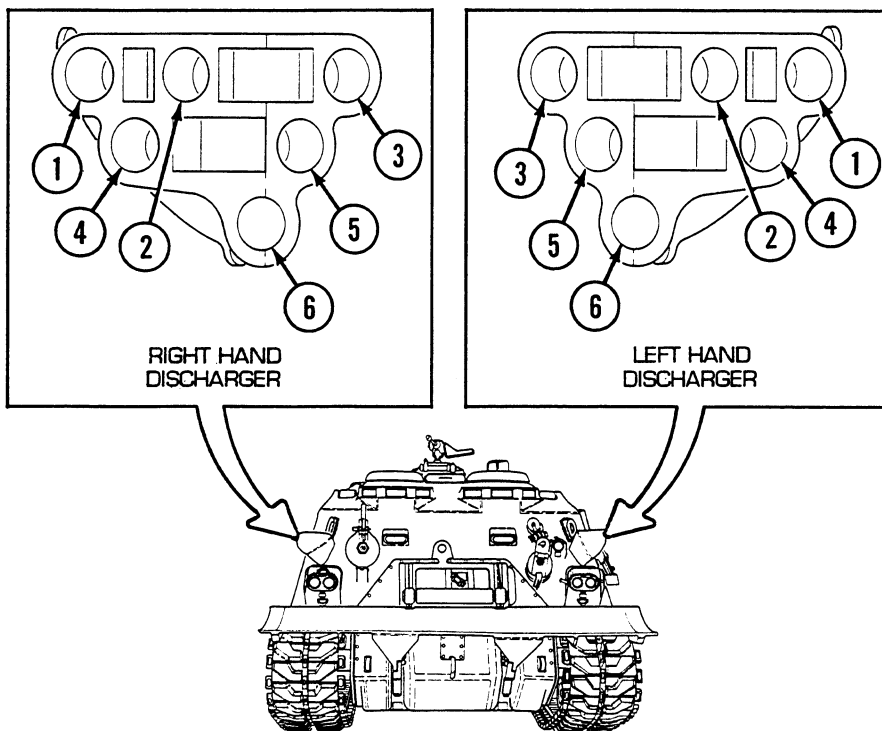

ITEM NO.	INTERVAL	MAN-HOUR	ITEM TO BE CHECKED OR SERVICED	PROCEDURE	EQUIPMENT NOT READY AVAILABLE IF:
----------	----------	----------	--------------------------------	-----------	-----------------------------------

14 S

APU

- a. Start engine. Listen for unusual noises in engine and generator which might indicate improper operation.
- b. Observe warning lights and oil pressure gage to see if unit is functioning properly. Oil pressure gage should indicate approximately between 30–45 pounds per square inch (psi) (207–310 kilopascals [kPa]).
- c. Service primary fuel filter. Replace filter semiannually.
- d. Service secondary fuel filter. Replace filter semiannually.
- e. Tighten fuel, oil, and air connections that leak.
- f. Inspect air system components and replace if damaged or deteriorated.

APU not serviceable.

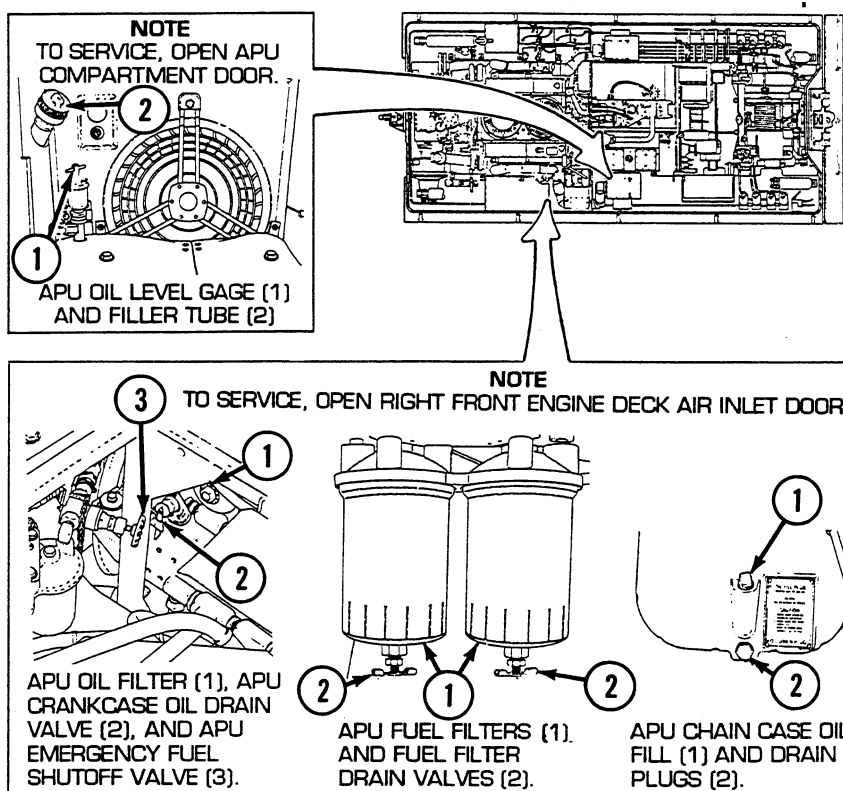

ITEM NO.	INTERVAL	MAN-HOUR	ITEM TO BE CHECKED OR SERVICED	PROCEDURE	EQUIPMENT NOT READY AVAILABLE IF:
----------	----------	----------	--------------------------------	-----------	-----------------------------------

15 S

Acetylene Hose and Adapter

a. Inspect acetylene hose, adapter, and related parts for leaks and damage. Replace defective parts in accordance with WP 0332 00.

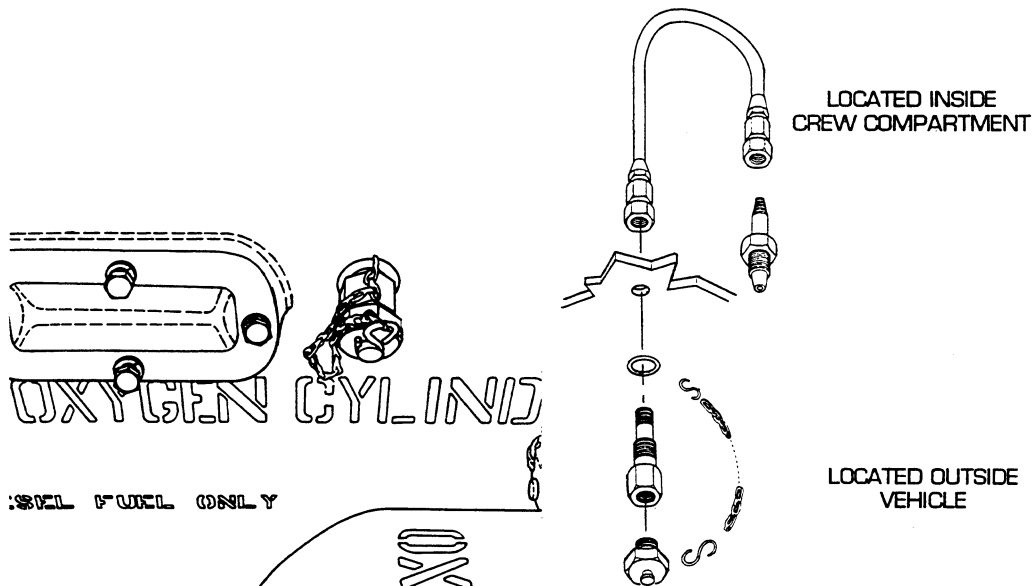

16 S

Stowage Boxes

a. Inspect and repair locks and hinges.
b. Tighten loose mounting bolts.

17 S

Seats

a. Inspect seats for torn cushions and backrests.
b. Check adjusting mechanisms and trip levers for smooth operation.

ITEM NO.	INTERVAL	MAN-HOUR	ITEM TO BE CHECKED OR SERVICED	PROCEDURE	EQUIPMENT NOT READY AVAILABLE IF:
----------	----------	----------	--------------------------------	-----------	-----------------------------------

18 S Fixed Fire Extinguisher System

NOTE

A cylinder must be recharged or replaced if its weight loss exceeds 10 percent of difference between full and empty weight marked on cylinder. Hydrostatic test cylinders if either 10 years have passed since last static test and cylinders have not been discharged or cylinders have been used within 5 years since last test.

- a. Remove and weight each cylinder. Refer to WP 0400 00 for removing, weighing, and installing instructions.
- b. Inspect the fire extinguisher data plate to ensure that hydrostatic tests have been performed on each cylinder in the past five years.
- c. Clean cylinder discharge nozzles of foreign matter.
- d. Before replacing fixed fire extinguisher cylinders, operate remote control discharge handles to make sure that cables do not bind and that they control discharge function properly.
- e. Seal remote control handles before checking system.
- f. Ensure fire extinguisher interlock switch assembly is operating properly by pulling out safety pin and letting cover plate swing down. A clicking sound should be heard.

Cable binds, or will not operate smoothly.

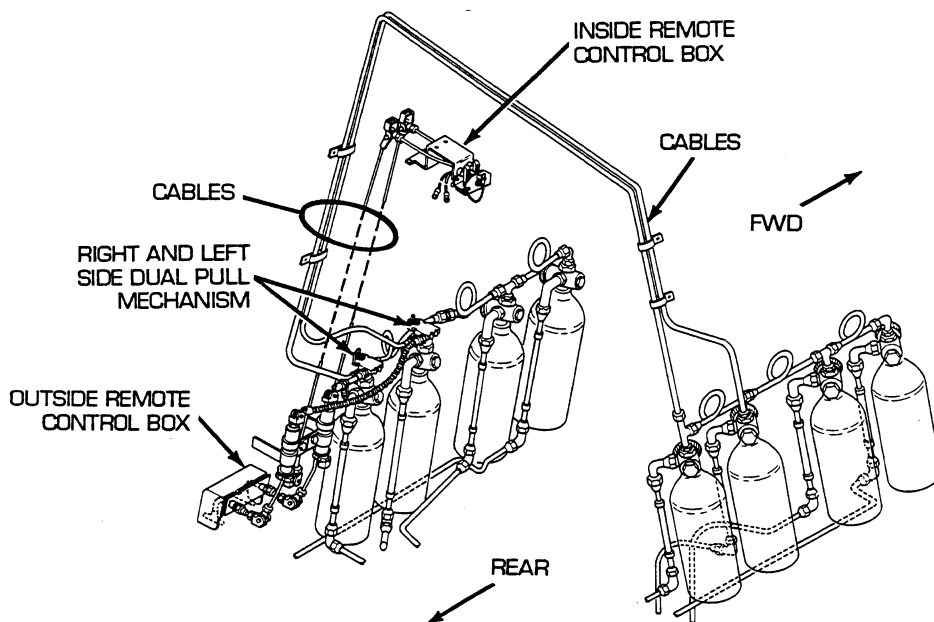

ITEM NO.	INTERVAL	MAN-HOUR	ITEM TO BE CHECKED OR SERVICED	PROCEDURE	EQUIPMENT NOT READY AVAILABLE IF:
19	S		Steering	a. With vehicle operating in moderate speed and steering control centered, check for any tendency to wander or pull to one side. If either of these conditions exist, check steering controls and linkage adjustment in accordance with WP 0357 00.	
20	S		Brakes	a. Accelerate vehicle to 15 miles per hour (mph) (24 kilometers per hour [kph]) and do the following: 1) Release accelerator and apply brakes. 2) Observe if vehicle stops effectively without pulling to one side. Vehicle must stop within 4 feet (ft) (1.2 meters [m]), when stopping at 15 mph (24 kph). b. With vehicle on an incline, do the following: 1) Depress brake pedal and move transmission shift lever to park position. 2) Observe if brakes lock securely and vehicle is held in place.	Brakes do not operate properly.
21	S		Transmission	a. Shift through all forward and reverse speed ranges and notice if transmission shifts smoothly, without excessive vibration or unusual noises, and that response is satisfactory.	
22	S		Accelerator Controls and Linkages		

CAUTION

If governor malfunctions, engine speed must not exceed 2640 rpm for more than 2 or 3 seconds.

- a. Move the accelerator through its entire range and observe if engine rpm response is satisfactory.
 - b. With the transmission lever in neutral position, the engine should idle smoothly between 675 and 725 rpm.
 - c. Adjust accelerator controls and linkages in accordance with WP 0364 00.
- Idle is not between 675 and 725 rpm.

ITEM NO.	INTERVAL	MAN-HOUR	ITEM TO BE CHECKED OR SERVICED	PROCEDURE	EQUIPMENT NOT READY AVAILABLE IF:
----------	----------	----------	--------------------------------	-----------	-----------------------------------

23 S Exhaust Smoke Generating System

WARNING

Never activate smoke generator system in a building or closed area, or with personnel at rear of vehicle.

- a. Check that fuel shutoff valve is open.
 - b. Check tightness of all electrical connectors.
 - c. Inspect for evidence of leakage and tighten fuel connections as necessary.
- Any fuel leak is present.

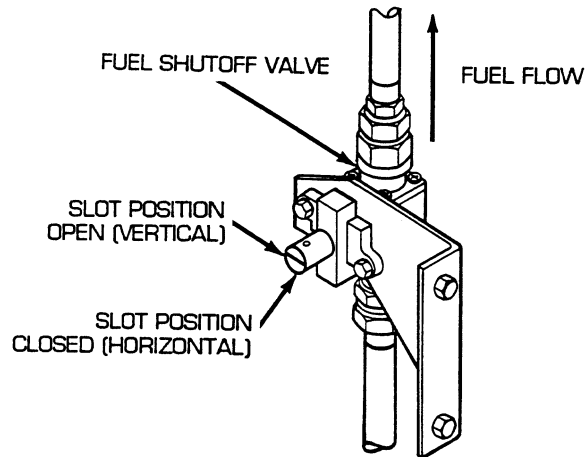

24 S Fuel Filter

NOTE

Remove powerplant (see WP 0098 00).

- a. Replace primary fuel filter (see WP 0128 00).

25 S Fuel/Water Separator a. Replace fuel/water separator filters (see WP 0129 00).

ITEM NO.	INTERVAL	MAN-HOUR	ITEM TO BE CHECKED OR SERVICED	PROCEDURE	EQUIPMENT NOT READY AVAILABLE IF:
----------	----------	----------	--------------------------------	-----------	-----------------------------------

26	S		Oil Coolers	a. Inspect oil coolers for leaks or dirty fins. Repair any leaks authorized for Unit Maintenance.	Cooler damaged, clogged, or leaks are present.
----	---	--	-------------	---	--

WARNING

Wear eye protection when working with pressurized air to prevent debris from causing injury.

- b. Clean dirty fins with low pressure air. Inspect oil cooler lines for holes, rips, and tears. Replace oil cooler lines as necessary in accordance with WP 0149 00.
- c. Inspect oil cooler screens for clogs or holes.

27	S		Cooling Fans	Check engine cooling fans for proper alignment and damage (see WP 0144 00).	Fan damaged or improperly aligned.
----	---	--	--------------	---	------------------------------------

28	S		Manifold Heater	<ul style="list-style-type: none"> a. Replace manifold heater fuel filter (see WP 0132 00). b. Inspect and service manifold heater spark plug. <ul style="list-style-type: none"> 1) Clean electrodes. 2) Clean accumulated grease and dirt from insulators. 3) Install groundhop kit. 4) Start engine. c. Shut off engine before it reaches operating temperature and do the following: 	
----	---	--	-----------------	--	--

WARNING

Be careful when feeling engine. Engine parts can be hot enough to cause burns.

- 1) Using extreme caution, run hand along each intake manifold to check for heat generated by manifold heaters.
- 2) If heaters are operative, heat will be felt.

29	S		Main Engine Oil Filters	a. Replace main engine oil filters (see WP 0103 00).	
----	---	--	-------------------------	--	--

30	S		Main Engine Air Cleaner	<ul style="list-style-type: none"> a. Clean main engine air cleaner (refer to TM 9-2350-256-10). <ul style="list-style-type: none"> 1) Be sure that all joints, seals, and connections are tight and not leaking. 2) Inspect air intake hoses for tears and deterioration. 	Hoses are damaged.
----	---	--	-------------------------	--	--------------------

ITEM NO.	INTERVAL	MAN-HOUR	ITEM TO BE CHECKED OR SERVICED	PROCEDURE	EQUIPMENT NOT READY AVAILABLE IF:
----------	----------	----------	--------------------------------	-----------	-----------------------------------

31 S

Engine Rear Mount and Oil Pan Plug

- a. Check engine rear mount and base assembly for damage.
- b. Check oil pan plug and gasket for leaks.

Class III leak present.

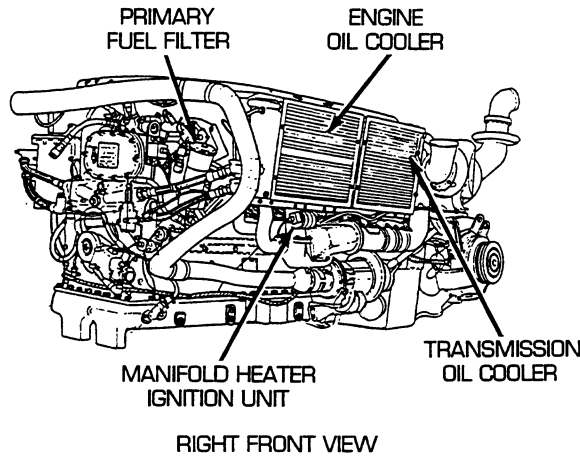
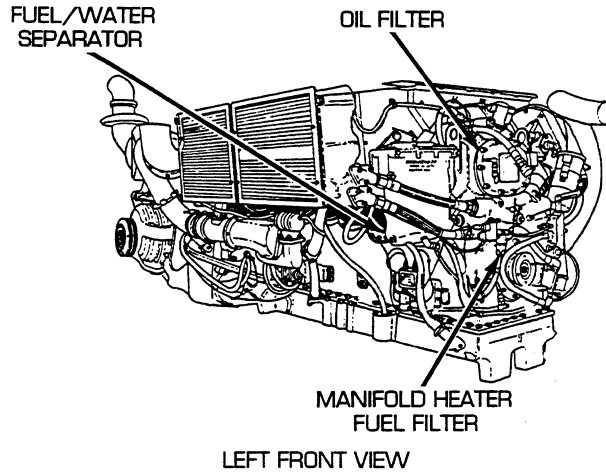

32		Fuel Tanks	a. Check for fuel leaks.	Any fuel leak present.
33		Fuel Manifold	a. Check for fuel leaks. b. With groundhop kit installed (see WP 0099 00), start engine.	Any fuel leak present.

ITEM NO.	INTERVAL	MAN-HOUR	ITEM TO BE CHECKED OR SERVICED	PROCEDURE	EQUIPMENT NOT READY AVAILABLE IF:
----------	----------	----------	--------------------------------	-----------	-----------------------------------

34 S

Fuel Injector Lines, Fuel Return Lines, and Related Parts

a. Immediately inspect fuel injector lines, fuel return lines, fuel control valves, and fuel injector and holder assemblies for leakage.

WARNING

Be careful when feeling engine. Engine parts can be hot enough to cause burns.

b. Check to be sure there is no movement of nozzle head inside outer fuel injector assembly. This inspection can be accomplished by placing hand between the nozzle head and top of the holder before engine temperature rises. If movement of the nozzle is felt, stop engine and notify Direct Support Maintenance.

FUEL RETURN LINES

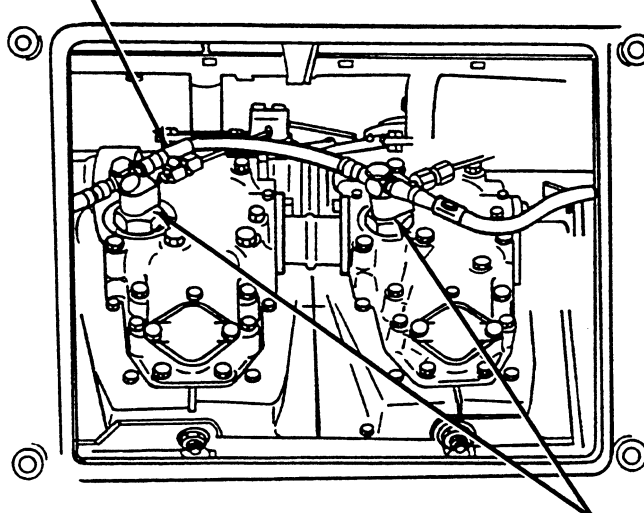

NOZZLE HEAD (2)

ITEM NO.	INTERVAL	MAN-HOUR	ITEM TO BE CHECKED OR SERVICED	PROCEDURE	EQUIPMENT NOT READY AVAILABLE IF:
----------	----------	----------	--------------------------------	-----------	-----------------------------------

35	S		Purge Pump	a. Check operation of purge pump. b. Check connections (1 and 2) for evidence of leakage.	Class III leak present.
----	---	--	------------	--	-------------------------

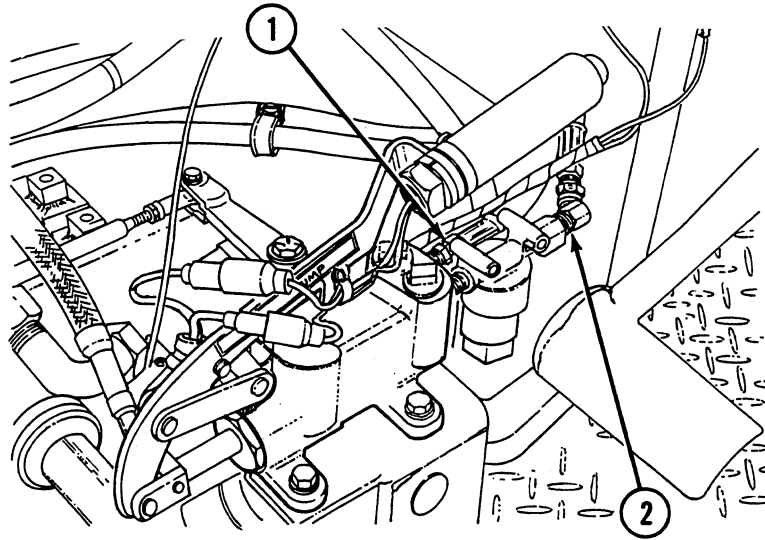

36	S		Starter	a. While starting engine, listen for unusual noises and difficult cranking at starter.	Unusual noises present.
37	S		Generator	a. Listen for unusual noises in engine and generator which might indicate improper operation.	Unusual noises present.
38	S		Exhaust System		

NOTE

Checks below are performed with powerplant installed (see WP 0098 00).

- a. Inspect exhaust system for damaged or deteriorated components. Tighten loose clamps and mounting bolts.

ITEM NO.	INTERVAL	MAN-HOUR	ITEM TO BE CHECKED OR SERVICED	PROCEDURE	EQUIPMENT NOT READY AVAILABLE IF:
----------	----------	----------	--------------------------------	-----------	-----------------------------------

39 S

Engine Fuel Shutoff and Accelerator Controls

a. Start the engine again and perform the following:

- 1) Listen for unusual noises, hesitations, and varying idle speed.
- 2) Check throttle and accelerator controls for smooth operation.
- 3) Check operation of fuel shutoff switch (1), manual fuel shutoff valve (2), and fuel shutoff handle (3).

One switch/valve is inoperable.

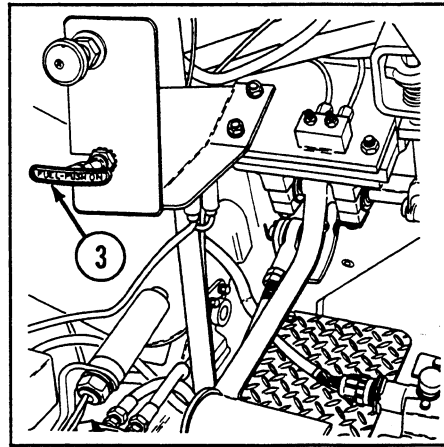
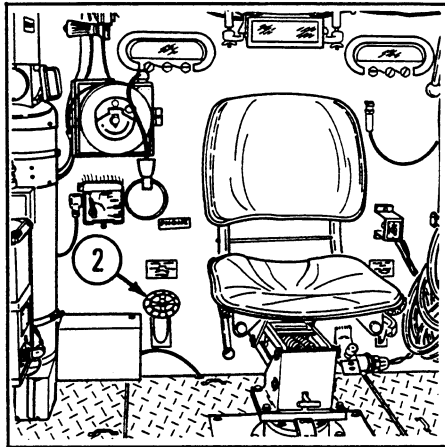
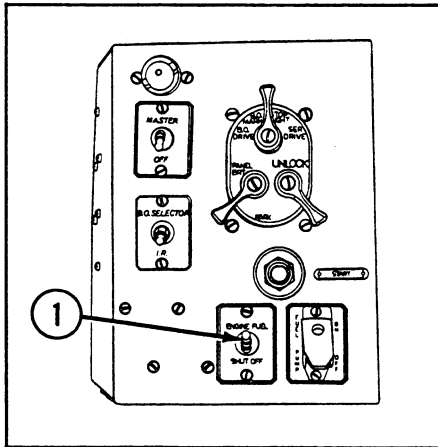

ITEM NO.	INTERVAL	MAN-HOUR	ITEM TO BE CHECKED OR SERVICED	PROCEDURE	EQUIPMENT NOT READY AVAILABLE IF:
----------	----------	----------	--------------------------------	-----------	-----------------------------------

40	S		Governor No-Load Test		
----	---	--	--------------------------	--	--

CAUTION

If governor malfunctions, engine speed must not exceed 2640 rpm for more than 2 or 3 seconds.

a. Perform governor no-load test as follows:

- 1) Run engine until normal operating temperatures (engine oil at 140–240°F [60–116°C], transmission oil at 160–280°F [72–138°C]) are reached.
- 2) With transmission (1) in neutral, gradually open the throttle until the accelerator pedal (2) is fully depressed. Engine speed will generally exceed 2640 rpm momentarily; then speed will stabilize between 2400 and 2640 rpm. If the governor repeatedly cuts in and out or surges, notify Direct Support Maintenance.

Rpm exceeds 2640 or governor cuts in or out, or surges.

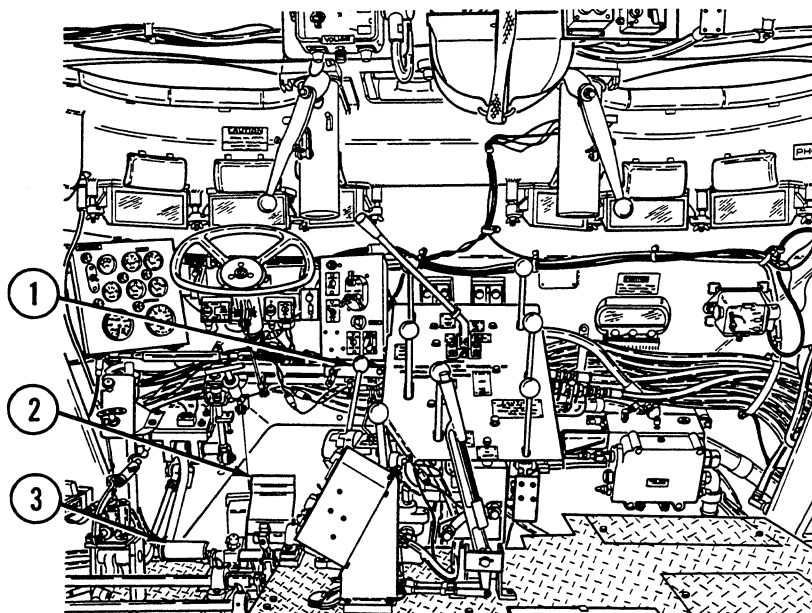

ITEM NO.	INTERVAL	MAN-HOUR	ITEM TO BE CHECKED OR SERVICED	PROCEDURE	EQUIPMENT NOT READY AVAILABLE IF:
----------	----------	----------	--------------------------------	-----------	-----------------------------------

41 S Stall Test

WARNING

Vehicle may move even with brakes in the locked position.

CAUTION

Do not stall test engine for more than 30 seconds, or converter will overheat.

- a. Perform stall test.
 - 1) Run engine until normal operating temperature is reached.
 - 2) Depress brake (3) to lock it in position; place transmission (1) in high range and run the engine at full throttle for 30 seconds.
 - 3) If the engine speed exceeds 1950 rpm, there is a clutch slippage in the transmission. Check the shifting control linkage adjustment (see WP 0361 00).

Rpm below 1800 or above 1950.

42 S Acceleration and Pulling Power Test

NOTE

While testing in low range, accelerate with wide-open throttle from low speed to top speed. Governed speed under load should reach 1875 rpm, but not exceed 2640 rpm. If below 1875 rpm or over 2640, notify Direct Support Maintenance.

- a. Test for normal acceleration and pulling power in each transmission range.

Rpm below 1875 or over 2640.

ITEM NO.	INTERVAL	MAN-HOUR	ITEM TO BE CHECKED OR SERVICED	PROCEDURE	EQUIPMENT NOT READY AVAILABLE IF:
----------	----------	----------	--------------------------------	-----------	-----------------------------------

43	S		Main Hydraulic System		
----	---	--	-----------------------	--	--

WARNING

Do not attempt to loosen or tighten hydraulic fittings or lines when system is pressurized. Be sure that boom and spade are in stored positions before doing any maintenance on hydraulic system.

WARNING

Solvents can burn easily, can give off harmful vapors, and are harmful to skin and clothing. To avoid injury or death, keep away from open flame and use in a well-ventilated area. If solvent gets on skin or clothing, wash immediately with soap and water.

WARNING

Particles blown by compressed air can be dangerous. Be certain to direct airstream away from user and other personnel in the area. Compressed air used for cleaning will not exceed 30 psi (207 kPa). Use only with effective chip-guarding and personnel protective equipment (goggles/shield and gloves).

ITEM NO.	INTERVAL	MAN-HOUR	ITEM TO BE CHECKED OR SERVICED	PROCEDURE	EQUIPMENT NOT READY AVAILABLE IF:
----------	----------	----------	--------------------------------	-----------	-----------------------------------

- a. Service hydraulic reservoir oil filter (see WP 0420 00).
- b. Inspect hydraulic lines and fittings for leaks, damage, and deterioration.
- c. Operate system and check for unusual noises or other defects.

Class III leak present.

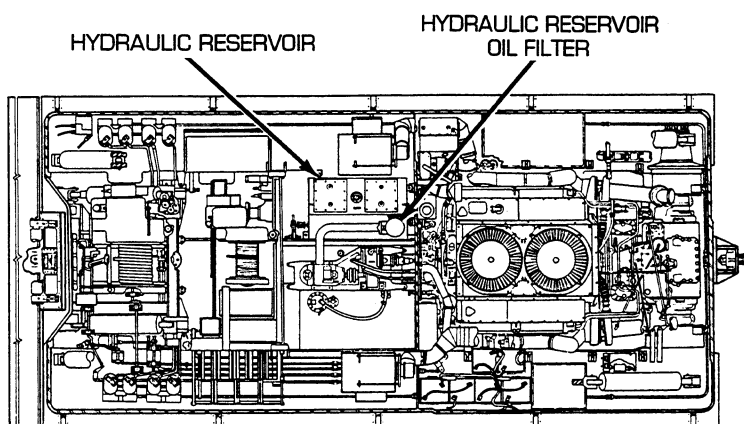

44			Main Winch	a. Clean and lubricate cable (refer to TM 9-2350-256-10).	
45			Hoist Winch	a. Clean and lubricate cable (see WP 0097 00).	
46			Hoisting Boom and Deck Attachments	<ol style="list-style-type: none"> a. Clean and lubricate stayline cable in accordance with WP 0097 00. b. Inspect boom yoke/pulley cotter pins. Replace if damaged or missing (see WP 0414 00). 	Cotter pins missing or damaged.
47			M8A3 Gas/Particulate Filter Unit		

WARNING

The unit commander or senior officer in charge of maintenance personnel assigned to remove and dispose of contaminated gas filters must prescribe necessary protective clothing to be worn during this operation. They must also prescribe necessary safety measures to be followed including the decontamination operation that must be performed before new gas filters are installed in housing assembly (refer to TM 3-220).

- a. Check that air flow is 3.0 to 4.5 standard cubic feet/minute (scf/m) or 2.1 to 4.5 inch water gage (IWG) at each station using the M39 Tester (item 57, WP 0490 00).

ITEM NO.	INTERVAL	MAN-HOUR	ITEM TO BE CHECKED OR SERVICED	PROCEDURE	EQUIPMENT NOT READY AVAILABLE IF:
----------	----------	----------	--------------------------------	-----------	-----------------------------------

48			Batteries	a. Clean batteries, trays, supports, and retainers (see WP 0153 00). b. If supports, trays, and/or retainers are corroded, paint with acid-resistant paint.	
----	--	--	-----------	--	--

NOTE

Batteries are in good condition and serviceable when the specific gravity readings are between 1.250 and 1.300 corrected to 80°F (27°C) (1.200 to 1.225 for batteries used in tropical climates) and the specific gravity between individual cells does not vary by more than 0.040.

c. Test specific gravity of battery electrolyte. Specific gravity shall be a minimum of 1.225 under normal operating conditions and 1.180 under tropical conditions (refer to TM 9-6140-200-14). If specific gravity is unsatisfactory, charge or replace batteries (see WP 0153 00).

Table 1. Specific Gravity—Cold Climate

Specific Gravity (corrected to 80°F [27°C])	Electrolyte Freezing Temperature
1.100	+19°F (-7°C)
1.150	+5°F (-15°C)
1.200	-16°F (-27°C)
1.250	-62°F (-52°C)
1.280	-90°F (-68°C)

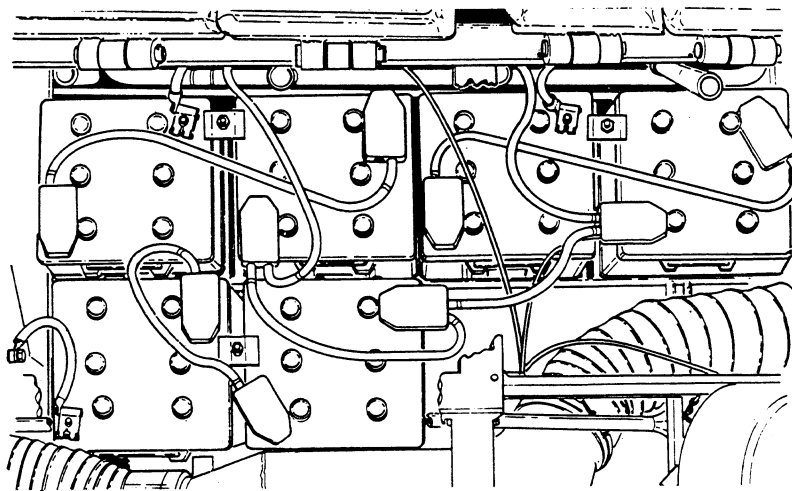

ITEM NO.	INTERVAL	MAN-HOUR	ITEM TO BE CHECKED OR SERVICED	PROCEDURE	EQUIPMENT NOT READY AVAILABLE IF:
49	S		Wiring Harnesses and Cables	a. Inspect for visible damage. b. Replace missing chassis grommets.	
50	S		Lubrication		

NOTE

Lubrication should be performed in sequence and in conjunction with the following checks and services.

- a. Lubricate the vehicle in accordance with WP 0097 00.

51			Final Road Test	a. After all services, inspections, and repairs have been completed, take vehicle on a short road test (approximately 5 miles [8 km]) to be sure that equipment faults have been corrected.	
----	--	--	-----------------	--	--

END OF WORK PACKAGE

UNIT MAINTENANCE
RECOVERY VEHICLE, FULL TRACKED: MEDIUM, M88A1
NSN 2350-00-122-6826, EIC AQA
LUBRICATION INSTRUCTIONS

INITIAL SETUP:**Tools and Special Tools**

Tool kit, general mechanic's (item 59, WP 0490 00)

Materials/Parts

Compound, cleaning (item 9, WP 0489 00)

References

WP 0001 00

WP 0104 00

WP 0245 00

References (cont.)

WP 0266 00

WP 0286 00

WP 0295 00

WP 0297 00

WP 0308 00

WP 0420 00

DA PAM 738-750

TM 9-1005-213-10

TM 9-2350-256-10

General Statements**Scope**

This Work Package provides lubrication instructions, procedures, and information on the authorized lubricants, lubrication intervals, and Army Oil Analysis Program (AOAP) for the M88A1 Medium Recovery Vehicle.

Lubrication Intervals and Interval Symbols

The lubrication instructions found in this Work Package are presented in grouped sequence by location. Intervals (on-condition or hard-time) and related man-hour times are based on normal operation. The man-hour time specified is the time you need to do all the services prescribed for a particular interval. The following symbols are used to indicate how often the lubrication services will be performed.

1. D—Daily
2. Q—Quarterly
3. S—Semiannually
4. A—Annually
5. OC—On-Condition

Table 1. TOTAL MAN-HOURS*

INTERVALS	MAN-HOURS
D	7.3
Q	13.3
S	7.0
A	1.0
OC	5.8
After Fording	24.0

* If AOAP support is not available and hard-time intervals are used, 2 man-hours will be required for each 25-hour period or monthly (whichever comes first); additionally, quarterly labor requirements will increase by 1.3 man-hours, and semiannual requirements will increase by 2.5 man-hours.

Maintenance Level

The maintenance level for all lubrication services in this Work Package is Unit.

Exceptional Operational Requirements

Lubricate more often to compensate for abnormal and extreme conditions. High or low temperatures, prolonged periods of high rate operation, continued operation in sand, dust, or exposure to moisture may quickly destroy the protective qualities of the lubricant. Before performing lubrication checks and services, observe the following:

1. Never use incorrect lubricant or use too much lubricant.
2. Always:
 - a. Clean grease fittings before lubrication
 - b. Use this Work Package as a guide
 - c. Lubricate after fording
 - d. Ensure vehicle is level prior to checking fluid levels.
3. Lubrication after fording operations. As soon as possible after any fording operation in water of 12 inches or more, lubricate all chassis points to cleanse of water of grit. Also lubricate any other points requiring maintenance after fording. If vehicle has been in deep water for a considerable length of time, or was submerged beyond its fording capabilities, the following precautions must be taken as soon as practicable to avoid damage to engine and other vehicle components:
 - a. Perform a complete lubrication service.
 - b. Check APU, main engine and transmission for presence of water or sludge in oil. If found, drain and flush transmission with PE-1 Lubricating Oil, Internal Combustion engine, and drain and flush engines with OE-30 Lubricating Oil, Internal Combustion engine. If PE-1 is not available, flush transmission with OE-10 Lubricating Oil, Internal Combustion engine. Before refilling with clean oil, remove, clean, and install transmission oil filters (see WP 0266 00). Replace engine oil filter elements (see WP 0104 00).
 - c. Check lubricant in hydraulic reservoir and winch gear cases for evidence of water or sludge contamination. If there is evidence of contamination, drain and refill with correct lubricant.
4. For operation of equipment in protracted cold temperatures below -10°F (-23°C). Remove lubricants prescribed in table for temperatures above -10°F (-23°C). Clean parts with cleaning compound (WP 0489 00, item 9) or equivalent. Relubricate with lubricants specified in Table 2, Lubricant Table for M88A1 Medium Recovery Vehicle, for temperatures of 0°F to -65°F (-18°C to -50°C).

Abbreviations

GAA	Grease, Automotive and Artillery (MIL-G-10924)
GO	Lubricating Oil, Gear (MIL-L-2105)
GOS	Lubricating Oil, Gear (MIL-L-10324)
OE-HDO	Lubricating Oil, Internal Combustion Engine (ICE), Tactical Service (MIL-L-2104)
OE-A	Lubricating Oil, ICE, Arctic (MIL-L-46167)
CW	Lubricating Oil, Chain, Wire Rope, Exposed Gear (VV-L-751)

Fittings and Parts Cleaning

WARNING

Solvents can burn easily, give off harmful vapors, and are harmful to skin and clothing. To avoid injury or death, keep away from open flame and use in a well-ventilated area. If solvent gets on skin or clothing, wash immediately with soap and water.

NOTE

Always install dust caps on fittings after lubrication procedures.

Use cleaning compound (item 9, WP 0489 00) to clean parts. Dotted arrow points indicate lubrication on both sides of the equipment.

Do not lubricate personnel heater motor, ventilating blower motor, or auxiliary power unit air cleaner.

Lubricate at assembly by field or depot maintenance units starter, commander's cupola, fuel injector drive coupling, and driver's, rigger's, and mechanic's hatch mechanisms.

Corrosion Control

Follow corrosion control procedures as indicated in WP 0001 00.

Oil Filter Statement

Oil filters shall be serviced/cleaned/changed as applicable, when:

1. They are known to be contaminated or clogged,
2. Service is recommended by AOAP laboratory analysis, or
3. At prescribed hard-time intervals.

AOAP Sampling Interval Statement

On-condition (OC) oil sample intervals shall be applied unless changed by the AOAP laboratory. Change the hard-time interval if your lubricants are contaminated or if you are operating the equipment under adverse conditions, including longer-than-usual operating hours. The hard-time interval may be extended during periods of low activity. If extended, adequate preservation precautions must be taken. Hard-time intervals will be applied in the event AOAP laboratory support is not available.

Warranty Hard-Time Statement

For equipment under manufacturer's warranty, hard-time oil service intervals shall be followed. Intervals shall be shortened if lubricants are known to be contaminated or if operation is under adverse conditions (such as longer than usual operating hours, extended idling periods, or extreme dust).

Lubrication

Table 2. Lubricant Table for M88A1 Medium Recovery Vehicle

Lubricants		Capacities	Expected Temperatures For Arctic Operation, Refer to FM 9-207			Interval
			Above 15°F (Above -9°C)	+40°F to -10°F (+4°C to -23°C)	0°F to -65°F (-18°C to -54°C)	
GAA MIL-G-10924	GREASE, Automotive and Artillery <u>All grease points</u>	As Required	All Temperatures			
GO MIL-L-2105 or GOS MIL-L-10324	LUBRICATING OIL, Gear, Multipurpose LUBRICATING OIL, Gear, Subzero <u>Hoist Winch Gear Case</u> <u>Main Winch Gear Case</u>	3 gal (11.36 L) 11 gal (41.64 L)	GO 90	GO 90	GOS	
OE/HDO MIL-L-2104 or OEA MIL-L-46167	LUBRICATING OIL, Internal Combustion Engine, Tactical Service LUBRICATING OIL, Internal Combustion Engine, Arctic <u>Boom Stayline Cables</u> <u>Hoist Winch Cable</u> <u>Mechanical Transmission</u> <u>Hydraulic Reservoir</u>	As Required 1 gal (3.79 L) 95 gal (359.58 L)	OE/HDO-10	OE/HDO-10	OEA	
CW VV-L-751	LUBRICATING OIL, Chain, Wire Rope, Exposed Gear <u>Hoist Winch Cable</u>	As Required	CW-IIC	CW-IIB	CW-IIA	

SERVICE FROM OUTSIDE OF VEHICLE

LUBRICANT • INTERVAL

INTERVAL • LUBRICANT

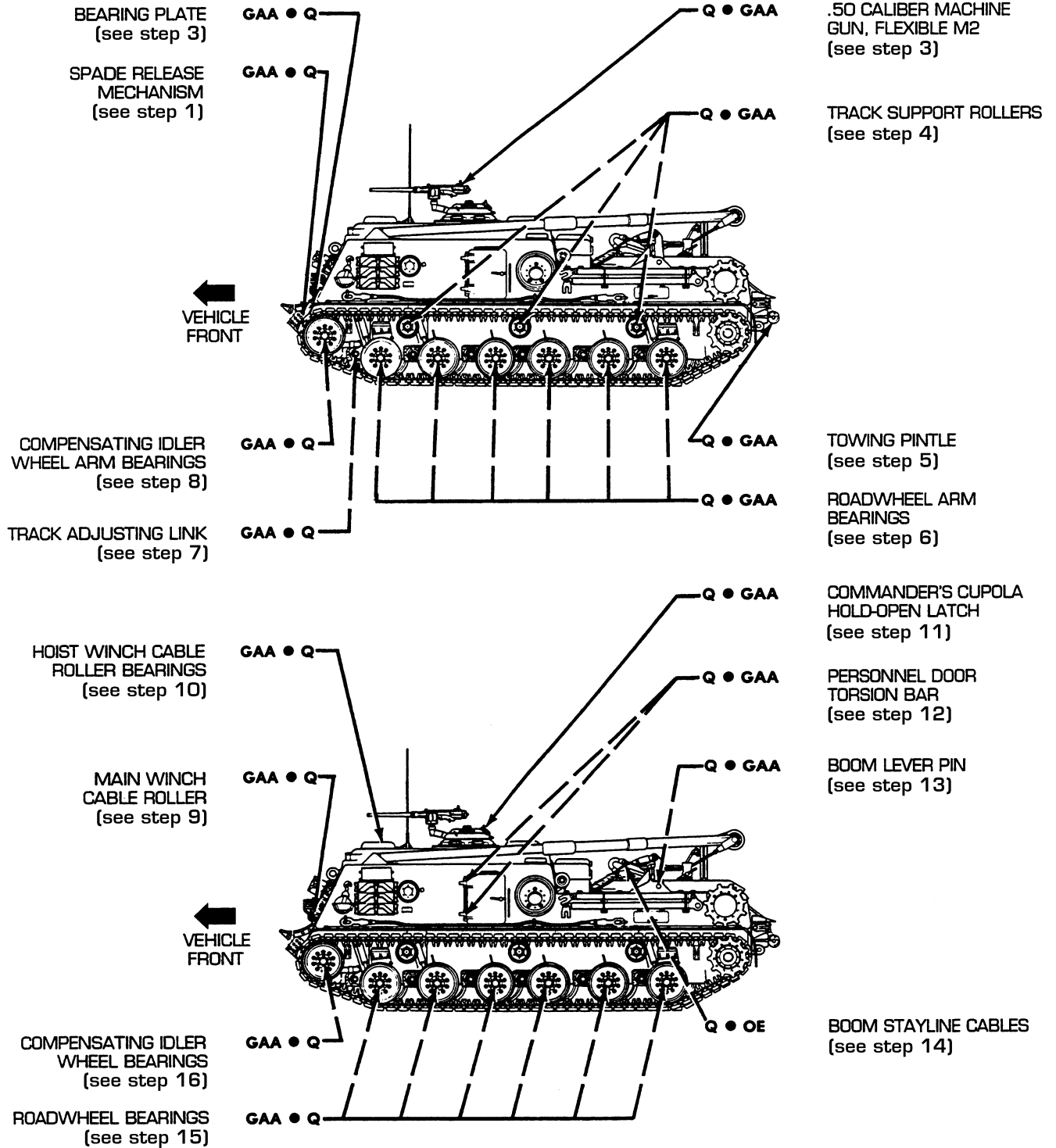

1. Spade release mechanism. Clean and coat exposed part of spade lockpin (1) with GAA. Use a hand grease gun to pump grease into fitting (2) on right side of pin housing.
2. Bearing plate. Clean and coat plate (3) with GAA.

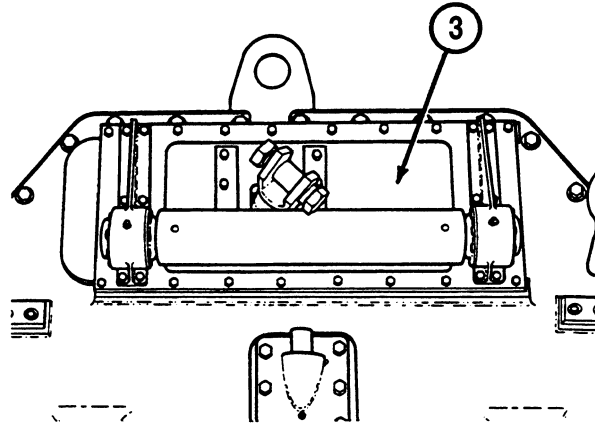
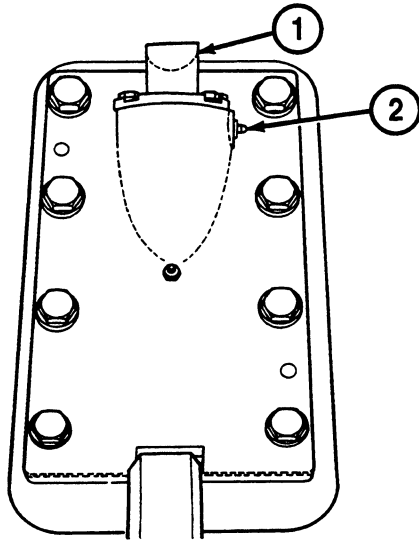

3. Flexible M2 .50 caliber machine gun. Lubricate machine gun (4) with GAA (refer to TM 9-1005-213-10).
4. Track support rollers. Lubricate with GAA through three fittings (5) on each wheel.

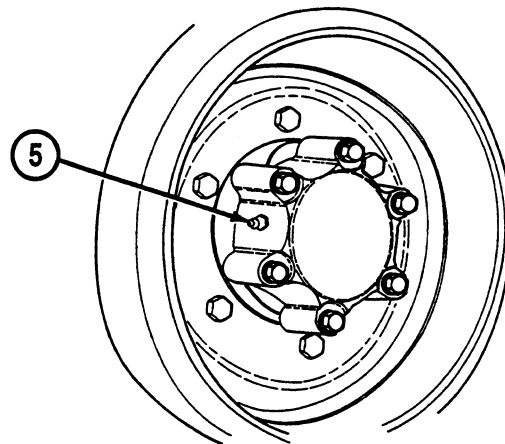
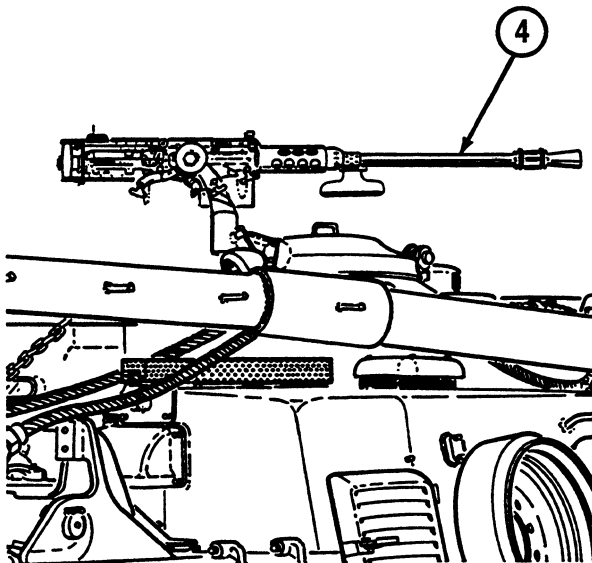

5. Towing pintle. Lubricate with GAA through three fittings (6).
6. Roadwheel arm bearings. Lubricate with GAA through three fittings (7) on each roadwheel arm.

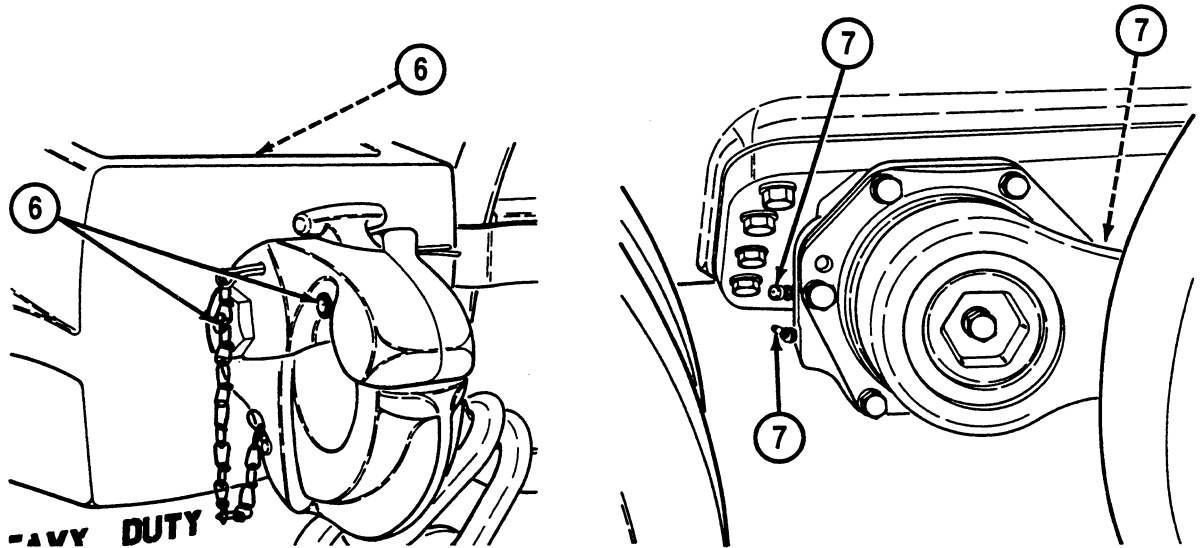

7. Track adjusting link. Lubricate with GAA through fitting (8).
8. Compensating idler wheel arm bearings. Lubricate with GAA through fittings (9).

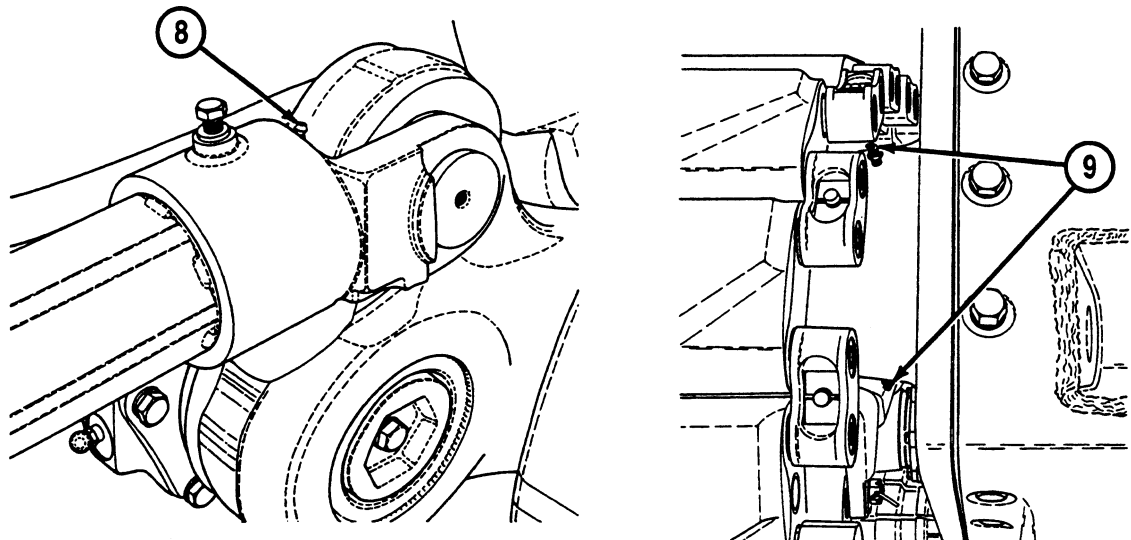

9. Main winch cable roller. Lubricate with GAA through two fittings (10).
10. Hoist winch cable roller bearings. Open hoist winch cable access cover (11) and lubricate with GAA through four fittings (12). Close access cover.

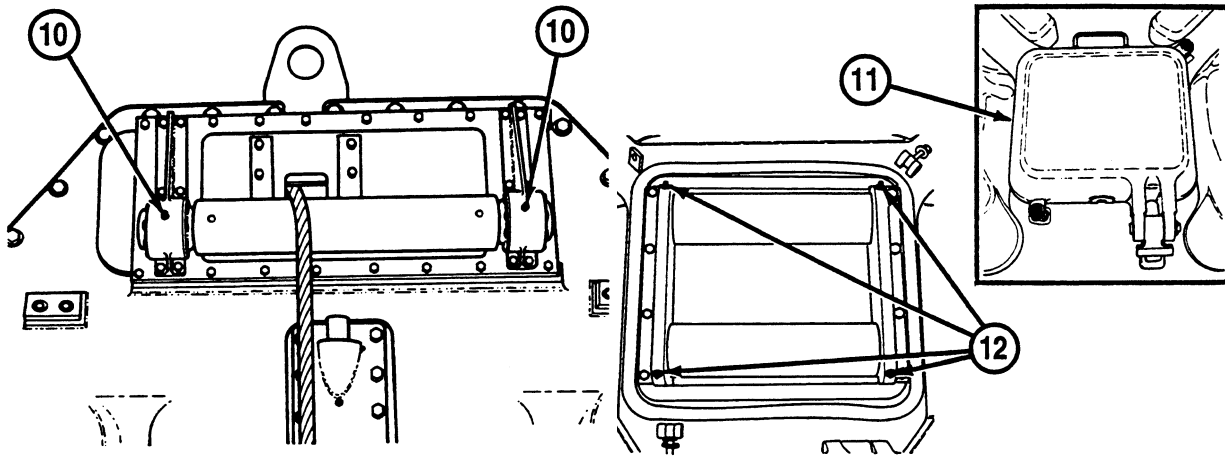

11. Commander's cupola hold-open latch. Lubricate with GAA through fitting (13) at end of pivot pin.
12. Personnel door torsion bar.

NOTE

There are two fittings on each door.

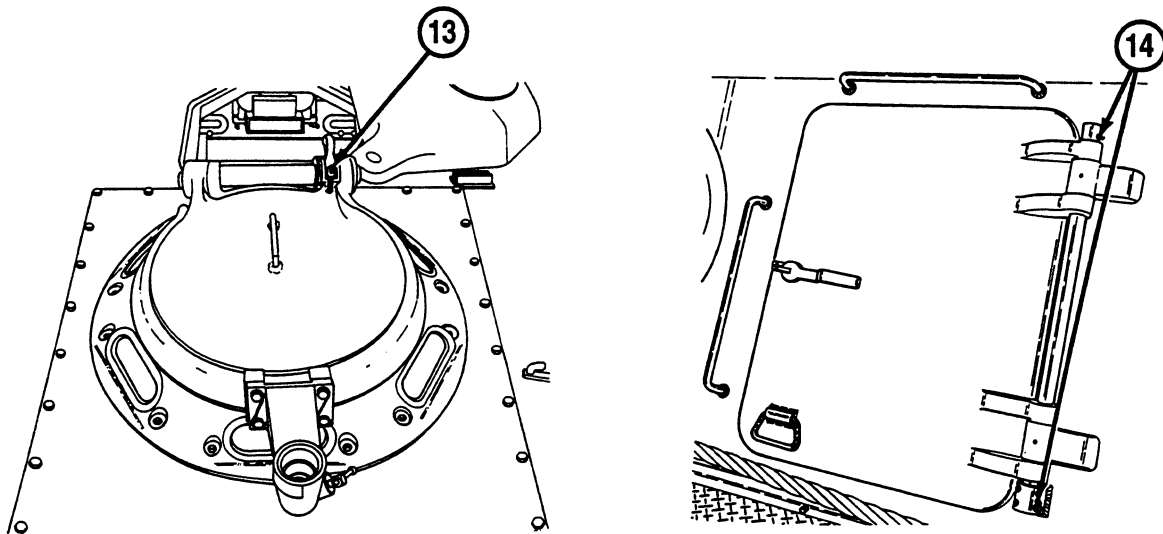

Lubricate with GAA through four fittings (14).

13. Boom lever pin. Lubricate with GAA through fitting (15).

NOTE

There is one fitting at each pin.

14. Boom stayline cables.

WARNING

Never handle cable with bare hands. Broken or frayed wire strands can cause severe cuts. Always wear protective (leather) gloves when handling cable.

Clean and oil cable (16) with OE. If cable has not been used within a six-month period, clean entire cable and brush soak it with OE. Wipe cable to remove excess oil. Coat cable with CW.

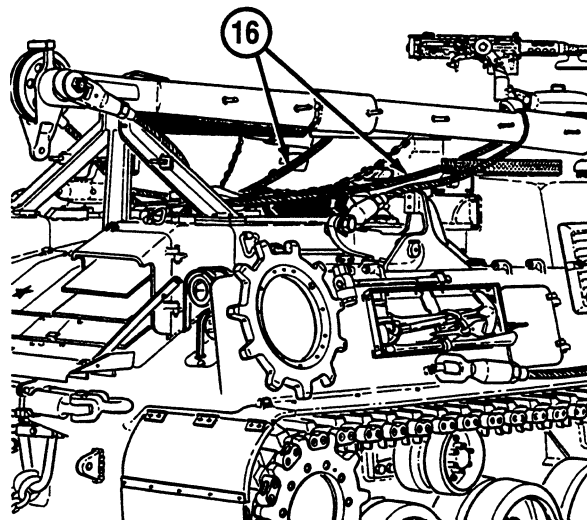
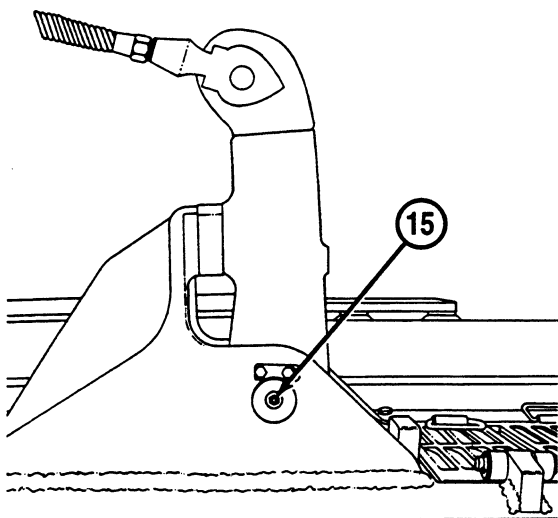

15. Roadwheel bearings. Lubricate with GAA through six fittings (17) at each side.

16. Compensating idler wheel bearings. If vehicle is without grease fitting (18), remove plug (19) and insert fitting. Lubricate with GAA through fitting. Remove fitting and install plug.

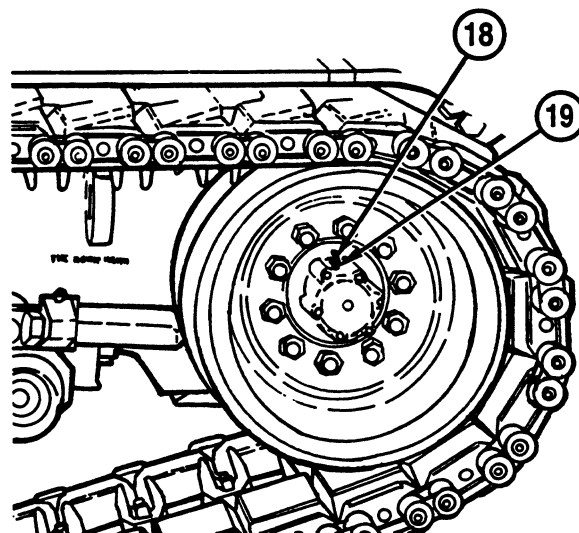
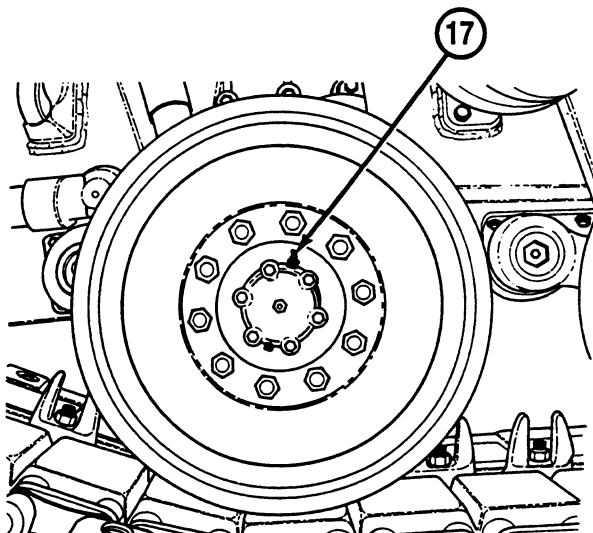

SERVICE FROM CREW COMPARTMENT

LUBRICANT • INTERVAL

INTERVAL • LUBRICANT

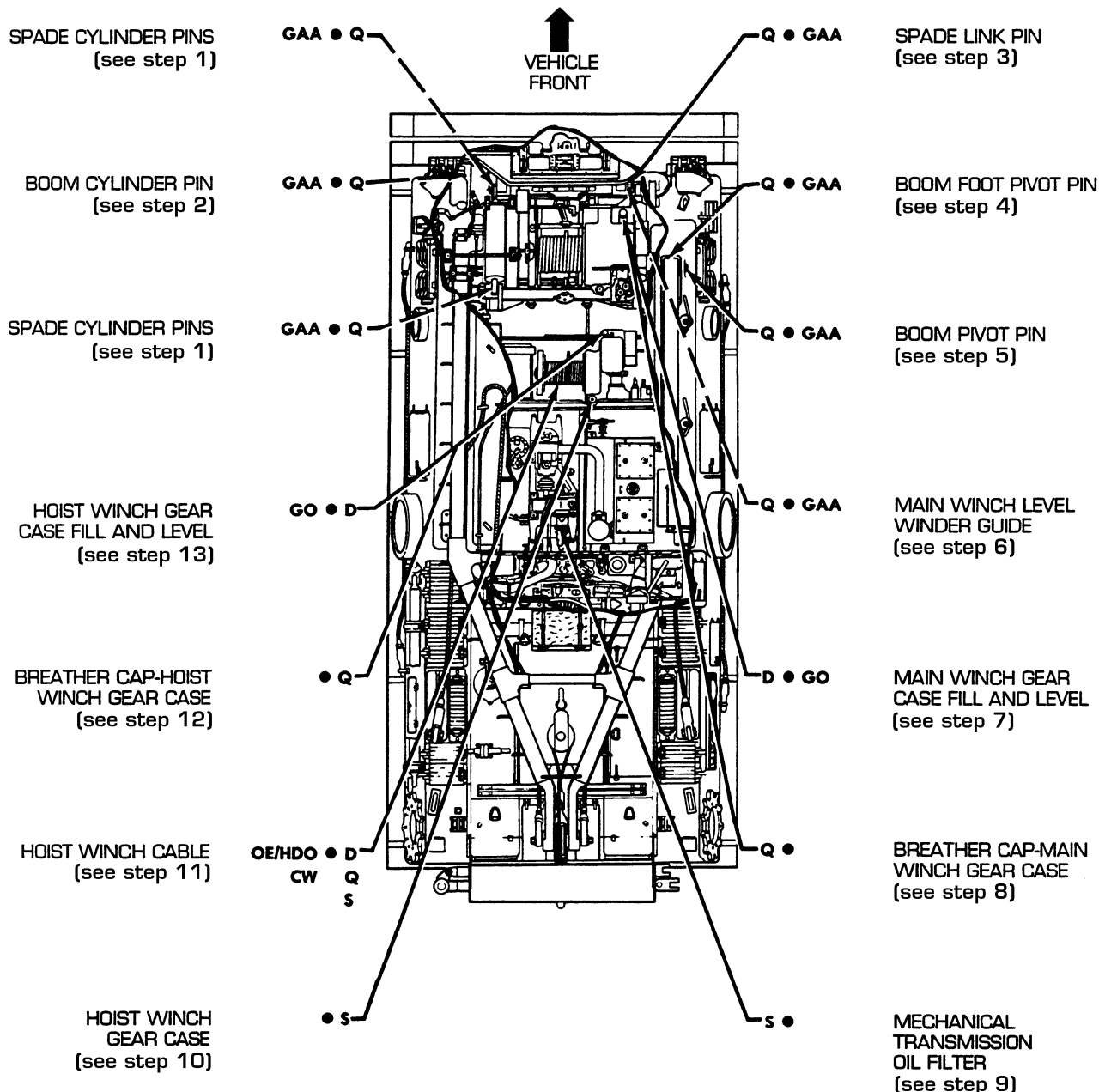

LUBRICANT • INTERVAL

INTERVAL • LUBRICANT

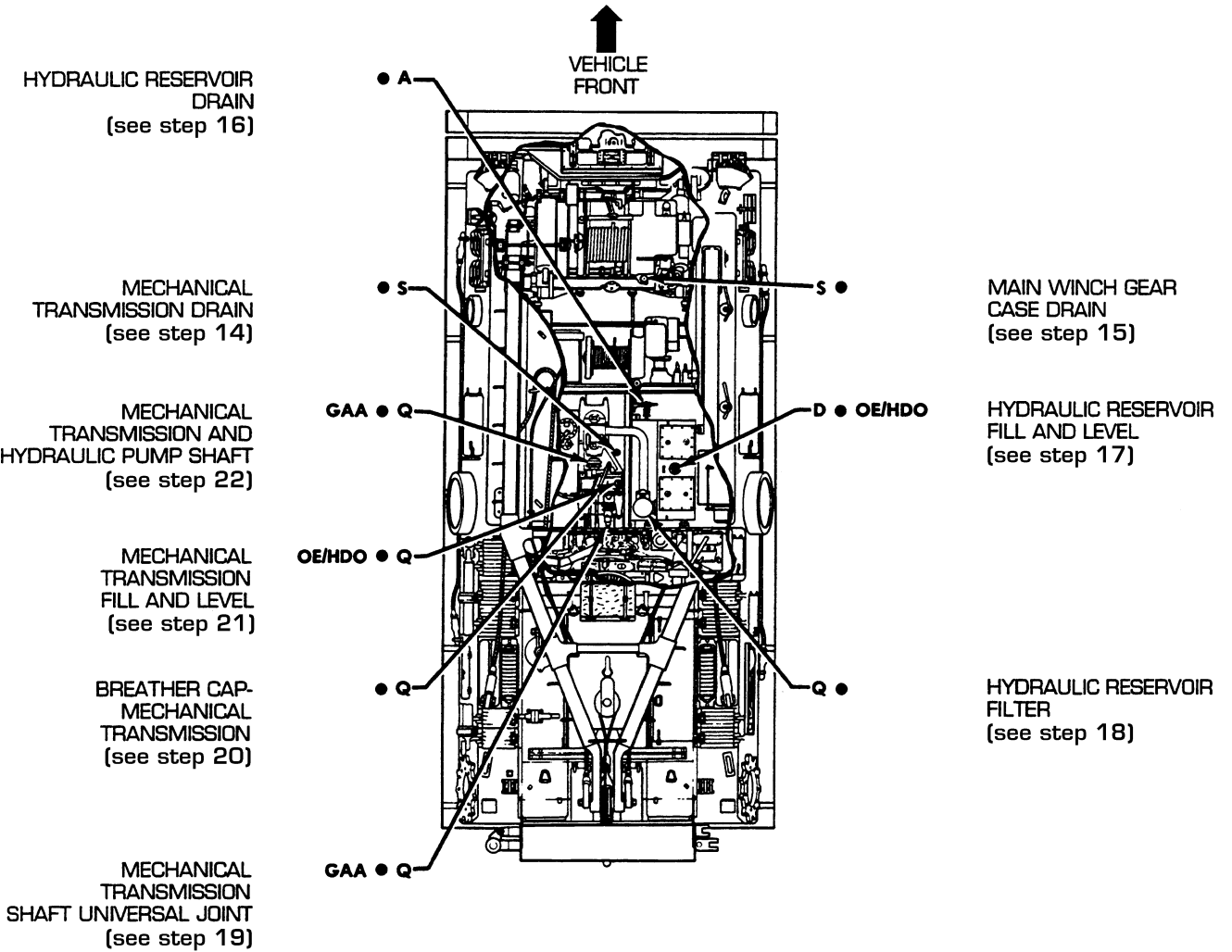

LUBRICANT • INTERVAL

INTERVAL • LUBRICANT

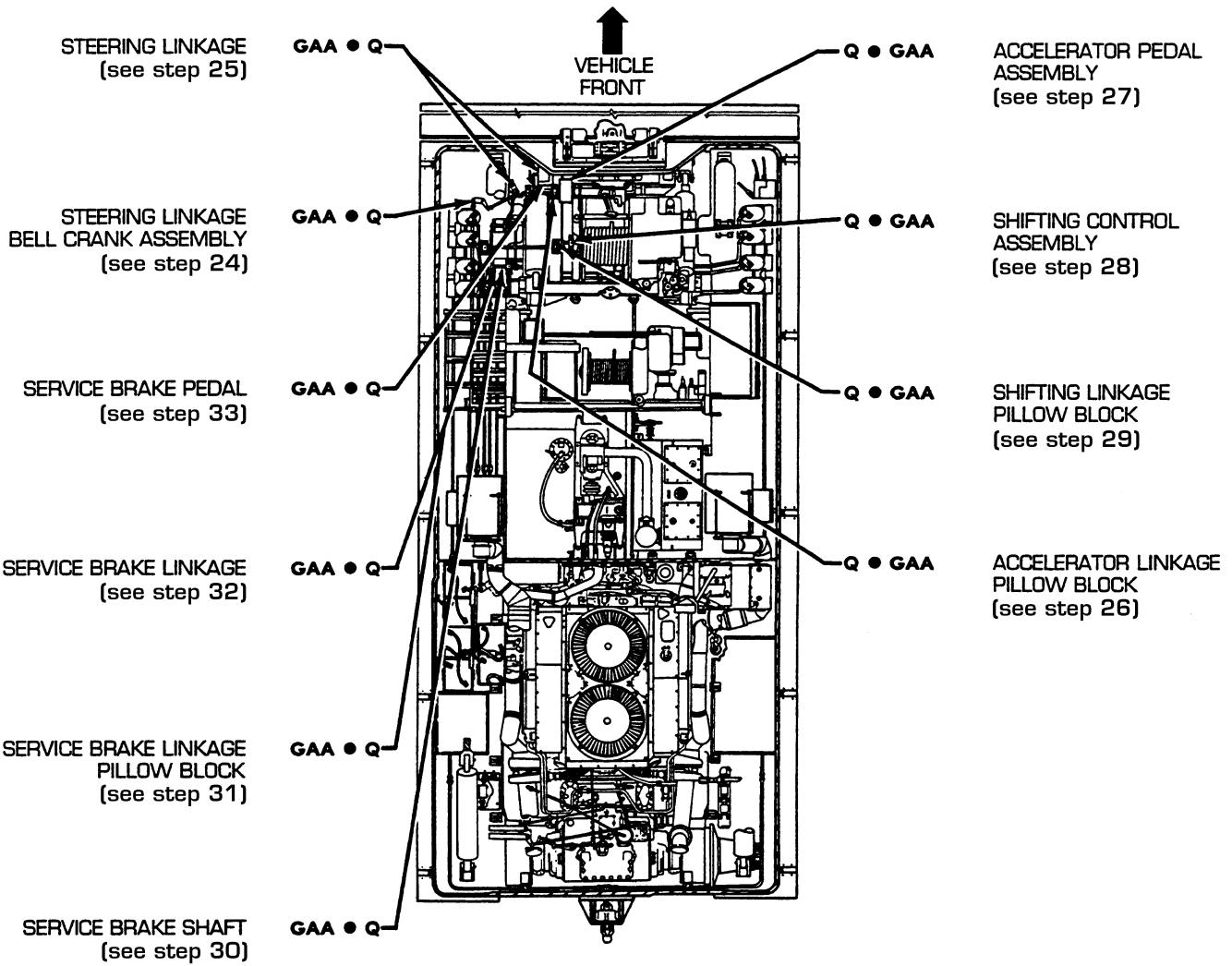
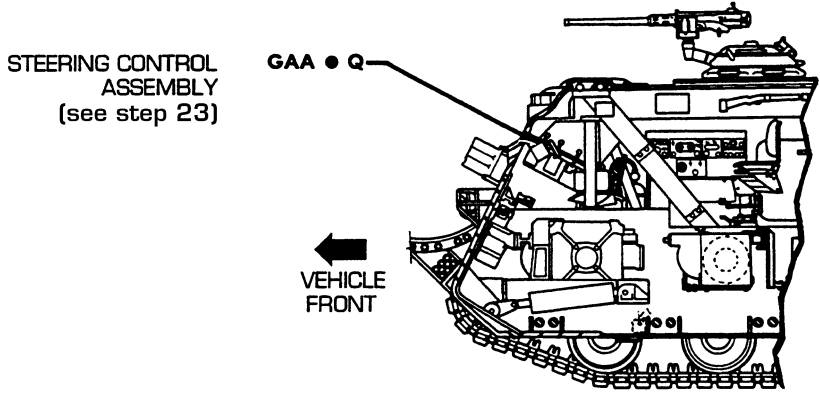

1. Spade cylinder pins.

- a. Front left pin. Lubricate with GAA through fitting (1) at front of each cylinder and fitting at rear of each cylinder.
- b. Front right pin.

- (1) Remove subfloor plate (see WP 0286 00).
- (2) Lubricate with GAA through fitting (2) at front of each cylinder and fitting at rear of each cylinder.
- (3) Install subfloor plate (see WP 0286 00).

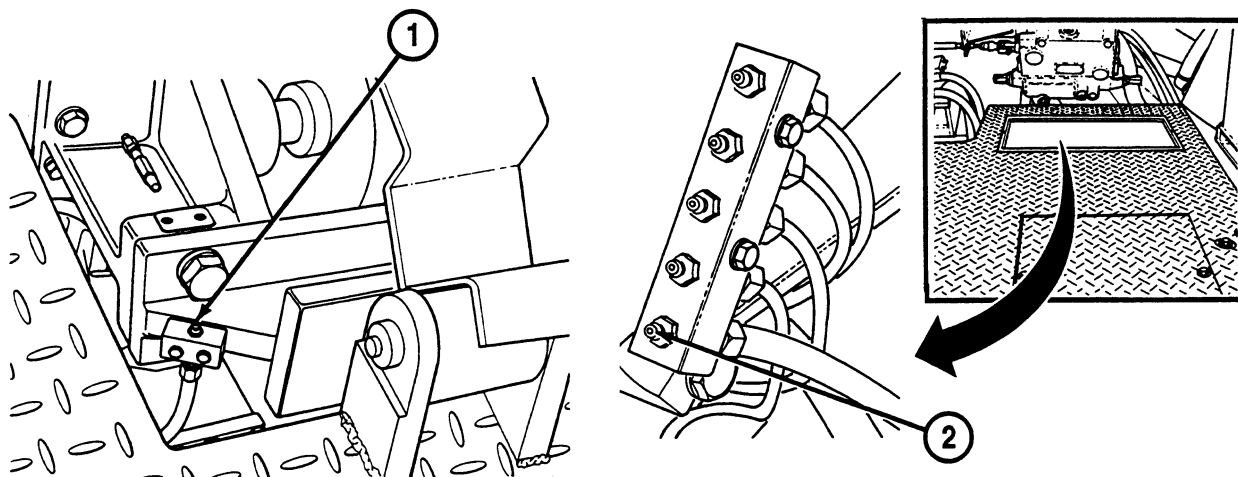

c. Rear left pin.

- (1) Open access door (3).
- (2) Lubricate with GAA through fitting (4) at front of each cylinder and fitting at rear of each cylinder.
- (3) Close access door (3).

d. Rear right pin.

- (1) Remove subfloor plate (see WP 0308 00).
- (2) Lubricate with GAA through fitting (5) at front of each cylinder and fitting at rear of each cylinder.
- (3) Install subfloor plate (see WP 0308 00).

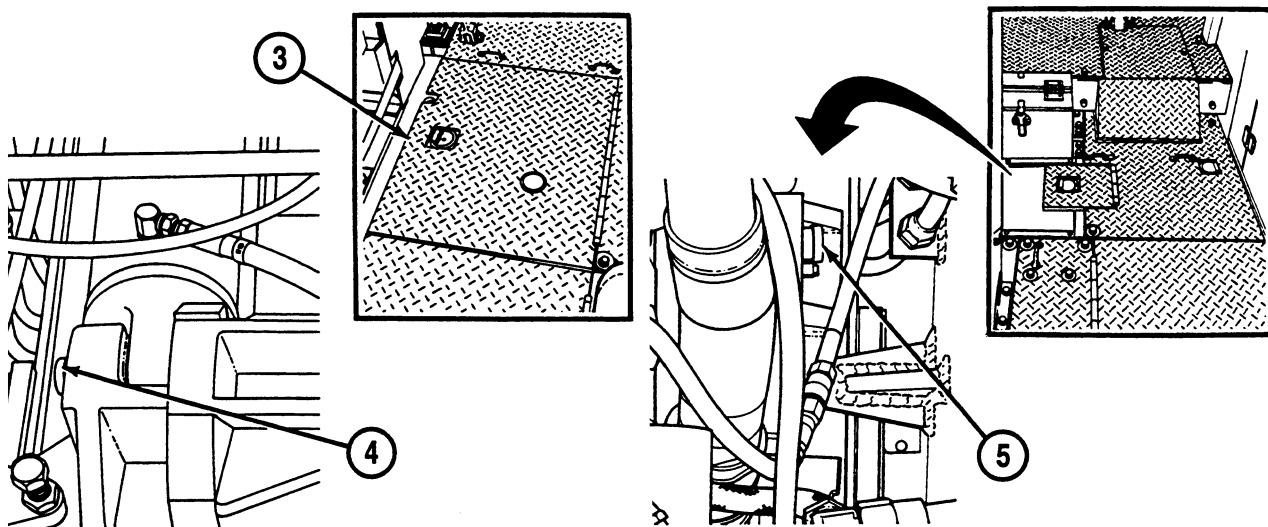

2. Boom cylinder pin. Lubricate with GAA through fitting (6).
3. Spade link pin.
 - a. Remove subfloor plate (see WP 0286 00).
 - b. Lubricate with GAA through fittings (7).
 - c. Install subfloor plate (see WP 0286 00).

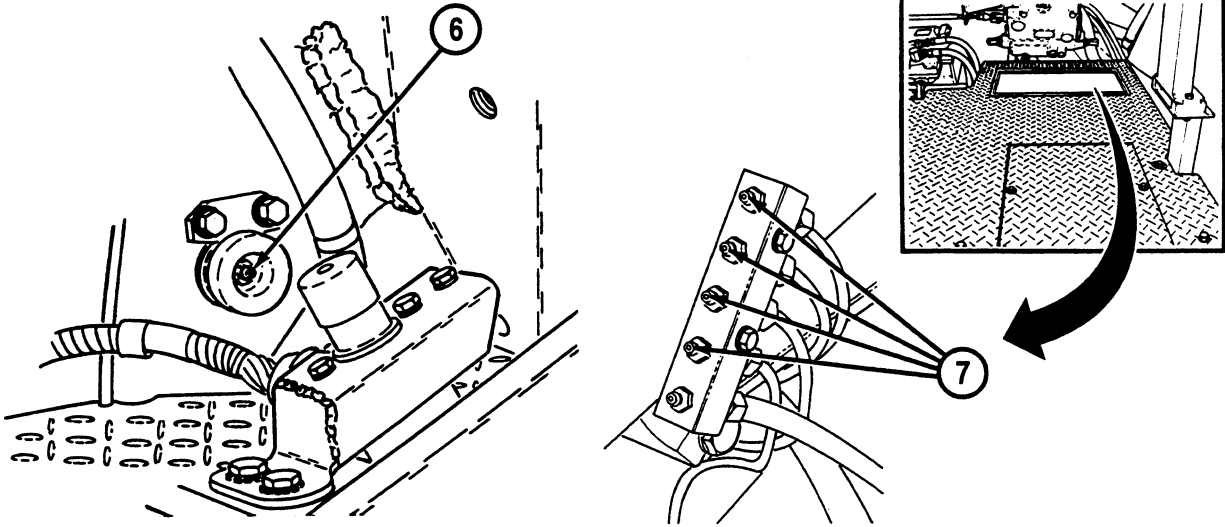

4. Boom foot pivot pin.

NOTE

There is one fitting on each side of vehicle.

Raise boom and lubricate with GAA through fitting (8). Lower boom.

5. Boom pivot pin.

NOTE

There is one fitting on each side of vehicle.

Lubricate with GAA through fitting (9).

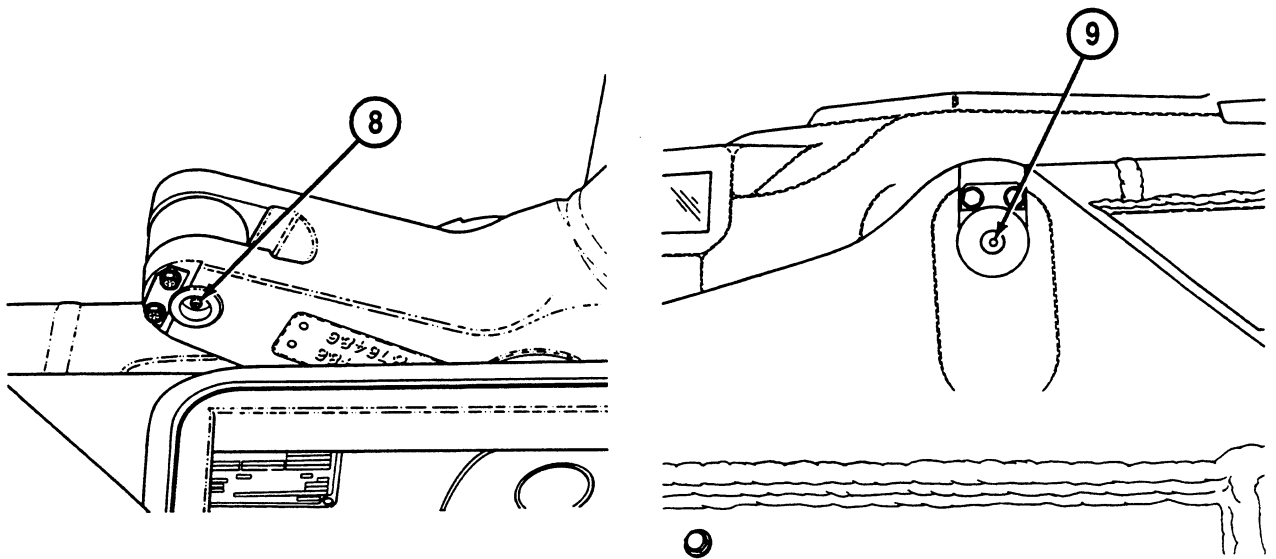

6. Main winch level winder guide. Lubricate with GAA through two fittings (10).

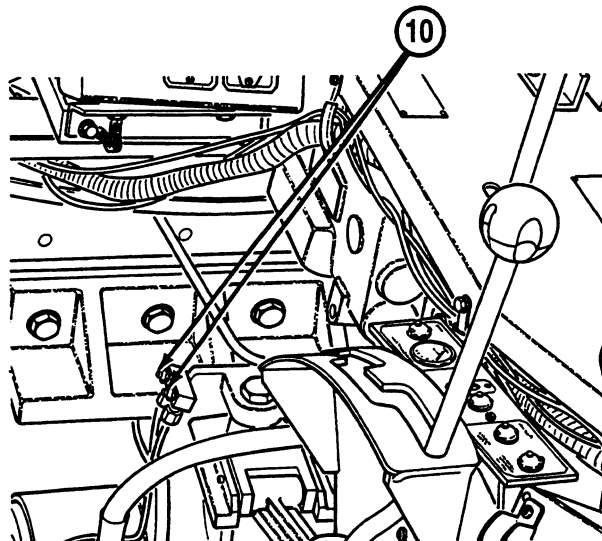

7. Main winch gear case fill and level.
 - a. Remove subfloor plate (see WP 0286 00).
 - b. Before operation, remove breather cap (11) and bayonet gage (12). Check to see that oil level is to the FULL mark on gage. If level is below FULL mark, add oil (see Table 2) until oil level rises to FULL mark.
 - c. Install bayonet gage (12) and cap (11).
 - d. Install subfloor plate (see WP 0286 00).
8. Breather cap-main winch gear case.
 - a. Remove subfloor plate (see WP 0286 00).
 - b. Remove breather cap (11) and clean it with cleaning compound (item 9, WP 0489).
 - c. Install breather cap (11).
 - d. Install subfloor plate (see WP 0286 00).
9. Mechanical transmission oil filter.
 - a. Remove subfloor plate (see WP 0297 00).
 - b. Remove filter (13) from mechanical transmission.
 - c. Clean filter (13) with cleaning compound (item 9, WP 0489 00).
 - d. Install filter (13).
 - e. Install subfloor plate (see WP 0297 00).

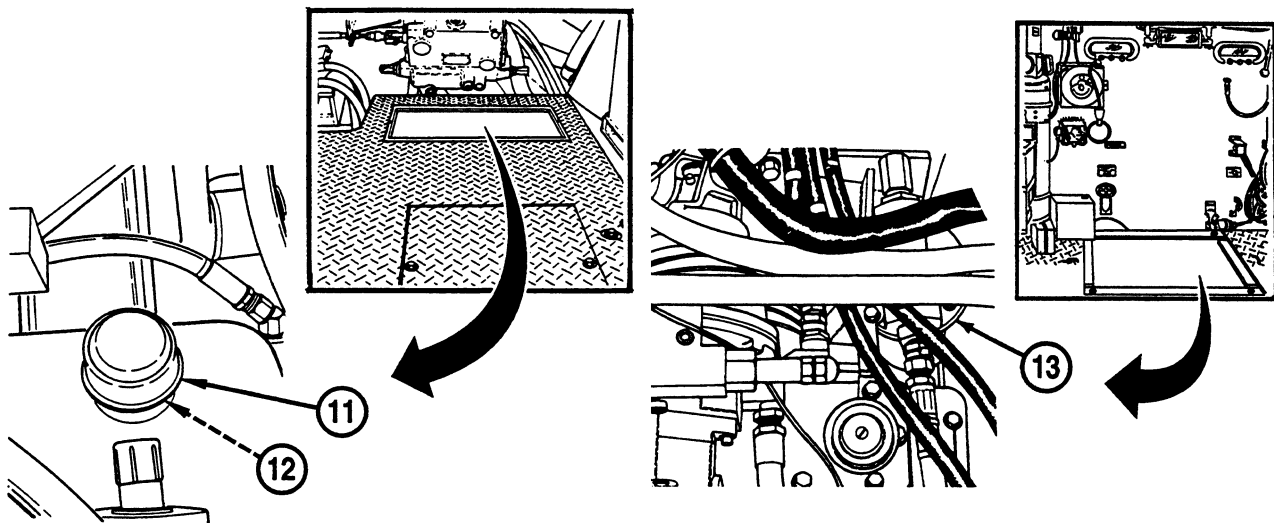

10. Hoist winch gear case drain.

NOTE

Drain oil from hoist winch gear case when oil is at operating temperature.

- a. Open access door (14).
- b. Place a suitable receiving container of three-gallon capacity under oil outlet. Open hull drain valves (15); then open hoist winch drain valve.
- c. After oil has drained, close hoist winch valve; then close hull drain valve (15).

- d. Refill hoist winch gear case with appropriate weight of oil (see Table 2).
- e. Close access door (14).

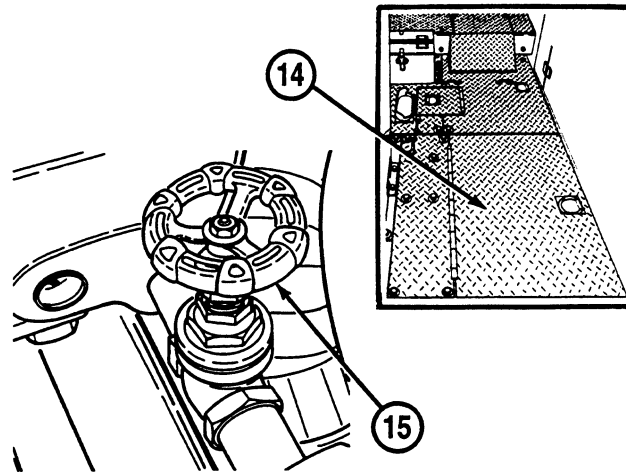

11. Hoist winch cable.

WARNING

Never handle cable with bare hands. Broken or frayed wire strands can cause severe cuts. Always wear protective (leather) gloves when handling cable.

- a. Daily. If winch has been used, clean cable (16) and oil with OE.
- b. Quarterly. Unwind entire cable (16) and clean it; then oil cable with OE.
- c. Semiannually. If winch has not been used since last semiannual service, unwind and clean entire cable (16). Brush soak with OE and wipe to remove excess oil. Coat and drain cable with CW before rewinding cable.

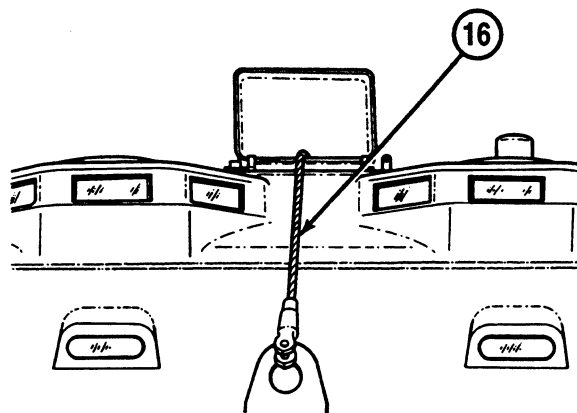

12. Breather cap-hoist winch gear case.
 - a. Open access door (17).
 - b. Remove breather cap (18) and clean it with cleaning compound (item 9, WP 0489).
 - c. Install breather cap (18).
 - d. Close access door (17).
13. Hoist winch gear case fill and level.
 - a. Open access door (17).
 - b. Remove bayonet gage (19) and check to see that oil level is not below ADD mark on the gage rod. If necessary, add GO (see Table 2) up to FULL mark.
 - c. Close access door (17).

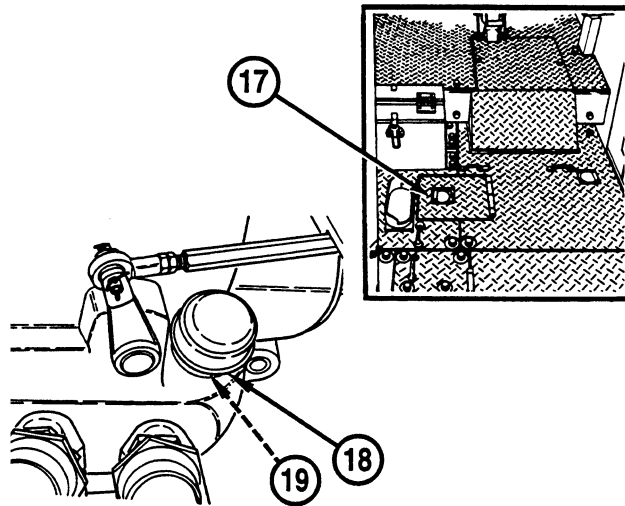

14. Mechanical transmission drain.

- a. Remove subfloor plate (see WP 0297 00).
- b. Drain oil from mechanical transmission semiannually or every 1500 miles (2414 kilometers). Start main engine to operate transmission until warm. Shut down engine and open hull drain valve (20).
- c. Open mechanical transmission and oil cooler drain valve. After oil has drained, close mechanical transmission and oil cooler drain valve, and close hull drain valves.
- d. Fill mechanical transmission (see step 21).
- e. Install subfloor plate (see WP 0297 00).

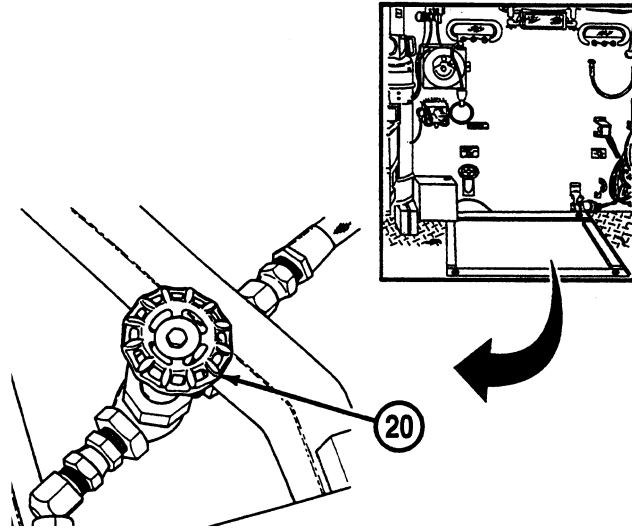

15. Main winch gear case drain.
 - a. Open access cover (17).
 - b. Operate main winch to warm oil to operating temperature. Shut down all systems.
 - c. Open hull drain valves (21) and open main winch drain valve. After draining, close main winch drain valve and hull drain valves.
 - d. Refill main winch (see step 7) with oil (see Table 2).
 - e. Close access cover (17).
16. Hydraulic reservoir drain.
 - a. Open access door (14).
 - b. Before draining hydraulic system, warm hydraulic fluid by idling main engine at 675 rpm for 5 minutes with main hydraulic pump engaged and all hydraulic levers in neutral.
 - c. Shut down engine and open hull drain valves. Open hydraulic reservoir drain valve (22). After reservoir is drained, close hydraulic reservoir drain valve and hull drain valves.
 - d. Refill reservoir (see step 17).

NOTE

Each time hydraulic oil is changed, hydraulic reservoir filter should be serviced (see step 18).

- e. Close access door (14).

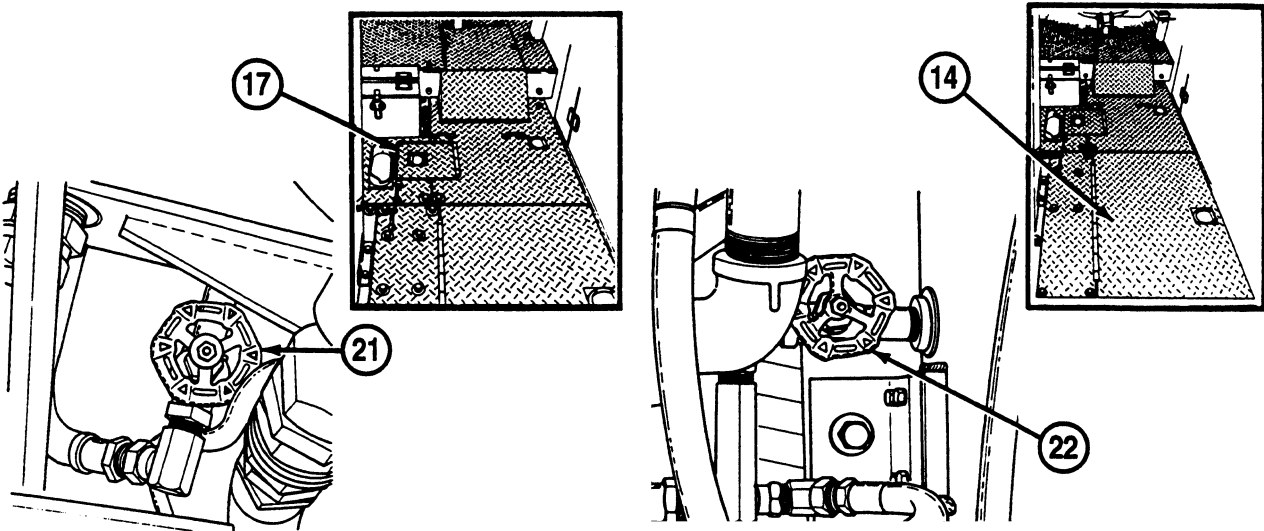

17. Hydraulic reservoir fill and level.

- a. Remove subfloor plate (see WP 0295 00).
- b. Before operation, remove bayonet gage (23) and check that oil level in the reservoir measures up to the FULL mark. If necessary, remove fill cap (24) and add oil (see Table 2) until oil level reaches FULL on bayonet gage.
- c. Install bayonet gage (23) and fill cap (24).
- d. Operate hydraulic system until hydraulic oil reaches operating temperature. Shut down all systems and check oil level again. Add oil, if necessary.
- e. Install subfloor plate (see WP 0295 00).

18. Hydraulic reservoir filter.

- a. Remove subfloor plate under rigger's seat (see WP 0297 00).
- b. Remove eight screws (25) in filter cover (26), and remove cover.
- c. Remove filter element (see WP 0420 00) and clean it with cleaning compound (item 9, WP 0489); then dry with low-pressure compressed air.
- d. Remove two preformed gaskets from between cover and filter element. Discard used gaskets and install new gaskets (see WP 0420 00).
- e. Install filter element (see WP 0420 00), filter cover (26), and eight attaching screws (25).
- f. Operate hydraulic system and check for leaks. Shut down system and install subfloor plate (see WP 0297 00).

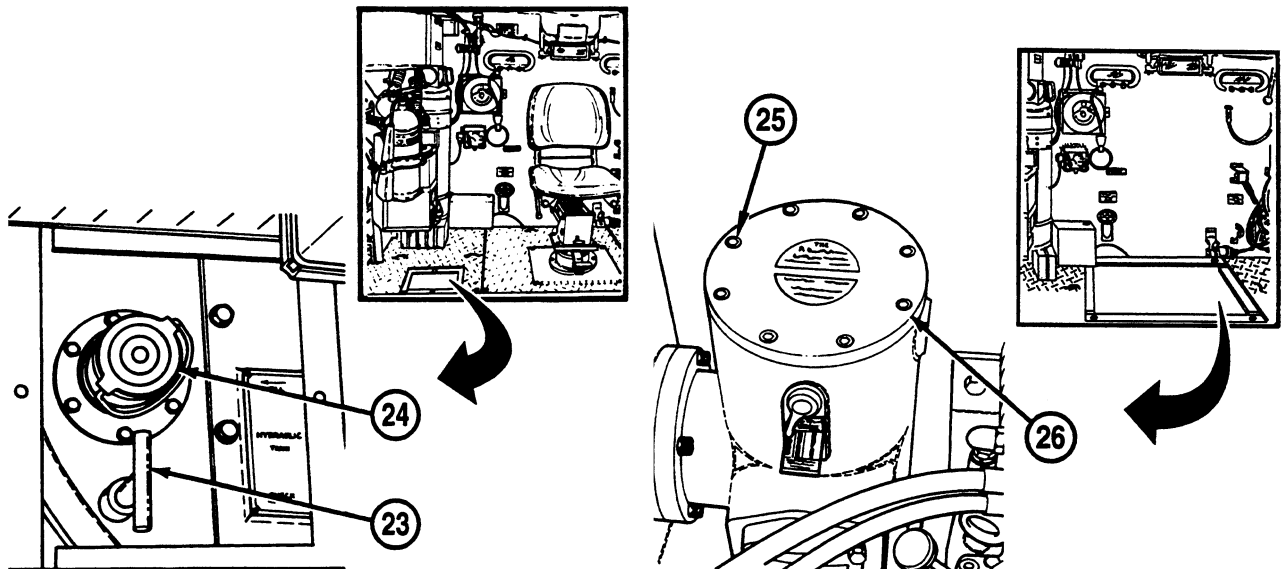

19. Mechanical transmission shaft universal joint.
 - a. Remove subfloor plate (see WP 0297 00).
 - b. Loosen clamp (27) and pull boot (28) out of way.
 - c. Rotate joint (29) as necessary to obtain access to two grease fittings (30).
 - d. Lubricate with GAA through fittings (30).
 - e. Reposition boot and install subfloor plate (see WP 0297 00).

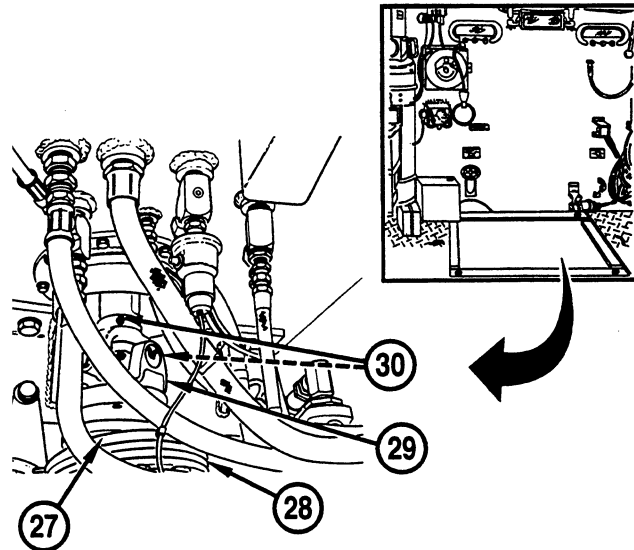

20. Breather cap-mechanical transmission.
 - a. Remove subfloor plate (see WP 0297 00).
 - b. Remove breather cap (31) and clean it with cleaning compound (item 9, WP 0489 00).
 - c. Install cap (31).
 - d. Install subfloor plate (see WP 0297 00).
21. Mechanical transmission fill and level.
 - a. Remove subfloor plate (see WP 0297 00).
 - b. Before operation, remove cap (31) and bayonet gage (32).
 - c. Check that oil level is to the FULL mark on gage. If necessary, fill mechanical transmission with oil (see Table 2) until FULL mark is reached.
 - d. Start main engine to operate mechanical transmission for a few minutes. Stop engine and check oil level again. Add oil, if necessary.

- e. Install subfloor plate (see WP 0297 00).

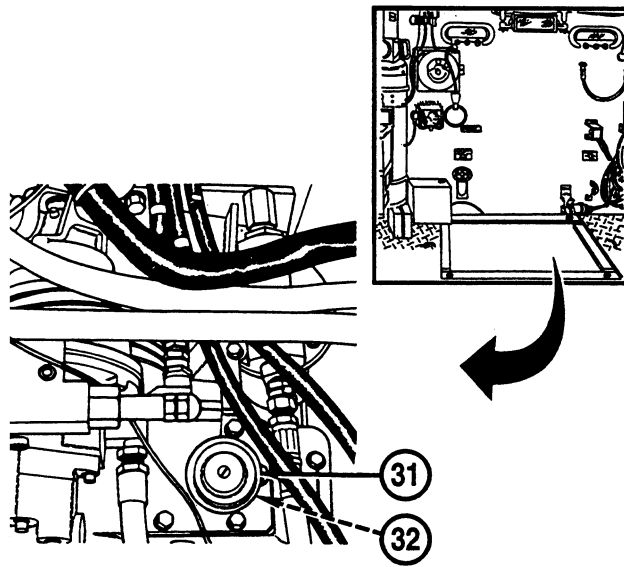

22. Mechanical transmission and hydraulic pump shaft coupling.

- a. Remove subfloor plate (see WP 0297 00).
- b. Lubricate with GAA through two fillings (33).
- c. Install subfloor plate (see WP 0297 00).

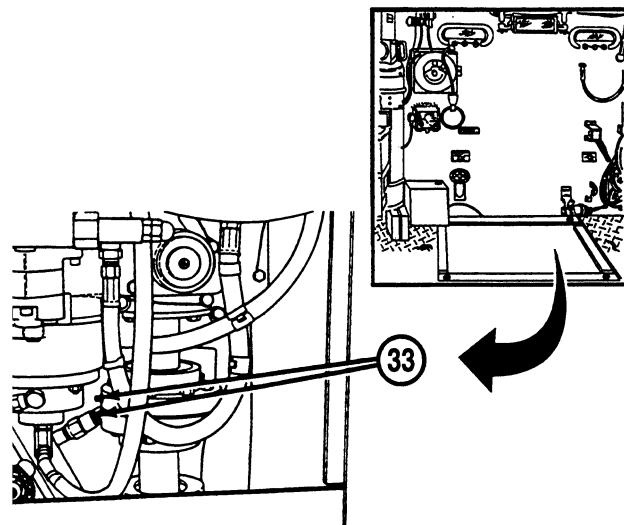

- 23. Steering control assembly. Lubricate with GAA through two fittings (34).
- 24. Steering linkage bell crank assembly. Lubricate with GAA through fitting (35).

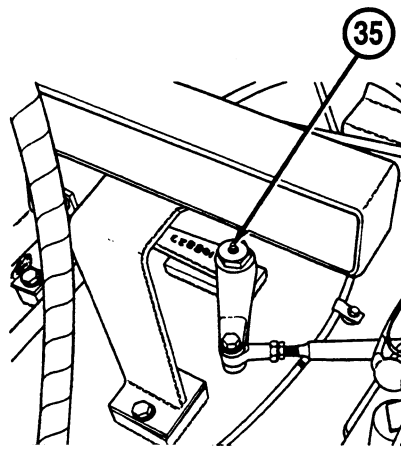
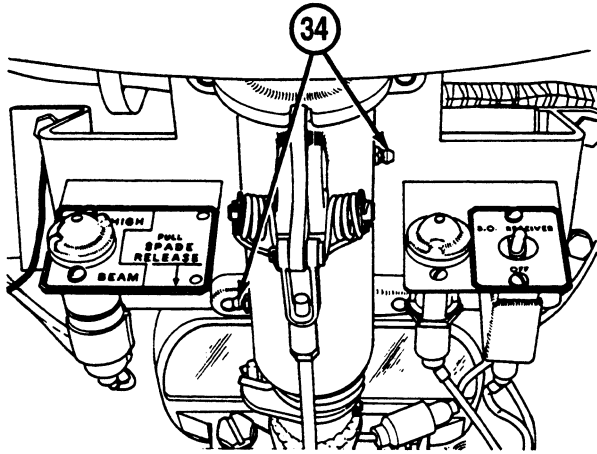

- 25. Steering linkage. Lubricate with GAA through two fittings (36).
- 26. Accelerator linkage pillow block. Lubricate with GAA through two fittings (37).

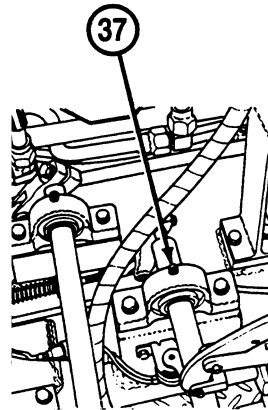
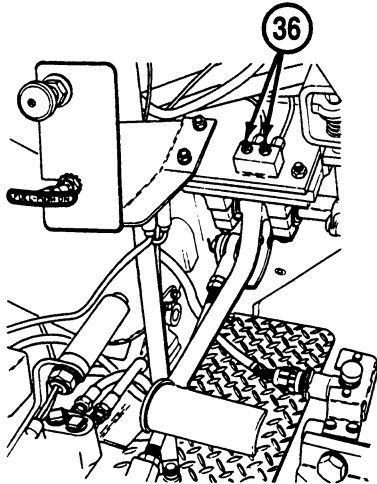

LEFT SIDE

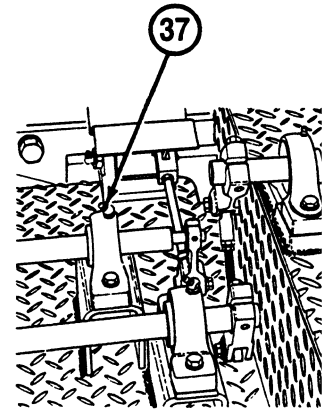

RIGHT SIDE

27. Accelerator pedal assembly. Lubricate with GAA through fitting (38).

28. Shifting control assembly. Lubricate with GAA through two fittings (39).

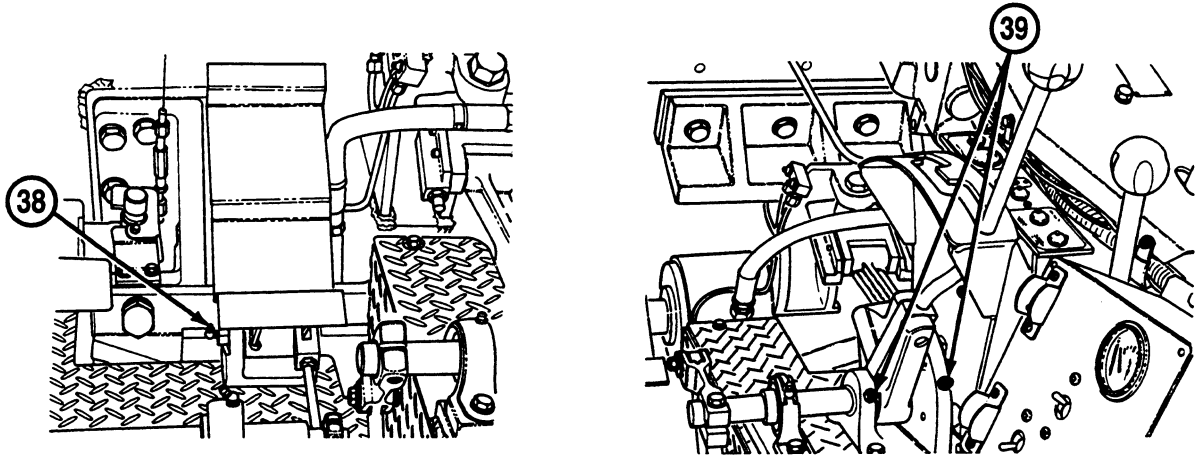

29. Shifting linkage pillow block. Lubricate with GAA through three fittings (40).

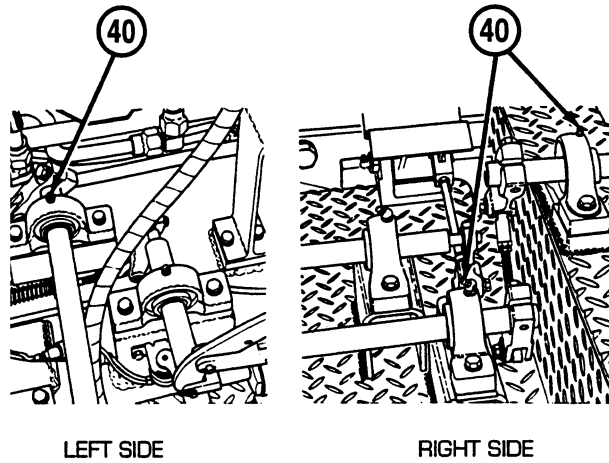

30. Service brake shaft.

NOTE

There is one fitting at each end of shaft.

Lubricate with GAA through two fittings (41).

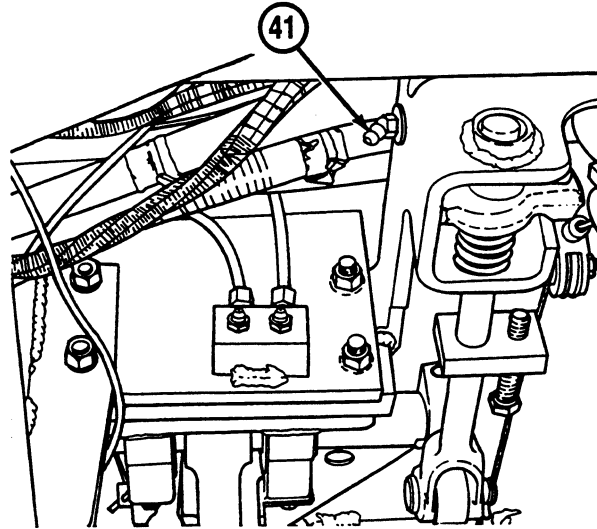

31. Service brake linkage pillow block. Lubricate with GAA through two fittings (42).

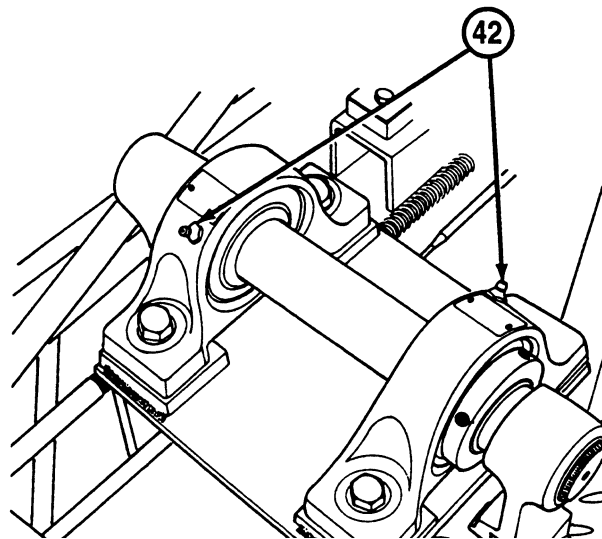

32. Service brake linkage. Lubricate with GAA through fitting (43).

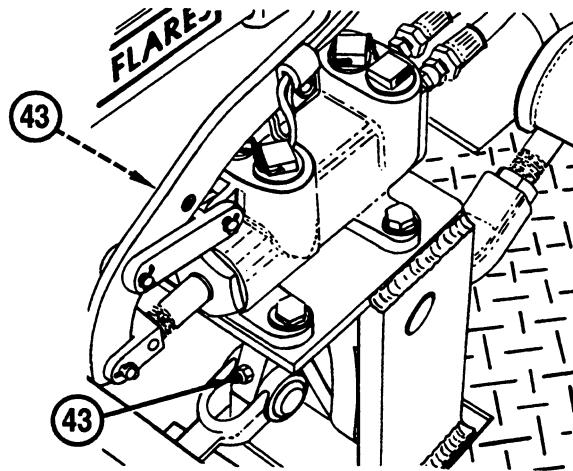

33. Service brake pedal. Lubricate with GAA through fitting (44).

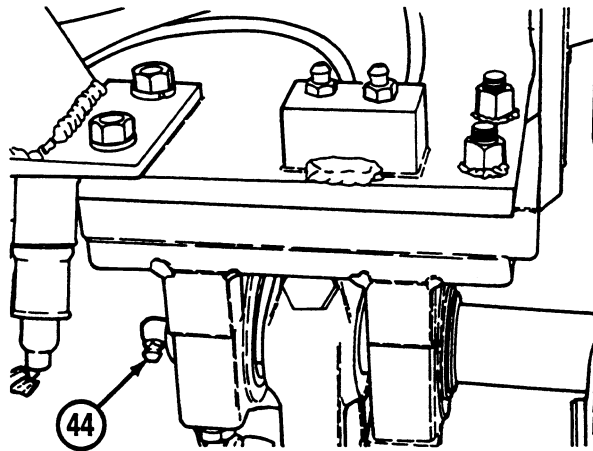

SERVICE FROM ENGINE COMPARTMENT

LUBRICANT • INTERVAL

INTERVAL • LUBRICANT

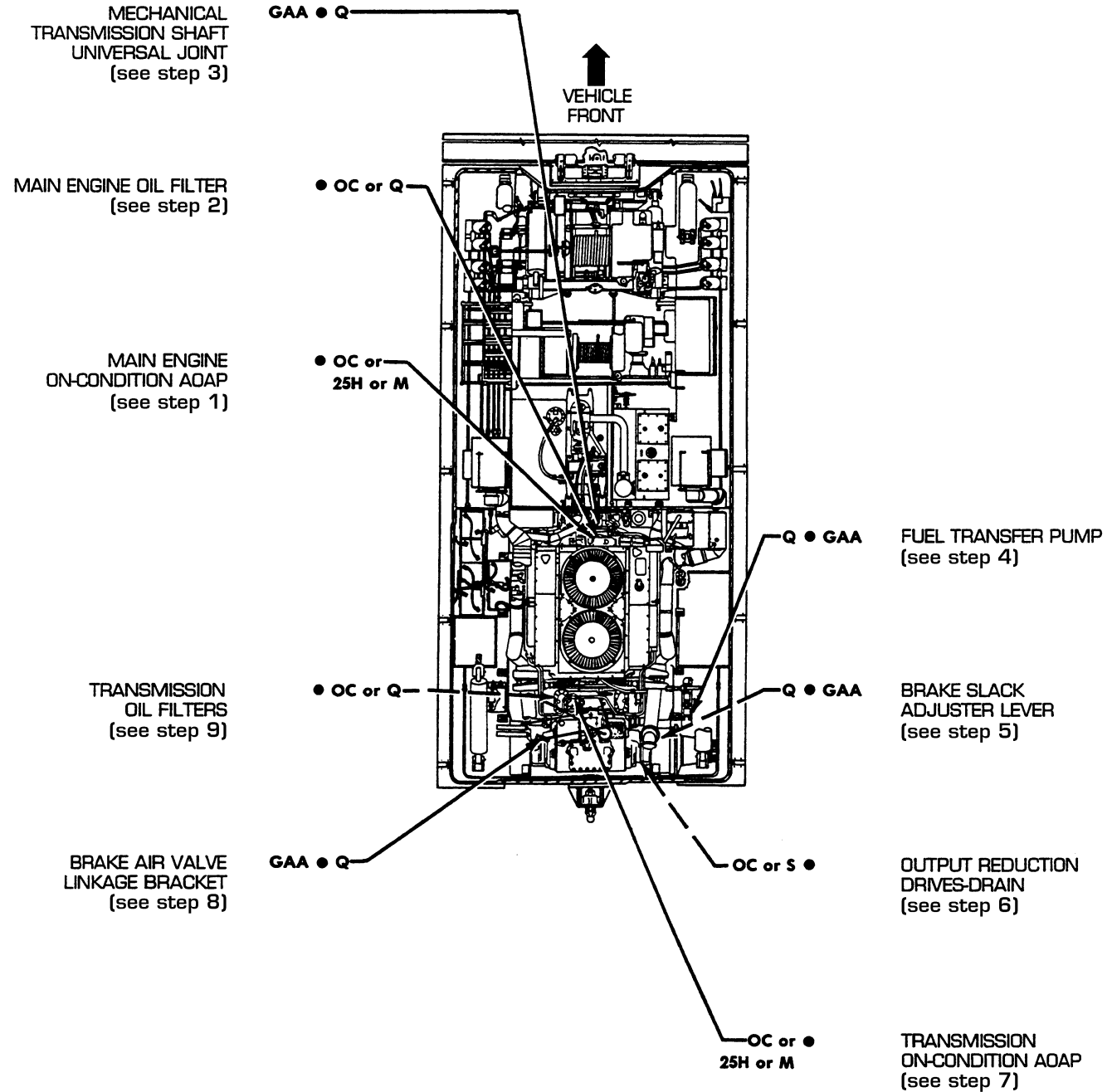

LUBRICANT • INTERVAL

INTERVAL • LUBRICANT

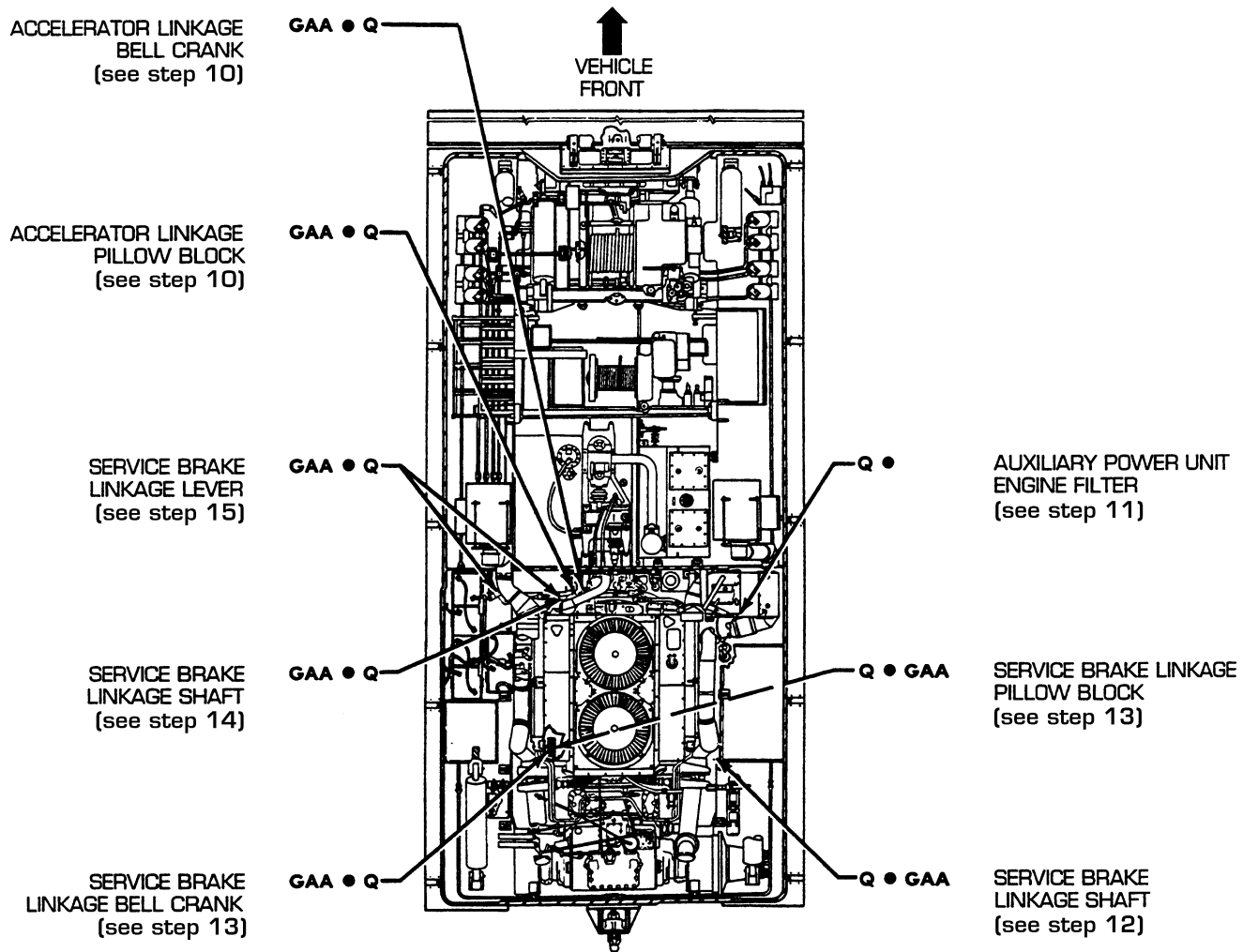

LUBRICANT • INTERVAL

INTERVAL • LUBRICANT

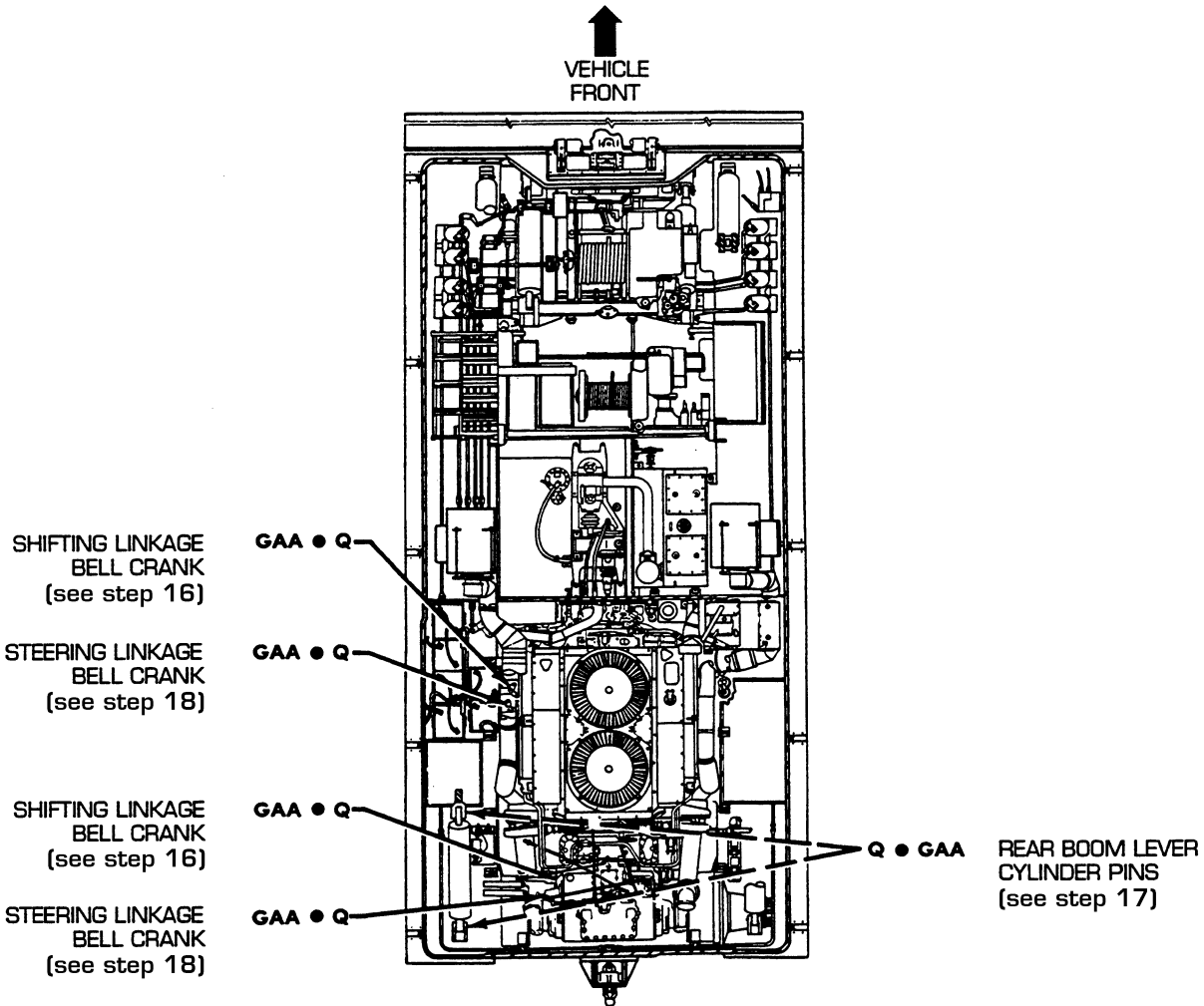

1. AOAP-main engine. For active units, obtain oil samples from engine (1) every 25 hours of operation or 30 days (whichever comes first). Send these samples to nearest AOAP laboratory. Refer to DA PAM 738-750 for sampling instructions. If or when AOAP laboratory support is unavailable, hard-time intervals will apply.

2. Main engine oil filter.

- a. Remove front engine deck grille (2).
- b. Remove oil filter cover (3) (see WP 0104 00) and remove elements (4). Discard removed elements and install new elements.
- c. Install oil filter cover (3) (see WP 0104 00) and front engine deck grille (2).

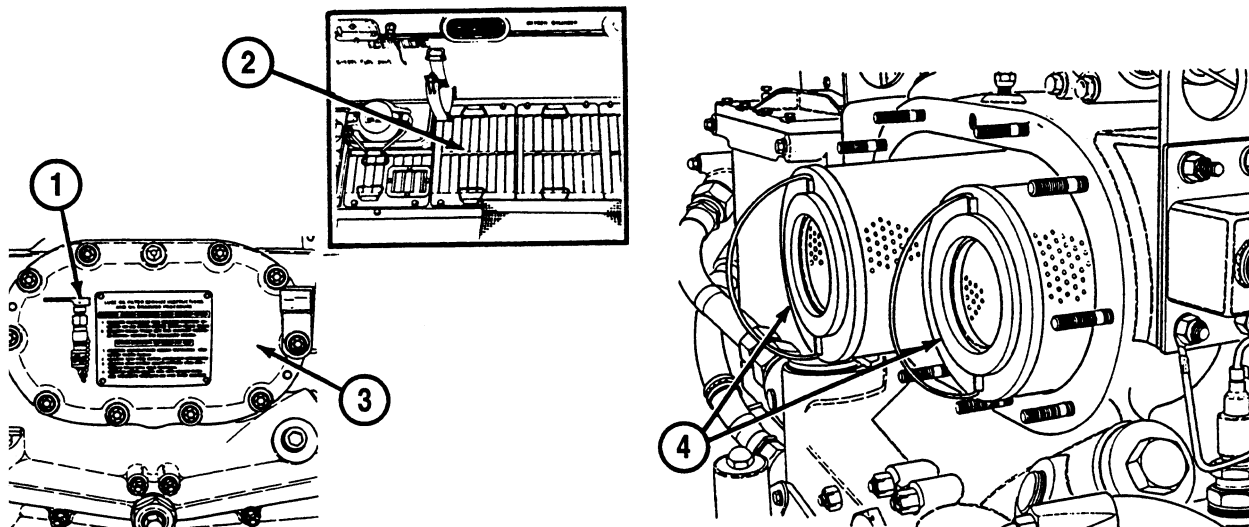

3. Mechanical transmission shaft universal joint. Remove front engine deck grille (2) and lubricate universal joint with GAA through fitting (5). Install front engine deck grille.

4. Fuel transfer pump. Raise engine grille doors (6) and lubricate with GAA through fitting (7). Lower engine grille door.

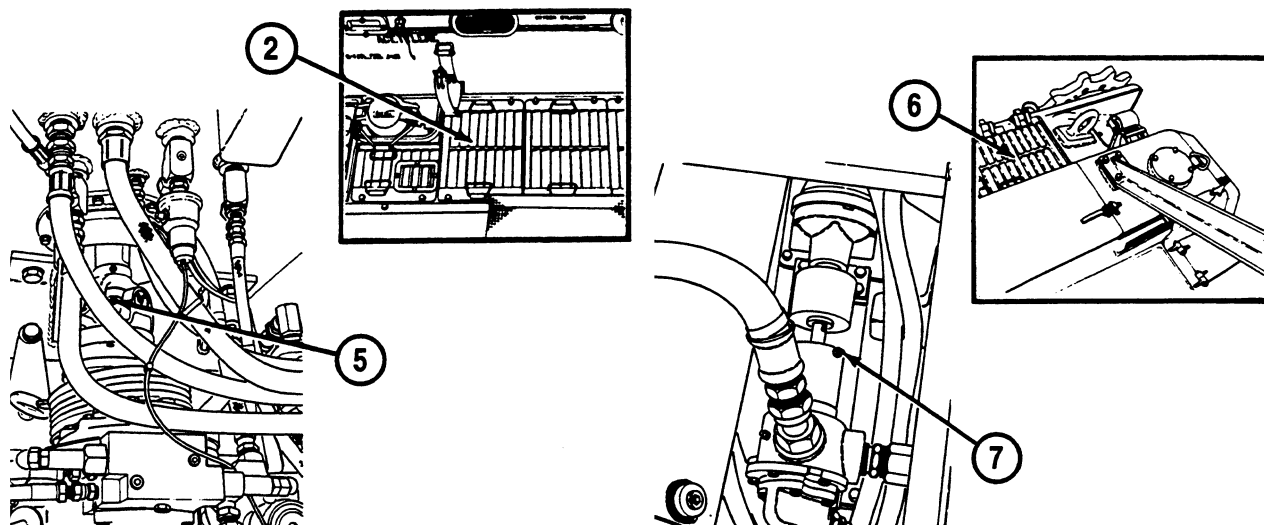

5. Brake slack adjuster lever.
 - a. Remove six screws (8) and six lockwashers (9) which secure brake adjustment access cover (10) to bottom of hull.
 - b. Remove access cover (10) and gasket (11).
 - c. Lubricate brake slack adjuster lever with GAA through fitting (12).
 - d. Install gasket (11), access cover (10), six screws (8), and lockwashers (9). Repeat procedure for other side of vehicle.
6. Output reduction drives—drain.

NOTE

Each time transmission is drained, approximately five gallons of oil remain in each output reduction assembly. Drain oil each time transmission is flushed.

- a. Remove six screws (8) and six lockwashers (9) which secure brake adjustment access cover to bottom of hull.
- b. Remove access cover (10) and gasket (11). Remove bolt (13) located at bottom centerline of saddle mounting face (this is the same bolt that secures end of brake stop to assembly). After oil has drained, install bolt.

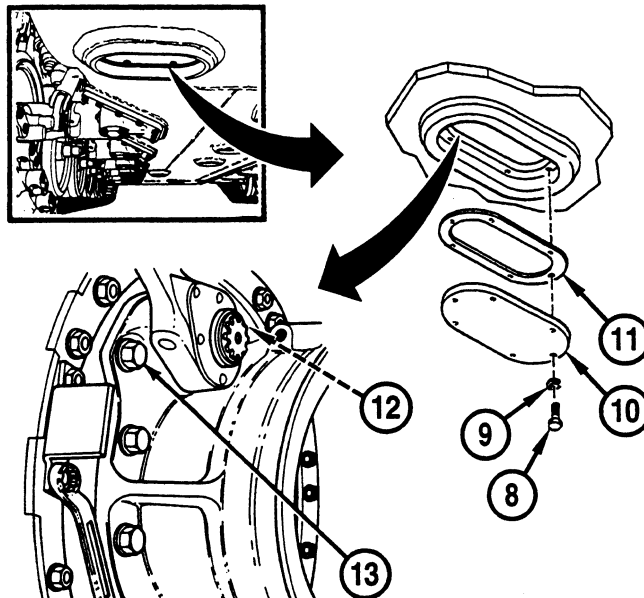

- c. Install gasket (11), access cover (10), six screws (8), and lockwashers (9). Repeat procedure for other side of vehicle.

7. AOAP-transmission. For active units, obtain oil samples from transmission (14) every 25 hours of operation or 30 days (whichever comes first). Send these samples to the nearest AOAP laboratory. Refer to DA PAM 738-750 for sampling instructions. If or when AOAP laboratory support is unavailable, hard-time intervals will apply.

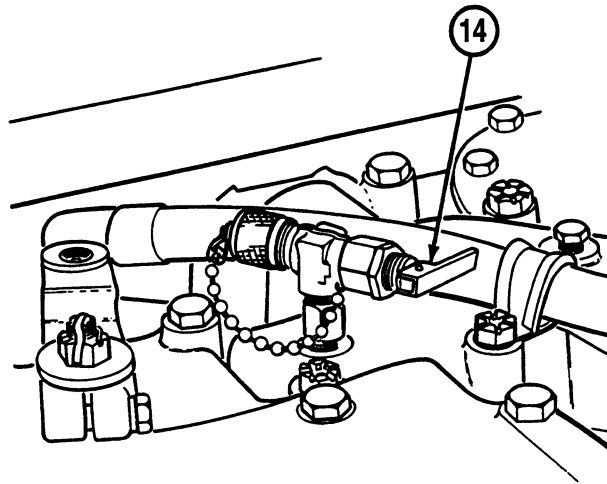

8. Brake air valve linkage bracket.
 - a. Open rear engine deck grille exhaust deflector and grille (15).
 - b. Lubricate linkage with GAA through fitting (16).
 - c. Close rear engine deck grille exhaust deflector and grille (15).

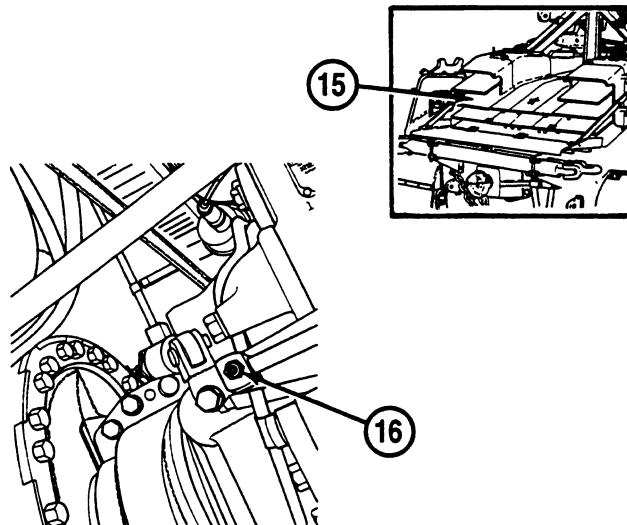

9. Transmission oil filters.

NOTE

There is only one cover plate on each side of transmission.

- a. Open rear engine deck grille exhaust deflector and grille (15). Remove left and right cover plates (17) (see WP 0266 00) and remove four elements (18) (two under each plate).
- b. Clean elements (18) and covers (17) with cleaning compound (item 9, WP 0489).
- c. Install elements (18) and install left and right covers (17) (see WP 0266 00). Close rear engine deck grille exhaust deflector and grille (15).

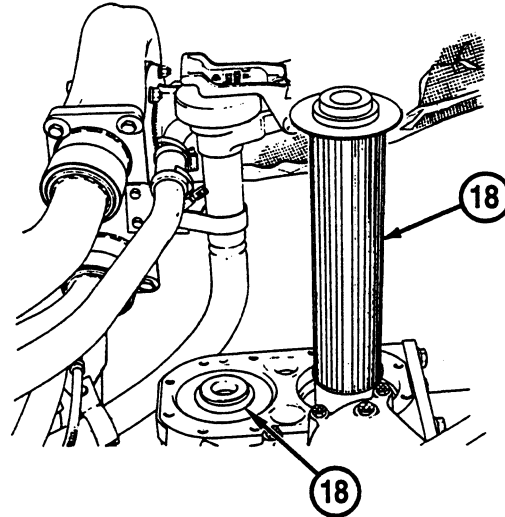
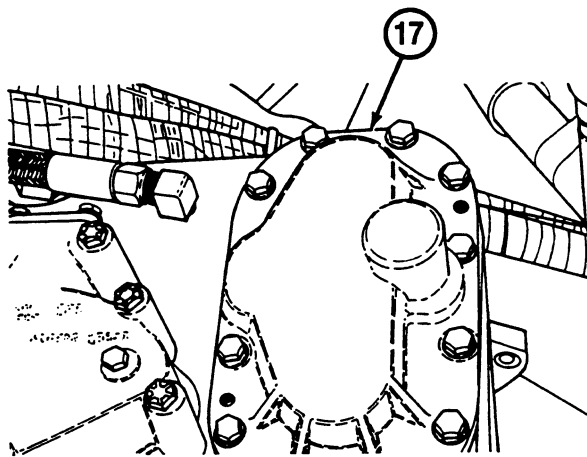

10. Accelerator linkage bell crank and pillow block. Each time engine is removed, lubricate with GAA through bell crank fitting (19) and two pillow block fittings (20).
11. Auxiliary Power Unit (APU) engine oil filter.

WARNING

APU engine is hot after operation. Use caution when reaching into APU compartment.

NOTE

Oil filter should be changed each time the APU engine crankcase oil is changed. Filter should be replaced more frequently when operating in extremely dusty environments.

- a. Open right front engine grille door (21).
- b. Remove oil filter (22) with a wrench, and discard filter.

- c. Lightly lubricate gasket (23) of replacement filter and tighten it until gasket contacts base; then tighten filter (22) an additional one-half turn.

NOTE

Do not overtighten filter.

- d. Start APU engine (refer to TM 9-2350-256-10) and check for oil leaks around filter gasket (23). Tighten filter (22) as necessary if leakage occurs.
- e. Close right front engine grille door (21).

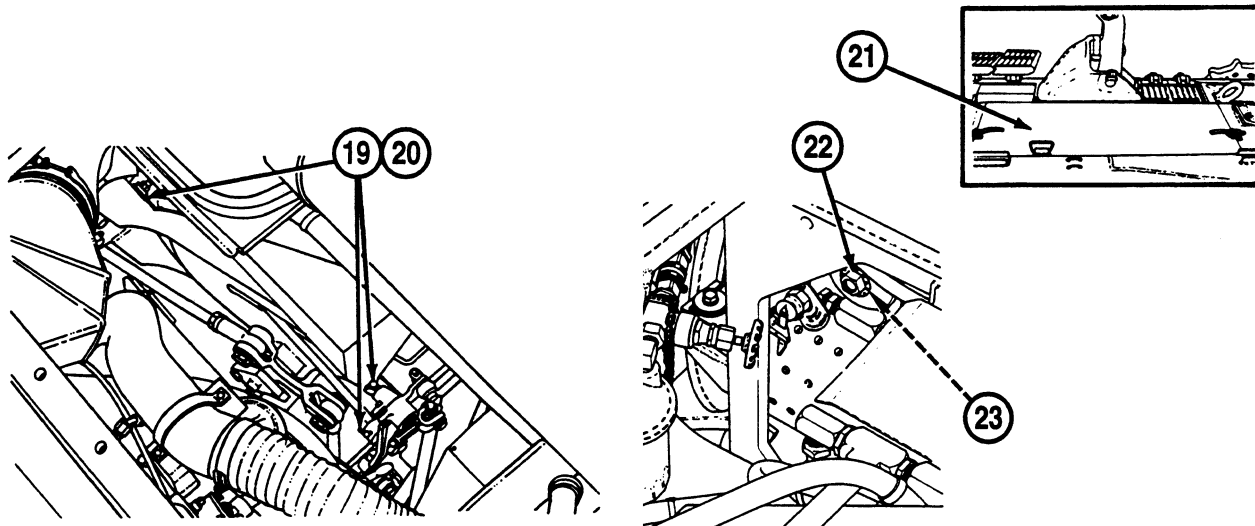

- 12. Service brake linkage shaft. Each time main engine is removed, lubricate with GAA through fitting (24).
- 13. Service brake linkage bell crank and pillow blocks. Each time main engine is removed, lubricate bell cranks through four fittings (25) and lubricate pillow blocks through three fittings (26). Use GAA as lubricant.

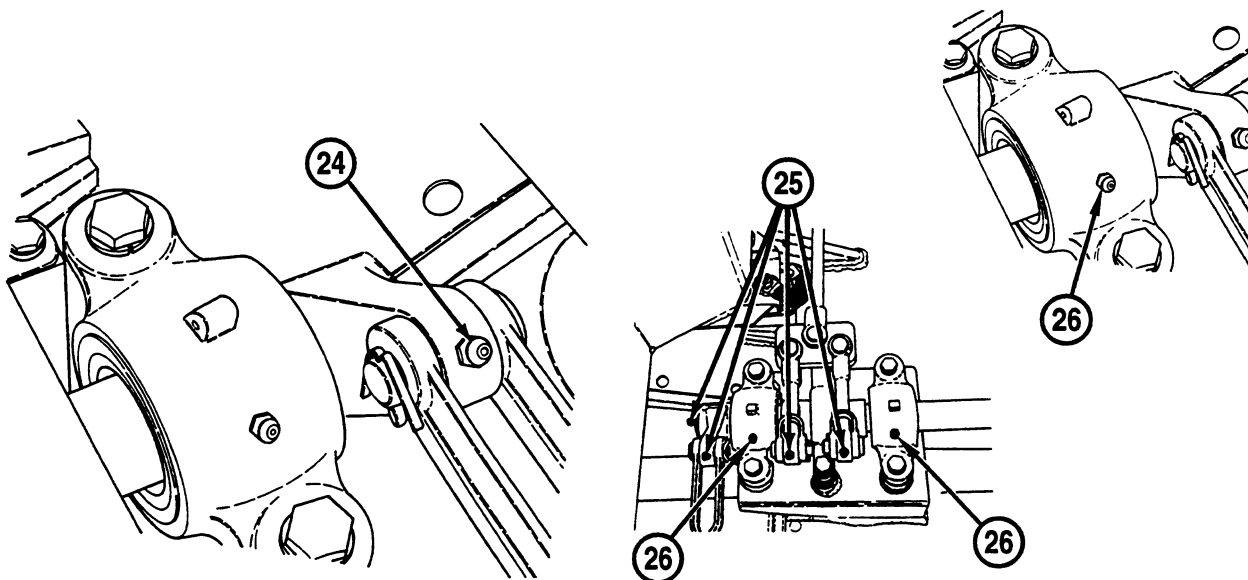

14. Service brake linkage shaft. Each time main engine is removed, lubricate shaft with GAA through fitting (27).
15. Service brake linkage lever. Each time main engine is removed, lubricate lever with GAA through two fittings (28).

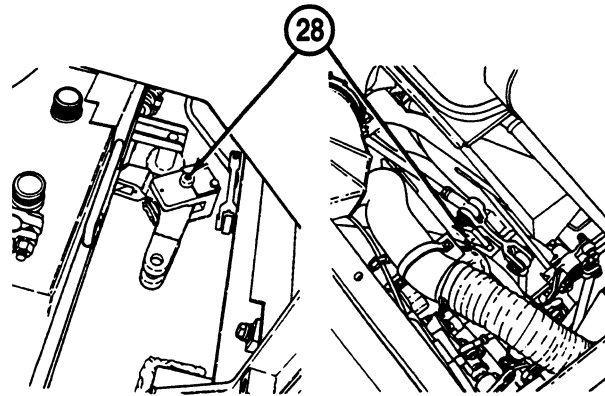
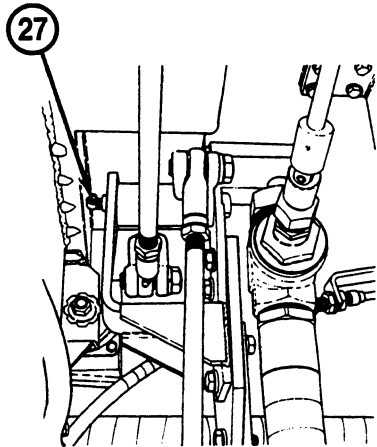

16. Shifting linkage bell crank. Each time main engine is removed, lubricate with GAA through five fittings (29).
17. Rear boom lever cylinder pins.
 - a. Open engine grilles (30) and remove stoplight plate (31).
 - b. Lubricate with GAA through front fittings (32) (accessible through grille) and rear fittings (33) (through stoplight access).
 - c. Install stoplight plate (31) and close engine grilles (30).

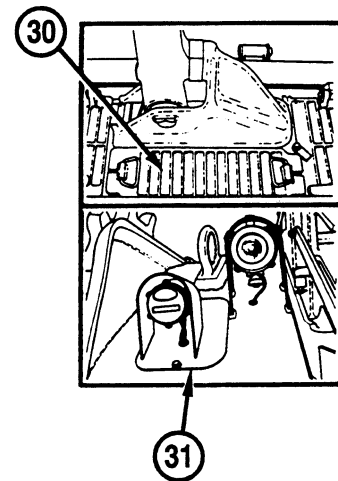
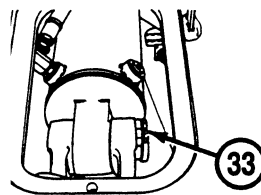
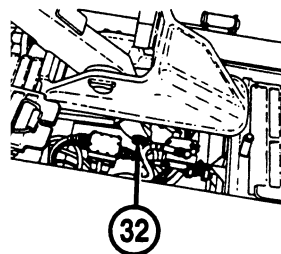
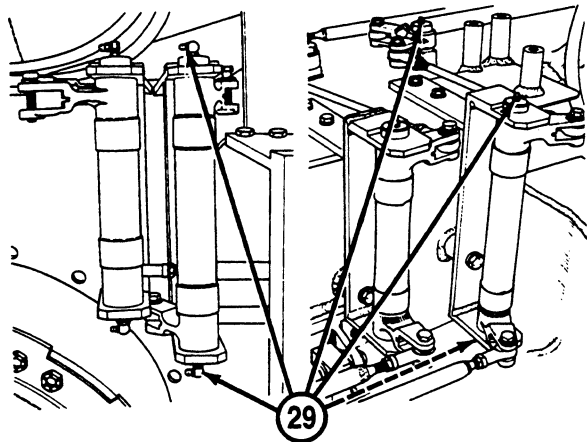

18. Steering linkage bell crank. Each time main engine is removed, lubricate with GAA through five fittings (34).

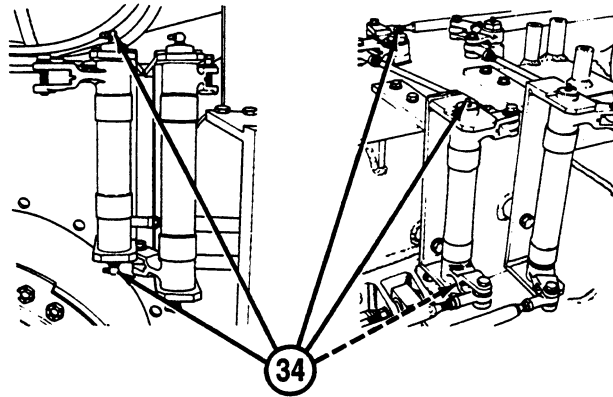

SERVICE FROM APU COMPARTMENT

LUBRICANT • INTERVAL

↑
VEHICLE
FRONT

AUXILIARY POWER UNIT
CRANKCASE DRAIN
(see step 5)

● S or
100 H

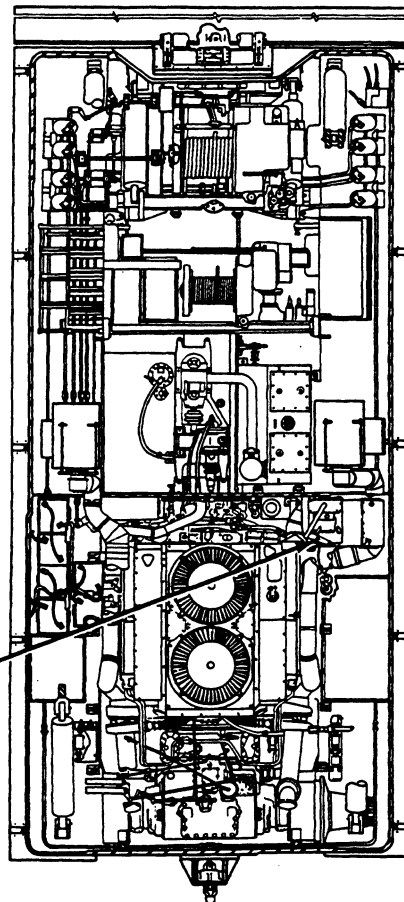

1. APU crankcase drain.

WARNING

APU engine is hot after operation. Use caution when reaching into APU compartment.

NOTE

Drain oil only when hot after operation.

NOTE

Coordinate any seasonal change of oil weight with this service.

- a. Remove six screws (1) and six lockwashers (2) which secure hull drain cover (3) to bottom of hull.
- b. Remove drain plate (3) and gasket (4).
- c. Open right front engine grille door (5).
- d. Open APU crankcase drain valve (6). When oil has drained from crankcase, close drain valve.
- e. Close right front engine grille door (5). Refill engine crankcase with proper grade of oil (see Table 2).
- f. Start APU engine (refer to TM 9-2350-256-10) and check for oil leaks past drain valve (indicated by oil dripping from drain hose). If oil leak is present, double check that drain valve handle is closed securely. Notify Direct Support Maintenance if leakage persists.
- g. Install gasket (4) and engine drain cover (3) at bottom of hull and install six lockwashers (2) and screws (1).

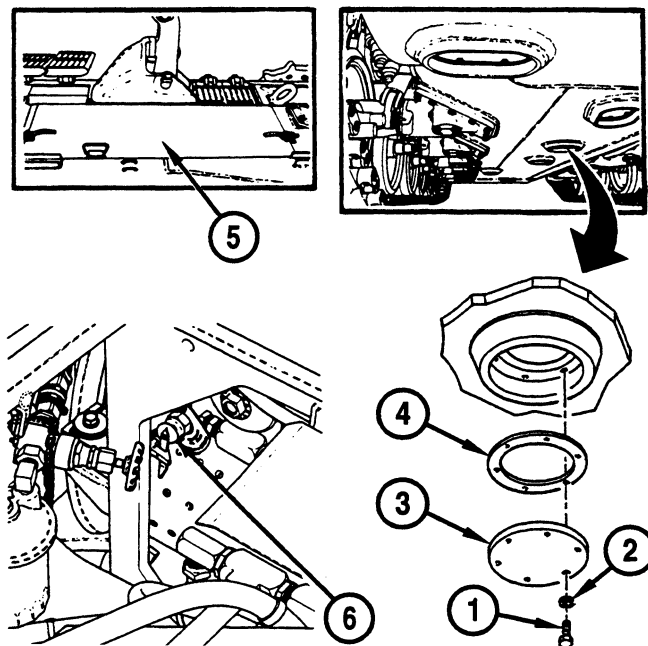

END OF WORK PACKAGE

CHAPTER 4
UNIT MAINTENANCE
MAINTENANCE INSTRUCTIONS
FOR
POWERPLANT
RECOVERY VEHICLE, FULL TRACKED: MEDIUM, M88A1
(NSN: 2350-00-122-6826)

CHAPTER 4
UNIT MAINTENANCE
MAINTENANCE INSTRUCTIONS

WORK PACKAGE INDEX

<u>Title</u>	<u>WP Sequence No.</u>
Powerplant Replacement Removal, Installation.....	0098 00
Groundhop Maintenance Installation, Testing, Removal.....	0099 00
Emergency Boom Operation General, Preparation for Use, Servicing, Placing in Service.....	0100 00
Engine Mounting Bracket Maintenance Removal, Disassembly, Assembly, Installation.....	0101 00
Engine Rear Mount and Base Assembly Replacement Removal, Installation.....	0102 00
Engine Oil Filter Servicing Instruction Plate Replacement Removal, Installation.....	0103 00
Engine Damper Housing, Oil Filter, and Related Parts Maintenance Removal, Cleaning, Installation.....	0104 00
Oil Level Indicator and Related Parts Replacement Removal, Installation.....	0105 00
Oil Filler Tube and Related Parts Replacement Removal, Installation.....	0106 00
Oil Pan and Related Parts Replacement Removal, Installation.....	0107 00
Crankcase Breather Tube Replacement Removal, Installation.....	0108 00
Cylinder Head Oil Pan Drain Tubes and Related Parts Replacement Removal, Installation.....	0109 00
Oil Cooler Pressure-Actuated Bypass Valve Replacement Removal, Installation.....	0110 00
Generator Air Intake Tube Replacement Removal, Installation.....	0111 00
Engine Idle Speed Adjustment.....	0112 00
Engine Solenoid Speed Adjustment.....	0113 00

UNIT MAINTENANCE
RECOVERY VEHICLE, FULL TRACKED: MEDIUM, M88A1
NSN 2350-00-122-6826, EIC AQA
POWERPLANT REPLACEMENT
REMOVAL, INSTALLATION

INITIAL SETUP:**Tools and Special Tools**

Tool kit, general mechanic's (item 59, WP 0490 00)
 Fabricated stop (item 1, WP 0484 00)
 Parts kit, steering clutch housing output shaft (item 34, WP 0490 00)
 Sling, beam-type, powerplant or engine (item 53, WP 0490 00)
 Wrench, torque (item 67, WP 0490 00)

Materials/Parts

Adhesive, sealant, silicone (item 5, WP 0489 00)
 Clamps (4) (item 78, WP 0491 00)
 Clamp (item 343, WP 0491 00)
 Clamp (item 715, WP 0491 00)
 Gasket (item 52, WP 0491 00)
 Gasket (item 87, WP 0491 00)
 Lockwashers (2) (item 349, WP 0491 00)
 Lockwasher (item 616, WP 0491 00)
 Lockwashers (3) (item 623, WP 0491 00)
 Lockwashers (10) (item 640, WP 0491 00)
 Lockwashers (16) (item 642, WP 0491 00)
 Lockwashers (6) (item 646, WP 0491 00)
 Lockwire (item 482, WP 0491 00)
 Nut (item 490, WP 0491 00)
 Packing, preformed (item 264, WP 0491 00)
 Pin, cotter (item 108, WP 0491 00)

Materials/Parts (cont.)

Pins, cotter (2) (item 520, WP 0491 00)
 Pins, straight (2) (item 68, WP 0491 00)
 Screw (item 376, WP 0491 00)
 Screws (6) (item 393, WP 0491 00)
 Screws (3) (item 396, WP 0491 00)
 Screws (2) (item 399, WP 0491 00)
 Screws (4) (item 401, WP 0491 00)
 Screws (2) (item 402, WP 0491 00)
 Screws (12) (item 410, WP 0491 00)
 Screws (3) (item 417, WP 0491 00)
 Screws (4) (item 475, WP 0491 00)
 Screws (3) (item 721, WP 0491 00)
 Screws (2) (item 804, WP 0491 00)
 Washer, flat (item 128, WP 0491 00)

Personnel Required

Mechanics (3)

References

WP 0334 00
 TM 9-2350-256-10

Equipment Condition

Engine deck removed (see WP 0336 00)
 Vehicle track blocked (refer to TM 9-2350-256-10)

WARNING

Keep hands and arms away from propeller shaft while bumping engine or serious injury to personnel will result.

NOTE

For removal and installation instructions, engine and transmission will be referred to as the powerplant.

NOTE

If necessary to turn propeller shaft to reach screws, turn MASTER switch to ON position. Hold FUEL SHUTOFF switch in OFF position and touch STARTER switch. When screws are in position for removal, turn MASTER switch to OFF position.

Removal

1. Cut lockwire (1) and remove from screws (2).
2. Remove four screws (2) and four lockwashers (3) from power takeoff coupling (4).
3. Slide propeller shaft (5) toward bulkhead.

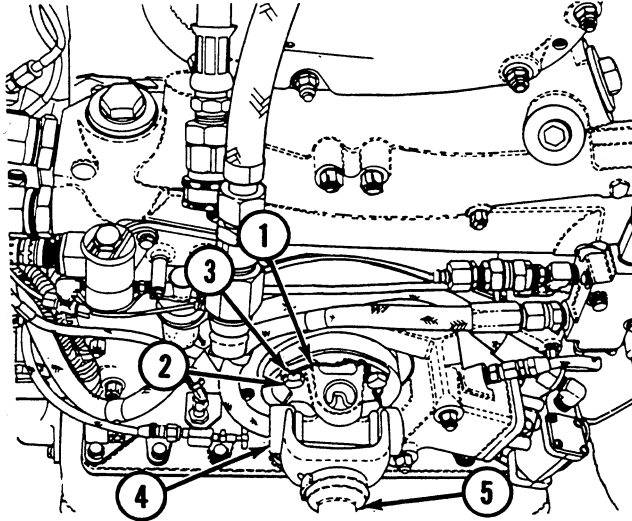

4. Disconnect transmission steering rod (6) by removing screw (7) and lockwasher (8).
5. Disconnect transmission shifting rod (9) by removing screw (10) and lockwasher (11).
6. Disconnect four electrical cables (12) to engine wiring harness bracket (13).

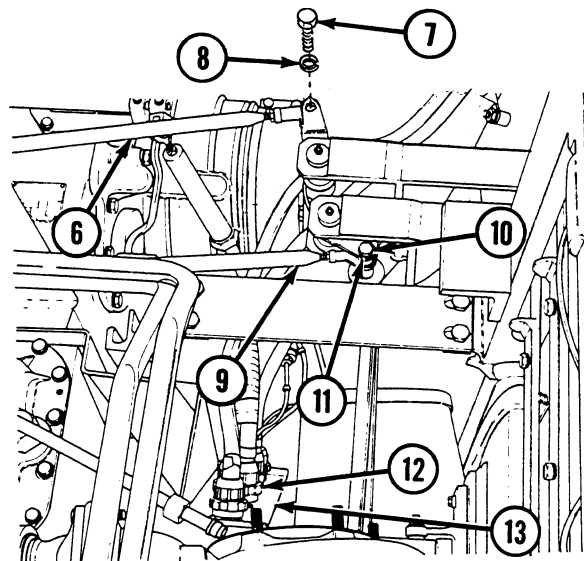

NOTE

Engine exhaust pipe shown removed for clarity.

7. Remove brake air valve linkage (14) by removing two cotter pins (15) and two straight pins (16).

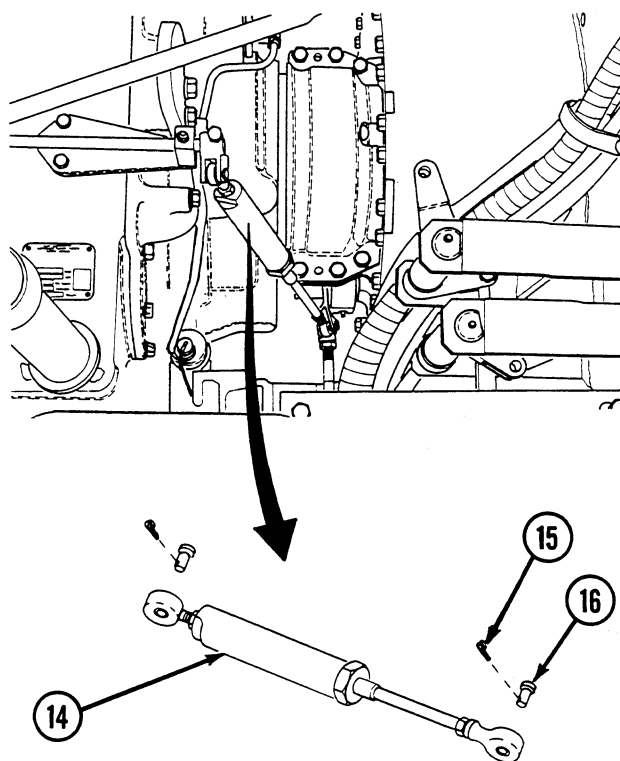

CAUTION

Do not scratch or damage saddle caps. A defective cap may cause oil leaks after installation. Remove nicks and burrs prior to installation.

8. Remove six screws (17) and six lockwashers (18) each from left and right transmission mounting saddle caps (19).
9. Remove left and right transmission mounting saddle caps (19) by using one of previously removed screws (17) as jacking screw in tapped hole (20).

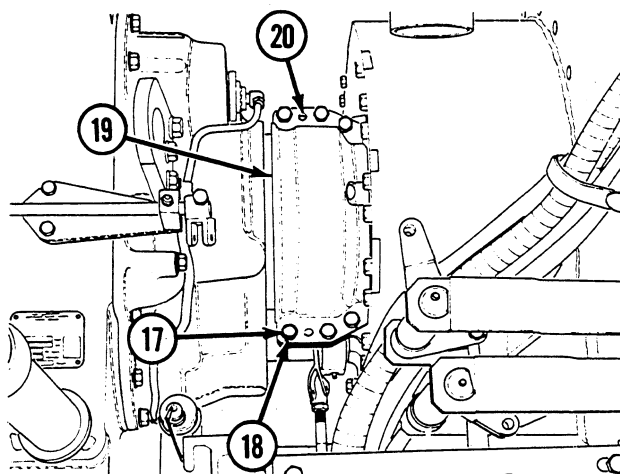

10. Remove left and right coupling retainers (21).
11. Place each fabricated stop (22) between left and right output reduction unit and flanges.

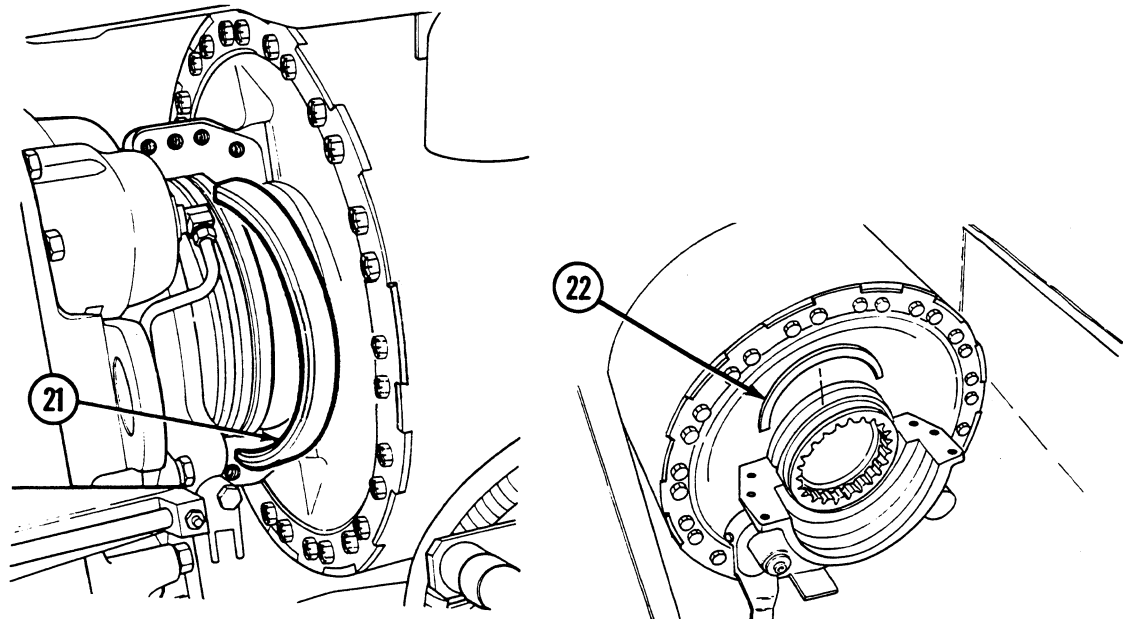

12. Pry couplings (23) out of left and right output reduction drive units (24).
13. Remove APU access cover (see WP 0334 00).
14. Loosen clamp (25).
15. Remove APU cooling air duct (26) by removing three screws (27) and three lockwashers (28).

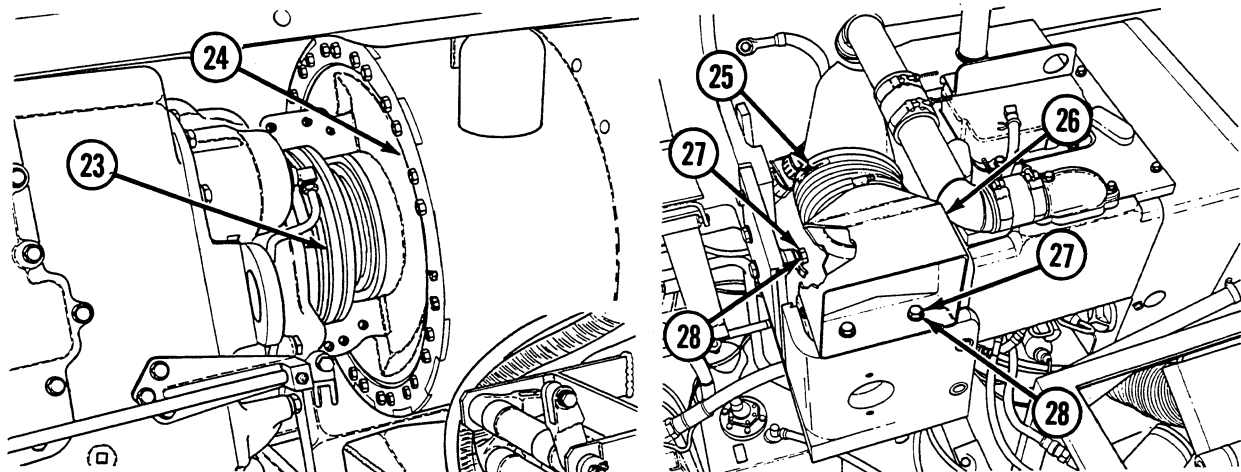

16. Remove personnel heater exhaust hose assembly (29) by removing four screws (30), four lockwashers (31), gasket (32), two screws (33), two lockwashers (34), and gasket (35).
17. Remove APU housing (36) by removing three screws (37) and three lockwashers (38).

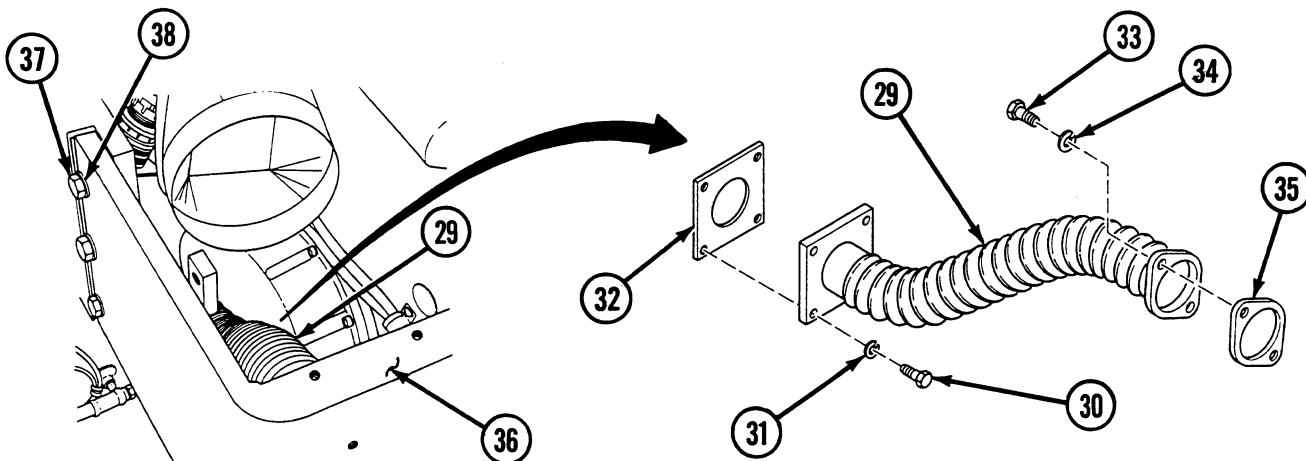

18. Loosen clamp (39) and disconnect generator air intake hose (40).
19. Disconnect throttle linkage (41) by removing screw (42) and nut (43) and pulling hand throttle at driver's control all the way out.
20. Disconnect tachometer cable (44).
21. Disconnect emergency fuel shutoff linkage (45) by removing flat washer (46) and cotter pin (47) from link (48).
22. Remove emergency fuel shutoff linkage bracket (49) by removing two screws (50) and two lockwashers (51).

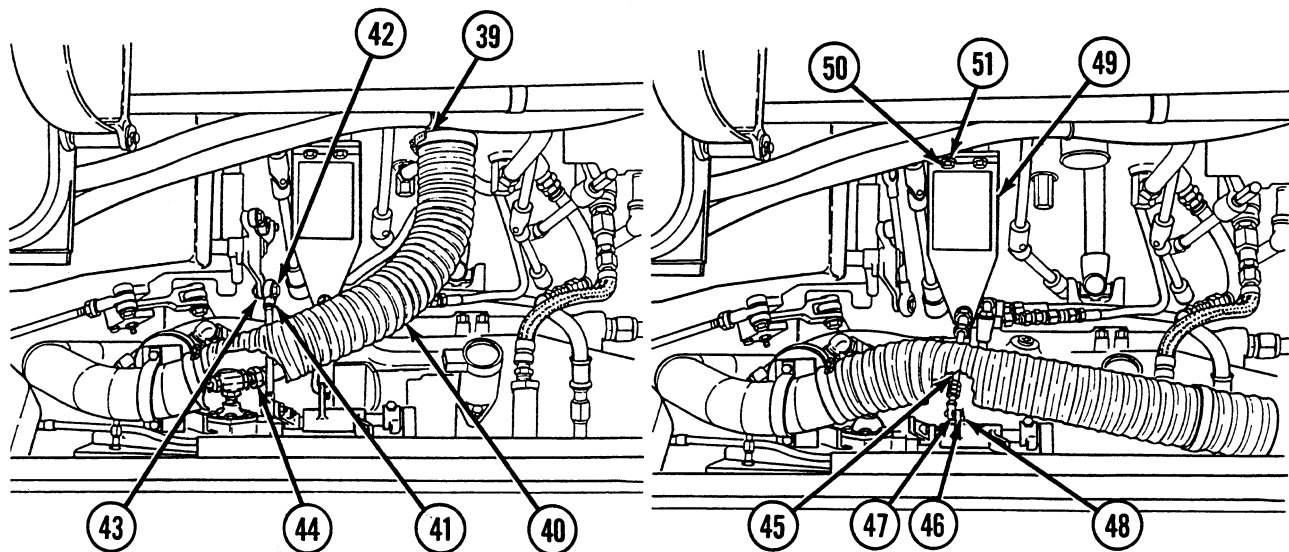

23. Disconnect fuel return hose (52) at quick disconnect.
24. Disconnect primer hose (53) at quick disconnect.
25. Disconnect main fuel hose (54) at quick disconnect.
26. Disconnect fire extinguisher line (55) at quick disconnect.

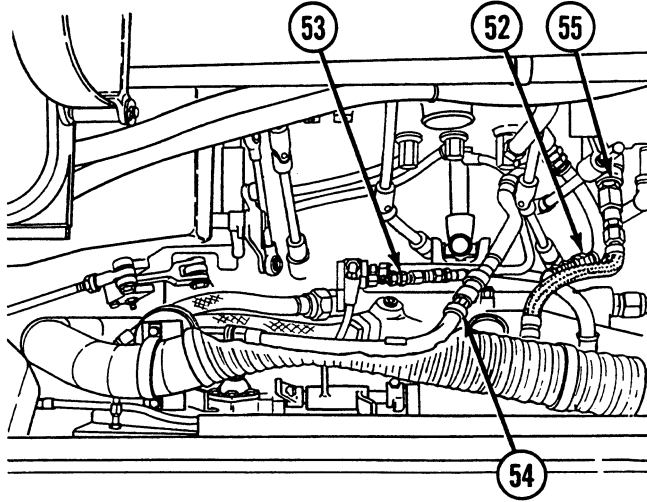

NOTE

Cover turbosupercharger openings with tape or caps after removal of air ducts.

27. Remove vehicle left-side air ducts (56) by loosening hose clamps (57 and 58) and removing two screws (59) and two lockwashers (60).

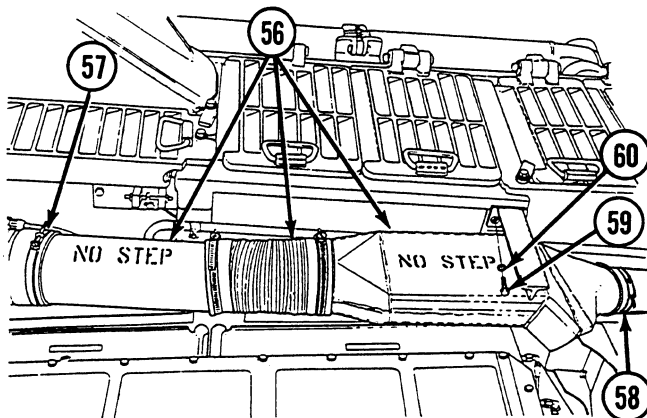

28. Remove vehicle right-side air ducts (61) by loosening hose clamps (62 and 63). Then remove strap (64) and bar (65) by removing two screws (66) and two lockwashers (67).

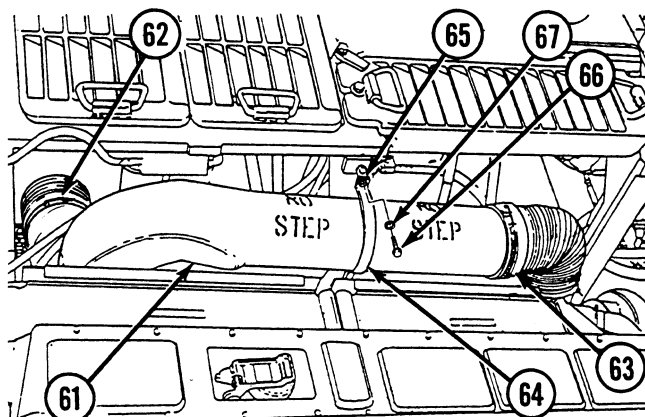

NOTE

Perform step 29a for normal conditions. Perform step 29b if engine mount release rod is inoperable from engine opening.

29. Release engine mount (68).
- Turn engine mount release rod (69) counterclockwise.
 - Remove access cover (70) by removing six screws (71) and six lockwashers (72). Turn bolt (73) counterclockwise to release engine mount (68).

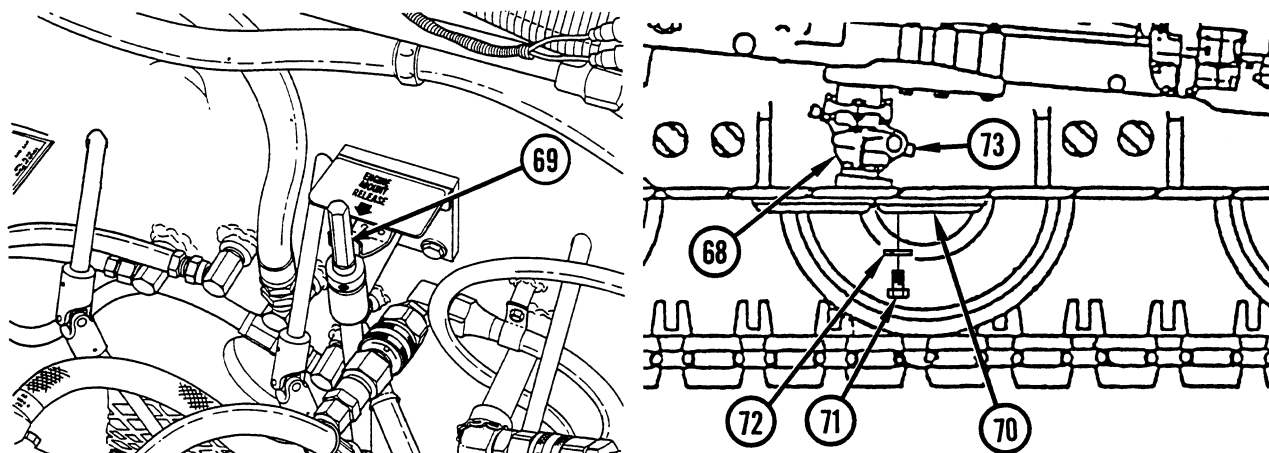

WARNING

All personnel must stand clear during lifting operations. A swinging or shifting load may cause injury or death to personnel.

NOTE

Sling (74) is premarked to ensure proper rigging for powerplant (75) removal.

30. Remove powerplant (75) from vehicle hull (76) using sling (74).
31. Remove two preformed packings (77) from each side of transmission saddle (78).

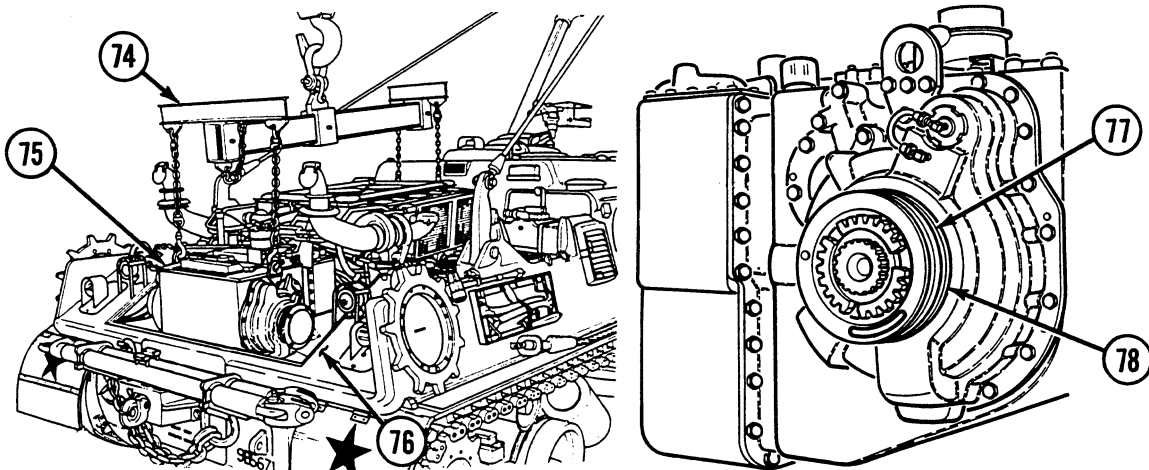
**CAUTION**

Do not step on shifting, steering, or brake linkages after removing powerplant. Damage to linkages could result.

32. Install steering clutch housing output shaft parts kit (79). Cover ends of left and right output reduction assemblies in hull with tape or other suitable item after removal of powerplant.

Installation

NOTE

Prior to installation, inspect and adjust fire extinguisher nozzles in engine compartment and check that all powerplant lines, cables, accessories, and other components are properly installed, tightened, and adjusted. Inspect transmission output reduction drives and engine mountings and connections in engine compartment to determine if items are serviceable and positioned to receive powerplant.

NOTE

Clean (flush) engine compartment prior to installation of powerplant.

NOTE

Prior to installation of powerplant, perform necessary engine compartment lubricating procedures (refer to TM 9-2350-256-10).

1. Remove steering clutch housing output shaft parts kit (79). Uncover left and right output reduction assemblies in hull.

CAUTION

When installing powerplant, be sure transmission guide rollers (80) are inserted into transmission guide rails (81).

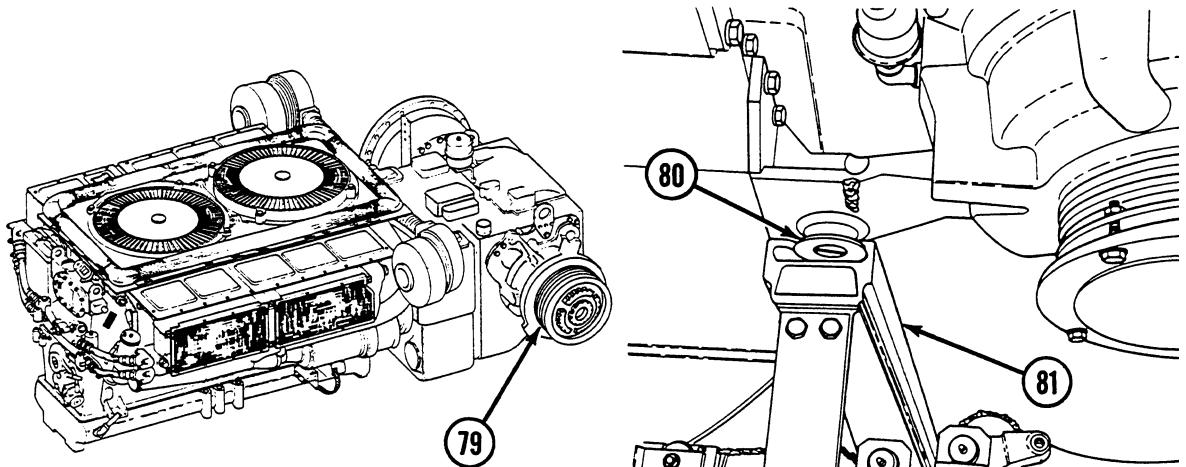

NOTE

Be sure that all tape, caps, and other protective closure items have been removed before installation.

2. Install two preformed packings (77) on each side of transmission saddle (78).

WARNING

All personnel must stand clear during lifting operation. A swinging or shifting load may cause injury or death to personnel.

3. Install powerplant (75) in vehicle hull (76) using sling (74).

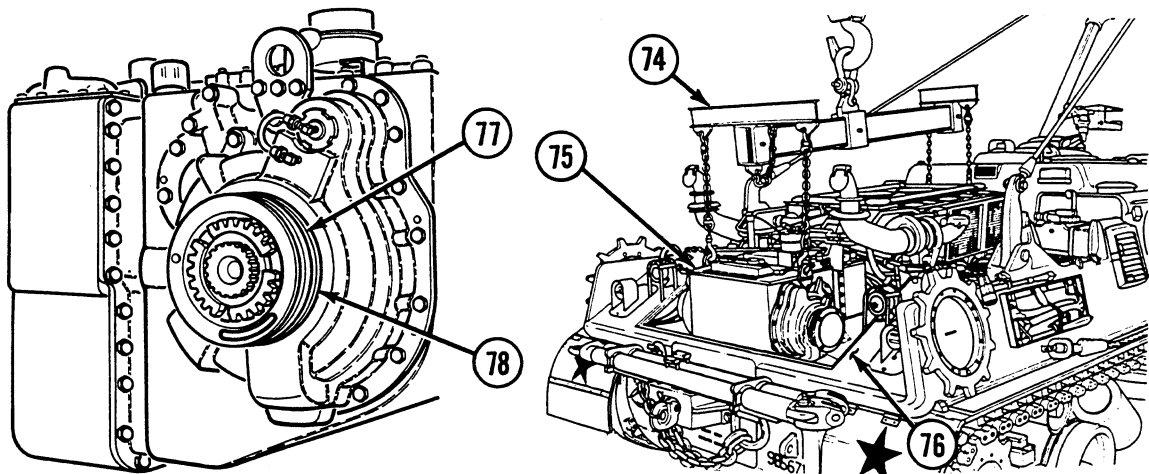

4. Torque engine mount release rod (69) to 42–48 pound-feet (lb-ft) (57–65 newton-meters [N•m]) to secure engine to hull.

NOTE

Perform step 5 if engine mount (68) was accessed and released from underneath the hull.

5. Install access cover (70) with six lockwashers (72) and six screws (71).

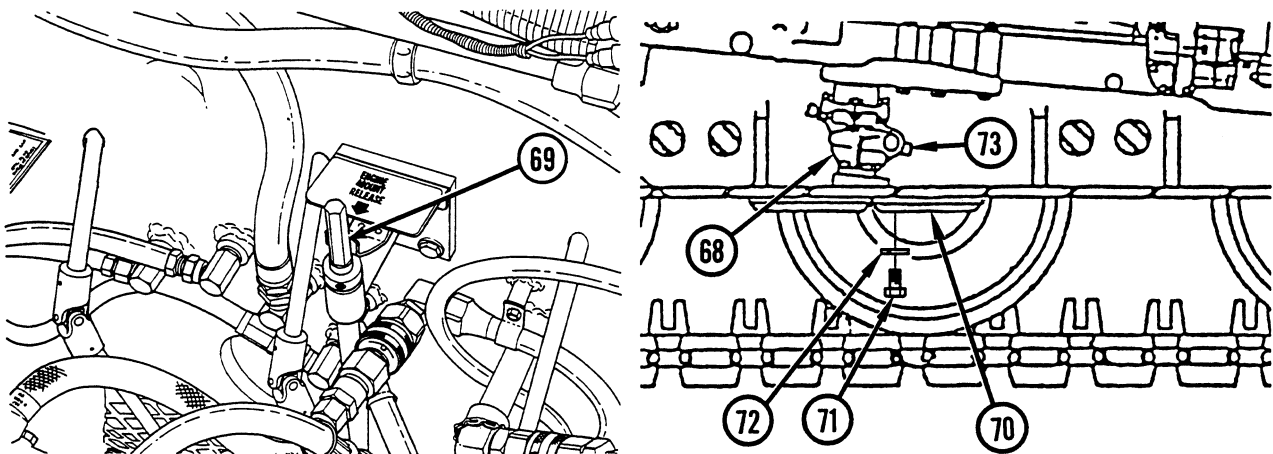

6. Install vehicle right-side air ducts (61). Secure with strap (64) and bar (65) using two screws (66) and two lockwashers (67). Place ends of duct into hose clamps (62 and 63). Tighten clamps.
7. Install vehicle left-side air ducts (56). Secure with two screws (59) and two lockwashers (60). Place ends of duct into hose clamps (57 and 58). Tighten clamps.

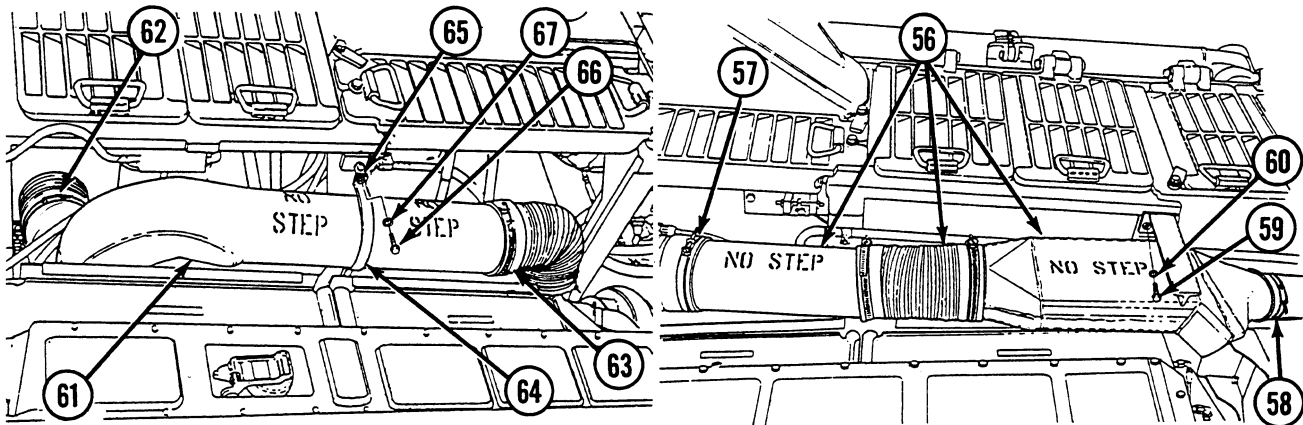

8. Connect fire extinguisher line (55), main fuel hose (54), primer hose (53), and fuel return hose (52).
9. Install emergency fuel shutoff linkage bracket (49) with two screws (50) and two lockwashers (51).
10. Connect emergency fuel shutoff linkage (45) to link (48) with flat washer (46) and cotter pin (47).

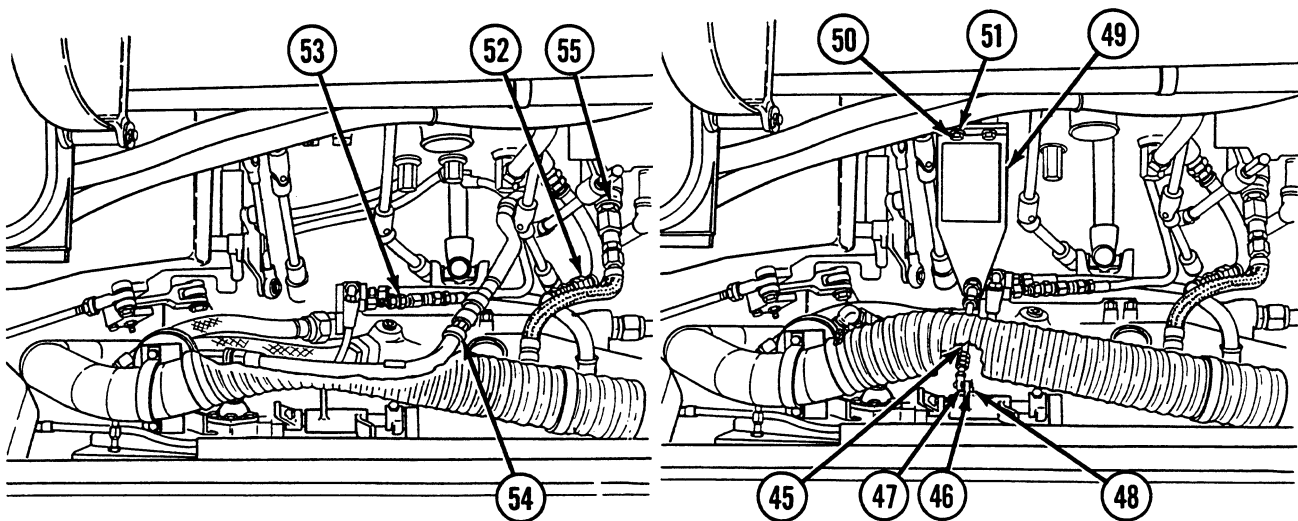

11. Connect tachometer cable (44).
12. Push hand throttle at driver's control all the way in and connect throttle linkage (41) by installing screw (42) and nut (43).
13. Connect generator air intake hose (40) by tightening clamp (39).

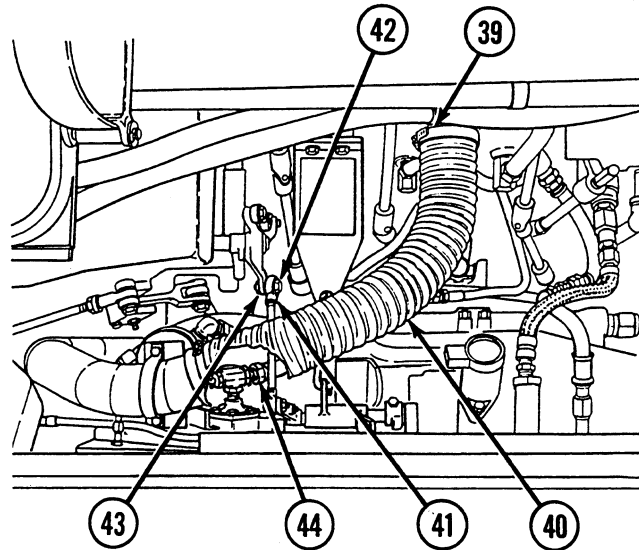

14. Install APU housing (36) with three screws (37) and three lockwashers (38).
15. Install personnel heater exhaust hose assembly (29) with four screws (30), four lockwashers (31), gasket (32), two screws (33), two lockwashers (34), and gasket (35).

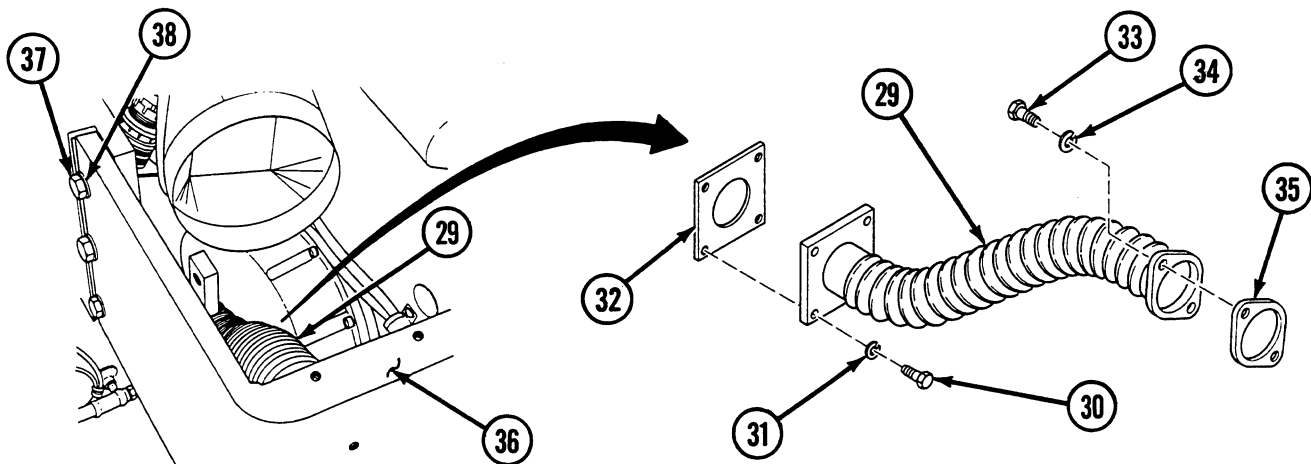

16. Install APU cooling air duct (26) with three screws (27) and three lockwashers (28). Tighten clamp (25).

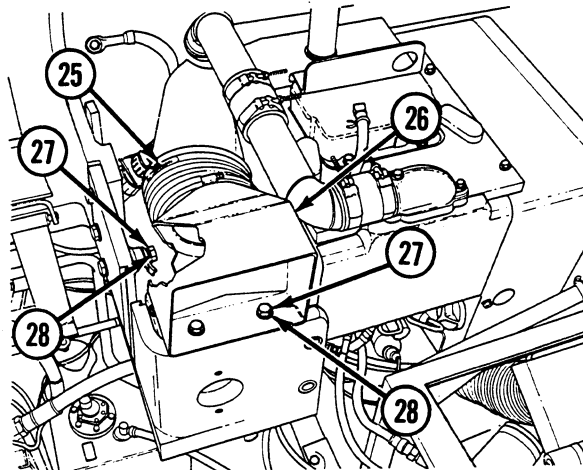

17. Install APU access cover (see WP 0334 00).
 18. Install brake air valve linkage (14) with two straight pins (16) and two cotter pins (15).

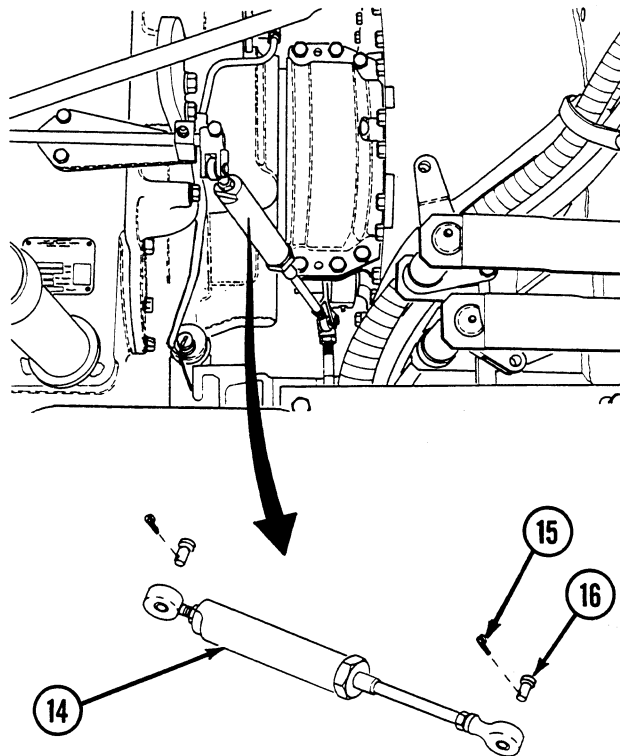

19. Connect four electrical cables (12) to engine wiring harness bracket (13).
20. Connect transmission shifting rod (9) with screw (10) and lockwasher (11).
21. Connect transmission steering rod (6) with screw (7) and lockwasher (8).

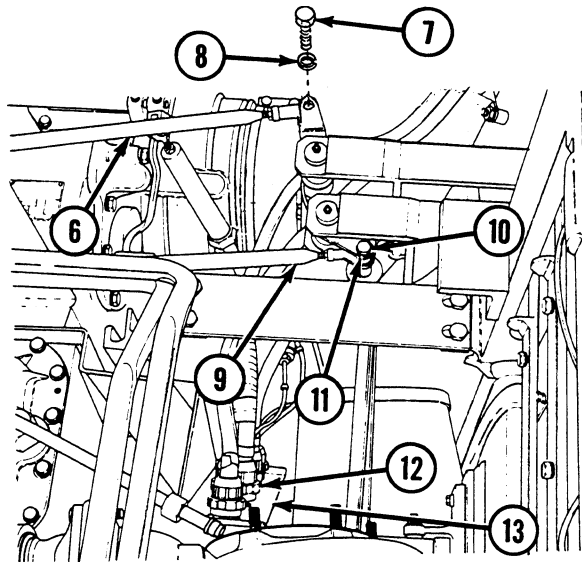

WARNING

Keep hands and arms away from propeller shaft while engine is running, or serious injury to personnel will result.

NOTE

If necessary to turn propeller shaft to align screw holes, turn MASTER switch to ON position. Hold FUEL SHUTOFF switch in OFF position and touch STARTER switch. When holes are in position for installation, turn MASTER switch to OFF position.

22. Slide propeller shaft (5) into position on power takeoff coupling (4) and secure with four screws (2) and four lockwashers (3). Secure four screws with lockwire (1).

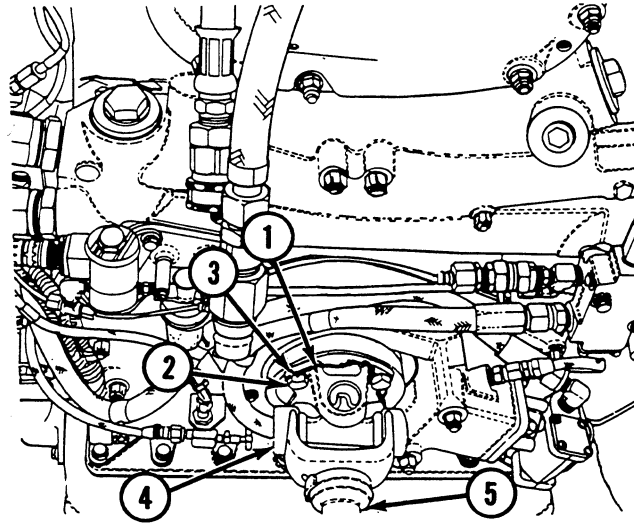

23. Remove both fabricated stops (22).
24. Remove access plug (82) from left steer clutch housing (83).

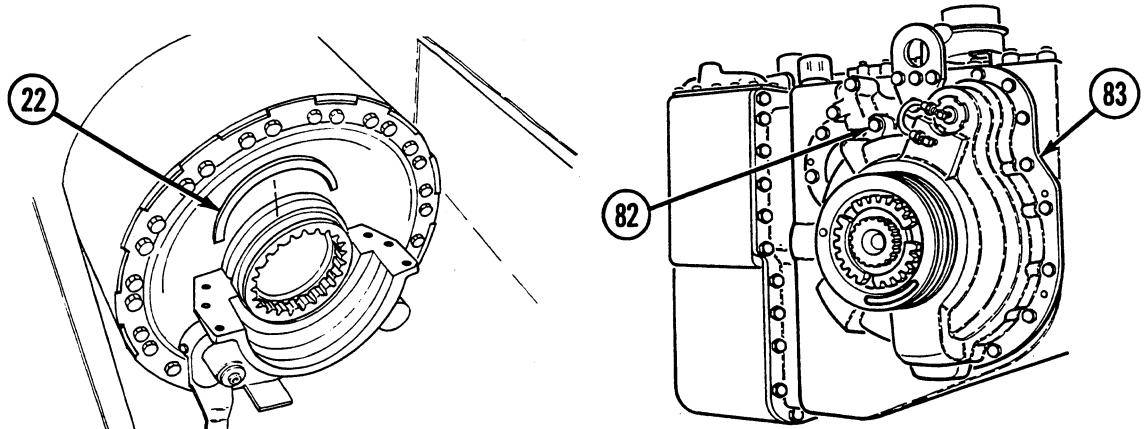

NOTE

Ensure that vehicle is in N (neutral) with brakes released and tracks blocked before attempting to rotate steering tie shaft.

25. Insert screwdriver in hole and engage slot in steering tie shaft.
26. Using a second screwdriver, apply pressure on right coupling (23) flange toward steer clutch housing and simultaneously turn steering tie shaft until gear teeth mesh. It may be necessary to use a 12-in. (305-mm) adjustable, open-end wrench on screwdriver to turn steering tie shaft. Minimum vertical movement of coupling may require a piece of wire for support while engaging gear teeth.

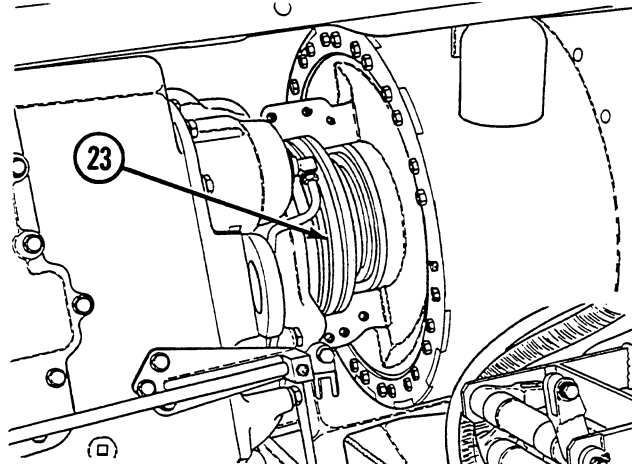

27. Repeat steps 24 and 25 for opposite side.
28. Install left and right coupling retainers (21).

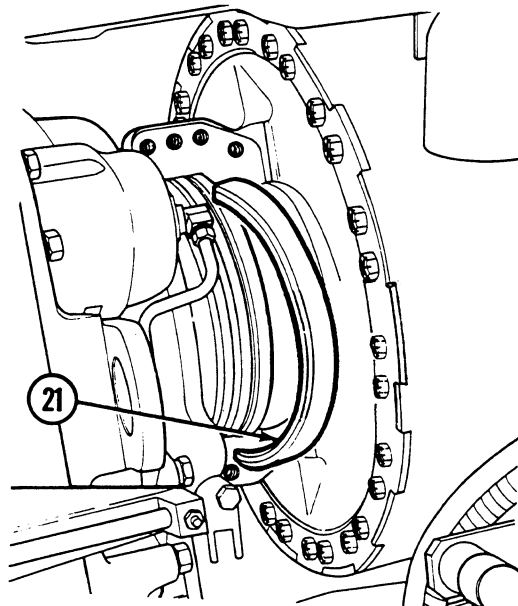

NOTE

Scratched or damaged saddle caps can cause oil leaks. Remove nicks and burrs prior to installation.

29. Install left and right transmission mounting saddle caps (19) each with six screws (17) and six lockwashers (18).

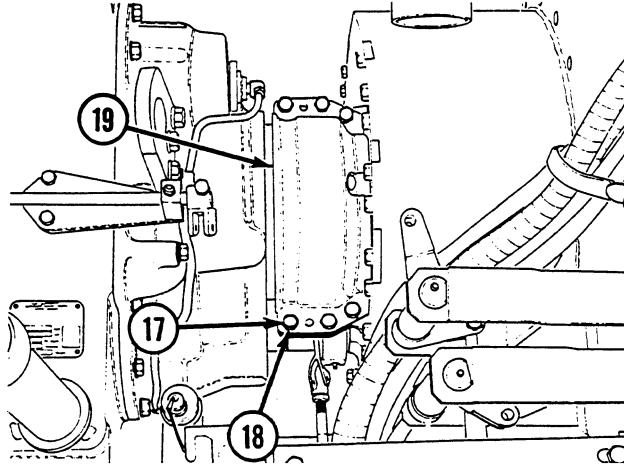
**NOTE**

Apply silicone sealant adhesive uniformly on saddle cap split line on both sides of transmission.

30. Install access plug (82) in left steer clutch housing (83).

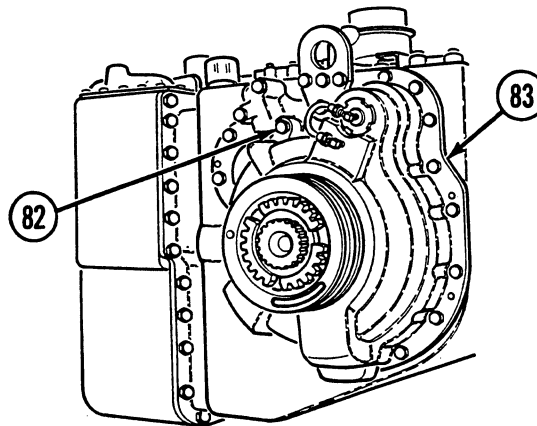

31. Start engine and listen for unusual noises or abnormal conditions (refer to TM 9-2350-256-10).

NOTE

Follow-on maintenance: Install engine deck (see WP 0336 00).

END OF WORK PACKAGE

UNIT MAINTENANCE
RECOVERY VEHICLE, FULL TRACKED: MEDIUM, M88A1
NSN 2350-00-122-6826, EIC AQA

GROUNDHOP MAINTENANCE
INSTALLATION, TESTING, REMOVAL

INITIAL SETUP:**Tools and Special Tools**

Tool kit, general mechanic's (item 59, WP 0490 00)
Cable assembly, accessories (item 5, WP 0490 00)
Cable assembly, generator armature (item 6, WP 0490
00)
Cable assembly, ground (item 7, WP 0490 00)
Cable assembly, starter (item 8, WP 0490 00)
Clamp (item 10, WP 0490 00)
Filter assembly (item 15, WP 0490 00)
Hose (item 21, WP 0490 00)

Tools and Special Tools (cont.)

Hose assembly, engine primer (item 25, WP 0490 00)
Hose assembly, main fuel line and fuel injector return
(item 26, WP 0490 00)

Personnel Required

Mechanics (2)

Equipment Condition

Powerplant removed (see WP 0098 00)

Installation

1. Connect generator armature cable assembly (1), ground cable assembly (2), starter cable assembly (3), and accessories cable assembly (4) between vehicle (5) and engine wiring harness bracket (6).
2. Connect fuel return hose (7) at quick disconnects in vehicle and on engine.
3. Connect primer fuel hose (8) at quick disconnects in vehicle and on engine.
4. Connect main fuel hose (9) at quick disconnects in vehicle and on engine.

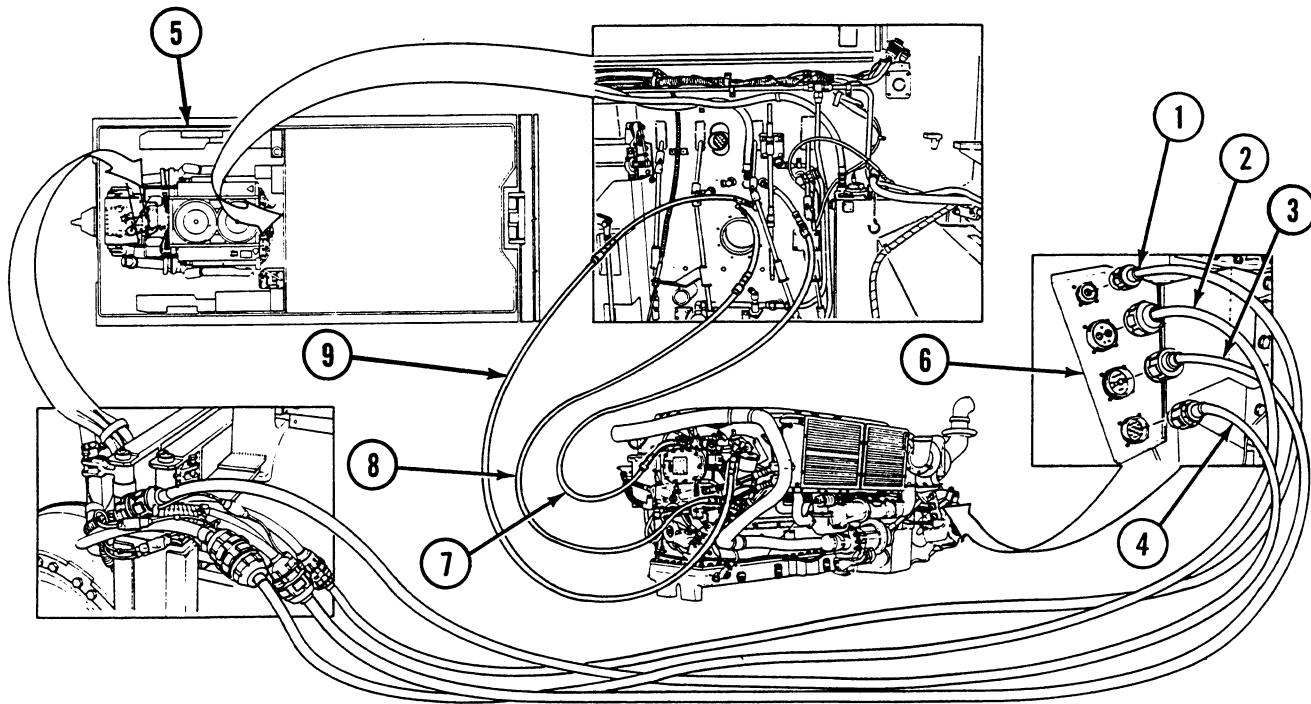

NOTE

Right and left filter assemblies are installed in the same manner.

5. Remove clamp (10) and cover (11).

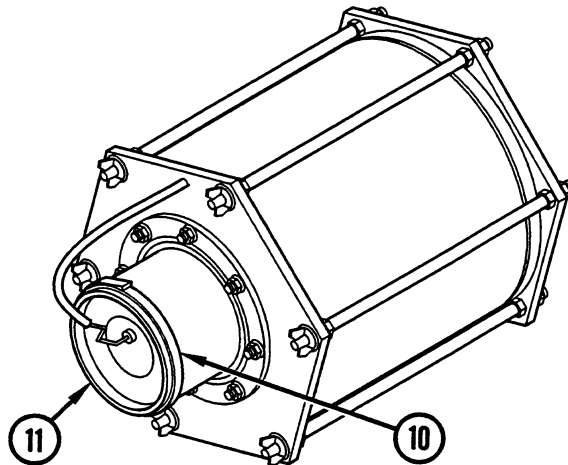

6. Install hose (12), two clamps (13), and filter assembly (14) to turbocharger (15).

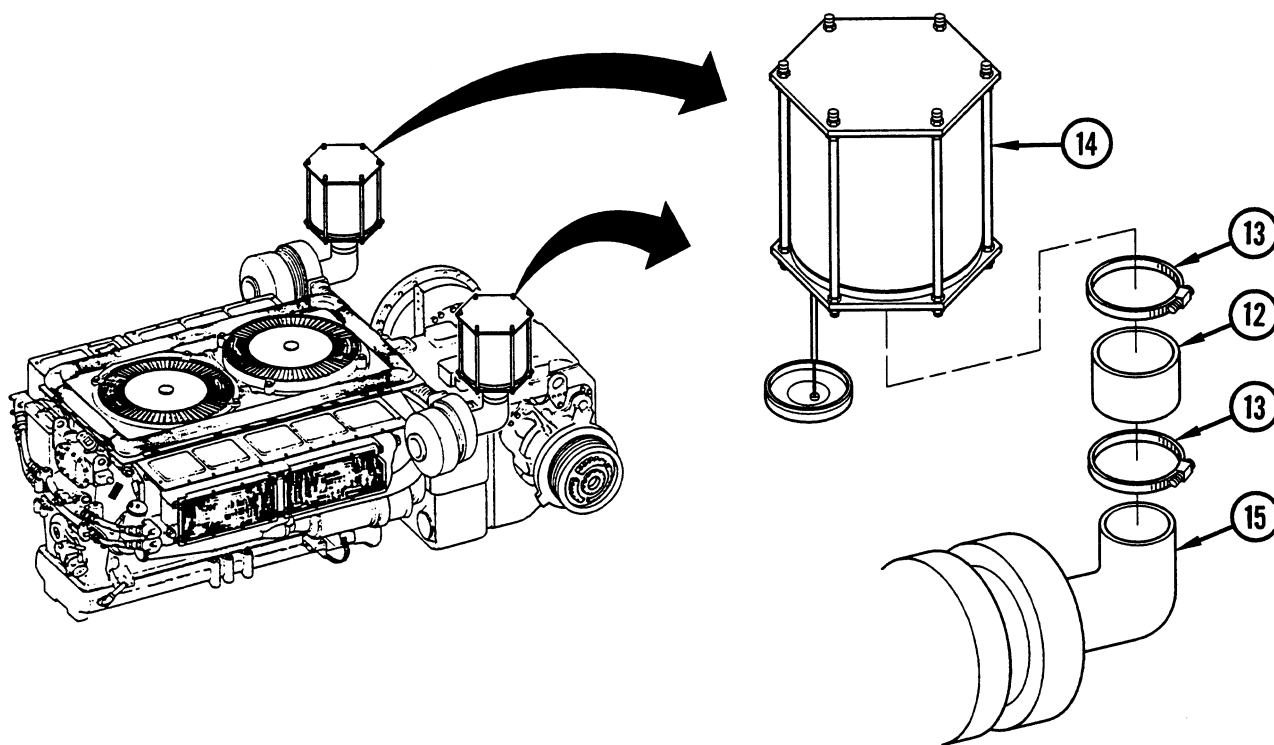

Testing

1. Place throttle control lever (16) and fuel shutoff control lever (17) in open position.

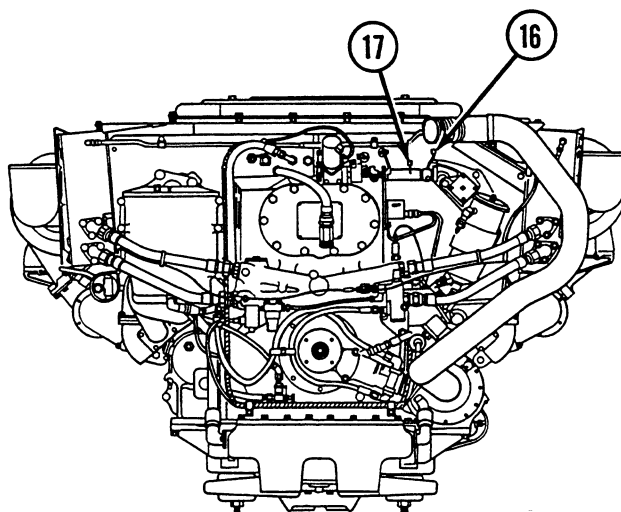

2. Start engine and observe gages, warning lights, and powerplant for proper operation with the aid of assistant.
3. Place throttle control lever (16) at fast idle for 5 seconds. Release and allow powerplant to warm up to 140–240 degrees Fahrenheit ($^{\circ}\text{F}$) (60–116 $^{\circ}$ Celsius [$^{\circ}\text{C}$]). Observe gages and warning lights.
4. Place fuel shutoff control lever (17) in closed position to stop engine.

Removal**NOTE**

Right and left filter assemblies are removed in the same manner.

1. Remove filter assembly (14), two clamps (13), and hose (12) from turbocharger (15).

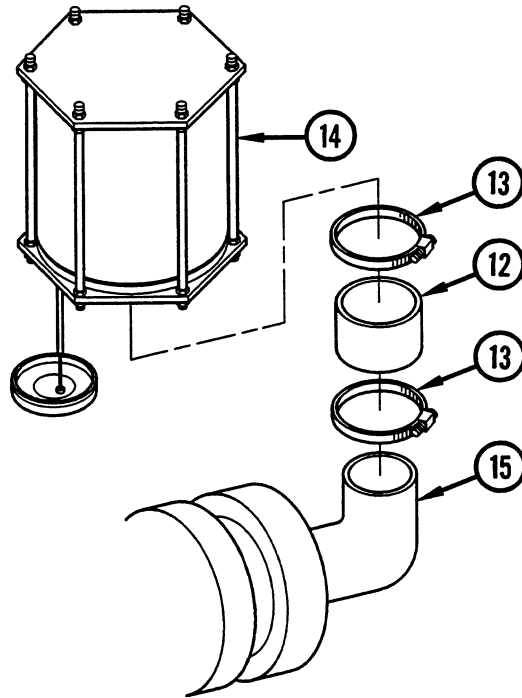

2. Install cover (11) and clamp (10).

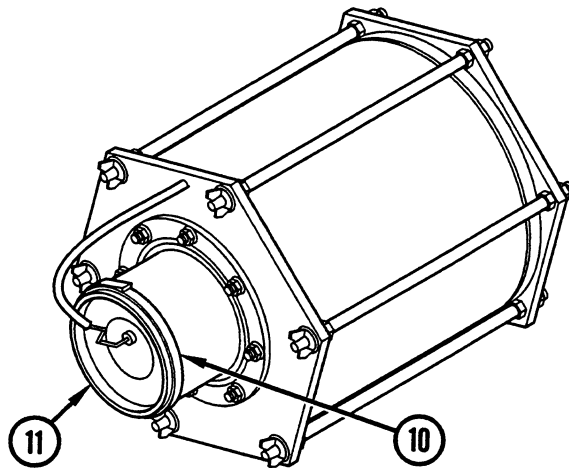

3. Disconnect main fuel hose (9) from quick disconnects in vehicle and on engine.
4. Disconnect primer fuel hose (8) from quick disconnects in vehicle and on engine.
5. Disconnect fuel return hose (7) from quick disconnects in vehicle and on engine.
6. Disconnect accessories cable assembly (4), starter cable assembly (3), ground cable assembly (2), and generator armature cable assembly (1) from vehicle (5) and engine wiring harness bracket (6).

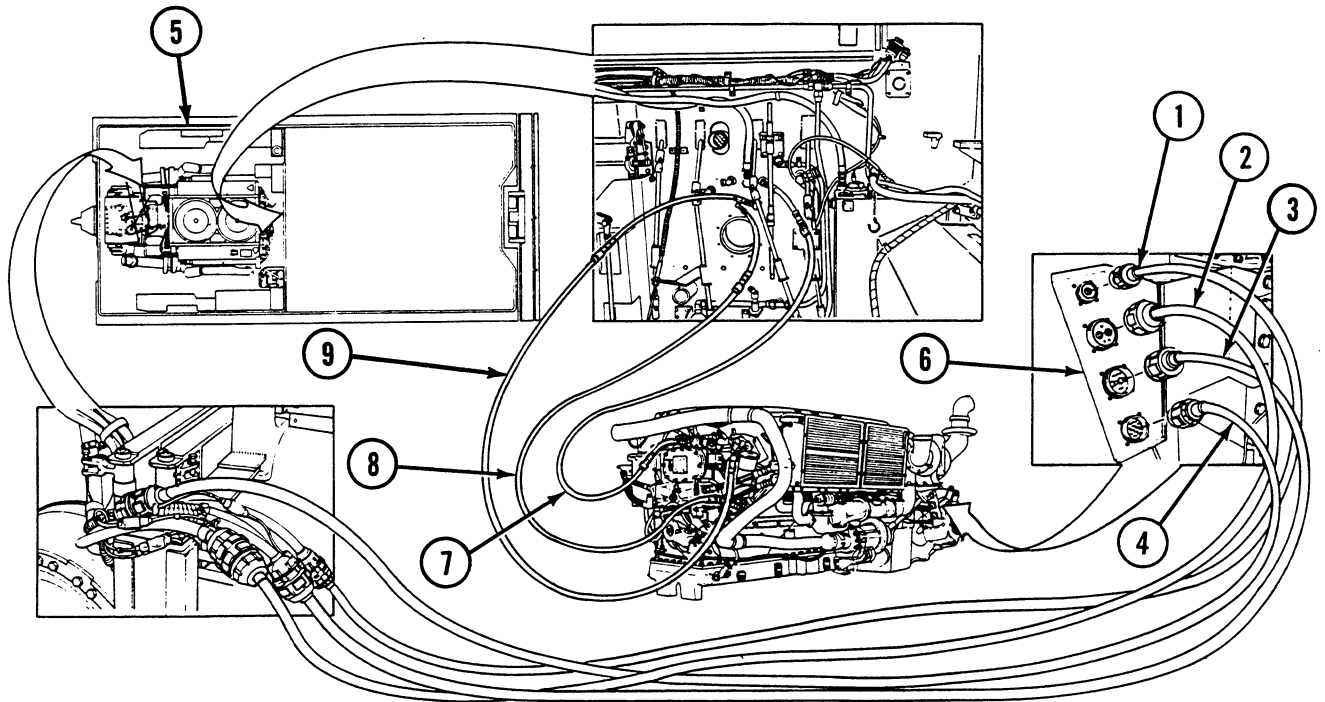

NOTE

Follow-on maintenance: Install powerplant (see WP 0098 00).

END OF WORK PACKAGE

UNIT MAINTENANCE
RECOVERY VEHICLE, FULL TRACKED: MEDIUM, M88A1
NSN 2350-00-122-6826, EIC AQA
EMERGENCY BOOM OPERATION
GENERAL, PREPARATION FOR USE, SERVICING, PLACING IN SERVICE

INITIAL SETUP:**Tools and Special Tools**

Tool kit, general mechanic's (item 59, WP 0490 00)
Hose (item 22, WP 0490 00)
Hose (item 23, WP 0490 00)
Hose (item 24, WP 0490 00)

Materials/Parts

Sealant tape (item 34, WP 0489 00)

References

TM 9-2350-256-10

Equipment Condition

Air grilles removed (see WP 0342 00)
Hydraulic connections access cover removed (see WP 0292 00)
Air cleaner removed (see WP 0138 00)

WARNING

The hoisting boom assembly should NEVER be lifted to the raised position by means of winching the boom with another vehicle. Boom could free-fall resulting in possible death or injury to personnel.

GENERAL

In the event of a power loss to both main engine and auxiliary power unit (APU), the hoisting boom assembly has no RAISE/STOW capabilities. If the boom is in the STOWED position, it is impossible to perform engine deck maintenance.

It should be stressed that removal of the hoisting boom assembly takes about two hours and requires a crane for lifting off, but removal is the best method for performing maintenance from a safety aspect.

Should operation of the boom be considered necessary, the following emergency operation procedure could be applied using an M88A1 Recovery Vehicle as the slaving vehicle.

Assembly and Preparation for Use**CAUTION**

Ensure that both vehicles have the same type of hydraulic fluid.

NOTE

Steps 1 thru 3 apply to the inoperable vehicle.

1. Disconnect hose (1) from hydraulic connections panel port 85 (2).
2. Disconnect hose (3) from quick disconnect (4).
3. Disconnect hose (5) from APU pressure switch (6).

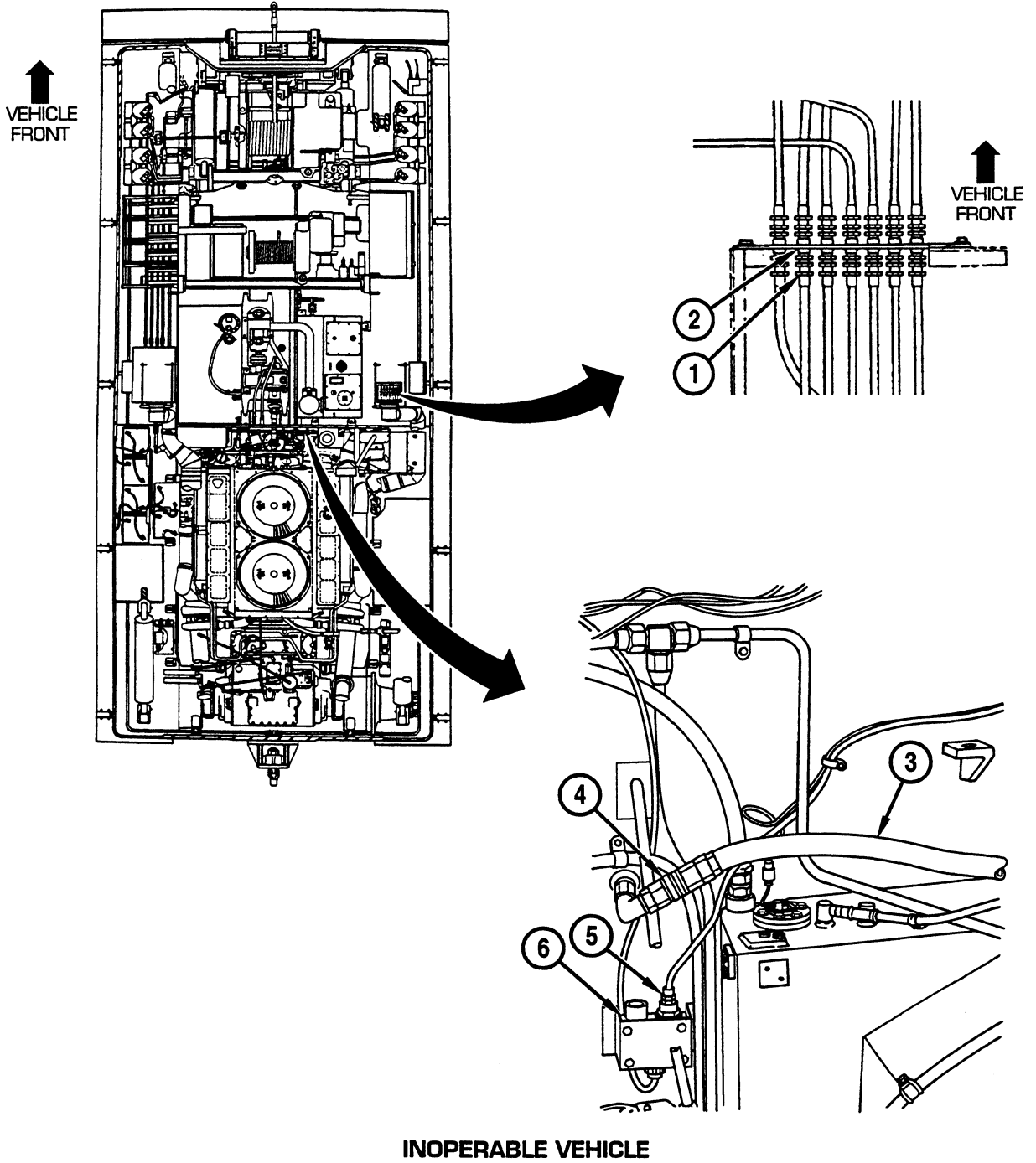

NOTE

Steps 4 thru 6 apply to the slaving vehicle.

4. Disconnect hose (7) from hydraulic connections panel port 85 (8).
5. Disconnect hose (9) from hydraulic pump (10).
6. Disconnect hose (11) from APU pressure switch (12).

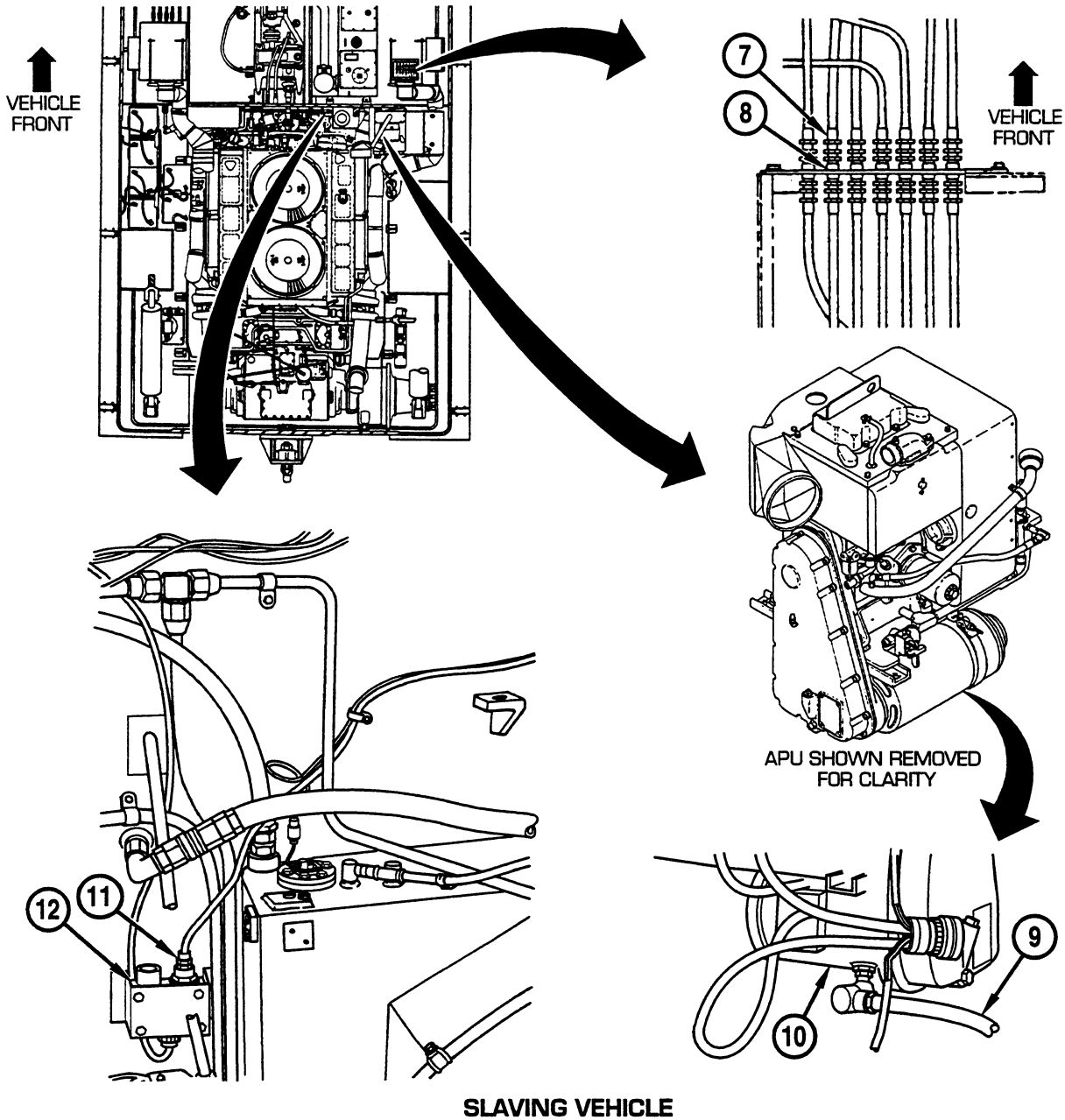

NOTE

Steps 7 thru 9 apply to the inoperable vehicle.

7. Connect hose (13) to port 85 (2) at hydraulic connections panel.
8. Connect hose (14) to quick disconnect (4).
9. Connect hose (15) to APU pressure switch (6).

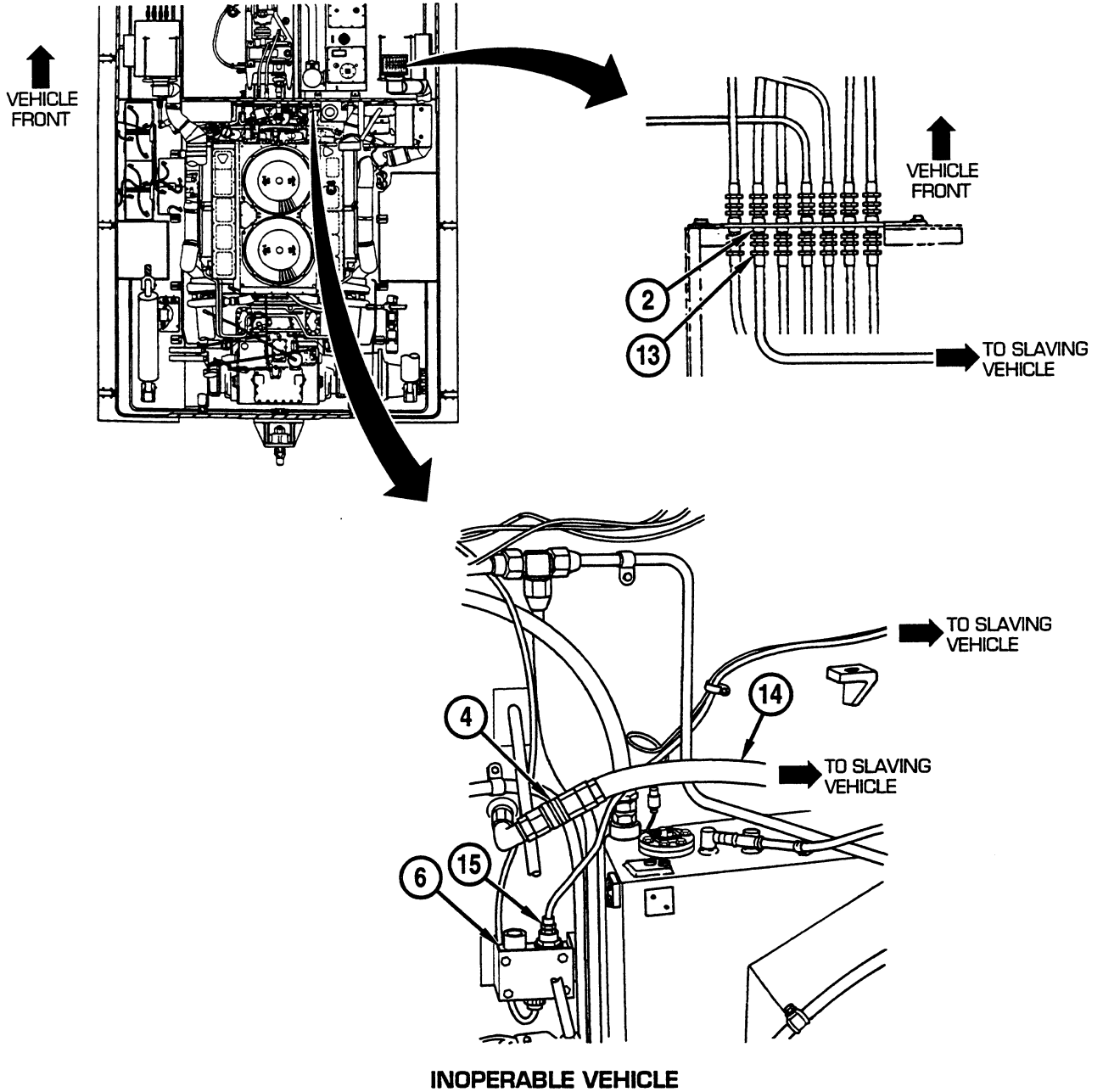

NOTE

Steps 10 thru 12 apply to the slaving vehicle.

- 10. Connect hose (13) to port 85 (8) at hydraulic connections panel.
- 11. Connect hose (14) to hydraulic pump (10).
- 12. Connect hose (15) to APU pressure switch (12).

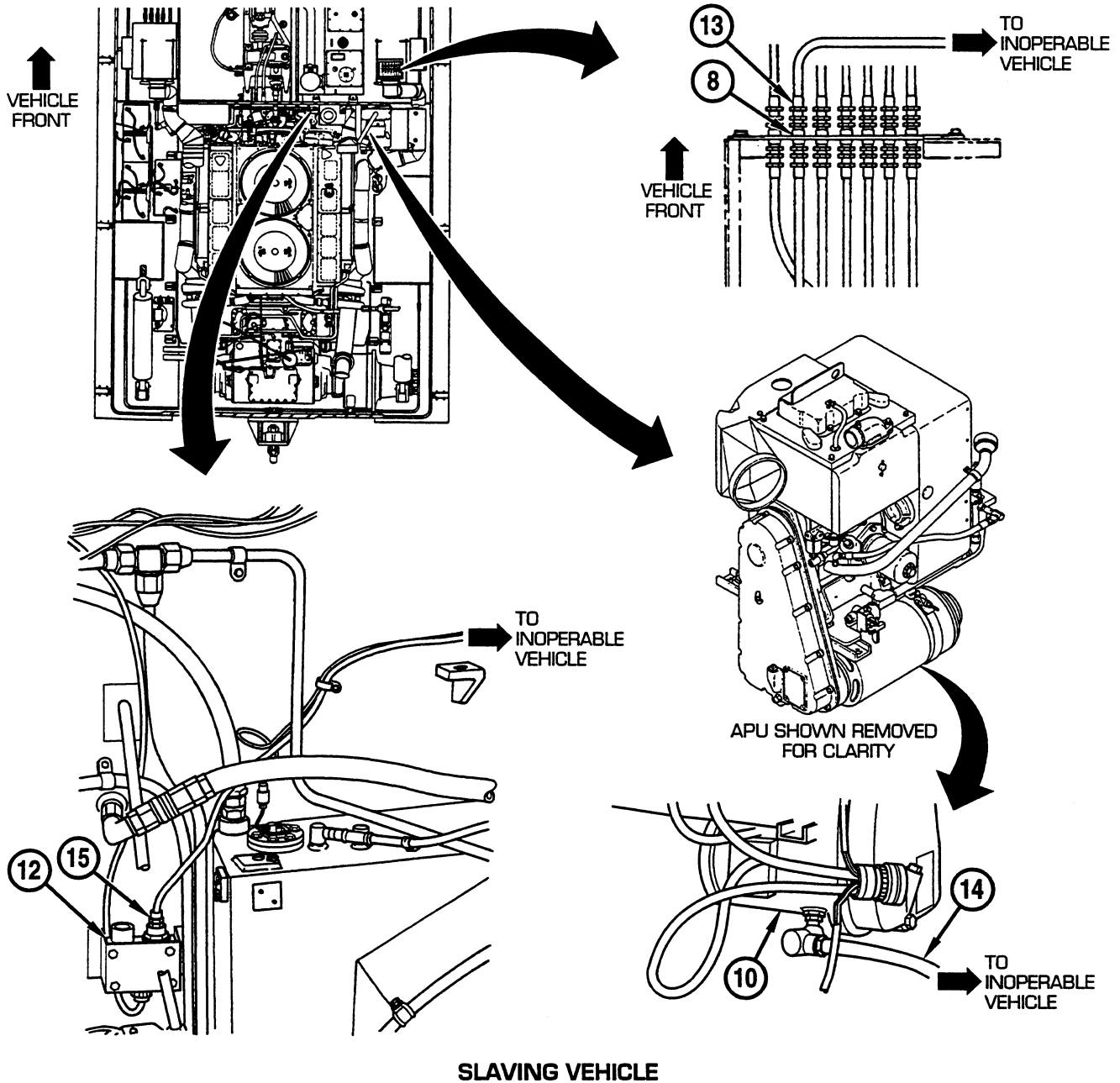

Servicing**WARNING**

Clear all personnel from top and rear areas of vehicles before raising or lowering the boom.

WARNING

Under no circumstances should any hydraulic hoses/lines be disconnected for maintenance purposes unless the boom is in the fully forward position or blocked by boom safety stands.

WARNING

To avoid possibility of injury to personnel, if the hoisting boom cannot be fully raised (roof of building too low, etc.), the use of the safety boom stands is mandatory. After maintenance is performed, when the boom is to be lowered to the stowed position, clear all personnel for the top and rear area of the vehicle.

CAUTION

Always raise the hoisting boom assembly to the fully forward position unless it is not permissible due to an obstruction.

CAUTION

Be sure the AUXILIARY GENERATOR switch on the slaving vehicle is in the OFF position.

CAUTION

Ensure the APU emergency winch operation valve is in the normal operation mode on the inoperable vehicle.

NOTE

The operation (RAISE/LOWER) of the hoisting boom assembly will be completed by using only the controls in the inoperable vehicle, which is being hydraulically driven by the APU of the slaving vehicle.

1. Start APU on slaving vehicle (refer to TM 9-2350-256-10).
2. Shift SYSTEM SELECTOR control lever to auxiliary position and operate hoisting boom controls in inoperable vehicle (refer to TM 9-2350-256-10).

Placing in Service

NOTE

Steps 1 thru 3 apply to the slaving vehicle.

1. Disconnect hose (15) from APU pressure switch (12).
2. Disconnect hose (14) from hydraulic pump (10).
3. Disconnect hose (13) from port 85 (8) at hydraulic connections panel.

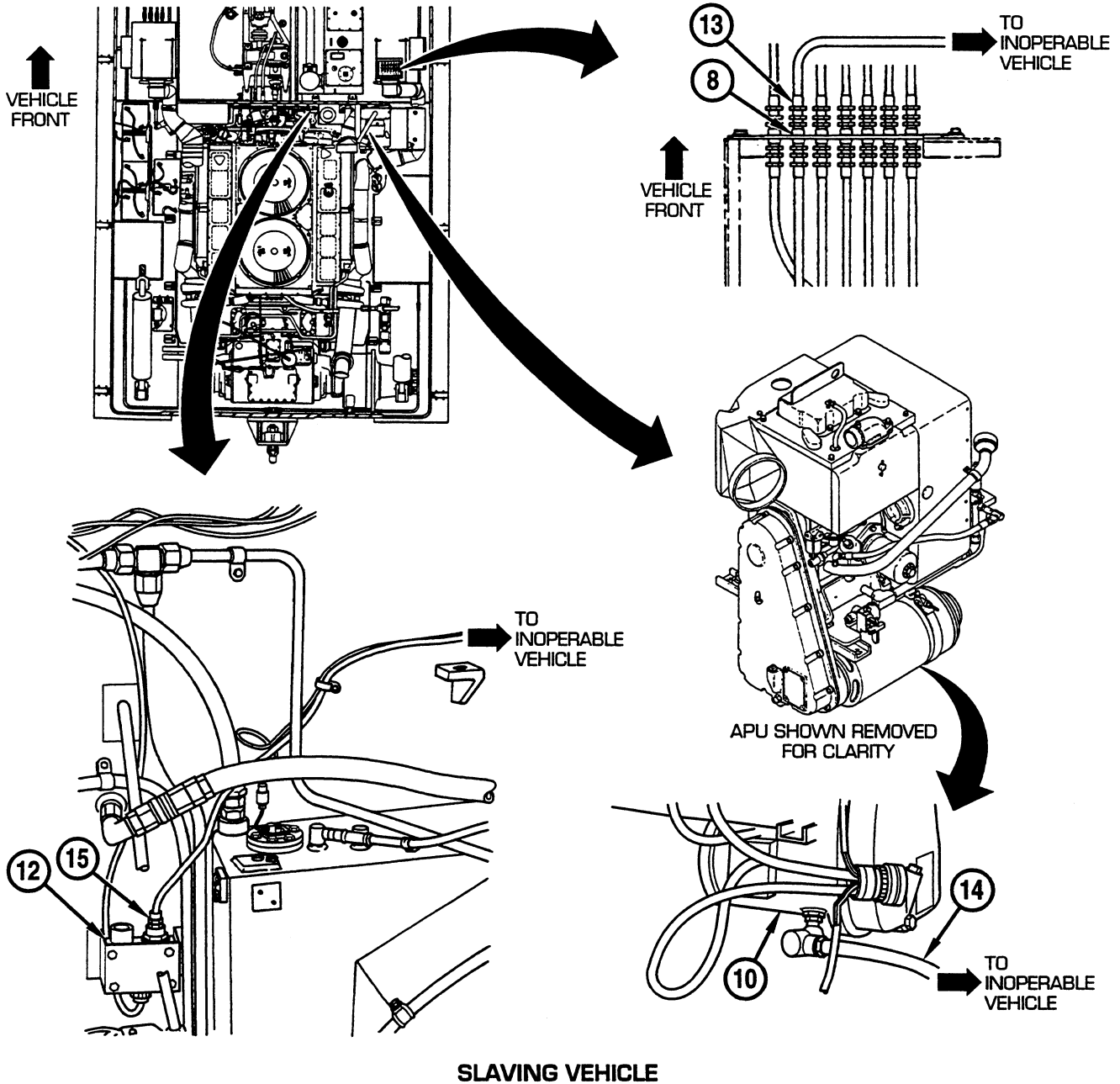

NOTE

Steps 4 thru 6 apply to the inoperable vehicle.

4. Disconnect hose (15) from APU pressure switch (6).
5. Disconnect hose (14) to quick disconnect (4).
6. Disconnect hose (13) from port 85 (2) at hydraulic connections panel.

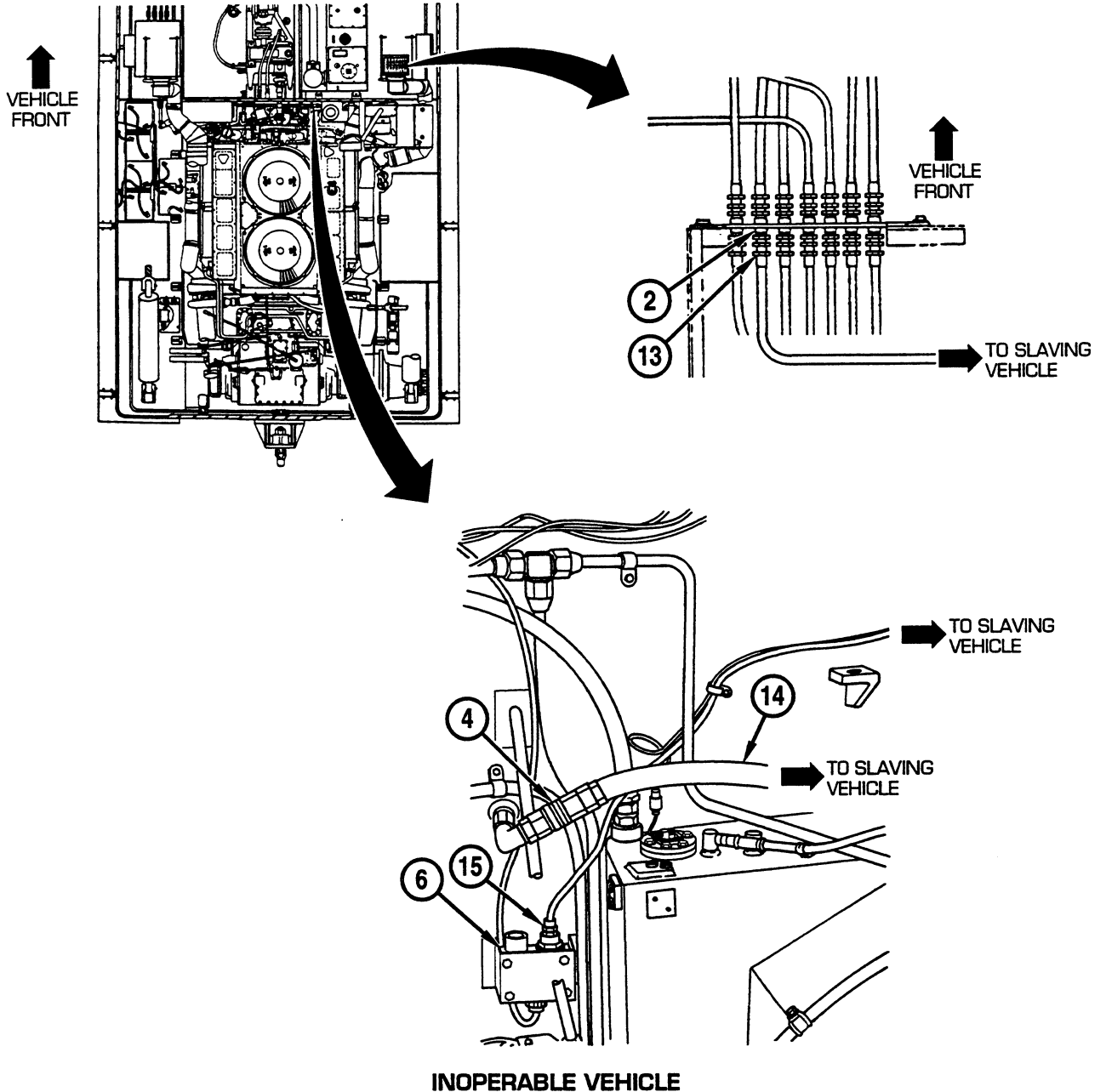

NOTE

Steps 7 thru 9 apply to the slaving vehicle.

7. Connect hose (11) to APU pressure switch (12).
8. Connect hose (9) to hydraulic pump (10).
9. Connect hose (7) to hydraulic connections panel port 85 (8).

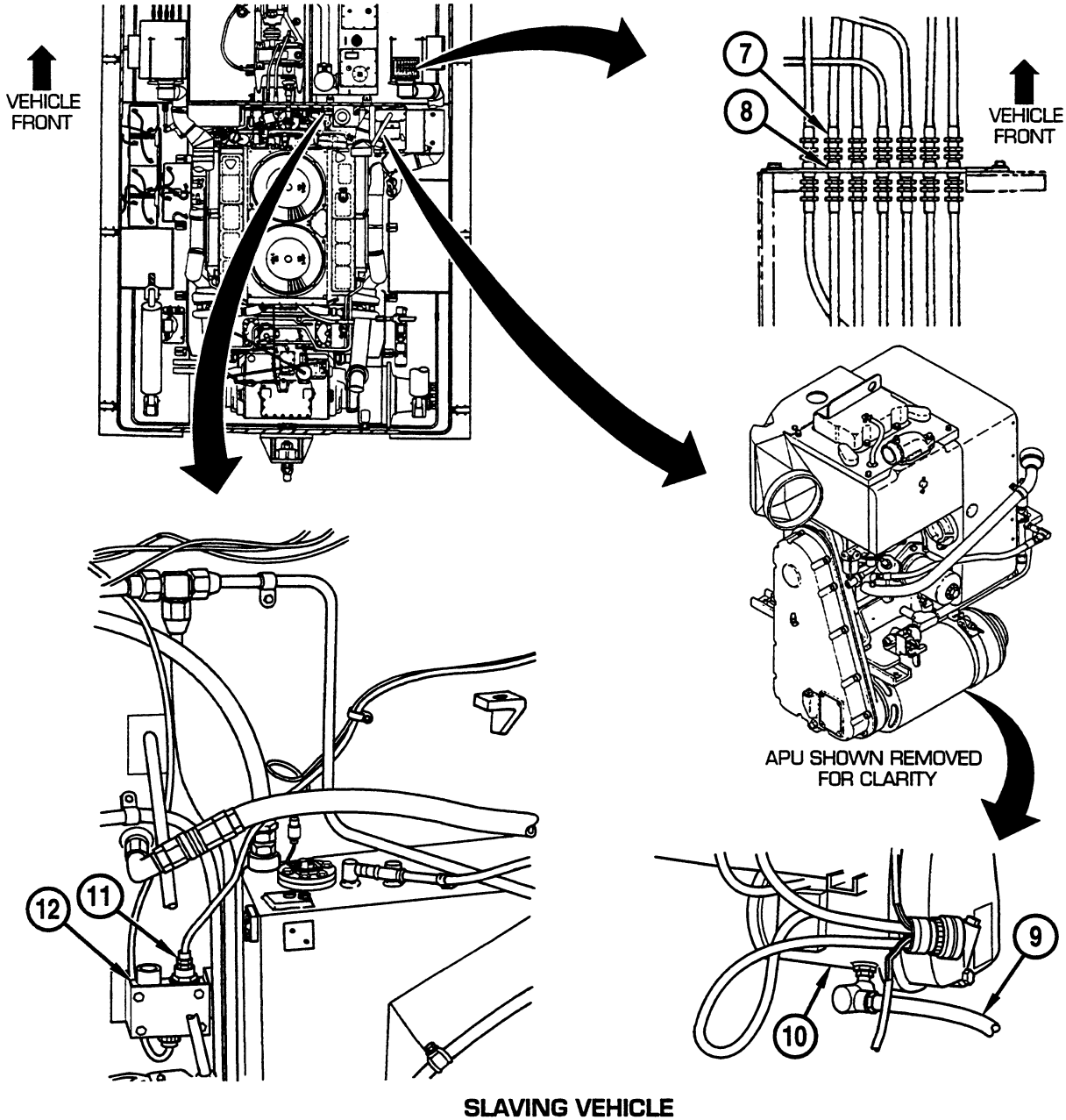

NOTE

Steps 10 thru 12 apply to the inoperable vehicle.

10. Connect hose (5) to APU pressure switch (6).
11. Connect hose (3) to quick disconnect (4).
12. Connect hose (1) to hydraulic connections panel port 85 (2).

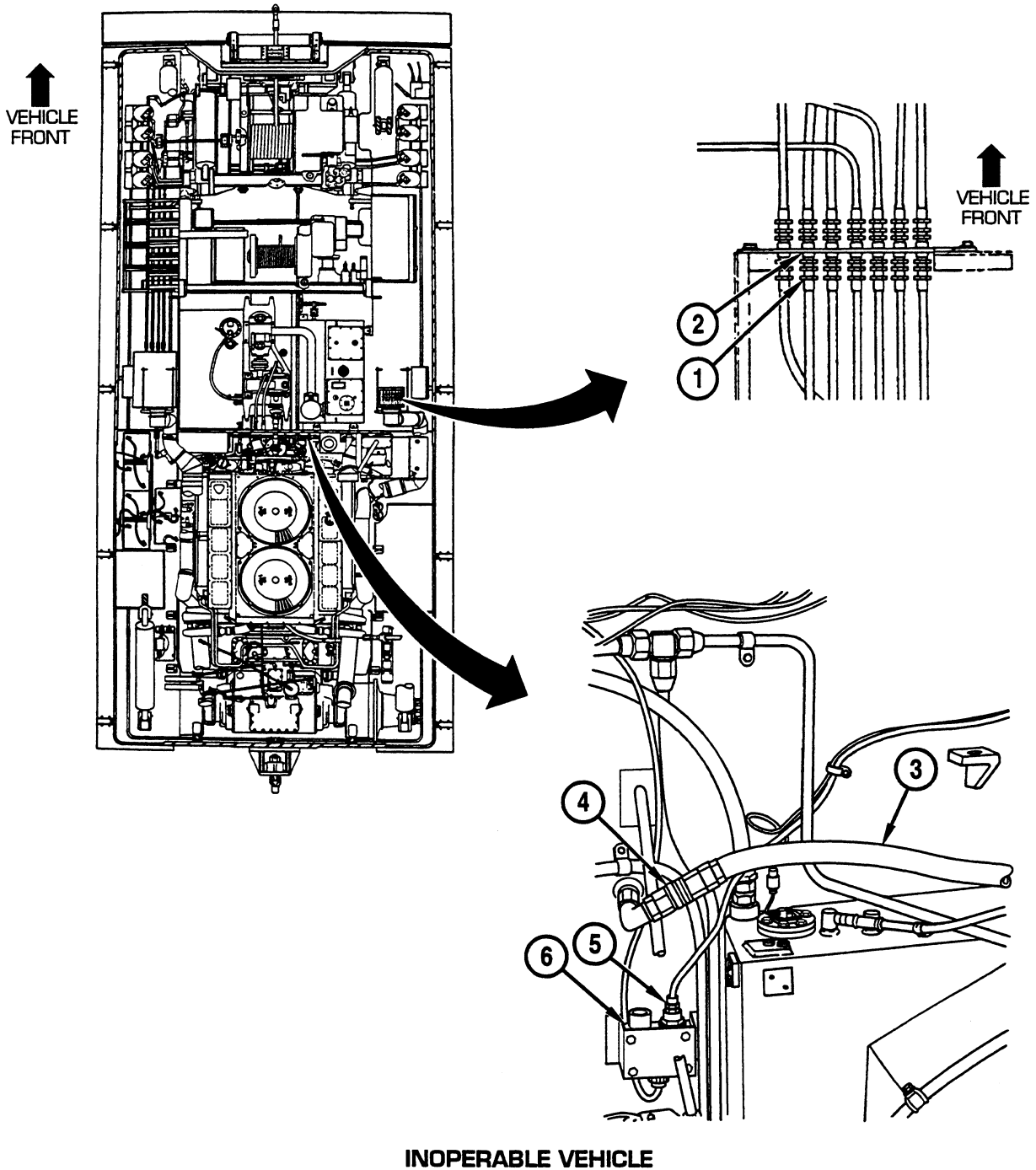

NOTE

Follow-on maintenance: Install air cleaner (see WP 0138 00); Install hydraulic connections across cover (see WP 0292 00); Install air inlet grilles (see WP 0342 00).

END OF WORK PACKAGE

UNIT MAINTENANCE
RECOVERY VEHICLE, FULL TRACKED: MEDIUM, M88A1
NSN 2350-00-122-6826, EIC AQA

ENGINE MOUNTING BRACKET MAINTENANCE
REMOVAL, DISASSEMBLY, ASSEMBLY, INSTALLATION

INITIAL SETUP:**Tools and Special Tools**

Tool kit, general mechanic's (item 59, WP 0490 00)
Multiplier, torque (item 33, WP 0490 00)
Socket set (item 54, WP 0490 00)
Wrench, torque (item 69, WP 0490 00)

Materials/Parts

Nuts, self-locking (4) (item 434, WP 0491 00)
Nuts, self-locking (8) (item 742, WP 0491 00)
Screws (6) (item 18, WP 0491 00)

Materials/Parts (cont.)

Screws (4) (item 422, WP 0491 00)
Screws (2) (item 872, WP 0491 00)
Washers, flat (6) (item 543, WP 0491 00)

Personnel Required

Mechanics (2)

Equipment Condition

Powerplant removed (see WP 0098 00)

Removal

1. Remove engine mount assembly (1) from engine (2) by removing six self-locking nuts (3), six flat washers (4), and six screws (5).
2. Remove saddle assembly (6) from engine mount (7) by removing two screws (8) and two self-locking nuts (9).

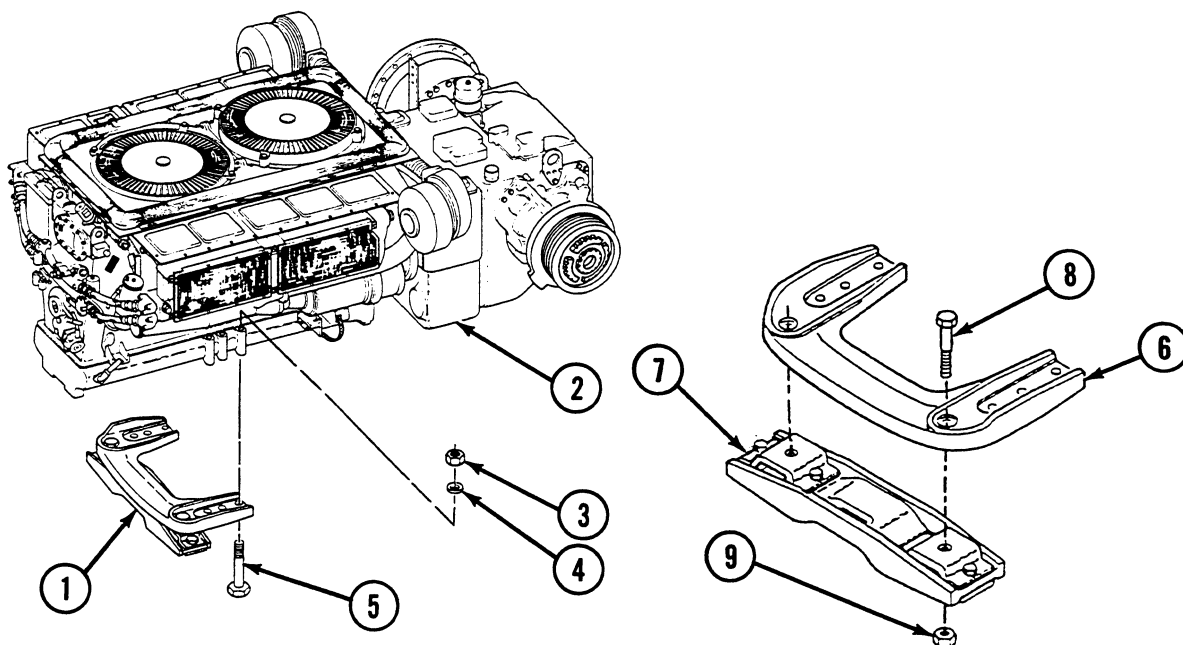

Disassembly

1. Remove four self-locking nuts (10), four screws (11), and four mounts (12).
2. Remove two shims (13) and two spacers (14) from saddle (15).

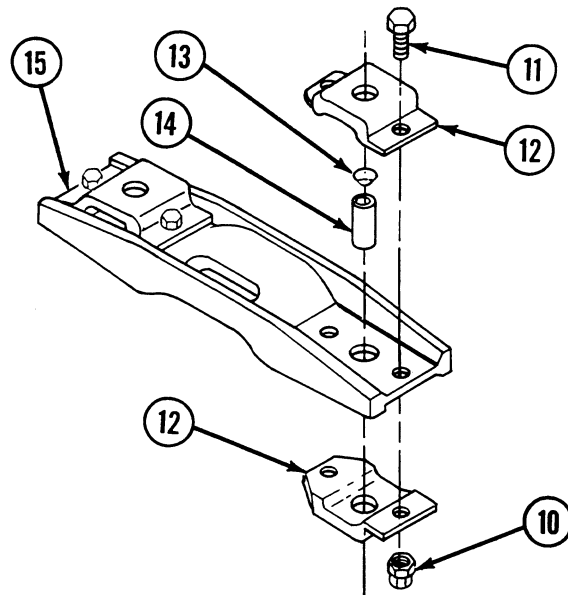
**Assembly****NOTE**

Mounts are to be assembled with a total of $0.030 + 0.015$ in. ($0.7620 + 0.3810$ mm) of precompression clearance. Shim if required.

1. Install two spacers (14) and two shims (13) to saddle (15).
2. Install four mounts (12) with four screws (11) and four self-locking nuts (10).

Installation

1. Install saddle assembly (6) to engine mount (7) with two screws (8) and two self-locking nuts (9).
2. Install engine mount assembly (1) to engine (2) with six screws (5), six flat washers (4), and six self-locking nuts (3). Torque self-locking nuts to 250–280 lb-ft (339–380 N•m).

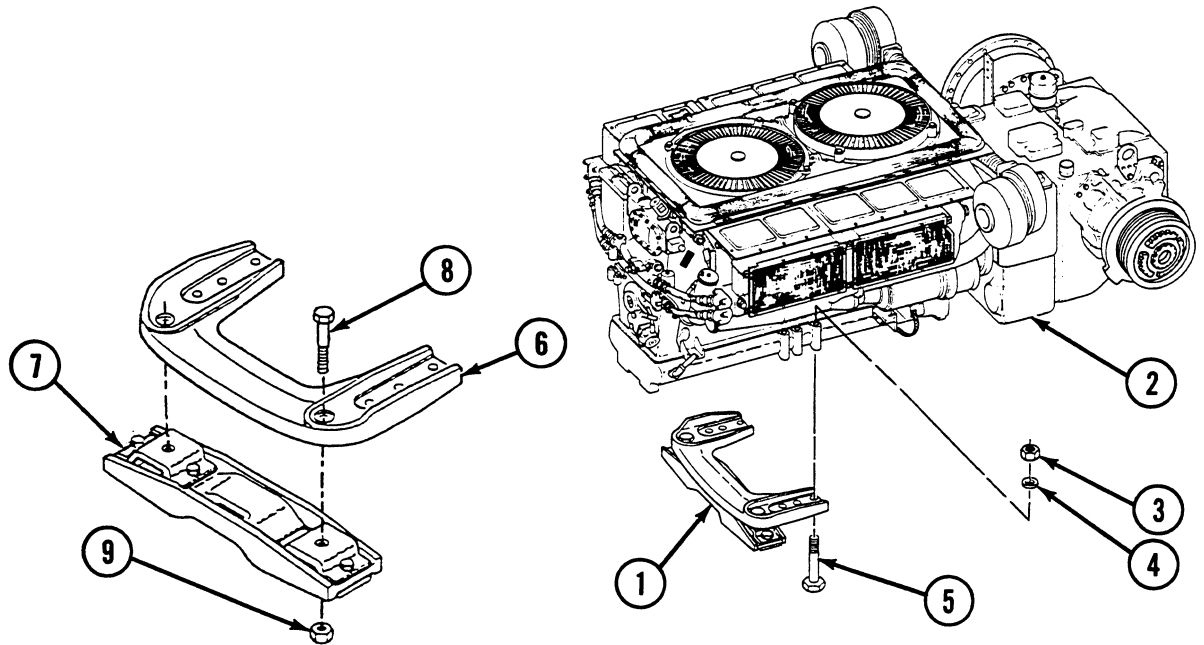
**NOTE**

Follow-on maintenance: Install powerplant (see WP 0098 00).

END OF WORK PACKAGE

UNIT MAINTENANCE
RECOVERY VEHICLE, FULL TRACKED: MEDIUM, M88A1
NSN 2350-00-122-6826, EIC AQA
ENGINE REAR MOUNT AND BASE ASSEMBLY REPLACEMENT
REMOVAL, INSTALLATION

INITIAL SETUP:**Tools and Special Tools**

Tool kit, general mechanic's (item 59, WP 0490 00)

Materials/Parts

Keys (2) (item 187, WP 0491 00)
Lockwashers (3) (item 638, WP 0491 00)
Lockwashers (8) (item 640, WP 0491 00)
Lockwashers (4) (item 653, WP 0491 00)
Nuts (3) (item 763, WP 0491 00)
Pins, cotter (8) (item 108, WP 0491 00)
Pins, straight (4) (item 260, WP 0491 00)

Materials/Parts (cont.)

Pins, straight (4) (item 267, WP 0491 00)
Screws (4) (item 402, WP 0491 00)
Screws (2) (item 421, WP 0491 00)
Screws (2) (item 787, WP 0491 00)
Screws (4) (item 800, WP 0491 00)
Screws (3) (item 811, WP 0491 00)
Setscrews (2) (item 752, WP 0491 00)

Equipment Condition

Powerplant removed (see WP 0098 00)

Removal

1. Remove horizontal shaft (1) from universal joints (2 and 3) at each end of shaft by removing two cotter pins (4) and two straight pins (5).
2. Remove universal joint (2) from base assembly (6) by removing cotter pin (7) and straight pin (8).
3. Remove base assembly (6) by removing four screws (9) and four lockwashers (10).
4. Remove shaft (11) from universal joints (12 and 13) at each end of shaft by removing two cotter pins (14) and two straight pins (15).
5. Remove drive assembly (16) by removing three screws (17), three lockwashers (18), and three nuts (19).

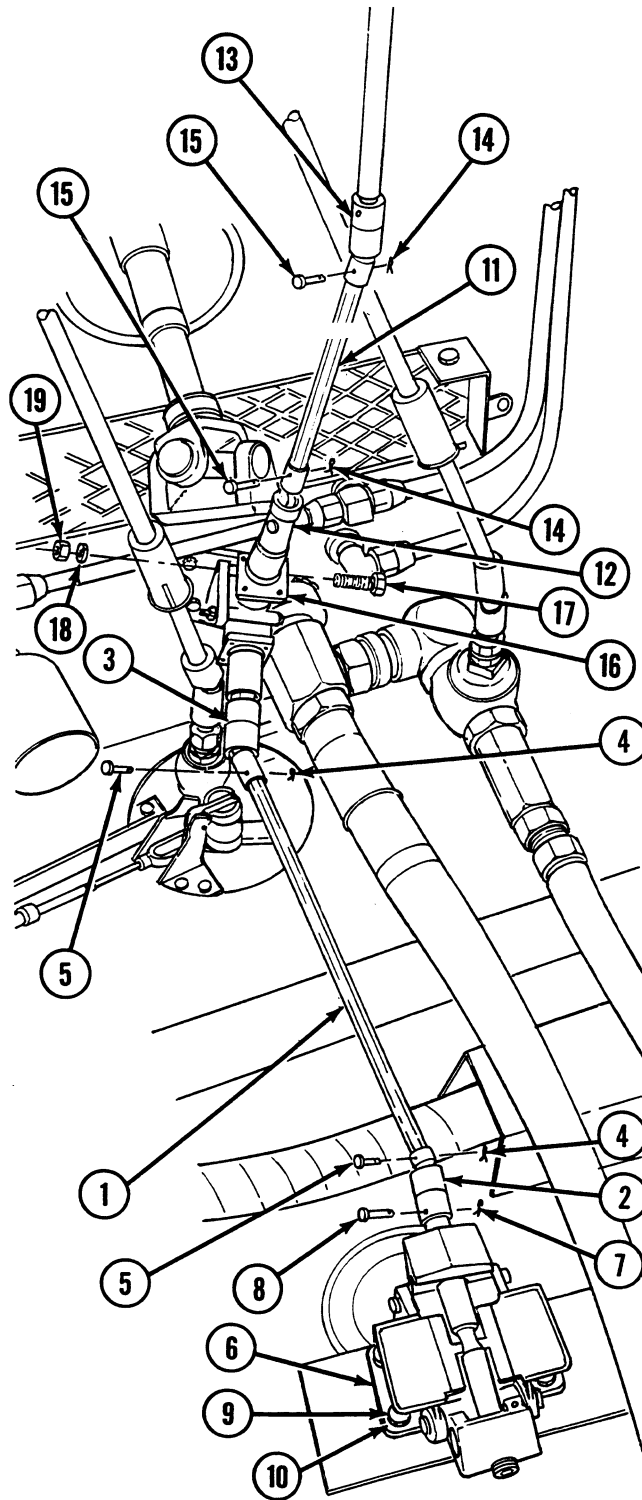

6. Remove two universal joints (3 and 12) from drive assembly (16) by removing two cotter pins (20) and two straight pins (21).
7. Remove two couplings (22) from drive assembly (16) by removing two setscrews (23).
8. Remove two keys (24) from drive assembly (16).

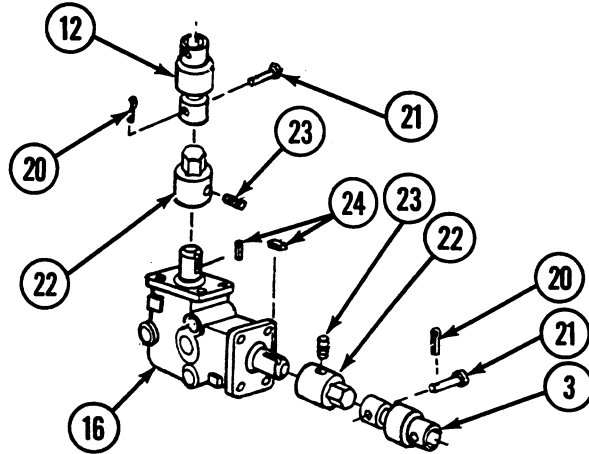

9. Remove universal joint (13) from vertical shaft (25) by removing cotter pin (26) and straight pin (27).
10. Loosen collar (28) and remove vertical shaft (25).

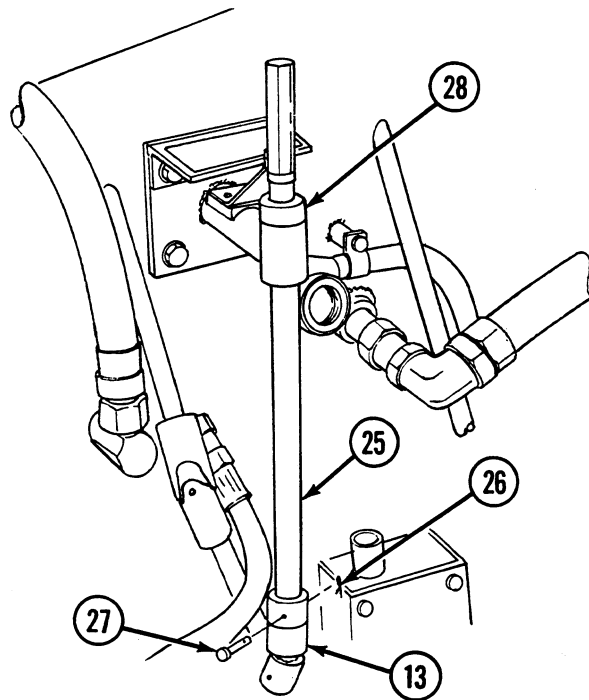

11. Remove ID plate (29) and bracket (30) by removing four screws (31) and four lockwashers (32).

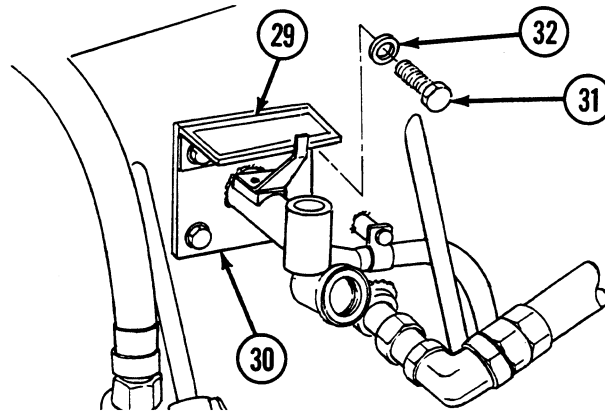

12. Remove drive assembly bracket (33) by removing four screws (34) and four lockwashers (35).

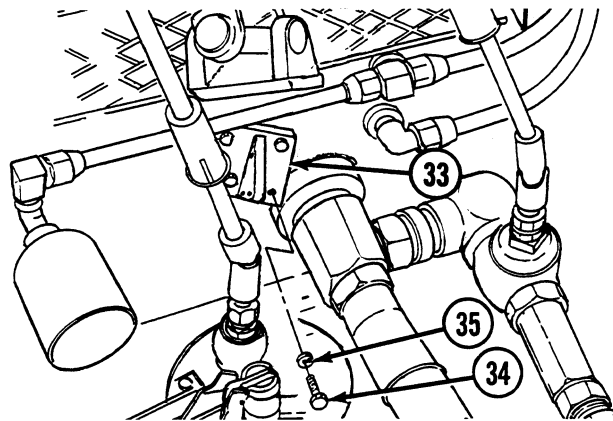

Installation

1. Install drive assembly bracket (33) with four screws (34) and four lockwashers (35).
2. Install ID plate (29) and bracket (30) with four screws (31) and four lockwashers (32).
3. Install vertical shaft (25) and tighten collar (28).
4. Install universal joint (13) on vertical shaft (25) with straight pin (27) and cotter pin (26).
5. Install two keys (24) to drive assembly (16).
6. Install two couplings (22) to drive assembly (16) with two setscrews (23).

7. Install two universal joints (3 and 12) to drive assembly (16) with two straight pins (21) and two cotter pins (20).
8. Install drive assembly (16) with three screws (17), three lockwashers (18), and three nuts (19).
9. Install shaft (11) to two universal joints (12 and 13) with two straight pins (15) and two cotter pins (14).
10. Install base assembly (6) with four lockwashers (10) and four screws (9).
11. Install universal joint (2) to base assembly (6) with straight pin (8) and cotter pin (7).
12. Install horizontal shaft (1) to universal joints (2 and 3) with two straight pins (5) and two cotter pins (4).

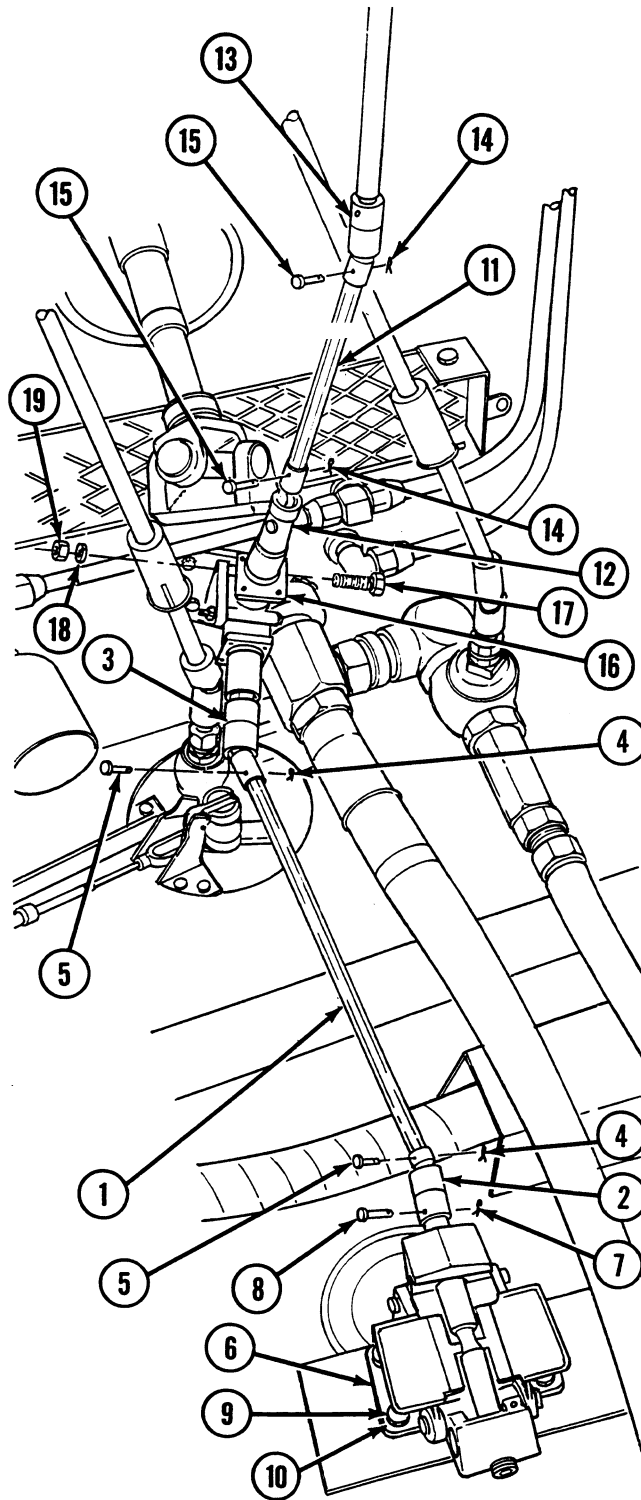

NOTE

Follow-on maintenance: Install powerplant (see WP 0098 00).

END OF WORK PACKAGE

UNIT MAINTENANCE
RECOVERY VEHICLE, FULL TRACKED: MEDIUM, M88A1
NSN 2350-00-122-6826, EIC AQA
ENGINE OIL FILTER SERVICING INSTRUCTION PLATE REPLACEMENT
REMOVAL, INSTALLATION

INITIAL SETUP:**Tools and Special Tools**

Tool kit, general mechanic's (item 59, WP 0490 00)

Equipment Condition

Grille doors removed (see WP 0342 00)

Materials/Parts

Drivescrews (4) (item 500, WP 0491 00)

Removal

1. Remove instruction plate (1) from bracket (2) by removing four drivescrews (3).

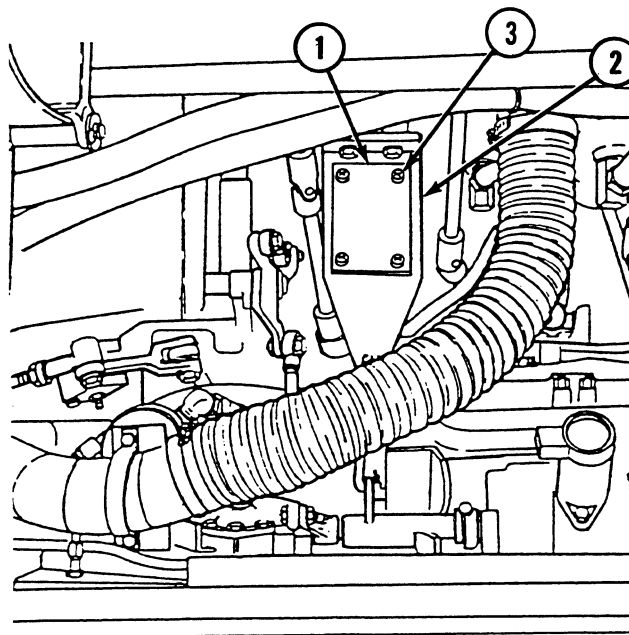
**Installation**

1. Install instruction plate (1) to bracket (2) with four drivescrews (3).

NOTE

Follow-on maintenance: Install grille doors (see WP 0342 00).

END OF WORK PACKAGE

UNIT MAINTENANCE
RECOVERY VEHICLE, FULL TRACKED: MEDIUM, M88A1
NSN 2350-00-122-6826, EIC AQA

ENGINE DAMPER HOUSING, OIL FILTER, AND RELATED PARTS MAINTENANCE
REMOVAL, CLEANING, INSTALLATION

INITIAL SETUP:**Tools and Special Tools**

Tool kit, general mechanic's (item 59, WP 0490 00)
Bolts, machine (2) (jackscrews) (item 4, WP 0490 00)
Pliers, retaining ring, external (item 38, WP 0490 00)

Materials/Parts

Nuts, self-locking (10) (item 496, WP 0491 00)
Packings (2) (item 103, WP 0491 00)
Packing, preformed (item 437, WP 0491 00)
Parts kit (item 185, WP 0491 00)

Materials/Parts (cont.)

Rings, retaining (2) (item 454, WP 0491 00)
Screw (item 402, WP 0491 00)
Springs (2) (item 104, WP 0491 00)
Washers (2) (item 102, WP 0491 00)
Washers, flat (11) (item 834, WP 0491 00)

Equipment Condition

Grille doors removed (see WP 0336 00)

Removal

1. Remove oil vent screw (1), flat washer (2), and packing (3).

NOTE

Do not loosen oil drain valve adapter (4).

2. Loosen oil drain valve plug (5) by turning 6 complete revolutions.
3. Remove main fuel hose (6) from clamp (7).
4. Remove 10 self-locking nuts (8), 10 flat washers (9), and clamp (7).

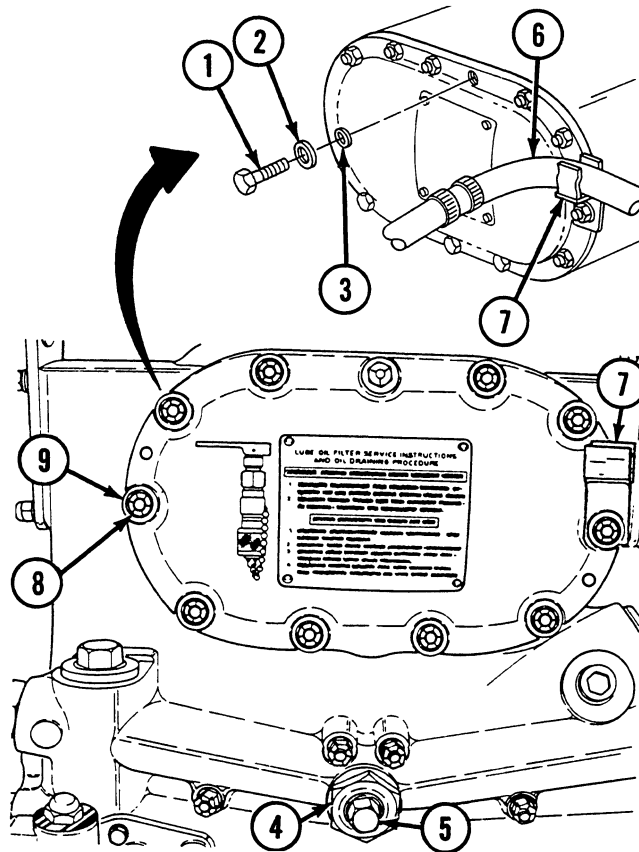

5. Install two jackscrews (10) in oil filter cover (11).
6. Remove oil filter cover (11) using two jackscrews (10) for support.
7. Remove gasket (12).
8. Remove oil drain valve (13), oil drain valve plug (5), or preformed packing (14) if necessary.

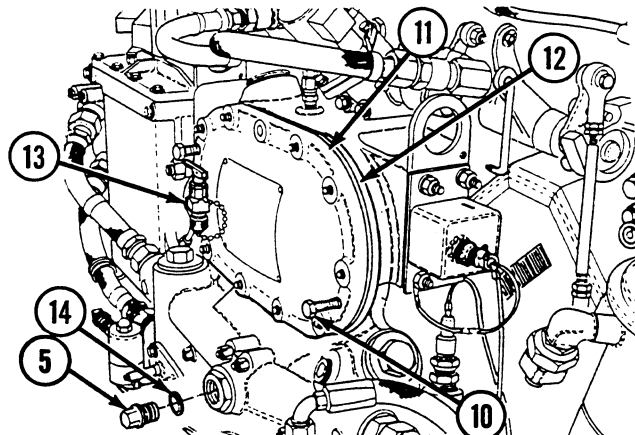

9. Remove and discard two oil filter elements (15).

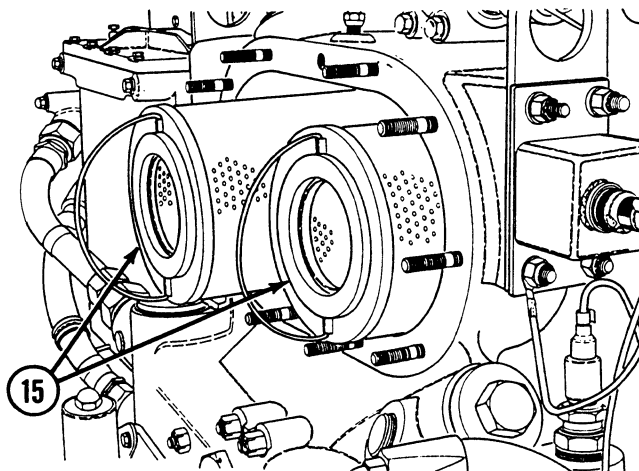

10. Remove two retaining rings (16), two packings (17), and two filter bodies (18).
11. Remove two washers (19), two springs (20), and two oil filter supports (21).

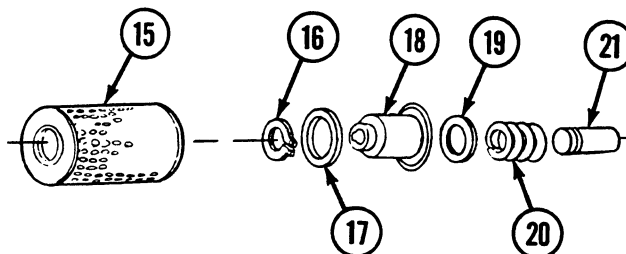

Cleaning

1. Clean filter bodies (18) with clean, lint-free cloth. Be careful not to drop foreign particles into drain holes.

Installation

1. Install two oil filter supports (21), two springs (20), and two washers (19).
2. Install two filter bodies (18), two packings (17), and two retaining rings (16).

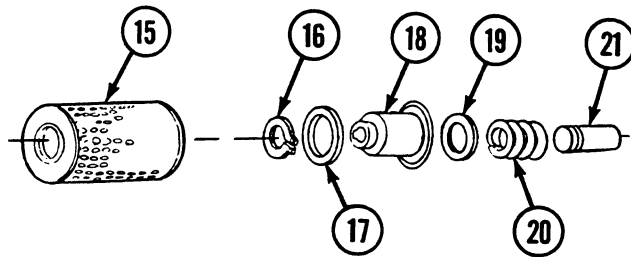

3. Install two oil filter elements (15).

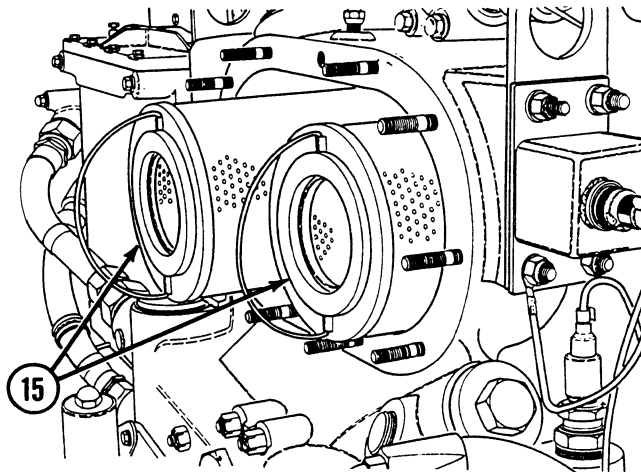

4. Install gasket (12) under oil filter cover (11).

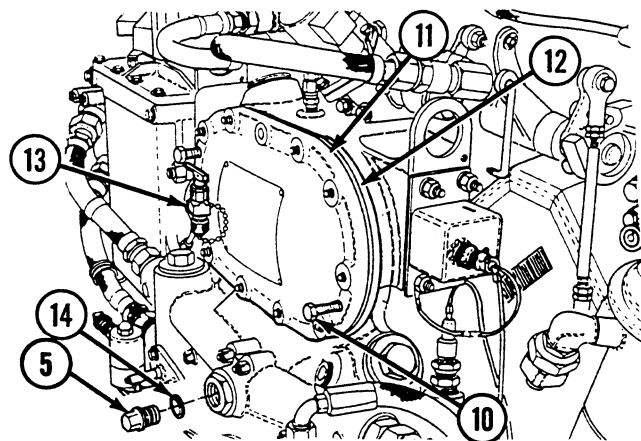

5. Secure oil filter cover (11) with 10 self-locking nuts (8), 10 flat washers (9), and clamp (7).
6. Install main fuel hose (6) to clamp (7).
7. Install preformed packing (14) and oil drain valve plug (5) if removed.
8. Install oil drain valve (13) if removed.

CAUTION

Failure to tighten oil drain valve plug until it bottoms will result in loss of engine oil pressure.

9. Tighten oil drain valve plug (5) until it bottoms.
10. Install oil vent screw (1), flat washer (2), and packing (3).

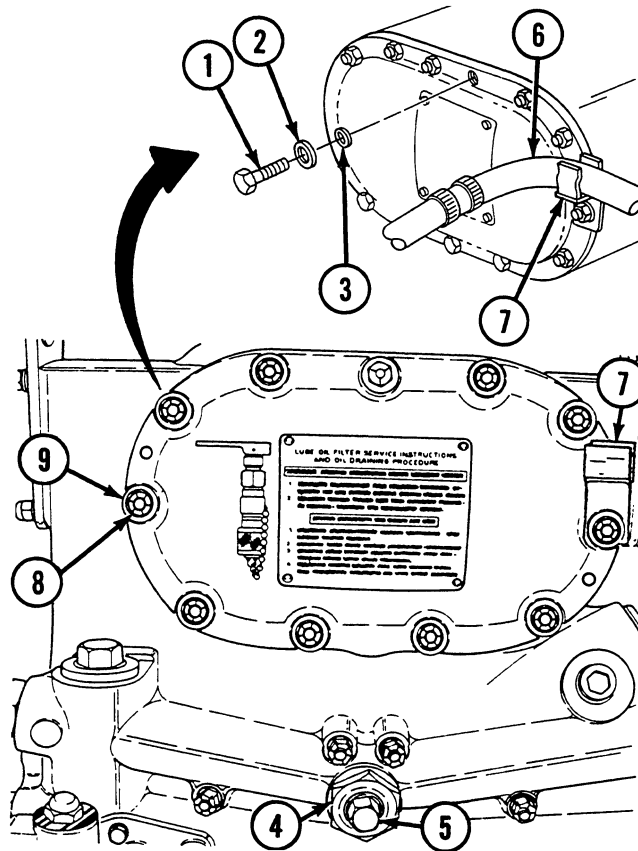

NOTE

Follow-on maintenance: Install grille doors (see WP 0336 00).

END OF WORK PACKAGE

UNIT MAINTENANCE
RECOVERY VEHICLE, FULL TRACKED: MEDIUM, M88A1
NSN 2350-00-122-6826, EIC AQA
OIL LEVEL INDICATOR AND RELATED PARTS REPLACEMENT
REMOVAL, INSTALLATION

INITIAL SETUP:**Tools and Special Tools**

Tool kit, general mechanic's (item 59, WP 0490 00)

Materials/Parts

Drivescrews (2) (item 502, WP 0491 00)
 Gasket (item 64, WP 0491 00)
 Gasket (item 188, WP 0491 00)
 Lockwashers (2) (item 639, WP 0491 00)
 Nuts, self-locking (3) (item 491, WP 0491 00)
 Packings, preformed (2) (item 438, WP 0491 00)
 Screws (12) (item 256, WP 0491 00)

Materials/Parts (cont.)

Screws (2) (item 791, WP 0491 00)
 Washers, flat (2) (item 443, WP 0491 00)

References

TM 9-2350-256-10

Equipment Condition

Powerplant removed (see WP 0098 00)
 Engine oil drained

Removal

1. Remove oil level gage rod (1).

NOTE

Oil level indicator tube cap assembly (2) is removed with right front upper cover (3).

2. Remove right front upper cover (3) and strap (4) by removing 12 screws (5).

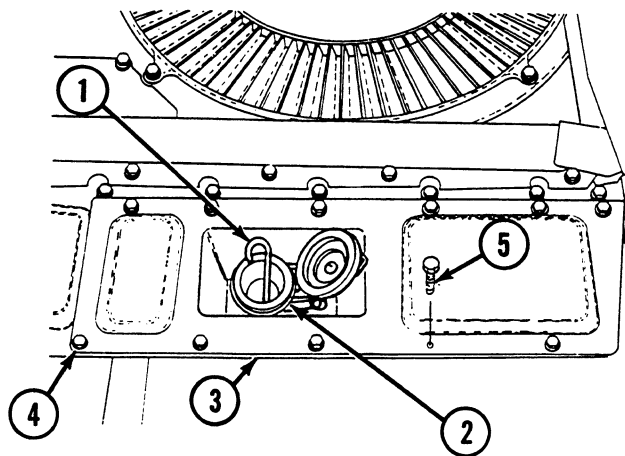

3. Remove oil level indicator tube cap assembly (2) from right front upper cover (3) by removing two screws (6) and two lockwashers (7).
4. Remove gasket (8) and two preformed packings (9) from oil level indicator tube cap assembly (2).
5. Remove ID plate (10) by removing two drivescrews (11) and two flat washers (12).

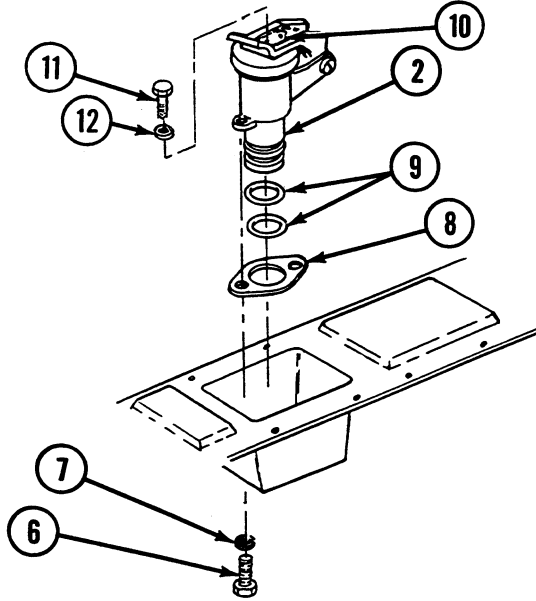

6. Remove oil level indicator tube (13) by removing three self-locking nuts (14) and gasket (15).

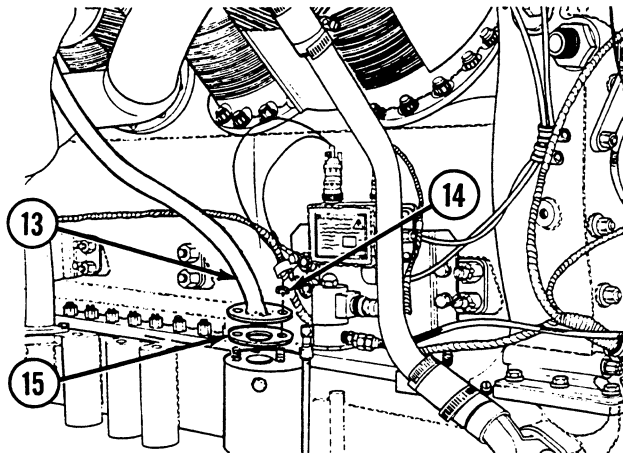

Installation

1. Install oil level indicator tube (13) with three self-locking nuts (14) and gasket (15).
2. Install ID plate (10) with two drivescrews (11) and two flat washers (12) to oil level indicator tube cap assembly (2).
3. Install gasket (8) with two preformed packings (9) onto oil level indicator tube cap assembly (2).
4. Install oil level indicator tube cap assembly (2) on right front upper cover (3) with two screws (6) and two lockwashers (7).
5. Install right front upper cover (3) and strap (4) with 12 screws (5).
6. Install oil level gage rod (1).

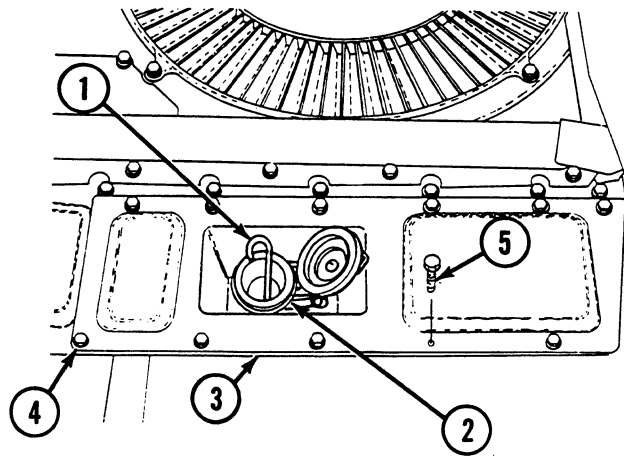

7. Replace engine oil (refer to TM 9-2350-256-10).

NOTE

Follow-on maintenance: Install powerplant (see WP 0098 00).

END OF WORK PACKAGE

UNIT MAINTENANCE
RECOVERY VEHICLE, FULL TRACKED: MEDIUM, M88A1
NSN 2350-00-122-6826, EIC AQA

OIL FILLER TUBE AND RELATED PARTS REPLACEMENT
REMOVAL, INSTALLATION

INITIAL SETUP:**Tools and Special Tools**

Tool kit, general mechanic's (item 59, WP 0490 00)

Materials/Parts

Clamps (2) (item 714, WP 0491 00)
 Drivescrews (2) (item 502, WP 0491 00)
 Gasket (item 188, WP 0491 00)
 Lockwashers (2) (item 639, WP 0491 00)
 Nuts, self-locking (2) (item 492, WP 0491 00)
 Nuts, self-locking (2) (item 852, WP 0491 00)
 Packings (3) (item 66, WP 0491 00)
 Screw (item 398, WP 0491 00)
 Screw (item 399, WP 0491 00)

Materials/Parts (cont.)

Screws (2) (item 401, WP 0491 00)
 Screws (2) (item 607, WP 0491 00)
 Screws (3) (item 816, WP 0491 00)
 Washers (2) (item 271, WP 0491 00)
 Washers, flat (2) (item 443, WP 0491 00)

References

TM 9-2350-256-10

Equipment Condition

Powerplant removed (see WP 0098 00)
 Engine oil drained

Removal

1. Remove lower oil fill tube (1) by removing three screws (2), three packings (3), and gasket (4).

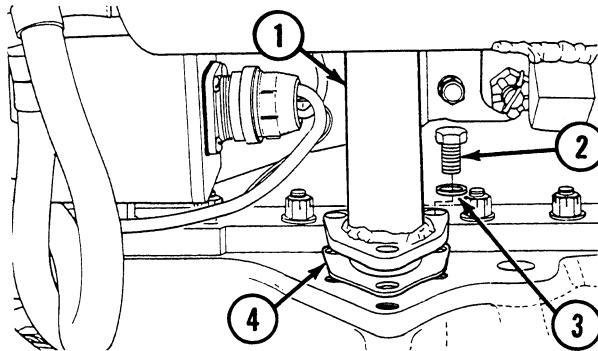

2. Remove two clamps (5) and rubber hose (6) from lower oil fill tube (1).
3. Remove two self-locking nuts (7) and two screws (8) from clamps (9), and remove upper oil fill tube assembly (10).
4. Remove ID plate (11) by removing two drivescrews (12) and two flat washers (13).
5. Remove bracket (14) by removing two screws (15), two washers (16), and two self-locking nuts (17).
6. Remove bracket (18) by removing two screws (19) and two lockwashers (20).

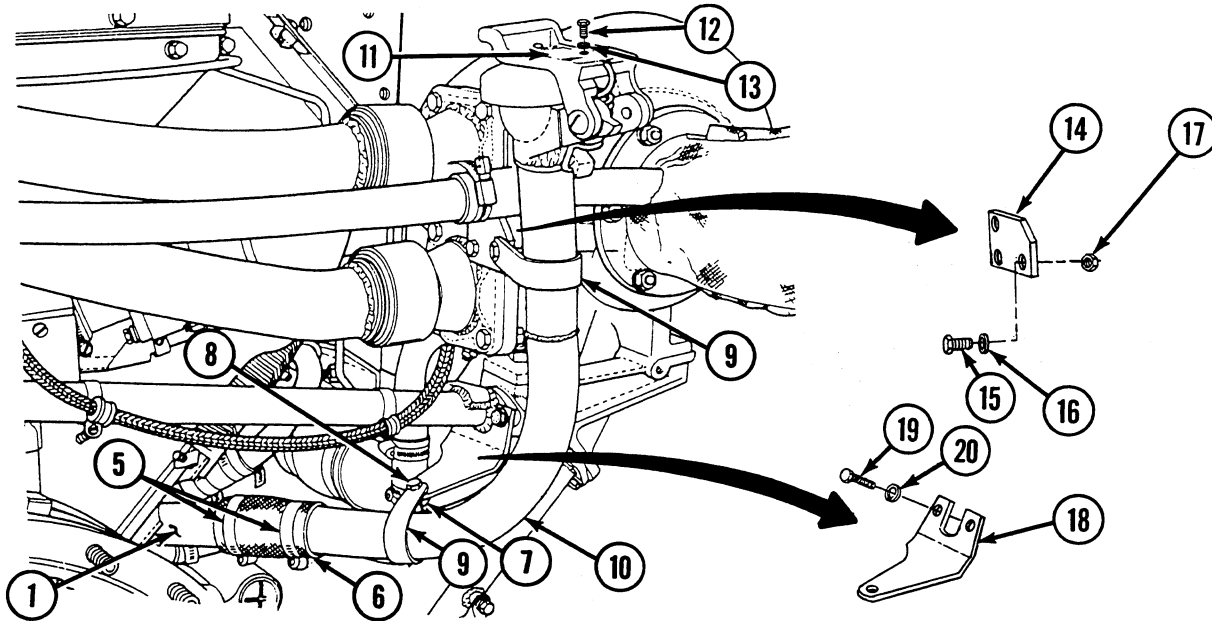

Installation

1. Install bracket (18) with two screws (19) and two lockwashers (20).
2. Install bracket (14) with two screws (15), two flat washers (16), and two self-locking nuts (17).
3. Install ID plate (11) with two flat washers (13) and two drivescrews (12).
4. Install upper oil fill tube assembly (10) with two clamps (9), two self-locking nuts (7), and two screws (8).
5. Connect rubber hose (6) between lower oil fill tube (1) and upper oil fill tube assembly (10). Secure with two clamps (5).
6. Install lower oil fill tube (1) and gasket (4) with three screws (2) and three packings (3).

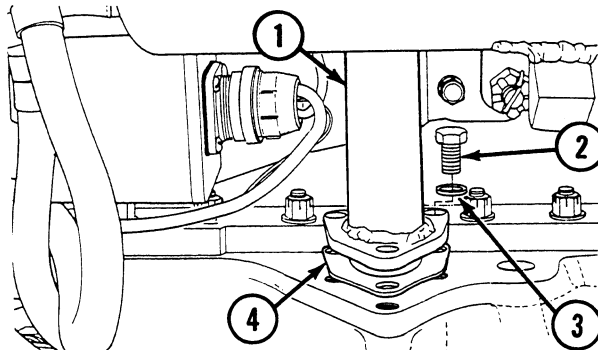

7. Replace engine oil (refer to TM 9-2350-256-10).

NOTE

Follow-on maintenance: Install powerplant (see WP 0098 00).

END OF WORK PACKAGE

UNIT MAINTENANCE
RECOVERY VEHICLE, FULL TRACKED: MEDIUM, M88A1
NSN 2350-00-122-6826, EIC AQA
OIL PAN AND RELATED PARTS REPLACEMENT
REMOVAL, INSTALLATION

INITIAL SETUP:**Tools and Special Tools**

Tool kit, general mechanic's (item 59, WP 0490 00)

Equipment Condition

Powerplant removed (see WP 0098 00)

Materials/Parts

Gasket (item 105, WP 0491 00)

Ring (item 459, WP 0491 00)

NOTE

Place container with minimum capacity of 25 gallons (95 liters) under oil pan before beginning procedure.

Removal

1. Remove plug (1), gasket (2), and ring (3) from oil pan (4).

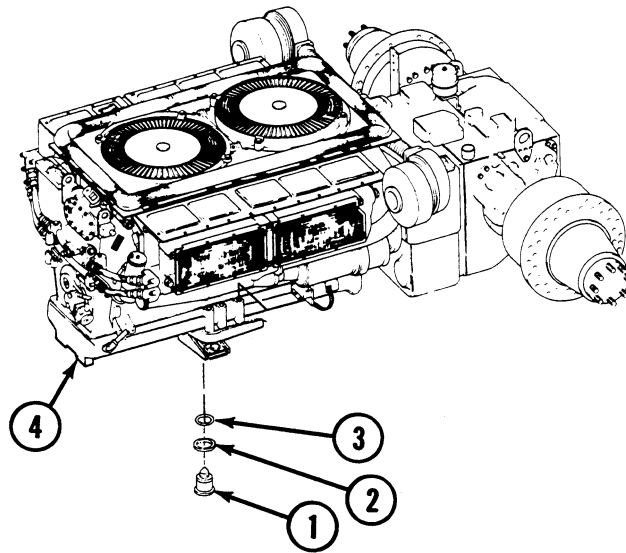
**Installation**

1. Install ring (3), gasket (2), and plug (1) to oil pan (4).

NOTE

Follow-on maintenance: Install powerplant (see WP 0098 00).

END OF WORK PACKAGE

UNIT MAINTENANCE
RECOVERY VEHICLE, FULL TRACKED: MEDIUM, M88A1
NSN 2350-00-122-6826, EIC AQA

CRANKCASE BREATHER TUBE REPLACEMENT
REMOVAL, INSTALLATION

INITIAL SETUP:**Tools and Special Tools**

Tool kit, general mechanic's (item 59, WP 0490 00)

Materials/Parts

Clamps, hose (8) (item 3, WP 0491 00)
Gasket (item 312, WP 0491 00)
Gaskets (2) (item 313, WP 0491 00)
Lockwashers (2) (item 639, WP 0491 00)
Nuts, self-locking (3) (item 491, WP 0491 00)

Materials/Parts (cont.)

Screws (2) (item 815, WP 0491 00)
Washer, flat (item 843, WP 0491 00)

Equipment Condition

Powerplant removed (see WP 0098 00)
Exhaust doors opened (see WP 0346 00)
Transmission access door opened (see WP 0340 00)

Removal

1. Remove tube (1) by removing hose clamps (2) from each end.
2. Remove air duct hose (3) by removing hose clamp (4).
3. Remove air duct hose (5) by removing hose clamp (6).
4. Remove self-locking nut (7), washer (8), and loop clamp (9).
5. Remove tube (10) by removing hose clamps (11) from each end.
6. Remove air duct hose (12) by removing hose clamp (13).
7. Remove two screws (14), two lockwashers (15), breather (16), two gaskets (17), and spacer plate (18).
8. Remove air duct hose (19) by removing hose clamp (20).
9. Remove two self-locking nuts (21), flange adapter (22), and gasket (23).

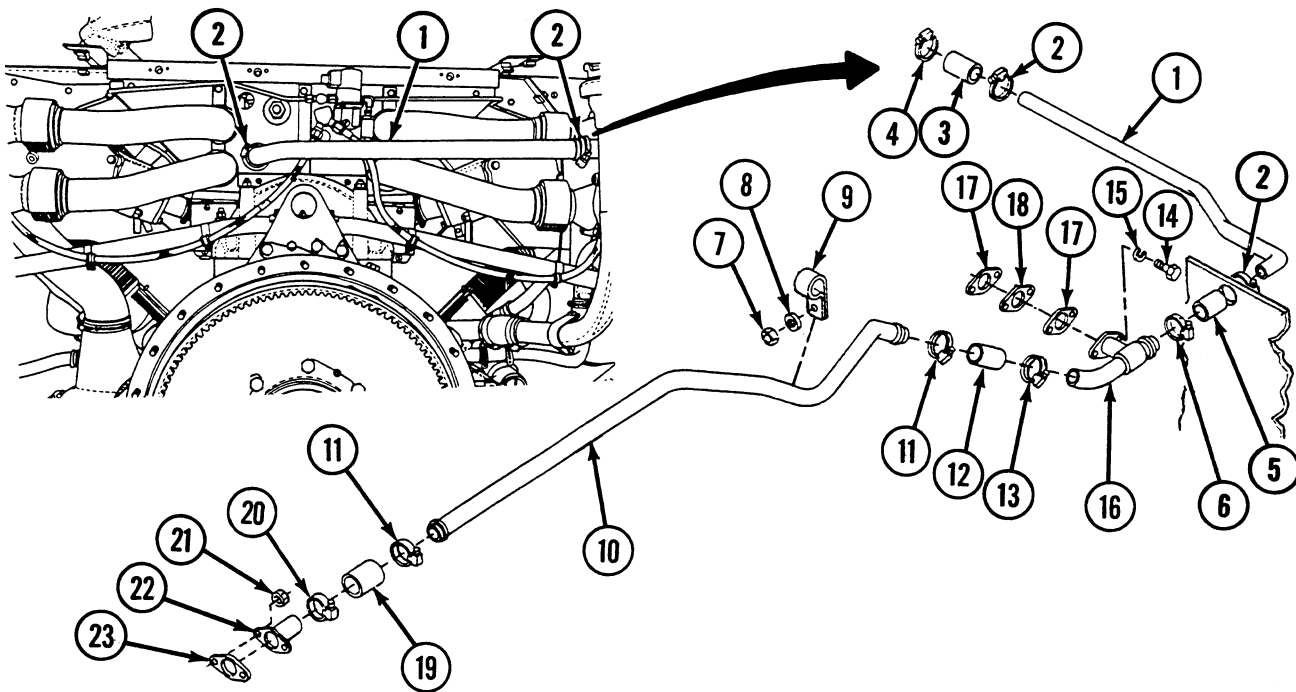

Installation

1. Install breather (16), two lockwashers (15), two gaskets (17), spacer plate (18), and two screws (14). Tighten screws.
2. Install gasket (23), flange adapter (22), and two self-locking nuts (21).
3. Install air duct hose (19) by installing hose clamp (20). Tighten hose clamp.
4. Install air duct hose (12) by installing hose clamp (13). Tighten hose clamp.
5. Install tube (10) by installing hose clamps (11) at each end. Tighten hose clamps.
6. Install loop clamp (9) and washer (8) with self-locking nut (7).
7. Install air duct hose (5) by installing hose clamp (6). Tighten hose clamp.
8. Install air duct hose (3) by installing hose clamp (4). Tighten hose clamp.
9. Install tube (1) by installing hose clamps (2) at each end. Tighten hose clamps.

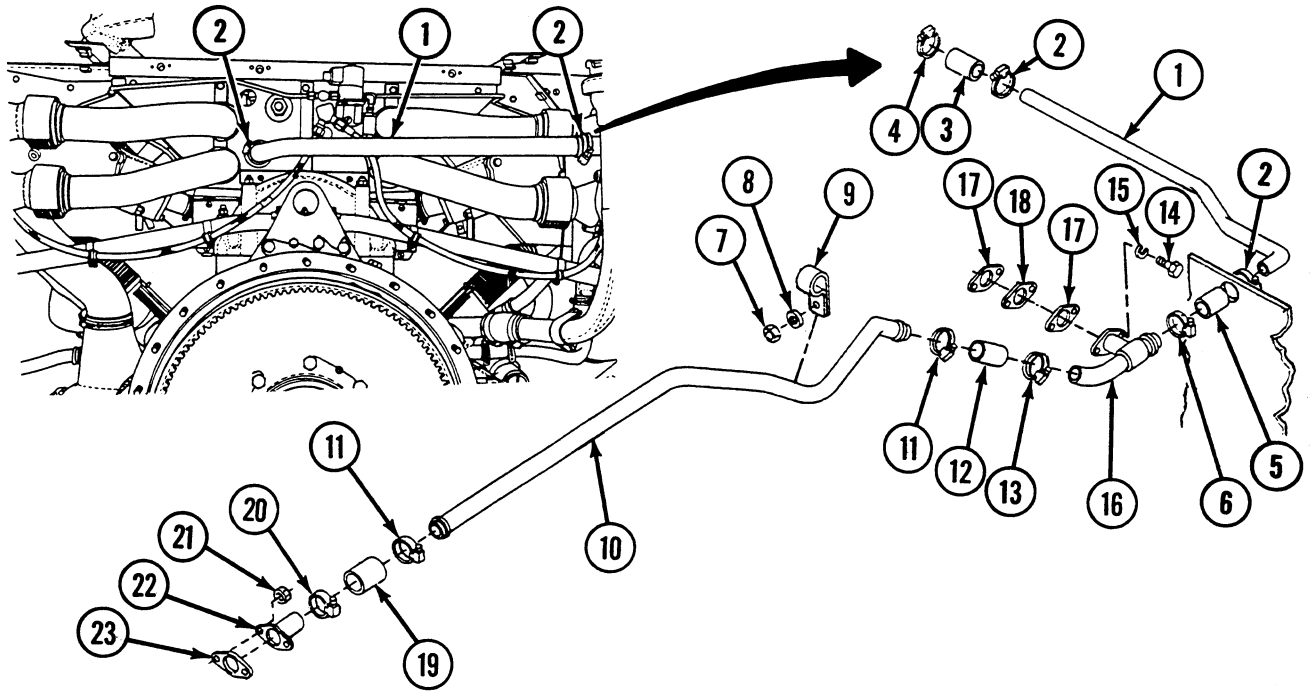

NOTE

Follow-on maintenance: Install powerplant (see WP 0098 00); Close exhaust doors (see WP 0346 00); Close transmission access door (see WP 0340 00).

END OF WORK PACKAGE

UNIT MAINTENANCE
RECOVERY VEHICLE, FULL TRACKED: MEDIUM, M88A1
NSN 2350-00-122-6826, EIC AQA
CYLINDER HEAD OIL PAN DRAIN TUBES AND RELATED PARTS REPLACEMENT
REMOVAL, INSTALLATION

INITIAL SETUP:**Tools and Special Tools**

Tool kit, general mechanic's (item 59, WP 0490 00)

Materials/Parts

Clamps, hose (AR) (item 3, WP 0491 00)
Gaskets (2) (item 850, WP 0491 00)
Lockwashers (2) (item 144, WP 0491 00)
Lockwashers (2) (item 255, WP 0491 00)
Lockwashers (2) (item 639, WP 0491 00)
Lockwire (item 485, WP 0491 00)

Materials/Parts (cont.)

Screws (6) (item 329, WP 0491 00)
Screws (2) (item 428, WP 0491 00)
Screws (4) (item 815, WP 0491 00)
Screws (2) (item 817, WP 0491 00)
Washers (12) (item 165, WP 0491 00)

Equipment Condition

Powerplant removed (see WP 0098 00)

NOTE

Removal and installation procedures are the same for both the left- and right-side cylinder head oil pan drain tubes.

NOTE

Remove clamps (1) as necessary.

Removal

1. Remove cylinder head oil pan drain tube (2) and gasket (3) by removing two screws (4), two lockwashers (5), and two hose clamps (6).
2. Remove two hoses (7) by removing two hose clamps (8).
3. Remove drain tube (9) and hose (10) by removing two hose clamps (11).
4. Remove tube (12) by removing two screws (13) and two lockwashers (14).
5. Remove drain tube assembly (15) and hose (16) by removing two hose clamps (17), lockwire (18), screw (19), and two flat washers (20).
6. Remove tube assembly (21) and hose (16) by removing two hose clamps (17), lockwire (18), screw (19), and two flat washers (20).
7. Remove tube assembly (22) and hose (16) by removing two hose clamps (17), lockwire (18), screw (19), and two flat washers (20).
8. Remove tube assembly (23) and hose (16) by removing two hose clamps (17), lockwire (18), screw (19), and two flat washers (20).
9. Remove tube assembly (24) and hose (16) by removing two hose clamps (17), lockwire (18), screw (19), and two flat washers (20).
10. Remove tube assembly (25) and hose (26) by removing two hose clamps (27), lockwire (18), screw (19), and two flat washers (20).
11. Remove tube (28) and hose (29) by removing two hose clamps (30).
12. Remove elbow (31) and gasket (32) by removing two screws (33) and two lockwashers (34).

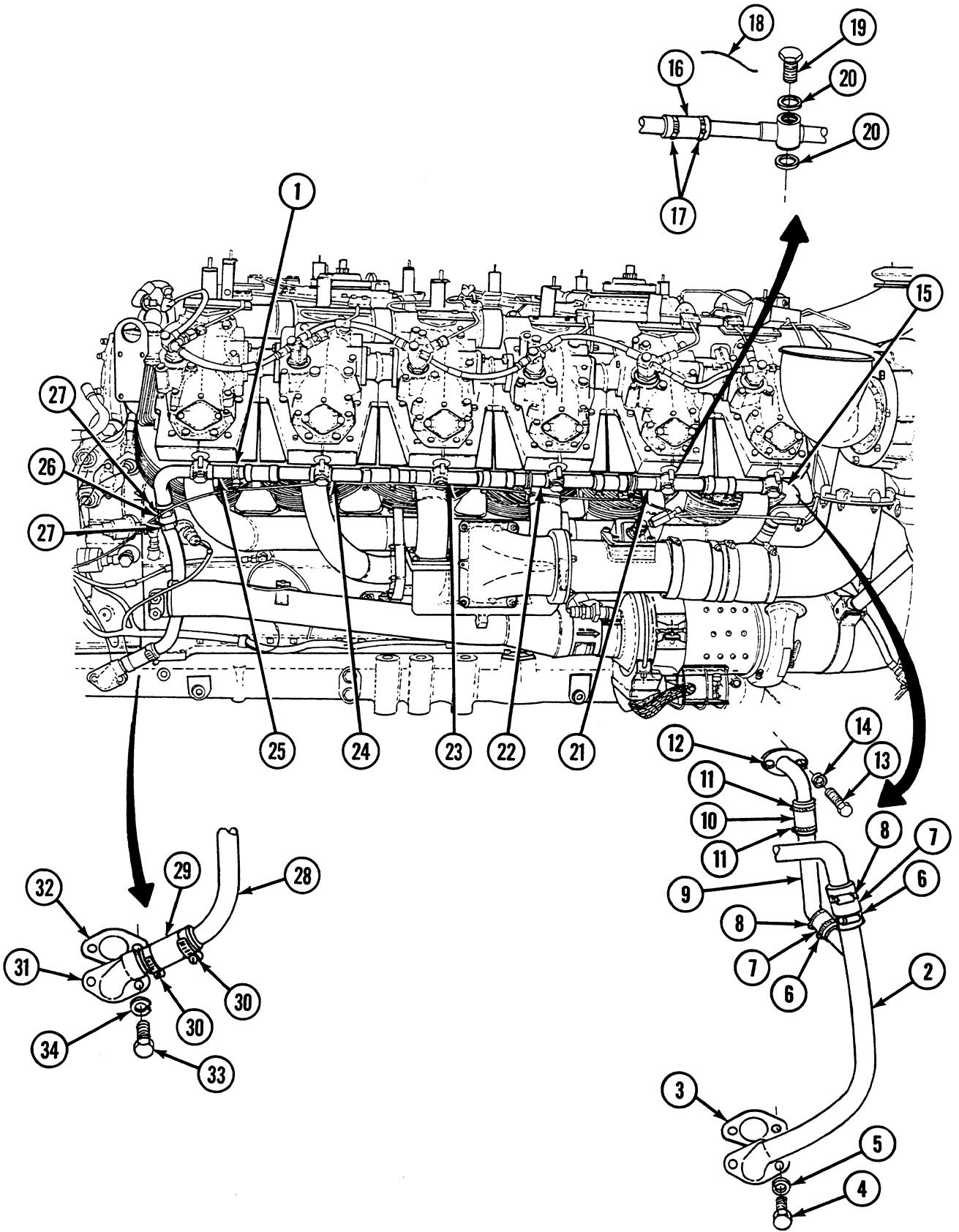

Installation

1. Install elbow (31) and gasket (32) with two screws (33) and two lockwashers (34).
2. Install tube (28) and hose (29) with two hose clamps (30).
3. Install tube assembly (25) and hose (26) with two hose clamps (27), lockwire (18), screw (19), and two flat washers (20).
4. Install tube assembly (24) and hose (16) with two hose clamps (17), lockwire (18), screw (19), and two flat washers (20).
5. Install tube assembly (23) and hose (16) with two hose clamps (17), lockwire (18), screw (19), and two flat washers (20).
6. Install tube assembly (22) and hose (16) with two hose clamps (17), lockwire (18), screw (19), and two flat washers (20).
7. Install tube assembly (21) and hose (16) with two hose clamps (17), lockwire (18), screw (19), and two flat washers (20).
8. Install drain tube assembly (15) and hose (16) with two hose clamps (17), lockwire (18), screw (19), and two flat washers (20).
9. Install tube (12) with two screws (13) and two lockwashers (14).
10. Install drain tube (9) and hose (10) with two hose clamps (11).
11. Install two hoses (7) with two hose clamps (8).
12. Install cylinder head oil pan drain tube (2) and gasket (3) with two screws (4), two lockwashers (5), and two hose clamps (6).

NOTE

Install clamps (1) if removed.

NOTE

Follow-on maintenance: Install powerplant (see WP 0098 00).

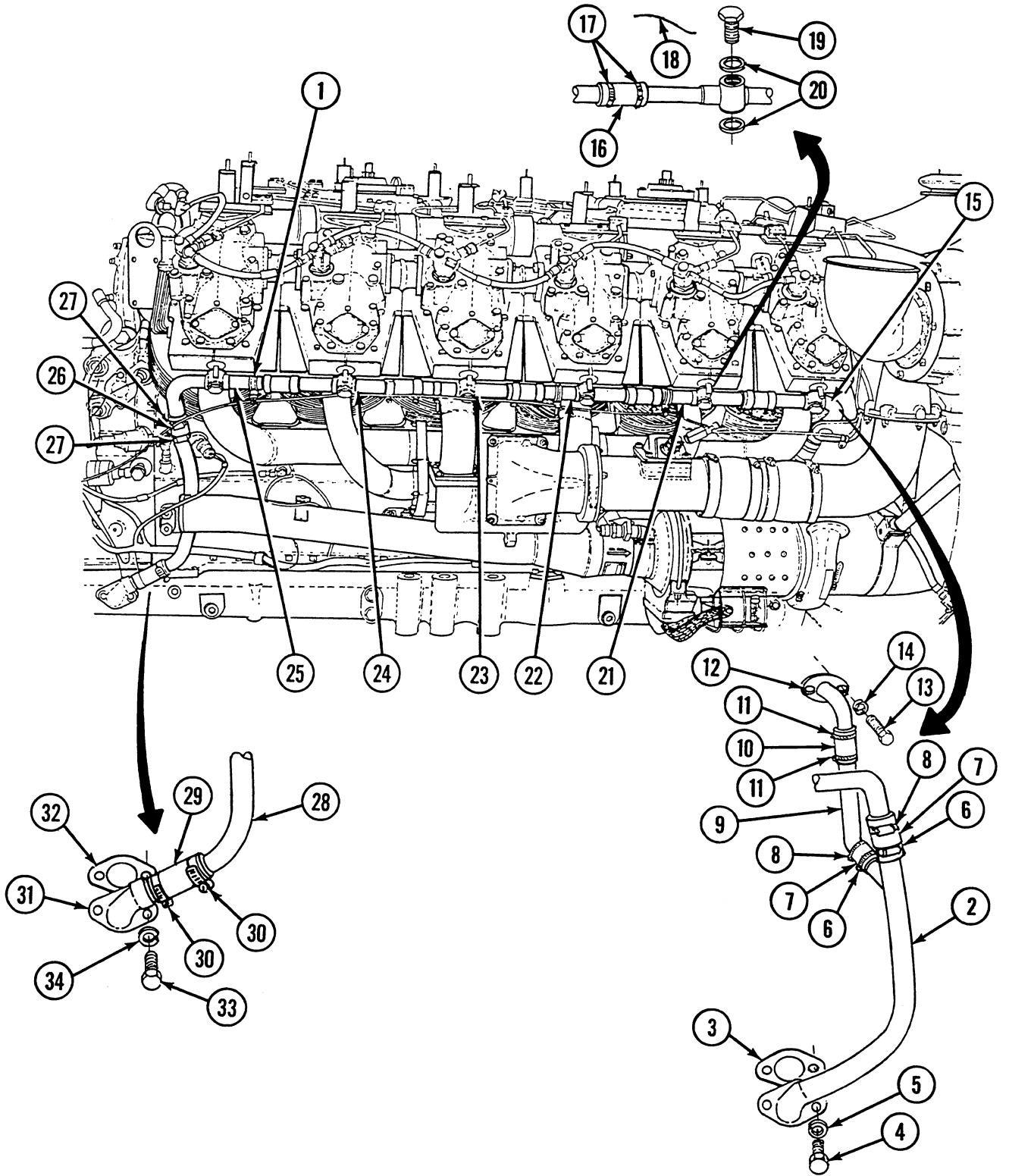

END OF WORK PACKAGE

UNIT MAINTENANCE
RECOVERY VEHICLE, FULL TRACKED: MEDIUM, M88A1
NSN 2350-00-122-6826, EIC AQA
OIL COOLER PRESSURE-ACTUATED BYPASS VALVE REPLACEMENT
REMOVAL, INSTALLATION

INITIAL SETUP:**Tools and Special Tools**

Tool kit, general mechanic's (item 59, WP 0490 00)

Equipment Condition

Grille doors removed (see WP 0342 00)

Materials/Parts

Gasket (item 707, WP 0491 00)

Spring (item 110, WP 0491 00)

Removal

1. Remove oil cooler bypass valve plug (1), gasket (2), spring (3), and plunger (4).

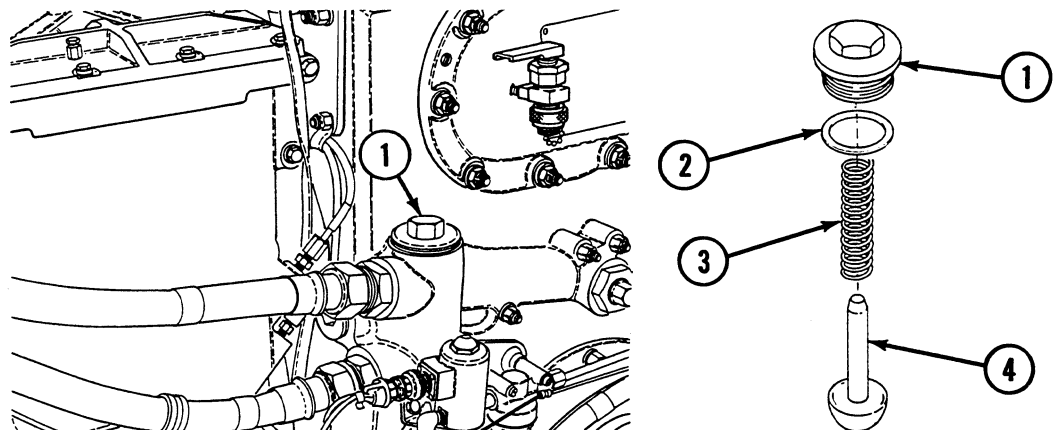
**Installation**

1. Install plunger (4), spring (3), gasket (2), and oil cooler bypass valve plug (1).

NOTE

Follow-on maintenance: Install grille doors (see WP 0342 00).

END OF WORK PACKAGE

UNIT MAINTENANCE
RECOVERY VEHICLE, FULL TRACKED: MEDIUM, M88A1
NSN 2350-00-122-6826, EIC AQA

**GENERATOR AIR INTAKE TUBE REPLACEMENT
REMOVAL, INSTALLATION**

INITIAL SETUP:

Tools and Special Tools

Tool kit, general mechanic's (item 59, WP 0490 00)

Materials/Parts

Clamps (3) (item 715, WP 0491 00)
Lockwashers (2) (item 638, WP 0491 00)
Lockwashers (2) (item 639, WP 0491 00)

Materials/Parts (cont.)

Screws (2) (item 782, WP 0491 00)
Screws (2) (item 794, WP 0491 00)

Equipment Condition

Grille doors removed (see WP 0342 00)

Removal

1. Remove two screws (1), two lockwashers (2), and clamp (3) from air intake tube (4).
2. Remove air intake tube (4) from hose (5) by removing clamp (6).
3. Remove hose (7) from hose (8) by removing two clamps (9).

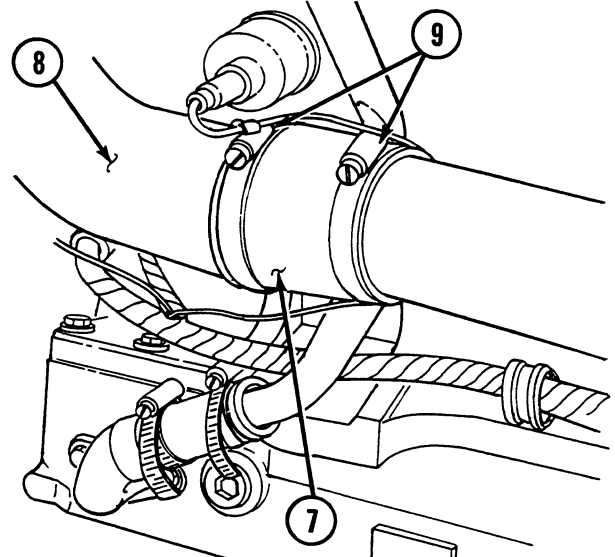
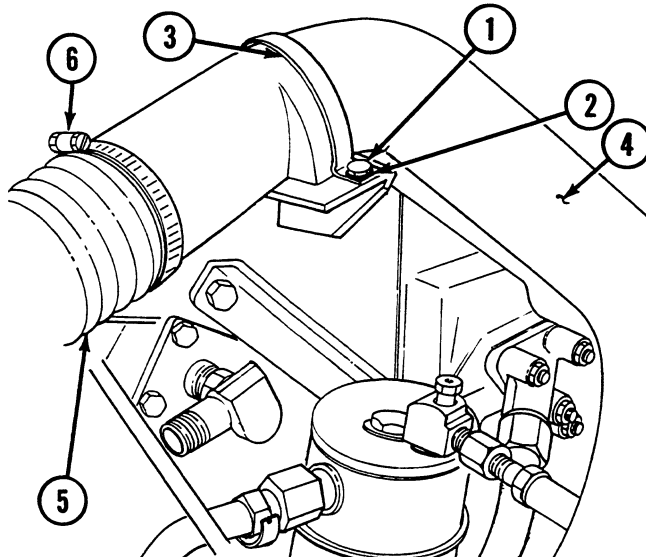

4. Remove mounting bracket (10) by removing two screws (11) and two lockwashers (12).

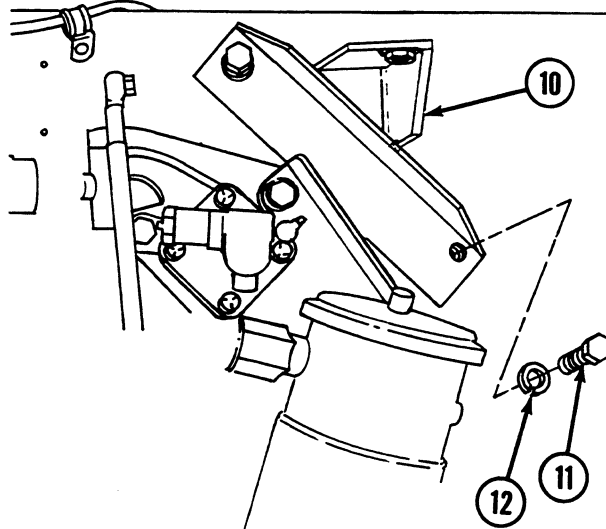

Installation

1. Install mounting bracket (10) with two screws (11) and two lockwashers (12).
2. Install hose (7) to hose (8) with two clamps (9).
3. Install air intake tube (4) to hose (5) with clamp (6).
4. Install clamp (3) to air intake tube (4) with two screws (1) and two lockwashers (2).

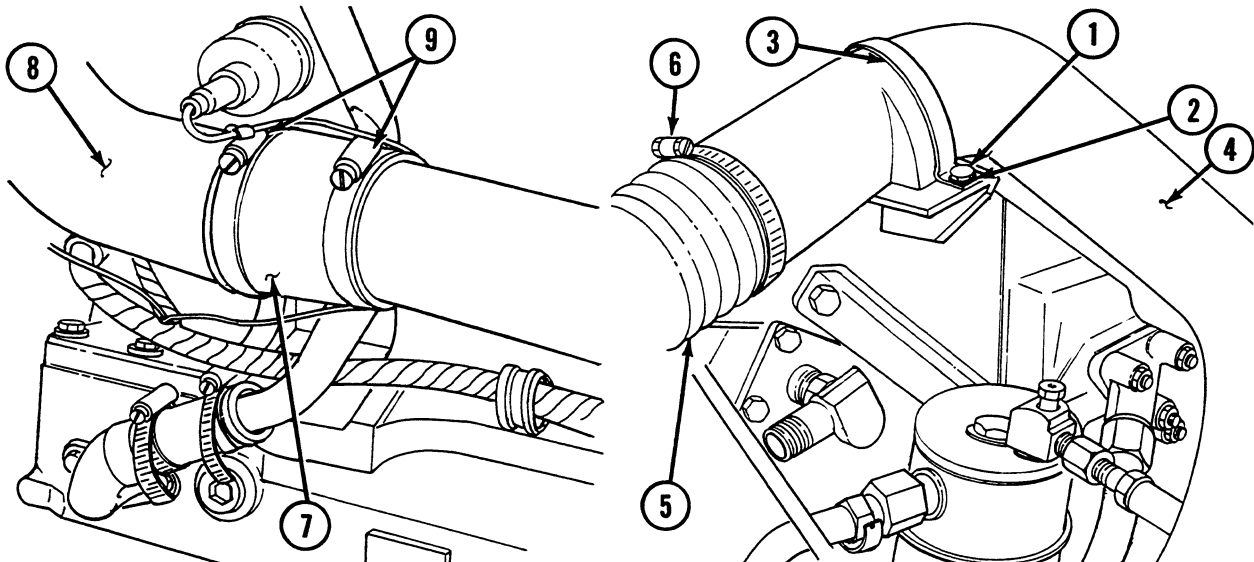

NOTE

Follow-on maintenance: Install grille doors (see WP 0342 00).

END OF WORK PACKAGE

UNIT MAINTENANCE
RECOVERY VEHICLE, FULL TRACKED: MEDIUM, M88A1
NSN 2350-00-122-6826, EIC AQA
ENGINE IDLE SPEED ADJUSTMENT

INITIAL SETUP:**Tools and Special Tools**

Tool kit, general mechanic's (item 59, WP 0490 00)

Equipment Condition

Grille doors removed (see WP 0342 00)

References

TM 9-2350-256-10

Adjustment

1. With engine running and operating temperature normal (refer to TM 9-2350-256-10), loosen locknut (1) on idle speed adjusting screw (2).

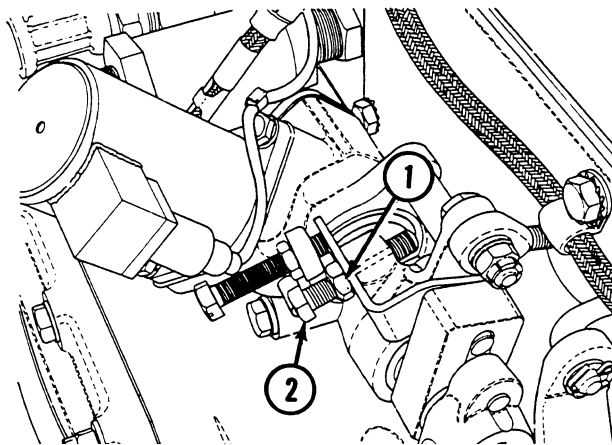

2. Turn idle speed adjusting screw (2) clockwise to increase speed or counterclockwise to decrease speed.
3. Tighten locknut (1) after 675-725 revolutions per minute (rpm) is obtained.

NOTE

Follow-on maintenance: Install grille doors (see WP 0342 00).

END OF WORK PACKAGE

UNIT MAINTENANCE
RECOVERY VEHICLE, FULL TRACKED: MEDIUM, M88A1
NSN 2350-00-122-6826, EIC AQA
ENGINE SOLENOID SPEED ADJUSTMENT

INITIAL SETUP:**Tools and Special Tools**

Tool kit, general mechanic's (item 59, WP 0490 00)

References

TM 9-2350-256-10

Personnel Required

Mechanics (2)

Equipment Condition

Grille doors removed (see WP 0342 00)

Adjustment**CAUTION**

Do not allow engine to exceed 1800 rpm with power takeoff engaged.

1. With engine running and operating temperature normal (refer to TM 9-2350-256-10), loosen locknut (1) on solenoid speed control adjusting screw (2). Activate power takeoff and have assistant increase engine speed to 1800 rpm.
2. If 1800 rpm cannot be obtained when solenoid speed control adjusting screw (2) engages stop (3), turn adjusting screw counterclockwise to increase rpm. If adjusting screw has not engaged stop when 1800 rpm is obtained, turn adjusting screw clockwise until it engages stop.

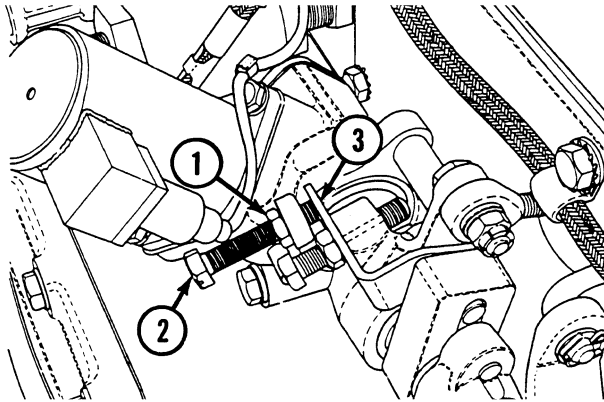

3. Allow engine to return to idle speed, increase engine speed to 1800 rpm, and recheck adjustment. If adjustment is not correct, repeat step 2.
4. Tighten locknut (1) after correct rpm (1800 rpm at no load) is obtained.

NOTE

Follow-on maintenance: Install grille doors (see WP 0342 00).

END OF WORK PACKAGE

CHAPTER 5
UNIT MAINTENANCE
MAINTENANCE INSTRUCTIONS
FOR
ENGINE FUEL, AIR INTAKE, AND EXHAUST SYSTEM
RECOVERY VEHICLE, FULL TRACKED: MEDIUM, M88A1
(NSN: 2350-00-122-6826)

CHAPTER 5
UNIT MAINTENANCE
MAINTENANCE INSTRUCTIONS

WORK PACKAGE INDEX

<u>Title</u>	<u>WP Sequence No.</u>
Fuel Injector Tubes, Brackets, and Related Parts Replacement Removal, Installation	0114 00
Engine Right and Left Upper Covers Replacement Removal, Installation	0115 00
Electric Fuel Pump Maintenance Removal, Disassembly, Assembly, Installation, Testing.....	0116 00
Fuel Transfer Pump Hoses and Related Parts Replacement Removal, Installation.....	0117 00
Fuel Pump (Gear Type), Lines, and Related Parts Maintenance Removal, Installation, Testing.....	0118 00
Fuel Injector Fuel Return Hose Replacement Removal, Installation	0119 00
Fuel Filler Tube and Filler Strainer Maintenance Removal, Disassembly, Cleaning, Assembly, Installation	0120 00
Fuel Level Transmitter Replacement Removal, Installation.....	0121 00
Purge Pump/Handle/Lever Maintenance Removal, Disassembly, Assembly, Installation	0122 00
Fuel Valve Lines and Fittings Maintenance Removal, Repair, Installation.....	0123 00
Engine Fuel Manual Shutoff Control Maintenance Removal, Installation, Adjustment.....	0124 00
Fuel Control Valves and ID Plates Replacement Removal, Installation.....	0125 00
Fuel Check Valve Maintenance Removal, Installation, Testing.....	0126 00
Primary Fuel Filter Maintenance Servicing, Removal, Disassembly, Cleaning, Assembly, Installa- tion.....	0127 00
Fuel/Water Separator Filter Elements Replacement Removal, Installation	0128 00
Fuel/Water Separator Filter Unit Replacement Removal, Installation.....	0129 00
Fuel/Water Separator Automatic Drain System and Solenoid Valve Replacement Removal, Installa- tion.....	0130 00
Manifold Heater Fuel Supply Solenoid Valve and Fuel Filter Replacement Removal, Installation	0131 00
Manifold Heater Ignition Unit Replacement Removal, Installation	0132 00
Manifold Heater Fuel Return Solenoid Valve Replacement Removal, Installation	0133 00
Manifold Heater Nozzle Assembly Maintenance Removal, Disassembly, Assembly, Installation.....	0134 00
Manifold Heater Operation Check.....	0135 00
Manifold Heater Fuel Lines and Fittings Replacement Removal, Installation.....	0136 00
Air Cleaner Maintenance Removal, Disassembly, Service, Assembly, Installation	0137 00
Air Cleaner Restriction Gage Assembly Replacement Removal, Installation	0138 00
Air Intake Hoses Replacement Removal, Installation	0139 00
Engine Air Inlet Seal Replacement Removal, Installation.....	0140 00
Exhaust Pipes Replacement Removal, Installation.....	0141 00
Exhaust Manifold Clamps Replacement Removal, Installation.....	0142 00

UNIT MAINTENANCE
RECOVERY VEHICLE, FULL TRACKED: MEDIUM, M88A1
NSN 2350-00-122-6826, EIC AQA
FUEL INJECTOR TUBES, BRACKETS, AND RELATED PARTS REPLACEMENT
REMOVAL, INSTALLATION

INITIAL SETUP:**Tools and Special Tools**

Tool kit, general mechanic's (item 59, WP 0490 00)

Materials/Parts

Nuts, self-locking (71) (item 495, WP 0491 00)
Screws (2) (item 77, WP 0491 00)
Screws (58) (item 386, WP 0491 00)
Screw (item 796, WP 0491 00)

Equipment Condition

Engine right and left upper covers removed (see WP 0115 00)
Engine cooling fan shroud and related parts removed (see WP 0146 00)

WARNING

Do not smoke or use open flame when working on fuel system: explosion may occur, causing severe injury or death.

Removal

1. Remove 12 retaining straps (1) and 24 fairlead halves (2) by removing 24 self-locking nuts (3) and 24 screws (4).
2. Remove 14 retaining straps (5) and 14 fairlead halves (6) by removing self-locking nut (7) and screw (8) from each.
3. Remove spacer plate (9) and two retaining straps (10) by removing self-locking nut (11) and screw (12).
4. Remove two retaining straps (13), four fairlead halves (14), and spacer plate (15) by removing two nuts (16) and two screws (17).
5. Remove retaining strap (18) and two fairlead halves (19) by removing two screws (20).
6. Remove bracket (21) by removing two self-locking nuts (22).
7. Remove retaining strap (23) and two fairlead halves (24) by removing two self-locking nuts (25) and two screws (26).
8. Remove bracket (27) by removing two self-locking nuts (28).
9. Remove 4 retaining straps (29) and 8 fairlead halves (30) by removing 16 self-locking nuts (31) and 16 screws (32).
10. Remove four brackets (33) by removing eight self-locking nuts (34).

NOTE

To aid in installation, tag all tube assemblies before removal.

11. Remove 12 tube assemblies (35–46) by loosening coupling nuts at each end of tube assembly.

Installation**NOTE**

When tightening coupling nuts, first tighten coupling nut snugly to seat sleeve and then tighten an additional 1/16 (minimum) to 1/3 (maximum) of a turn to complete operation.

1. Install 12 tube assemblies (35–46) by tightening coupling nuts at each end of tube assembly. Remove tags.
2. Install four brackets (33) with eight self-locking nuts (34).
3. Install 4 retaining straps (29) and 8 fairlead halves (30) with 16 self-locking nuts (31) and 16 screws (32).
4. Install bracket (27) with two self-locking nuts (28).
5. Install retaining strap (23) and two fairlead halves (24) with two self-locking nuts (25) and two screws (26).
6. Install bracket (21) with two self-locking nuts (22).
7. Install retaining strap (18) and two fairlead halves (19) with two screws (20).
8. Install two retaining straps (13), four fairlead halves (14), and spacer plate (15) with two screws (17) and two nuts (16).
9. Install spacer plate (9) and two retaining straps (10) with self-locking nut (11) and screw (12).
10. Install 14 retaining straps (5) and 14 fairlead halves (6) each with screw (8) and self-locking nut (7).
11. Install 12 retaining straps (1) and 24 fairlead halves (2) with 24 self-locking nuts (3) and 24 screws (4).

NOTE

Follow-on maintenance: Install engine cooling fan shroud and related parts (see WP 0146 00); Install engine right and left upper covers (see WP 0115 00).

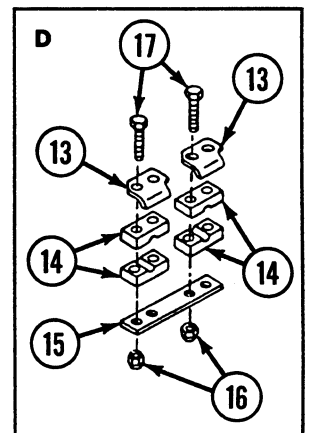
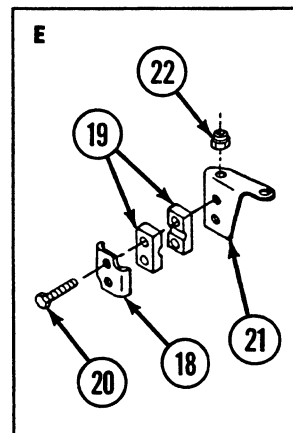
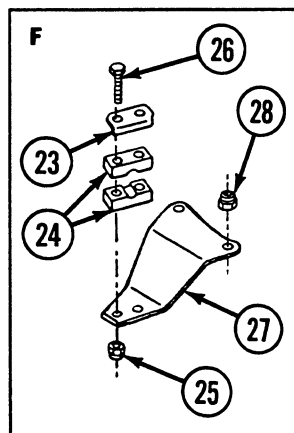
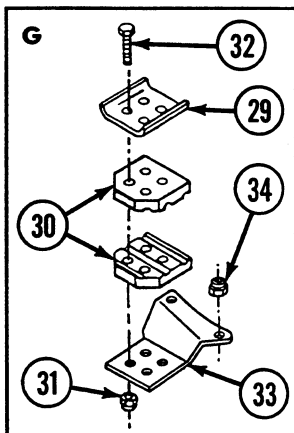
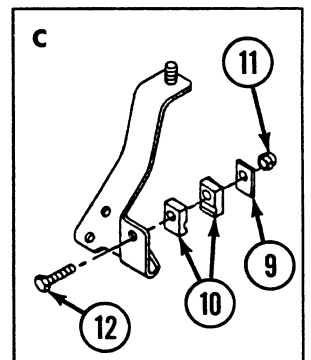
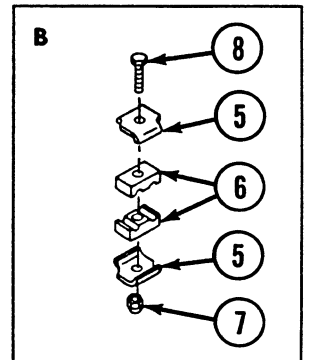
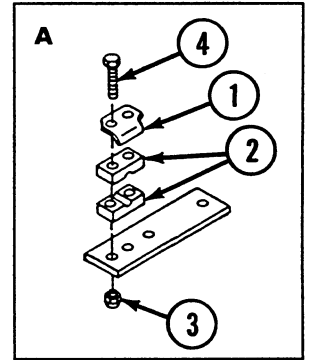
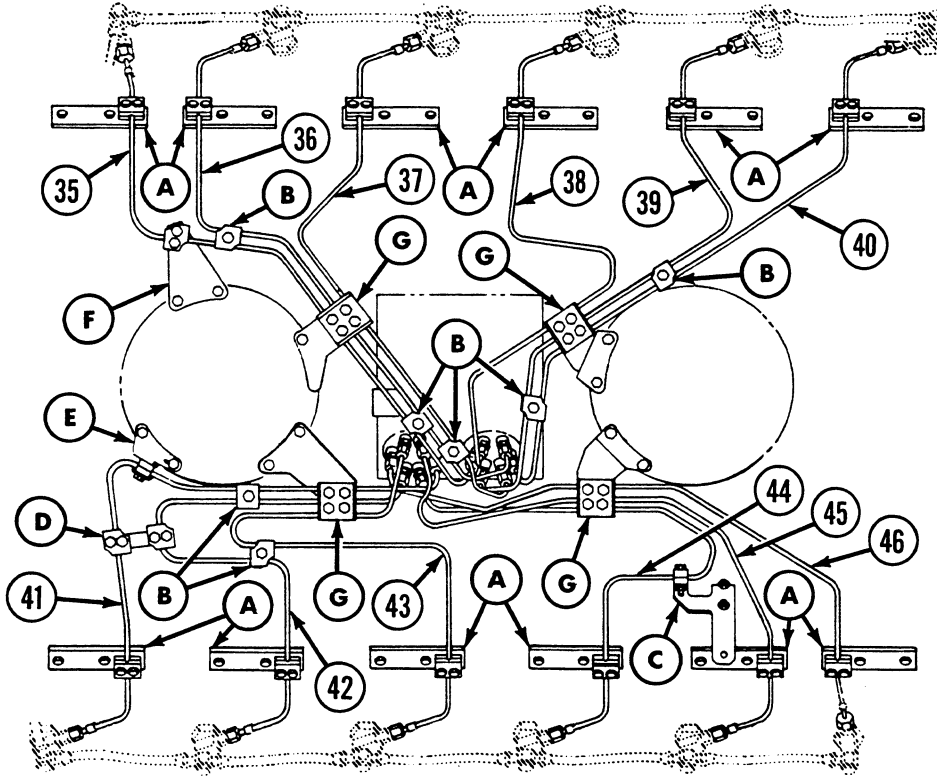

END OF WORK PACKAGE

UNIT MAINTENANCE
RECOVERY VEHICLE, FULL TRACKED: MEDIUM, M88A1
NSN 2350-00-122-6826, EIC AQA
ENGINE RIGHT AND LEFT UPPER COVERS REPLACEMENT
REMOVAL, INSTALLATION

INITIAL SETUP:**Tools and Special Tools**

Tool kit, general mechanic's (item 59, WP 0490 00)

Materials/Parts

Gasket (item 64, WP 0491 00)

Lockwashers (2) (item 639, WP 0491 00)

Packings, preformed (2) (item 438, WP 0491 00)

Materials/Parts (cont.)

Screws (44) (item 256, WP 0491 00)

Screws (2) (item 791, WP 0491 00)

Equipment Condition

Engine deck removed for access to engine covers (see WP 0336 00)

WARNING

Do not smoke or use open flame when working on fuel system: explosion may occur, causing severe injury or death.

NOTE

Powerplant shown removed for clarity only.

Removal

1. Remove oil level gage rod (1).
2. Remove right front upper cover (2) and strap (3) by removing 12 screws (4).

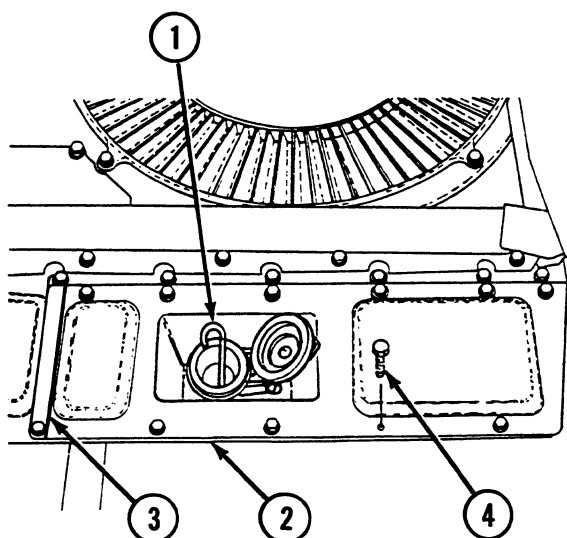

3. Remove oil level indicator tube cap assembly (5) from right front upper cover (2) by removing two screws (6) and two lockwashers (7). Remove gasket (8) and two preformed packings (9) from oil level indicator tube cap assembly.

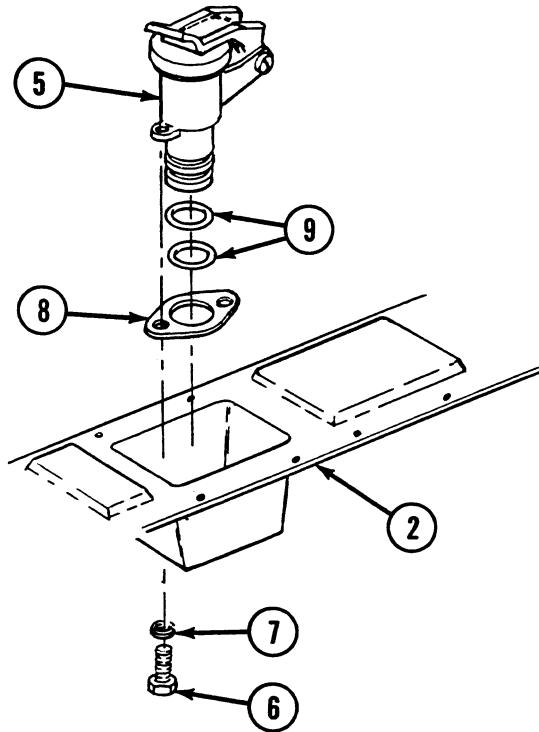

4. Remove right rear upper cover (10) by removing 10 screws (11).

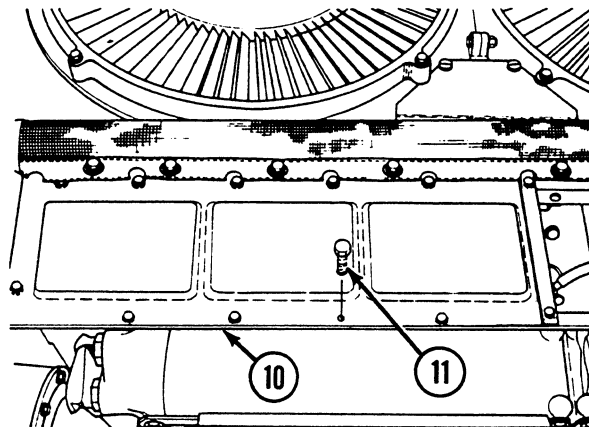

5. Remove left front upper cover (12) by removing 10 screws (13).
6. Remove left rear upper cover (14) by removing 12 screws (15).

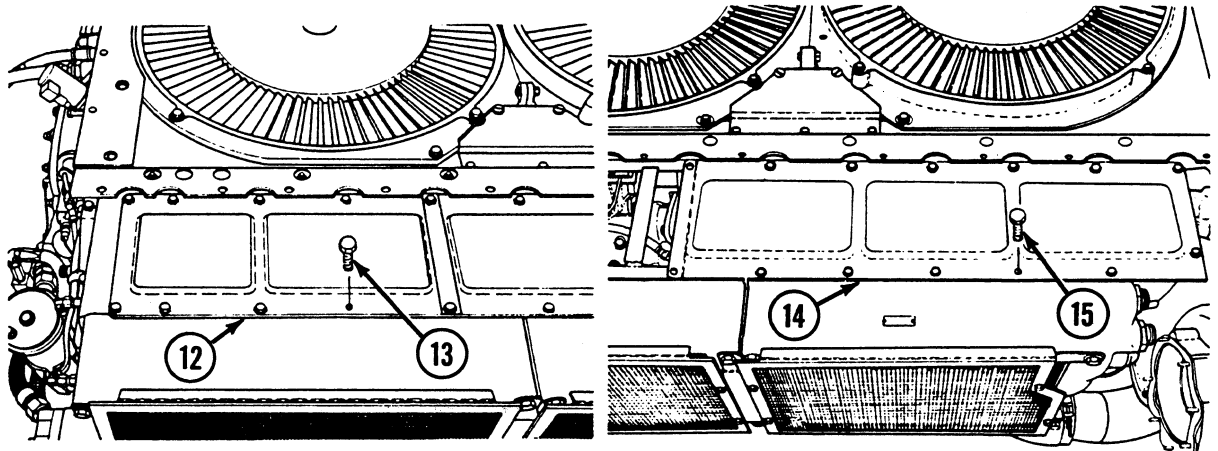

Installation

1. Install left rear upper cover (14) with 12 screws (15).
2. Install left front upper cover (12) with 10 screws (13).
3. Install right rear upper cover (10) with 10 screws (11).
4. Assemble oil level indicator tube cap assembly (5) to right front upper cover (2) with gasket (8), two preformed packings (9), two screws (6), and two lockwashers (7).
5. Install right front upper cover (2) and strap (3) with 12 screws (4).
6. Install oil level gage rod (1).

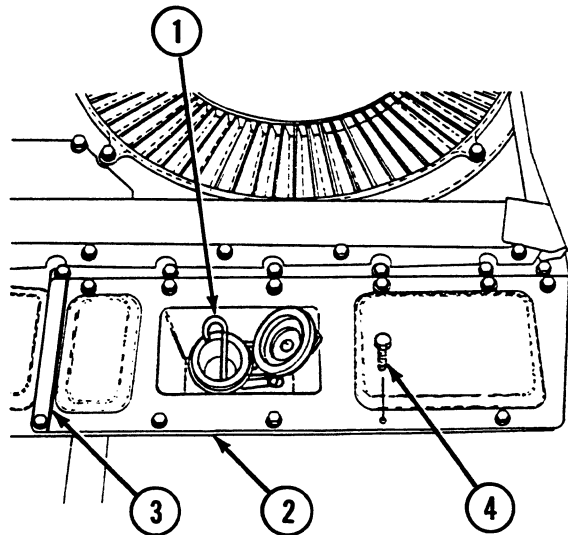

NOTE

Follow-on maintenance: Install engine deck (see WP 0336 00).

END OF WORK PACKAGE

UNIT MAINTENANCE
RECOVERY VEHICLE, FULL TRACKED: MEDIUM, M88A1
NSN 2350-00-122-6826, EIC AQA
ELECTRIC FUEL PUMP MAINTENANCE
REMOVAL, DISASSEMBLY, ASSEMBLY, INSTALLATION, TESTING

INITIAL SETUP:**Tools and Special Tools**

Tool kit, general mechanic's (item 59, WP 0490 00)
 Suitable container

Materials/Parts

Tape, sealant (item 34, WP 0489 00)
 Gasket (item 58, WP 0491 00)
 Gasket (item 107, WP 0491 00)
 Gasket (item 287, WP 0491 00)
 Lockwashers (3) (item 120, WP 0491 00)
 Lockwasher (item 617, WP 0491 00)
 Lockwashers (2) (item 618, WP 0491 00)
 Lockwashers (12) (item 639, WP 0491 00)
 Nuts (3) (item 127, WP 0491 00)

Materials/Parts (cont.)

Packing (item 133, WP 0491 00)
 Screws (12) (item 383, WP 0491 00)
 Screw (item 569, WP 0491 00)
 Screw (item 571, WP 0491 00)
 Seal (item 430, WP 0491 00)

References

WP 0123 00
 TM 9-2350-256-10

Equipment Condition

Intermediate rear left-center floor plate removed (see WP 0302 00)

WARNING

Do not smoke or use open flame when working on fuel system: explosion may occur, causing severe injury or death.

CAUTION

Do not allow gasket particles, dirt, rags, or other foreign material to enter fuel tank while electric fuel pump is removed. If electric fuel pump is not immediately replaced, cover opening with sealant tape or other suitable material.

Removal

1. Disconnect fuel lines with reducers (1) and tee (2) from electric fuel pump (3).
2. Disconnect cable connector (4).
3. Remove 12 screws (5), 12 lockwashers (6), and ground cable (7).
4. Remove electric fuel pump (3) and gasket (8).

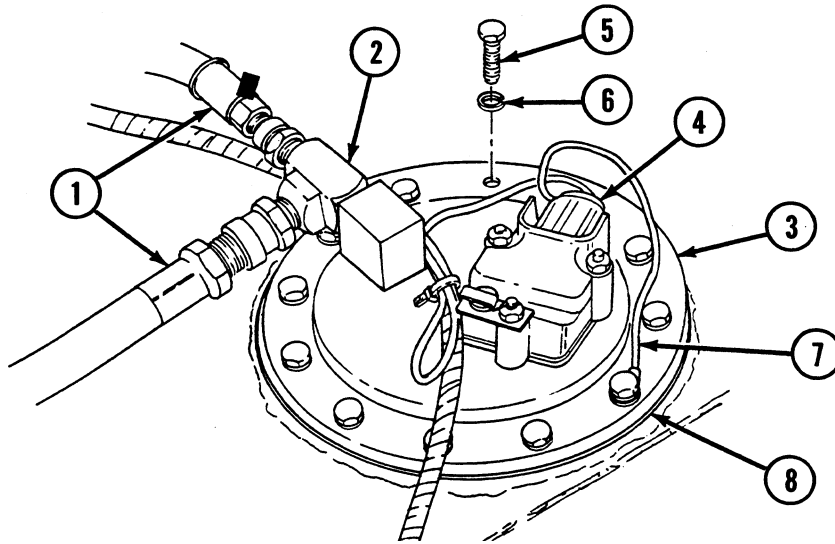

5. Remove seal (9).
6. Remove three nuts (10) and three lockwashers (11).
7. Remove retainer (12).
8. Remove terminal assembly (13) and gasket (14).

9. Remove discharge fitting (15) and packing (16).

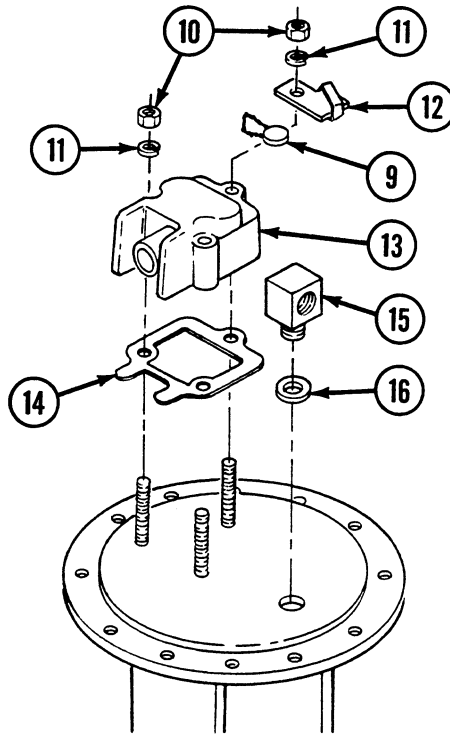

Disassembly

1. Remove cartridge fuse (17).
2. Disconnect electric cable (18).
3. Remove screw (19), lockwasher (20), pin assembly (21), and fuseholder (22).
4. Remove screw (23) and lockwasher (24).
5. Remove shoulder pin (25) and lockwasher (26).
6. Remove fuel plate retainer (27), shell receptacle (28), and gasket (29).

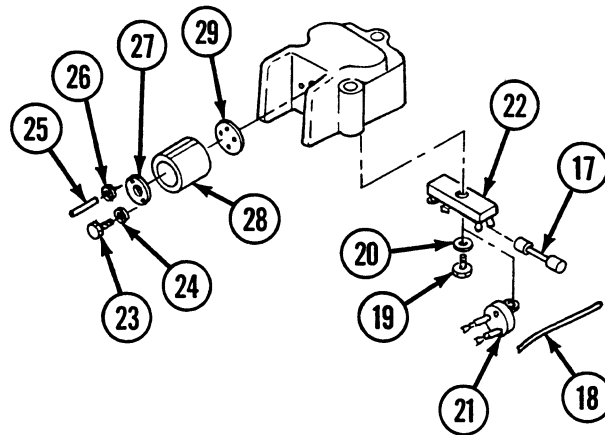

Assembly

1. Install gasket (29), shell receptacle (28), and fuel plate retainer (27).
2. Install lockwasher (26) and shoulder pin (25).
3. Install lockwasher (24) and screw (23).
4. Install fuseholder (22), pin assembly (21), lockwasher (20), and screw (19).
5. Connect electric cable (18).
6. Install cartridge fuse (17).

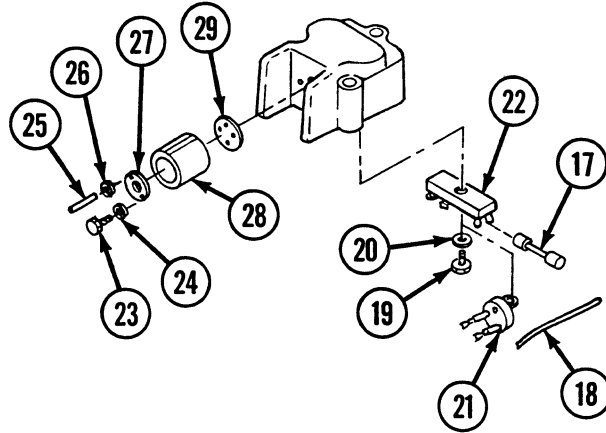
**Installation**

1. Install packing (16) and discharge fitting (15).
2. Install gasket (14) and terminal assembly (13).
3. Install retainer (12).
4. Install three lockwashers (11) and three nuts (10).

5. Install seal (9).

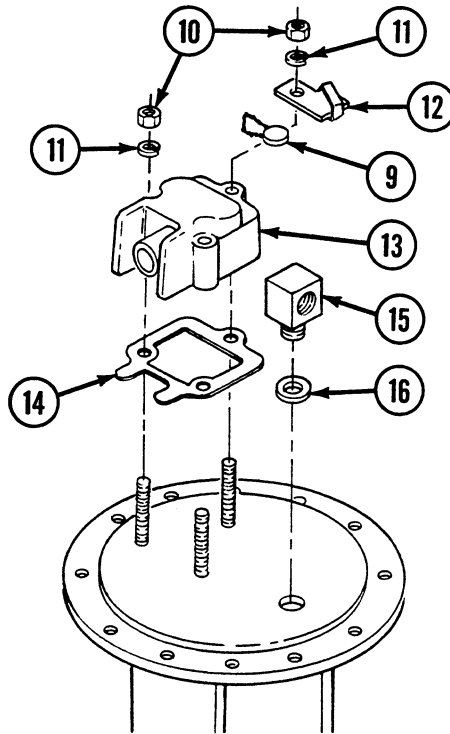

6. Install gasket (8), electric fuel pump (3), and ground cable (7) with 12 screws (5) and 12 lockwashers (6).
7. Connect cable connector (4).
8. Connect fuel lines with reducers (1) and tee (2) to electric fuel pump (3) using sealant tape.

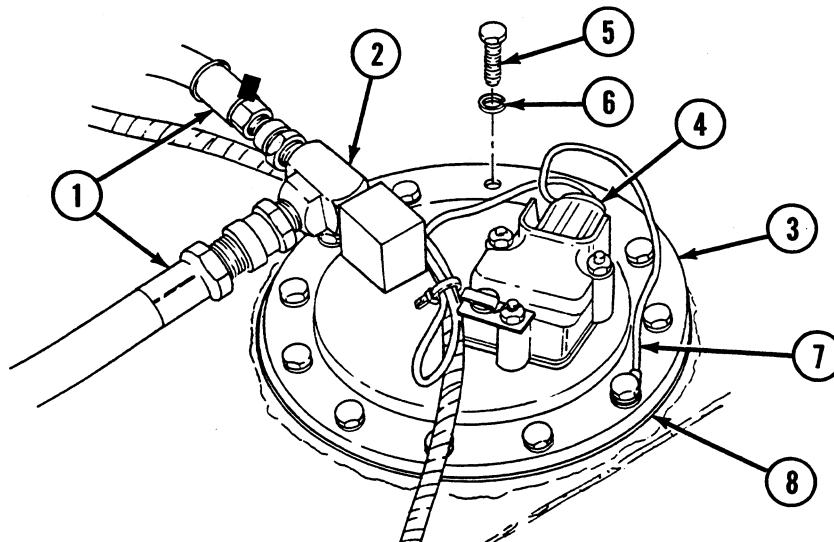

Testing

1. Disconnect fuel tank supply hose quick disconnect (see WP 0123 00). Open coupling valve to collect fuel in suitable, 5-gallon (19-liter) container.
2. Turn MASTER switch and in-tank fuel pump switch to ON position (refer to TM 9-2350-256-10).
3. Time fuel flow into measured container.
4. Flow rate of 3 gallons per minute (11 liters per minute) is satisfactory. Replace electric fuel pump if rate of flow is less than 3 gallons per minute (11 liters per minute).

NOTE

Follow-on maintenance: Install intermediate rear left center floor plate (see WP 0302 00).

END OF WORK PACKAGE

UNIT MAINTENANCE
RECOVERY VEHICLE, FULL TRACKED: MEDIUM, M88A1
NSN 2350-00-122-6826, EIC AQA
FUEL TRANSFER PUMP HOSES AND RELATED PARTS REPLACEMENT
REMOVAL, INSTALLATION

INITIAL SETUP:**Tools and Special Tools**

Tool kit, general mechanic's (item 59, WP 0490 00)

Equipment Condition

Right rear air inlet door opened (see WP 0341 00)

Materials/Parts

Tape, sealant (item 34, WP 0489 00)

Lockwashers (4) (item 638, WP 0491 00)

Screws (4) (item 372, WP 0491 00)

WARNING

Do not smoke or use open flame when working on fuel system: explosion may occur, causing severe injury or death.

Removal

1. Remove screw (1), lockwasher (2), and clamp (3) from hose (4).
2. Remove two screws (5), two lockwashers (6), and strap (7).
3. Remove nipple (8) and nut (9) from hose (4).
4. Remove hose (4) with elbow (10) and nipple (11) from pump assembly (12).
5. Remove elbow (10) and nipple (11) from hose (4).
6. Remove screw (13), lockwasher (14), and clamp (15) from hose (16).
7. Remove elbow (17) from hose (16).
8. Remove hose (16) with elbow (18) from pump assembly (12).
9. Remove elbow (18) from hose (16).

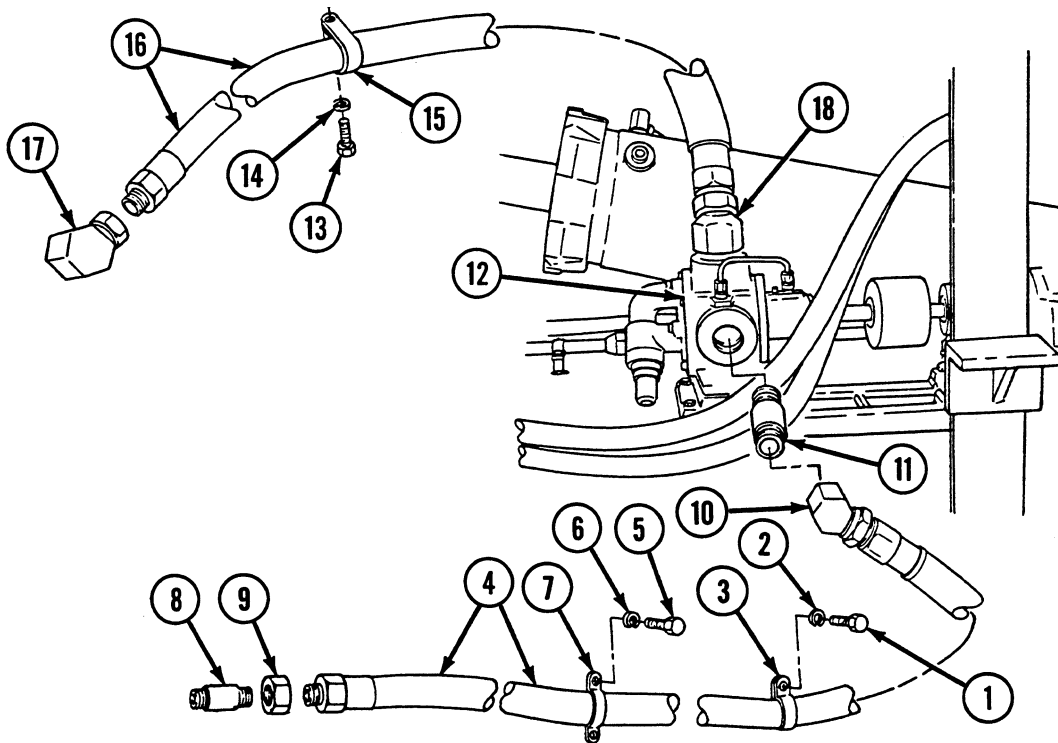

Installation

1. Install elbow (18) to hose (16).
2. Install hose (16) with elbow (18) to pump assembly (12) using adhesive tape.
3. Install elbow (17) to hose (16).
4. Install elbow (10) and nipple (11) to hose (4).
5. Install clamp (15) with lockwasher (14) and screw (13) to hose (16).
6. Install hose (4) with elbow (10) and nipple (11) to pump assembly (12) using adhesive tape.
7. Install nut (9) and nipple (8) to hose (4) using adhesive tape.
8. Install strap (7) with two lockwashers (6) and two screws (5).
9. Install clamp (3), lockwasher (2), and screw (1) to hose (4).

NOTE

Follow-on maintenance: Close right rear air inlet door (see WP 0341 00).

END OF WORK PACKAGE

UNIT MAINTENANCE
RECOVERY VEHICLE, FULL TRACKED: MEDIUM, M88A1
NSN 2350-00-122-6826, EIC AQA
FUEL PUMP (GEAR TYPE), LINES, AND RELATED PARTS MAINTENANCE
REMOVAL, INSTALLATION, TESTING

INITIAL SETUP:**Tools and Special Tools**

Tool kit, general mechanic's (item 59, WP 0490 00)
STE/ICE-R kit (item 57, WP 0490 00)

References

WP 0040 00

Materials/Parts

Gasket (item 257, WP 0491 00)
Nuts (4) (item 153, WP 0491 00)
Nuts, self-locking (2) (item 492, WP 0491 00)
Washers, flat (4) (item 152, WP 0491 00)

Equipment Condition

Powerplant removed for access to fuel pump (see WP 0098 00)

WARNING

Do not smoke or use open flame when working on fuel system: explosion may occur, causing severe injury or death.

Removal

1. Remove fuel inlet hose (1) by loosening union nuts at each end and removing clamp (2) and nut (3).
2. Remove fuel outlet hose (4) by loosening union nuts at each end and removing two clamps (5) and nut (6).
3. Remove two nipples (7) and two elbows (8) from fuel pump (9).
4. Remove fuel pump (9) and gasket (10) by removing four nuts (11) and four flat washers (12).

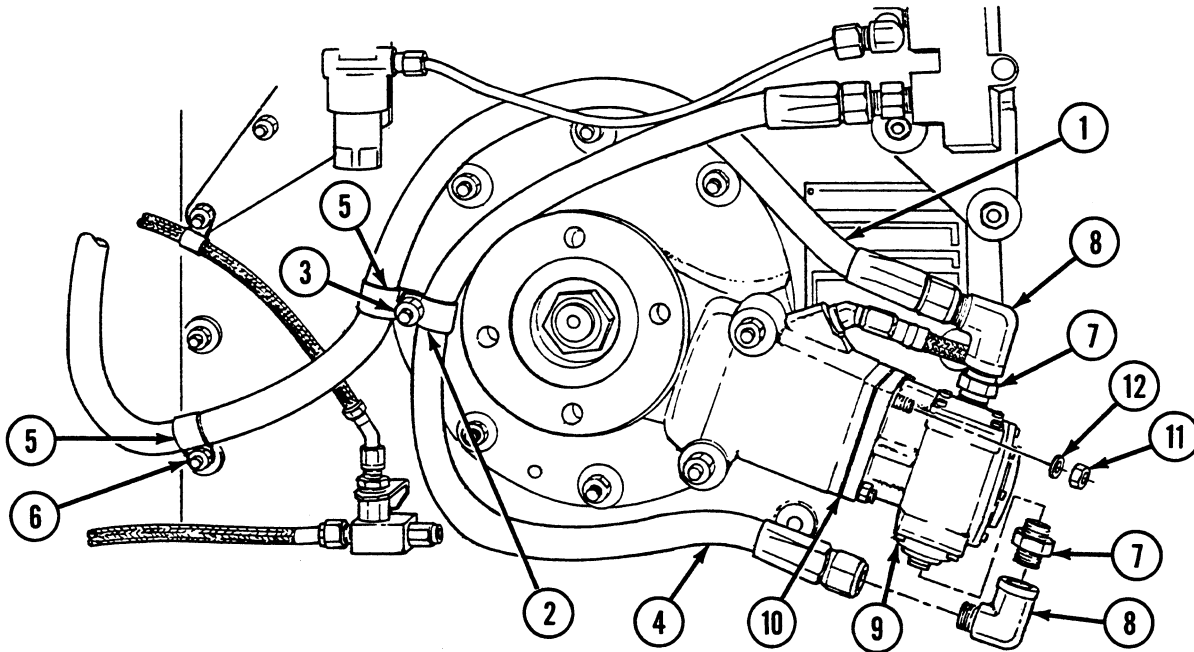

Installation

1. Install fuel pump (9) and gasket (10) with four nuts (11) and four flat washers (12).
2. Install two nipples (7) and two elbows (8) to fuel pump (9).
3. Install fuel outlet hose (4) by tightening union nuts at each end and installing two clamps (5) and nut (6).
4. Install fuel inlet hose (1) by tightening union nuts at each end and installing clamp (2) and nut (3).

Testing

1. Check fuel/water separator filter cover bleeder valve and primary fuel filter cover bleeder valve for fuel pressure by performing STE/ICE-R test 50 (see WP 0040 00) with pressure transducer.

NOTE

Follow-on maintenance: Install powerplant (see WP 0098 00).

END OF WORK PACKAGE

UNIT MAINTENANCE
RECOVERY VEHICLE, FULL TRACKED: MEDIUM, M88A1
NSN 2350-00-122-6826, EIC AQA
FUEL INJECTOR FUEL RETURN HOSE REPLACEMENT
REMOVAL, INSTALLATION

INITIAL SETUP:**Tools and Special Tools**

Tool kit, general mechanic's (item 59, WP 0490 00)
Pliers, retaining ring, external (item 38, WP 0490 00)

Materials/Parts (cont.)

Washer, flat (item 544, WP 0491 00)

Materials/Parts

Lockwasher (item 627, WP 0491 00)
Nuts, self-locking (3) (item 497, WP 0491 00)
Ring, retaining (item 452, WP 0491 00)
Screws (3) (item 594, WP 0491 00)

Equipment Condition

Engine right and left upper covers removed (see WP 0115 00)
Engine cooling fan shroud and related parts removed (see WP 0146 00)

WARNING

Do not smoke or use open flame when working on fuel system: explosion may occur, causing severe injury or death.

Removal

1. Remove 10 hose assemblies (1) by loosening coupling nut at each end of hose assembly.
2. Remove two hose assemblies (2) by loosening coupling nut at each end of hose assembly.
3. Remove hose assembly (3) by loosening coupling nut at each end of hose assembly.
4. Remove 12 multiple connectors (4) by removing 12 fluid passage bolts (5) and 24 flat washers (6).
5. Remove tube assembly (7) and tube elbow (8) by loosening coupling nut at each end of tube assembly and removing two clamps (9).
6. Remove tube assembly (10) and tube elbow (11) by loosening coupling nut at each end of tube assembly and removing two clamps (12).
7. Remove hose assembly (13) by loosening coupling nut at each end of hose assembly.
8. Remove grommet (14) and two elbows (15).
9. Remove hose assembly (16) by loosening coupling nut at each end of hose assembly.
10. Remove retaining ring (17), nut (18), clinch sleeve (19), and sealing plug (20).
11. Remove tube cross (21), flat washer (22), and nut (23).
12. Remove three loop clamps (24) by removing three self-locking nuts (25) and three screws (26).
13. Remove hose assembly (27) by loosening coupling nut at each end and removing nut (28), lockwasher (29), and flat washer (30).
14. Remove hose assembly (31) by loosening coupling nut at each end and removing elbow (32) and check valve (33) from one end, and tee (34) from other end.

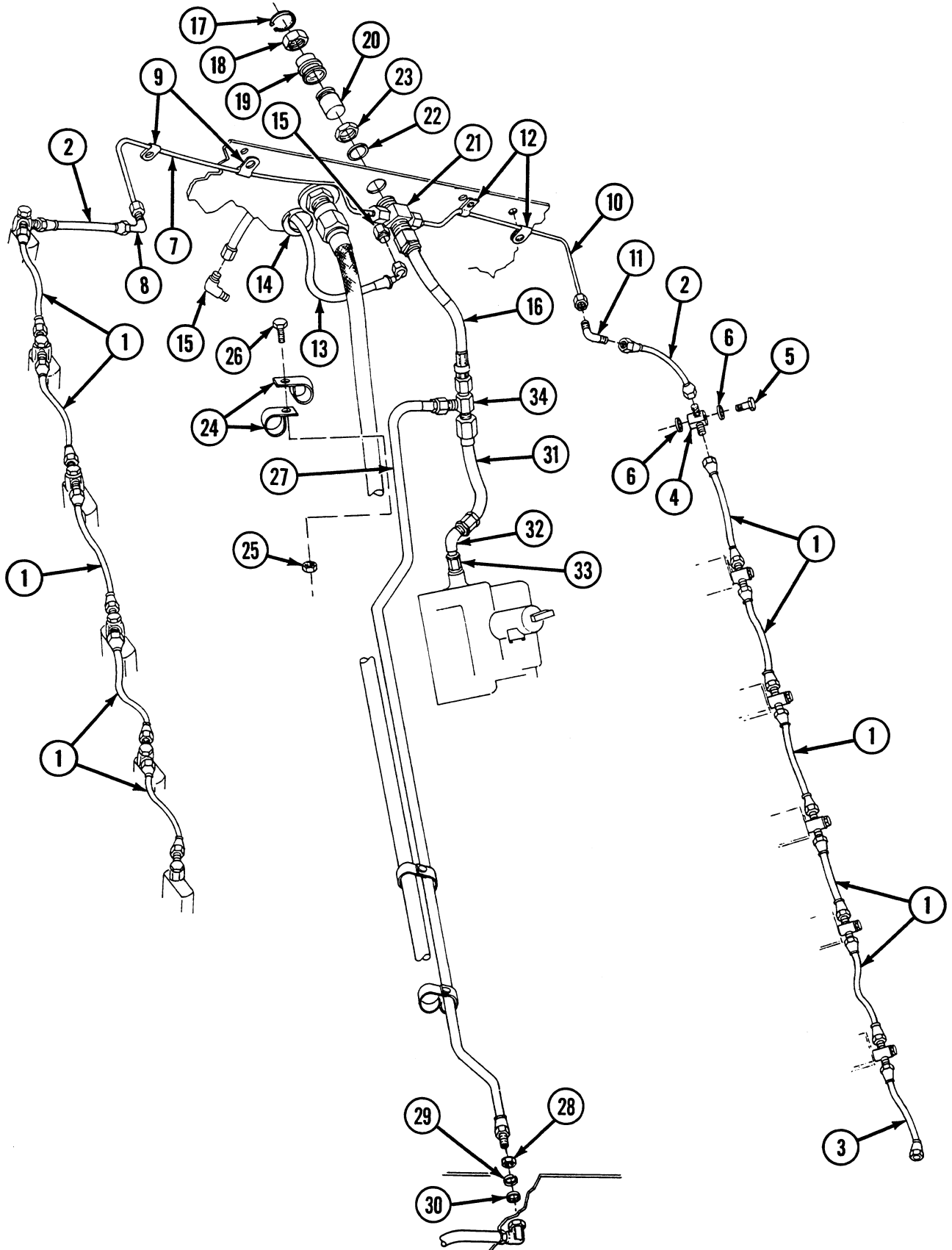

Installation**NOTE**

When tightening fuel line fittings, draw nut up 1/16 (minimum) to 1/3 (maximum) of a turn after seating sleeve.

1. Install hose assembly (31) by tightening coupling nut at each end and installing elbow (32) and check valve (33) on one end, and tee (34) on other end.
2. Install hose assembly (27) by tightening coupling nut at each end and installing nut (28), lockwasher (29), and flat washer (30).
3. Install three loop clamps (24) with three self-locking nuts (25) and three screws (26).
4. Install tube cross (21) with flat washer (22) and nut (23).
5. Install sealing plug (20) with retaining ring (17), nut (18), and clinch sleeve (19).
6. Install hose assembly (16) by tightening coupling nut at each end of hose assembly.
7. Install two elbows (15) and grommet (14).
8. Install hose assembly (13) by tightening coupling nut at each end of hose assembly.
9. Install tube elbow (11) and tube assembly (10) by tightening coupling nut at each end of tube assembly and installing two clamps (12).
10. Install tube elbow (8) and tube assembly (7) by tightening coupling nut at each end of tube assembly and installing two clamps (9).
11. Install 12 multiple connectors (4) with 24 flat washers (6) and 12 fluid passage bolts (5).
12. Install hose assembly (3) by tightening coupling nut at each end of hose assembly.
13. Install two hose assemblies (2) by tightening coupling nut at each end of hose assembly.
14. Install 10 hose assemblies (1) by tightening coupling nut at each end of hose assembly.

NOTE

Follow-on maintenance: Install engine cooling fan shroud and related parts (see WP 0146 00); Install engine right and left upper covers (see WP 0115 00).

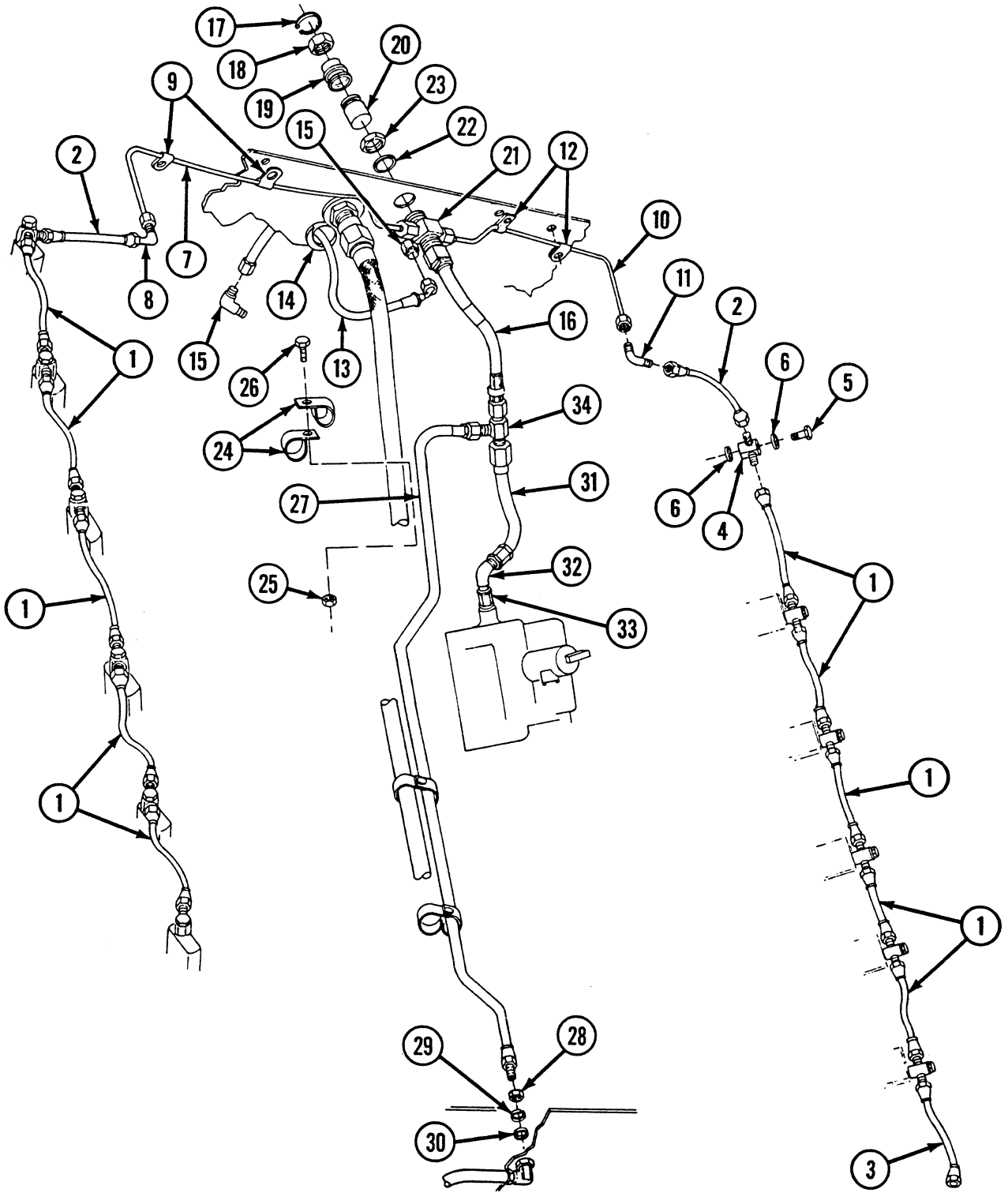

END OF WORK PACKAGE

UNIT MAINTENANCE
RECOVERY VEHICLE, FULL TRACKED: MEDIUM, M88A1
NSN 2350-00-122-6826, EIC AQA
FUEL FILLER TUBE AND FILLER STRAINER MAINTENANCE
REMOVAL, DISASSEMBLY, CLEANING, ASSEMBLY, INSTALLATION

INITIAL SETUP:**Tools and Special Tools**

Tool kit, general mechanic's (item 59, WP 0490 00)

Materials/Parts

Solvent, dry-cleaning (item 9, WP 0489 00)
Gasket (item 237, WP 0491 00)
Gaskets (2) (item 238, WP 0491 00)
Gasket (item 239, WP 0491 00)
Gasket (item 240, WP 0491 00)

Materials/Parts (cont.)

Lockwashers (12) (item 638, WP 0491 00)
Nuts (6) (item 763, WP 0491 00)
Screws (6) (item 370, WP 0491 00)
Screws (6) (item 372, WP 0491 00)
Screws (8) (item 561, WP 0491 00)

Equipment Condition

Grille doors removed (see WP 0342 00)

WARNING

Do not smoke or use open flame when working on fuel system: explosion may occur, causing severe injury or death.

Removal

1. Open fuel fill cover (1).
2. Remove fuel filler tube cap assembly (2).
3. Remove filler tube grommet assembly (3).

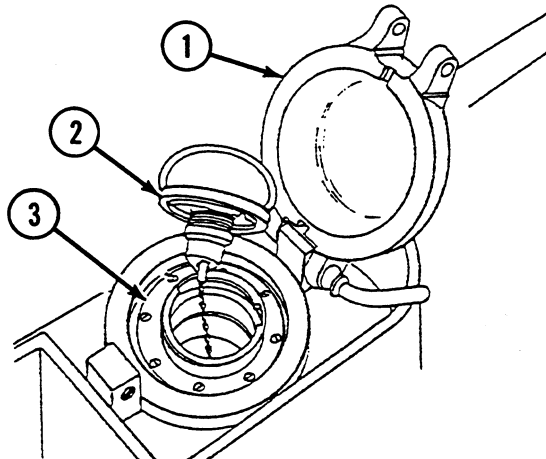

4. Remove upper filler tube (4) and gasket (5) by removing six screws (6), six lockwashers (7), and six nuts (8).
5. Disconnect two air vent lines (9).
6. Remove lower filler tube (10) and gasket (11) by removing six screws (12) and six lockwashers (13).
7. Remove spacer (14) and gasket (15).
8. Remove fuel filler strainer element (16) from fuel tank.

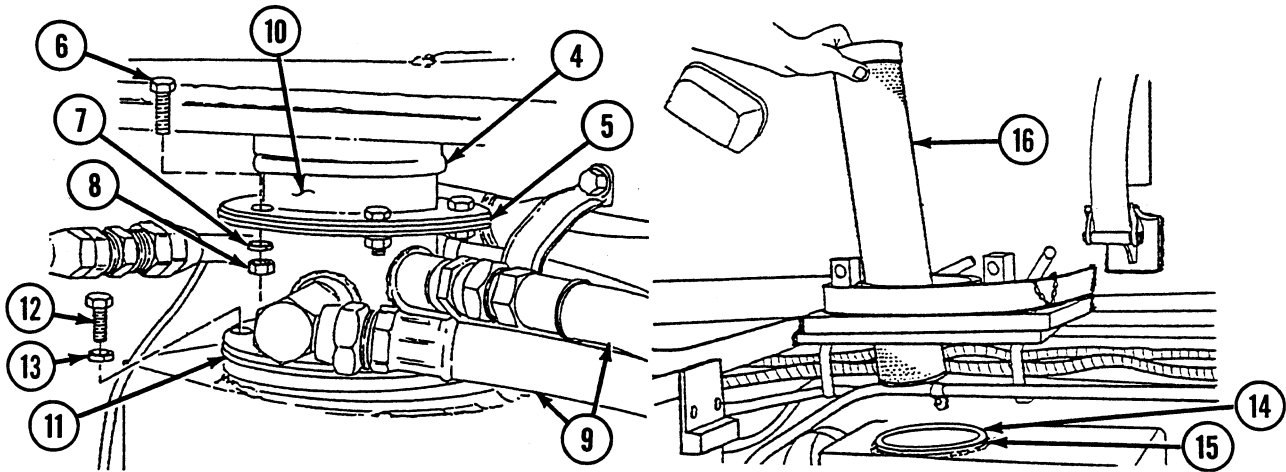

Disassembly

1. Disassemble filler tube grommet assembly (3) by removing eight screws (17), spacer plate (18), gaskets (19 and 20), and spacer plate (21).

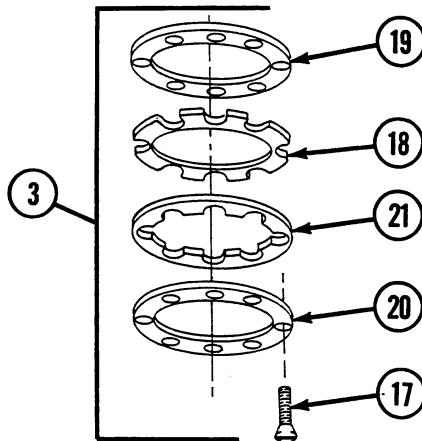

Cleaning

WARNING

Solvents can burn easily, give off harmful vapors, and are harmful to skin and clothing. To avoid injury or death, keep away from open flame and use in a well-ventilated area. If solvent gets on skin or clothing, wash immediately with soap and water.

1. Clean fuel filler strainer element (16) with cleaning compound.

Assembly

NOTE

If replacing gasket (19), cut an approximate 2 inch (in.) (51 millimeter [mm]) length from gasket using old gasket as guide.

1. Assemble filler tube grommet assembly (3) by installing spacer plate (18), two gaskets (19 and 20), spacer plate (21), and eight screws (17).

Installation

1. Install fuel filler strainer element (16) into fuel tank.
2. Install gasket (15) and spacer (14).
3. Install lower filler tube (10) with gasket (11) by installing six lockwashers (13) and six screws (12).
4. Connect two air vent lines (9).
5. Install upper filler tube (4) with gasket (5) by installing six nuts (8), six lockwashers (7), and six screws (6).
6. Install filler tube grommet assembly (3).
7. Install fuel filler tube cap assembly (2).
8. Close fuel fill cover (1).

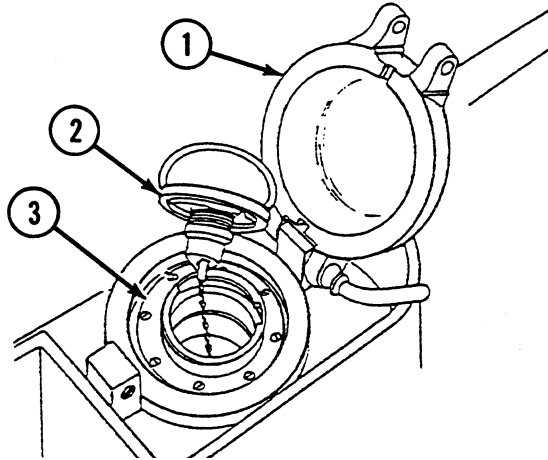

NOTE

Follow-on maintenance: Install grille doors (see WP 0342 00).

END OF WORK PACKAGE

UNIT MAINTENANCE
RECOVERY VEHICLE, FULL TRACKED: MEDIUM, M88A1
NSN 2350-00-122-6826, EIC AQA

FUEL LEVEL TRANSMITTER REPLACEMENT
REMOVAL, INSTALLATION

INITIAL SETUP:**Tools and Special Tools**

Tool kit, general mechanic's (item 59, WP 0490 00)

Equipment Condition

Stowage basket center left floor plate removed (see WP 0299 00)

Engine deck removed (see WP 0336 00)

Materials/Parts

Gaskets (2) (item 16, WP 0491 00)

Lockwashers (12) (item 638, WP 0491 00)

Screws (20) (item 372, WP 0491 00)

WARNING

Do not smoke or use open flame when working on fuel system: explosion may occur, causing severe injury or death.

NOTE

Removal and installation procedures are the same for both the engine compartment and cab.

NOTE

Transmitter removal pertains to the right rear and forward fuel tanks only.

Removal

1. Remove connector (1).
2. Remove transmitter (2) by removing four screws (3).
3. Remove adapter (4) and gasket (5) by removing six screws (6) and six lockwashers (7).

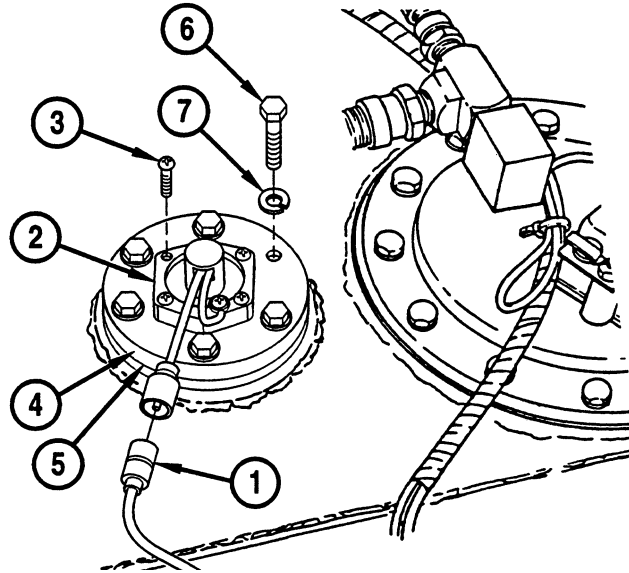
**Installation**

1. Install adapter (4) with gasket (5) by installing six lockwashers (7) and six screws (6) onto fuel tank.
2. Install transmitter (2) with four screws (3) and connect connector (1).

NOTE

Follow-on maintenance: Install engine deck (see WP 0336 00); Install stowage basket center left floor plate (see WP 0299 00).

END OF WORK PACKAGE

UNIT MAINTENANCE
RECOVERY VEHICLE, FULL TRACKED: MEDIUM, M88A1
NSN 2350-00-122-6826, EIC AQA

PURGE PUMP/HANDLE/LEVER MAINTENANCE
REMOVAL, DISASSEMBLY, ASSEMBLY, INSTALLATION

INITIAL SETUP:**Tools and Special Tools**

Tool kit, general mechanic's (item 59, WP 0490 00)

Materials/Parts

Bushing (item 62, WP 0491 00)
 Lockwasher (item 621, WP 0491 00)
 Lockwasher (item 637, WP 0491 00)
 Lockwashers (4) (item 640, WP 0491 00)
 Lockwasher (item 645, WP 0491 00)
 Nut (item 688, WP 0491 00)

Materials/Parts (cont.)

Pins, cotter (3) (item 515, WP 0491 00)
 Pins, straight (3) (item 708, WP 0491 00)
 Screw (item 578, WP 0491 00)
 Screw (item 776, WP 0491 00)
 Screws (4) (item 800, WP 0491 00)

References

TM 9-2350-256-10

WARNING

Do not smoke or use open flame when working on fuel system: explosion may occur, causing severe injury or death.

NOTE

Push in manual fuel shutoff and turn fuel pump switch to OFF position to shut off fuel to purge pump.

NOTE

Push in fuel shutoff handle, start engine (refer to TM 9-2350-256-10), and check for leaks.

NOTE

Handle can be repaired without removing purge pump.

Removal

1. Disconnect two electrical connectors (1).
2. Disconnect fuel line at coupling (2) and fuel line at nipple (3) from purge pump assembly (4).
3. Remove purge pump assembly (4) from mounting bracket (5) by removing four screws (6), four lockwashers (7), and clamp (8).
4. Remove clamp (9) by removing screw (10) and lockwasher (11).

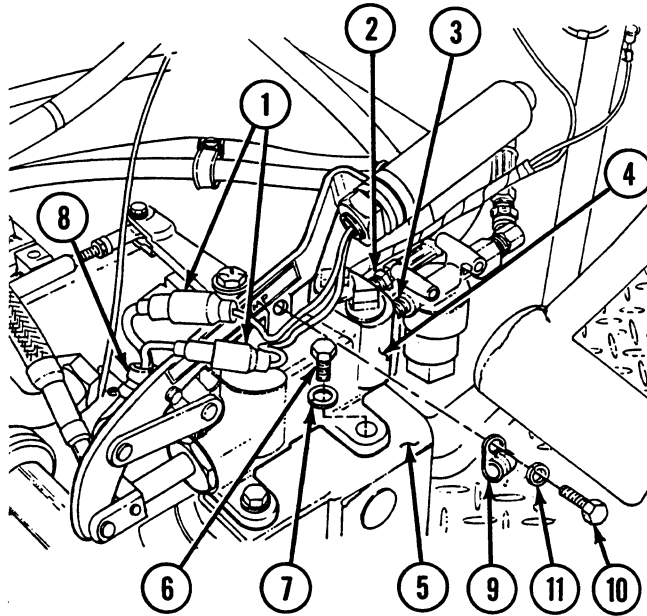

Disassembly

1. Remove lever (12) from purge pump assembly (4) by removing two cotter pins (13) and two straight pins (14).
2. Remove lever bracket (15) by removing cotter pin (16) and straight pin (17).
3. Remove nut (18), lockwasher (19), and handle assembly (20).
4. Remove screw (21) and lockwasher (22) from handle assembly (20).
5. Remove bushing (23) and push button (24) from handle assembly (20).
6. Remove switch (25) from connector (26).

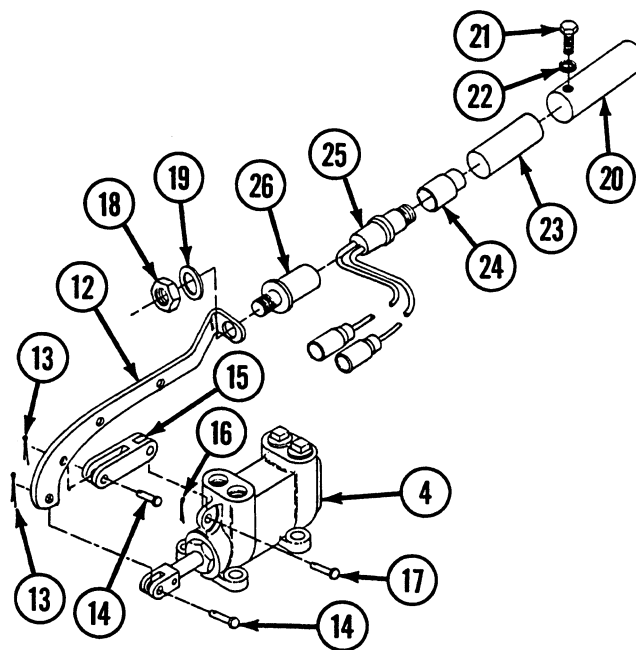

Assembly

1. Slide switch (25) into connector (26).
2. Install push button (24) and bushing (23) into handle assembly (20).
3. Install handle assembly (20) onto connector (26) with lockwasher (22) and screw (21).
4. Install handle assembly (20) with lockwasher (19) and nut (18).
5. Install lever (12) to purge pump assembly (4) with two straight pins (14) and two cotter pins (13).
6. Install lever bracket (15) with straight pin (17) and cotter pin (16).

Installation

1. Install purge pump assembly (4) to mounting bracket (5) with clamp (8), four lockwashers (7), and four screws (6).
2. Install clamp (9) with screw (10) and lockwasher (11).
3. Connect fuel line at coupling (2) and fuel line at nipple (3) to purge pump assembly (4).
4. Connect two electrical connectors (1).

END OF WORK PACKAGE

UNIT MAINTENANCE
RECOVERY VEHICLE, FULL TRACKED: MEDIUM, M88A1
NSN 2350-00-122-6826, EIC AQA

FUEL VALVE LINES AND FITTINGS MAINTENANCE
REMOVAL, REPAIR, INSTALLATION

INITIAL SETUP:**Tools and Special Tools**

Tool kit, general mechanic's (item 59, WP 0490 00)

Materials/Parts

Tape, sealant (item 34, WP 0489 00)
 Bushing (item 304, WP 0491 00)
 Bushing (item 855, WP 0491 00)
 Grommet (item 664, WP 0491 00)
 Lockwashers (10) (item 638, WP 0491 00)
 Screws (10) (item 370, WP 0491 00)

Equipment Condition

Fuel tank drain valves opened and fuel tank drained,
 or fuel shutoff valves turned to OFF (refer to TM
 9-2350-256-10)
 Rear center floor plate removed (see WP 0297 00)
 Rear left-side intermediate floor plate removed (see WP
 0298 00)
 Stowage basket center left floor plate removed (see WP
 0299 00)
 Intermediate rear left-side floor plate removed (see WP
 0301 00)
 Toolbox rack removed (see WP 0332 00)

WARNING

Do not smoke or use open flame when working on fuel system: explosion may occur, causing severe injury or death.

NOTE

For installation purposes, parts indicated with an asterisk (*) need sealant tape.

Removal

1. Remove lines and fittings as required using illustration as guide.

Repair or Replacement

1. Clean and dry all lines and fittings.
2. Inspect fuel lines for cracks, bends, twists, or flattened areas.
3. Straighten slightly bent rigid fuel lines. Replace broken or badly bent fuel lines.
4. Replace broken or badly bent flexible fuel lines. Replace frayed, cracked, or defective flexible lines. Replace damaged fittings.
5. Replace defective primary fuel filter (see WP 0129 00).

Installation

1. Install lines and fittings in reverse order using illustration as guide.

NOTE

Follow-on maintenance: Install toolbox rack (see WP 0332 00); Install rear left-side intermediate floor plate (see WP 0301 00); Install stowage basket center left floor plate (see WP 0299 00); Install intermediate rear left-side floor plate (see WP 0298 00); Install rear center floor plate (see WP 0297 00); Close fuel tank drain valves and fill fuel tanks or turn ON fuel shutoff valves (refer to TM 9-2350-256-10).

1 Elbow	29 Elbow
2 Reducer	30 Elbow*
3 Left fuel tank control valve assembly	31 Hose assembly, fuel return from engine port 95*
4 Nipple	32 Coupling
5 Hose assembly, purge pump to fuel vent	33 Coupling (2)
6 Screw (10)	34 Hose assembly, right tank air vent
7 Lockwasher (10)	35 Loop clamp (2)
8 Loop clamp (5)	36 Hose assembly, forward tank air vent from port 94
9 Loop clamp (7)	37 Elbow
10 Hose assembly, fuel line to personnel heater	38 Coupling*
11 Elbow*	39 Grommet
12 Connecting ring	40 Bushing
13 Bushing*	41 Coupling
14 Coupling*	42 Tee*
15 Coupling*	43 Coupling
16 Hose assembly, fuel line to APU	44 Coupling
17 Hose assembly, auxiliary power unit (APU) fuel return	45 Hose assembly, forward tank vent
18 Elbow*	46 Loop Clamp
19 Tube assembly*	47 Elbow
20 Elbow	48 Elbow
21 Connecting ring	49 Hose assembly, forward tank to engine at port 96
22 Coupling	50 Reducer*
23 Hose assembly, port 96 to engine	51 Tee*
24 Elbow	52 Hose assembly, fuel return from engine port 95
25 Coupling	53 Reducer*
26 Connecting ring	54 Hose assembly, purge pump to bulkhead
27 Hose assembly, purge pump to engine at port 97	55 Coupling
28 Elbow	

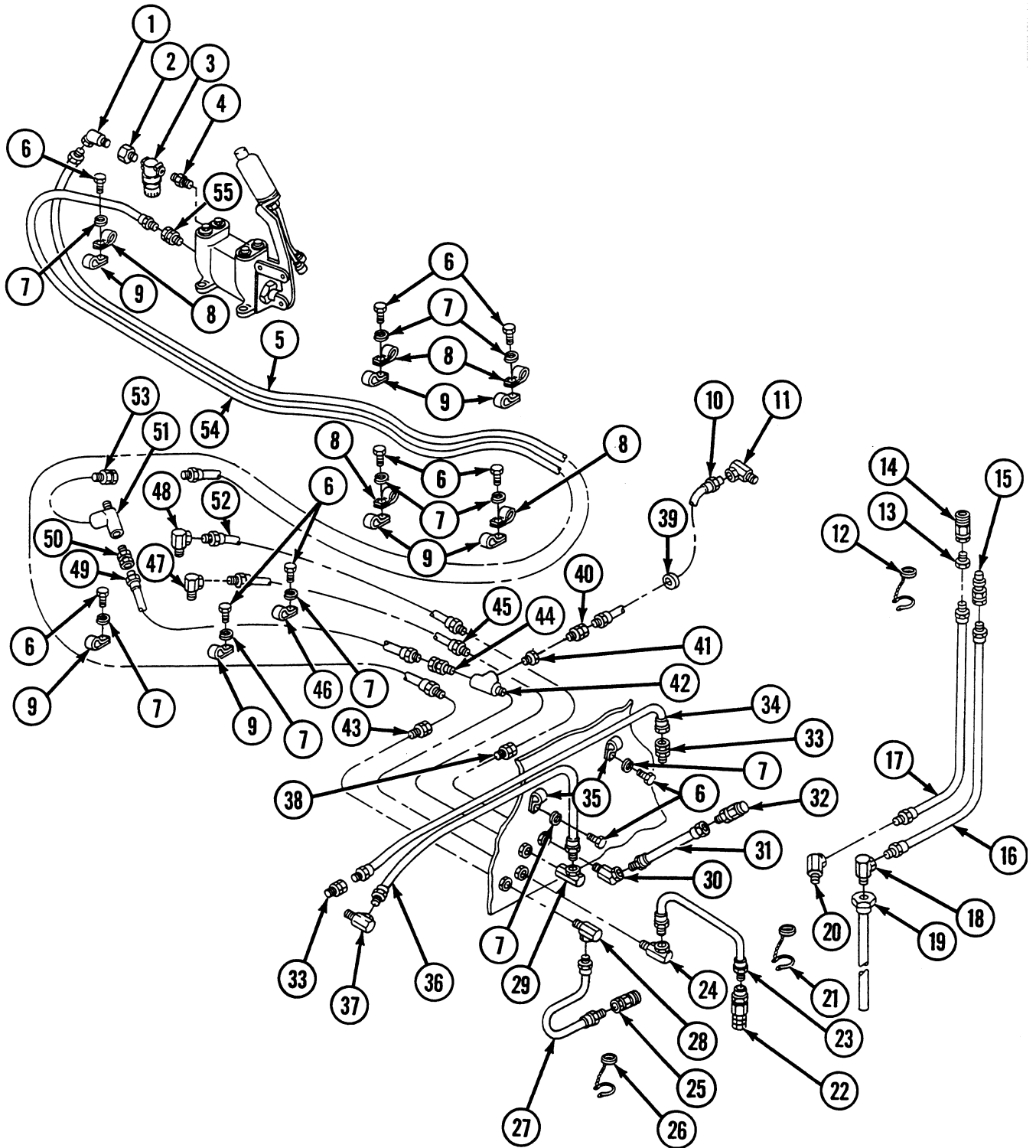

END OF WORK PACKAGE

UNIT MAINTENANCE
RECOVERY VEHICLE, FULL TRACKED: MEDIUM, M88A1
NSN 2350-00-122-6826, EIC AQA
ENGINE FUEL MANUAL SHUTOFF CONTROL MAINTENANCE
REMOVAL, INSTALLATION, ADJUSTMENT

INITIAL SETUP:**Tools and Special Tools**

Tool kit, general mechanic's (item 59, WP 0490 00)

Materials/Parts

Tape, sealant (item 34, WP 0489 00)
 Grommet (item 664, WP 0491 00)
 Lockwashers (4) (item 626, WP 0491 00)
 Lockwasher (item 621, WP 0491 00)
 Lockwashers (9) (item 638, WP 0491 00)
 Lockwashers (2) (item 640, WP 0491 00)
 Nuts (2) (item 682, WP 0491 00)
 Nuts (5) (item 686, WP 0491 00)
 Nuts (5) (item 687, WP 0491 00)
 Nut (item 723, WP 0491 00)

Materials/Parts (cont.)

Screws (9) (item 370, WP 0491 00)
 Screws (2) (item 721, WP 0491 00)
 Screw (item 731, WP 0491 00)
 Packing, preformed (item 551, WP 0491 00)
 Pins, cotter (2) (item 108, WP 0491 00)
 Washer, flat (item 65, WP 0491 00)
 Washers, flat (2) (item 128, WP 0491 00)

Equipment Condition

Fuel tank drain valves opened and fuel tank drained,
 or fuel shutoff valves turned to OFF (refer to TM
 9-2350-256-10)

WARNING

Do not smoke or use open flame when working on fuel system: explosion may occur, causing severe injury or death.

NOTE

For installation purposes, parts indicated with an asterisk (*) need sealant tape.

Removal

1. Remove lines and fittings as required using illustration as guide.

- | | |
|--|-------------------------|
| 1 Fuel shutoff control handle assembly | 13 Lockwasher (2) |
| 2 Nut (2) | 14 Screw (2) |
| 3 Nut (3) | 15 Screw |
| 4 Nut | 16 Nut* |
| 5 Nut | 17 Flat washer |
| 6 Lockwasher (4) | 18 Preformed packing |
| 7 Fuel shutoff control assembly | 19 Connector |
| 8 Screw (9) | 20 Connecting link |
| 9 Lockwasher (10) | 21 Flat washer (2) |
| 10 Loop clamp (10) | 22 Fuel shutoff control |
| 11 Grommet | 23 Cotter pin (2) |
| 12 Mounting bracket | |

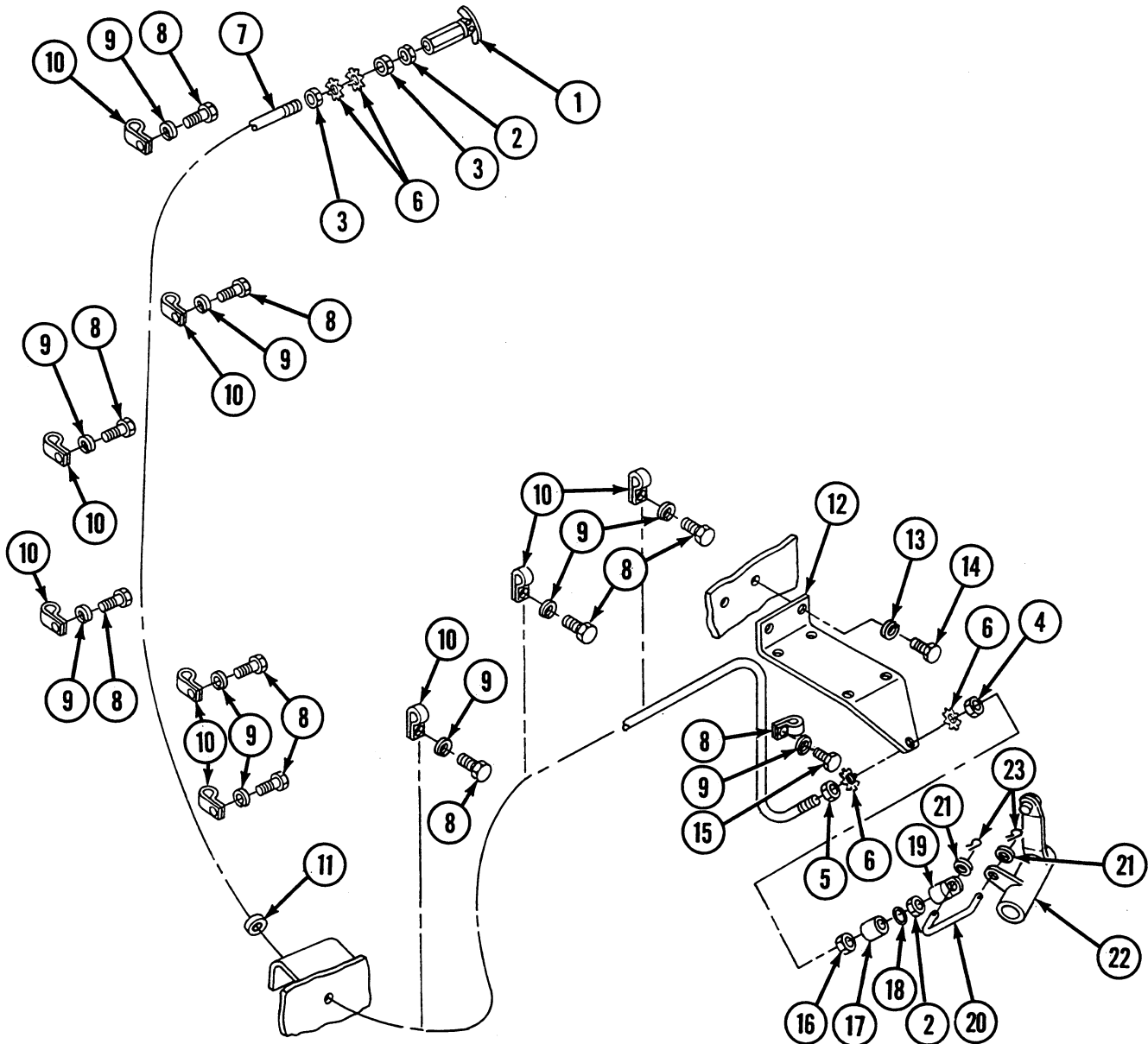

Installation

1. Install controls in reverse order using illustration as guide.

Adjustment

1. Loosen nuts (4 and 5).
2. Pull fuel shutoff handle (1). Check that fuel shutoff control (22) turns to complete "OFF" position. Tighten nut (5).
3. Push fuel shutoff handle (1). Check that fuel shutoff control (22) turns to "ON" position. Tighten nut (4).

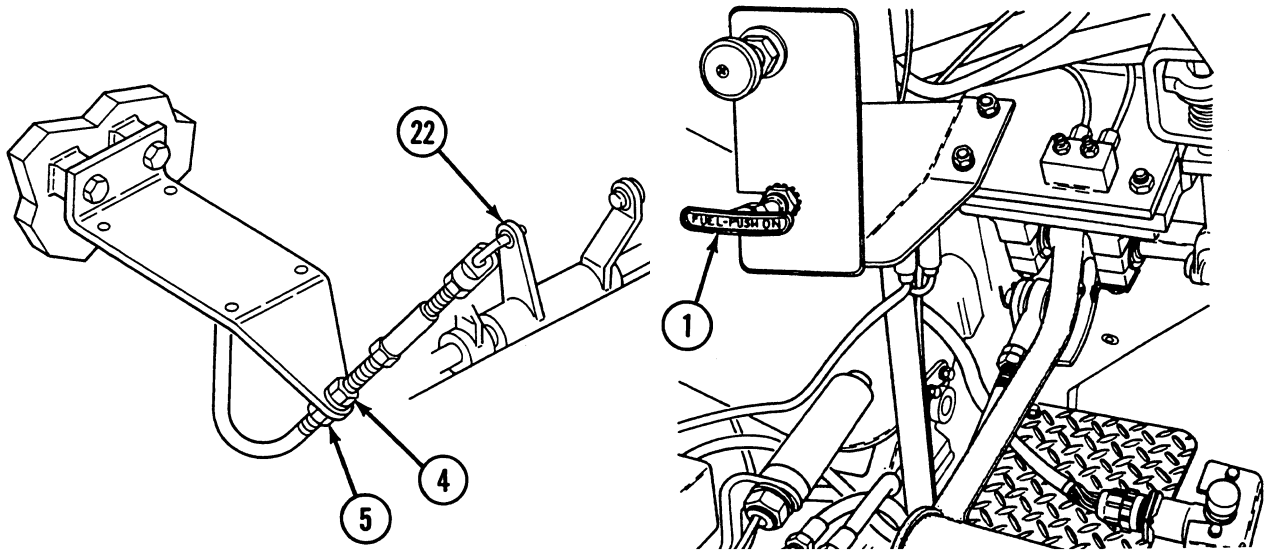

4. Start engine (refer to TM 9-2350-256-10).
5. Check operation of engine fuel manual shutoff control. If control does not shut engine off when operated, repeat adjustment.

NOTE

Follow-on maintenance: Close fuel tank drain valves and fill fuel tank or turn on fuel shutoff valves (refer to TM 9-2350-256-10).

END OF WORK PACKAGE

UNIT MAINTENANCE
RECOVERY VEHICLE, FULL TRACKED: MEDIUM, M88A1
NSN 2350-00-122-6826, EIC AQA

**FUEL CONTROL VALVES AND ID PLATES REPLACEMENT
REMOVAL, INSTALLATION**

INITIAL SETUP:**Tools and Special Tools**

Tool kit, general mechanic's (item 59, WP 0490 00)

Materials/Parts

Tape, sealant (item 34, WP 0489 00)
 Bushings (4) (item 49, WP 0491 00)
 Drivescrews (22) (item 501, WP 0491 00)
 Lockwashers (4) (item 639, WP 0491 00)
 Lockwashers (2) (item 640, WP 0491 00)
 Lockwashers (2) (item 642, WP 0491 00)
 Nuts (4) (item 758, WP 0491 00)
 Nuts (4) (item 768, WP 0491 00)
 Packings, preformed (4) (item 195, WP 0491 00)
 Pins, shoulder (4) (item 48, WP 0491 00)

Materials/Parts (cont.)

Pins, spring (4) (item 448, WP 0491 00)
 Pins, spring (16) (item 472, WP 0491 00)
 Screw (item 415, WP 0491 00)
 Setscrews (4) (item 749, WP 0491 00)
 Washers, flat (5) (item 539, WP 0491 00)
 Washers, flat (4) (item 541, WP 0491 00)

Equipment Condition

Powerplant removed (see WP 0098 00)
 Fuel tank drain valves opened and fuel tank drained,
 or fuel shutoff valves turned to OFF (refer to TM
 9-2350-256-10)

WARNING

Do not smoke or use open flame when working on fuel system: explosion may occur, causing severe injury or death.

NOTE

For installation purposes, parts indicated with an (*) need sealant tape.

Removal

1. Remove lines and fittings as required using illustration as guide.

- | | |
|----------------------------------|--|
| 1 Nut (4) | 30 Nipple (2)* |
| 2 Lockwasher (4) | 31 Check valve* |
| 3 Handwheel (2) | 32 Hose assembly, forward tank main fuel line filler* |
| 4 Flat washer (5) | 33 Nipple |
| 5 Setscrew | 34 Elbow |
| 6 Collar | 35 Pipe plug* |
| 7 Flat washer | 36 Fuel shutoff valve |
| 8 Performed Packing (4) | 37 Hose assembly, left tank main fuel line filler |
| 9 Bushing | 38 Left fuel tank control valve |
| 10 Shouldered shaft | 39 Elbow |
| 11 Spring pin (16) | 40 Control rod |
| 12 Universal joint (5) | 41 Shouldered shaft |
| 13 Control rod | 42 Handwheel |
| 14 Spring pin (4) | 43 Handwheel |
| 15 Shoulder pin (4) | 44 Shouldered shaft |
| 16 Universal joint (2) | 45 Control rod |
| 17 Right fuel tank control valve | 46 Hose assembly, forward tank main fuel line filler and drain |
| 18 Tee (2)* | 47 Elbow |
| 19 Elbow (2)* | 48 Shouldered shaft |
| 20 Hose assembly (2) | 49 Control rod |
| 21 Elbow (2)* | 50 Nipple (2)* |
| 22 Screw | 51 Forward fuel tank control valve |
| 23 Lockwasher (2) | 52 Elbow |
| 24 Bracket | 53 Tee* |
| 25 Nut (4) | 54 Universal joint |
| 26 Lockwasher | 55 ID plate |
| 27 Adapter union* | 56 Identification (ID) plate (4) |
| 28 Elbow | 57 Drivescrew (22) |
| 29 Hookbolt | |

Installation

1. Install fuel control valves and ID plates in reverse order using illustration as guide.

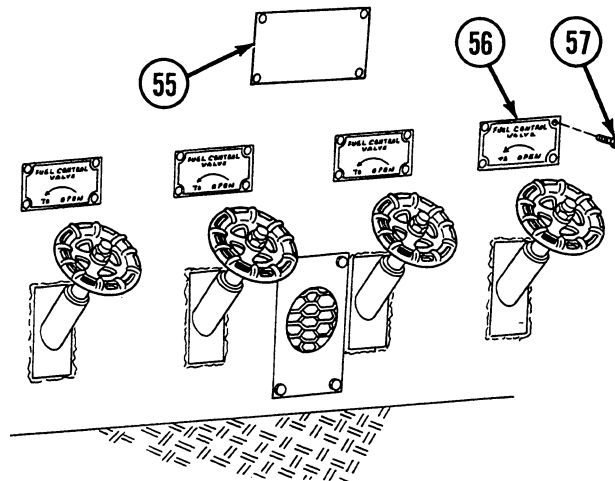

NOTE

Follow-on maintenance: Close fuel tank drain valves and fill fuel tank or turn on fuel shutoff valves (refer to TM 9-2350-256-10); Install powerplant (see WP 0098 00).

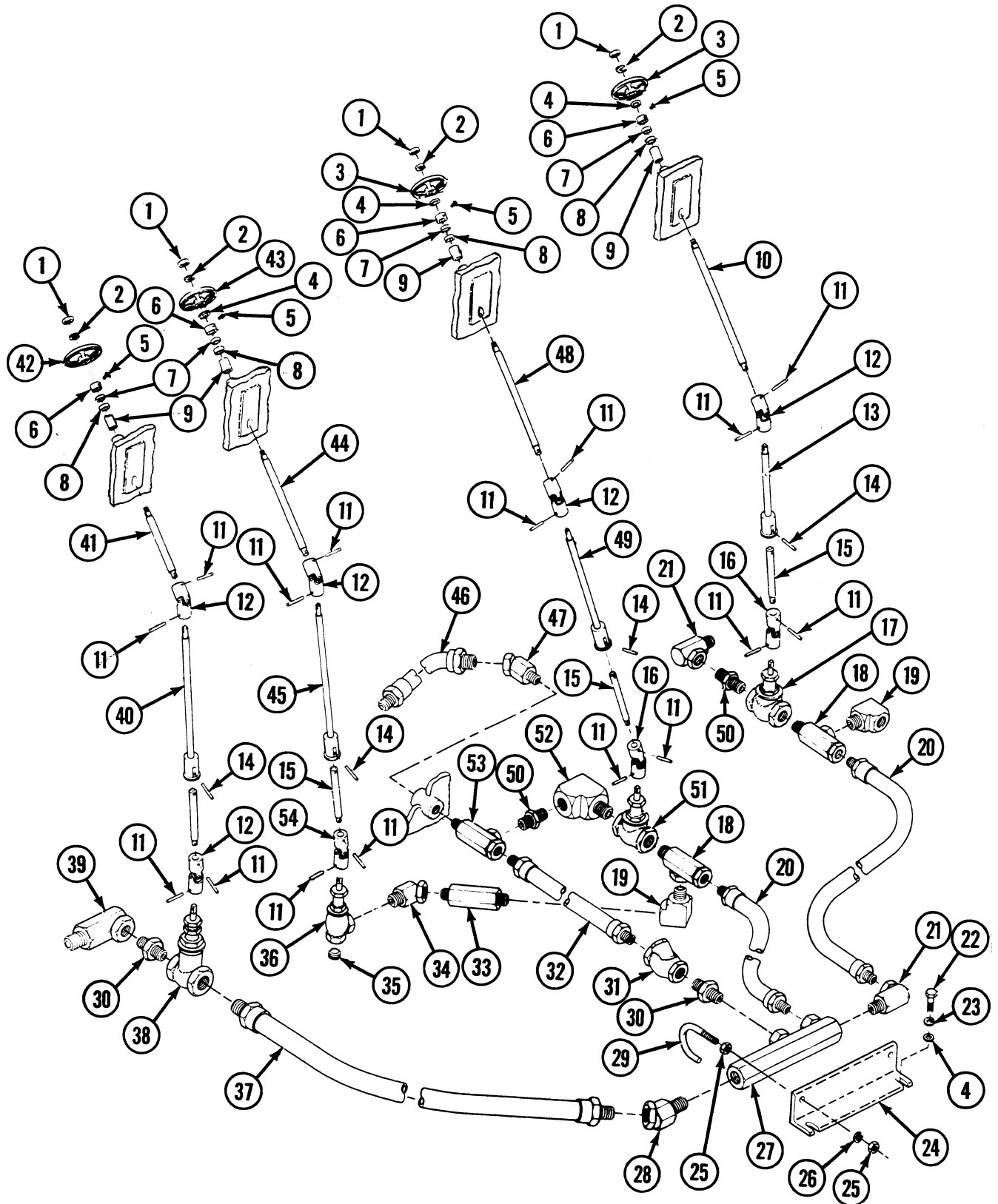

END OF WORK PACKAGE

UNIT MAINTENANCE
RECOVERY VEHICLE, FULL TRACKED: MEDIUM, M88A1
NSN 2350-00-122-6826, EIC AQA

FUEL CHECK VALVE MAINTENANCE
REMOVAL, INSTALLATION, TESTING

INITIAL SETUP:**Tools and Special Tools**

Tool kit, general mechanic's (item 59, WP 0490 00)

Materials/Parts

Bushing (item 854, WP 0491 00)
 Lockwashers (2) (item 638, WP 0491 00)
 Nuts, self-locking (2) (item 492, WP 0491 00)
 Screws (2) (item 378, WP 0491 00)
 Washers, flat (2) (item 328, WP 0491 00)

Materials/Parts (cont.)

Washers, flat (2) (item 358, WP 0491 00)

References

TM 9-2350-256-10

Equipment Condition

Engine deck removed (see WP 0336 00)

WARNING

Do not smoke or use open flame when working on fuel system: explosion may occur, causing severe injury or death.

NOTE

Turn MASTER switch and fuel pump switch to OFF position.

Removal

1. Remove fuel inlet hose (1) from elbows (2 and 3).
2. Remove elbow (2) and adapter (4) from fuel check valve (5).
3. Disconnect fuel pump outlet hose (6) and adapter (7) from fuel check valve (5).
4. Disconnect manifold heater purge fuel line (8) from coupling (9).

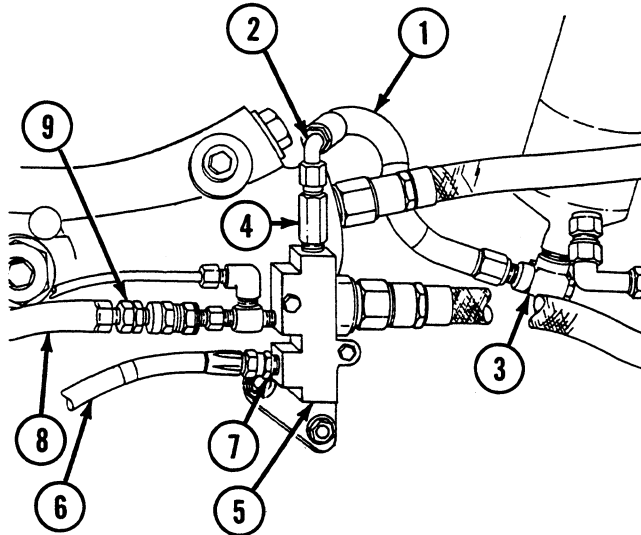

5. Disconnect fuel filter inlet tube (10) and elbow (11) from tee (12).
6. Remove coupling (9), filter (13), bushing (14), and tee (12) from fuel check valve (5).
7. Remove fuel check valve (5) by removing two screws (15), two lockwashers (16), and two flat washers (17).
8. Remove bracket (18) with two nuts (19) and two flat washers (20).

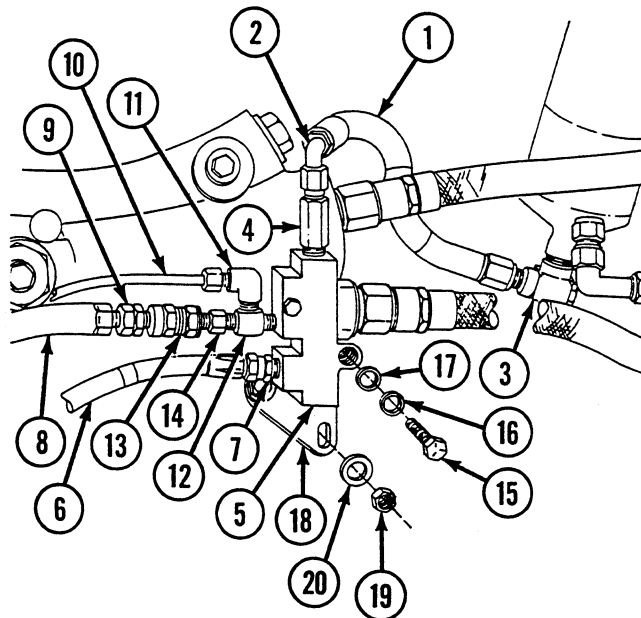

Installation

1. Install bracket (18) with two flat washers (20) and two nuts (19).
2. Install fuel check valve (5) with two screws (15), two lockwashers (16), and two flat washers (17).
3. Install tee (12), bushing (14), filter (13), and coupling (9) to fuel check valve (5).
4. Connect elbow (11) and fuel filter inlet tube (10) to tee (12).
5. Connect manifold heater purge fuel line (8) to coupling (9).
6. Connect fuel pump outlet hose (6) and adapter (7) to fuel check valve (5).
7. Connect adapter (4) and elbow (2) to fuel check valve (5).
8. Connect fuel inlet hose (1) to elbows (2 and 3).

Testing

1. Turn MASTER switch and fuel pump switch to ON position.
2. Purge fuel system (refer to TM 9-2350-256-10).
3. Operate engine (refer to TM 9-2350-256-10). Inspect fuel check valve (5) and connections for leaks.
4. Shut down engine. Turn MASTER switch and fuel pump switch to OFF position.

NOTE

Follow-on maintenance: Install engine deck (see WP 0336 00).

END OF WORK PACKAGE

UNIT MAINTENANCE
RECOVERY VEHICLE, FULL TRACKED: MEDIUM, M88A1
NSN 2350-00-122-6826, EIC AQA
PRIMARY FUEL FILTER MAINTENANCE
SERVICING, REMOVAL, DISASSEMBLY, CLEANING, ASSEMBLY, INSTALLATION

INITIAL SETUP:**Tools and Special Tools**

Tool kit, general mechanic's (item 59, WP 0490 00)
 Suitable container

Materials/Parts

Compound, cleaning (item 9, WP 0489 00)
 Locknut (item 734, WP 0491 00)
 Lockwashers (3) (item 641, WP 0491 00)
 Nut (item 435, WP 0491 00)
 Nut (item 486, WP 0491 00)
 Nuts, self-locking (2) (item 495, WP 0491 00)
 Parts kit, primary fuel filter (item 186, WP 0491 00)
 Screw (item 132, WP 0491 00)

Materials/Parts (cont.)

Screw (item 393, WP 0491 00)
 Screws (2) (item 476, WP 0491 00)
 Screw (item 567, WP 0491 00)
 Screws (2) (item 795, WP 0491 00)
 Spring (item 74, WP 0491 00)
 Washer, flat (item 537, WP 0491 00)
 Washer, flat (item 833, WP 0491 00)

Equipment Condition

Left- and center-front air inlet grilles removed (see WP 0342 00)

WARNING

Do not smoke or use open flame when working on fuel system: explosion may occur, causing severe injury or death.

NOTE

Semiannually, or after 750 miles (1207 kilometers [km]) of vehicle operation, replace primary fuel filter element.

NOTE

When servicing and assembling primary fuel filter, use parts kit.

NOTE

In illustrations powerplant and oil cooler lines removed for clarity only.

Servicing

1. Loosen bleeder valve (1).
2. Remove constant bleed line (2) and drain fuel from fuel filter into suitable container.

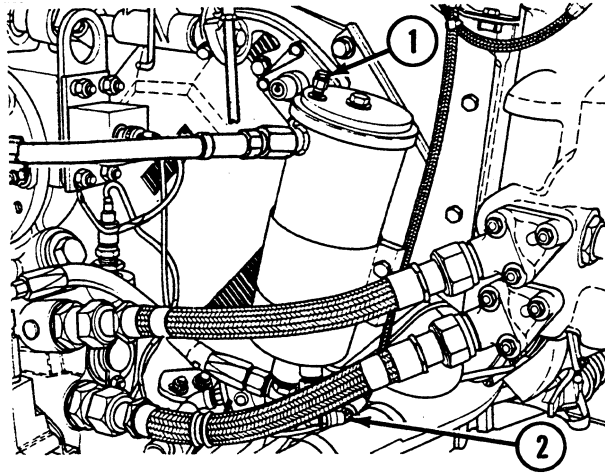

3. Loosen retaining screw (3) and remove fuel filter head (4). Remove and discard filter head gasket (5).

4. Remove fuel filter element (6) from filter body (7). Discard fuel filter element.

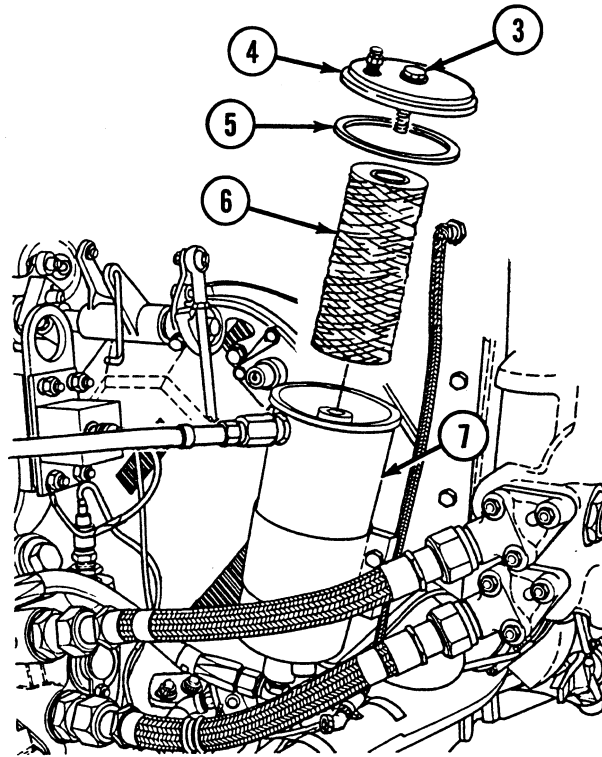

WARNING

Solvents can burn easily, give off harmful vapors, and are harmful to skin and clothing. To avoid injury or death, keep away from open flame and use in a well-ventilated area. If solvent gets on skin or clothing, wash immediately with soap and water.

5. Clean inside of filter body (7) with cleaning compound and stiff brush. Scrape off sludge or gum, if necessary.
6. Attach constant bleed line (2) and install fuel filter element (6).
7. Install fuel filter head (4) using filter head gasket (5), and tighten retaining screw (3).
8. Bleed air from primary fuel filter. Activate electric fuel pump until fuel runs from bleeder valve (1), then tighten bleeder valve.

Removal

1. Loosen bleeder valve (1).
2. Disconnect constant bleed line (2) and drain fuel into suitable container.
3. Remove constant bleed line (2), filter (9), screw (10), clamp (11), nipple (12), lockwasher (13), and locknut (14).
4. Disconnect fuel filter outlet hose (15) and fuel filter inlet hose (16) from primary fuel filter (8).
5. Remove fuel filter inlet hose (16) with coupling (17) by removing screw (18), clamp (19), flat washer (20), and nut (21) from bracket (22).
6. Remove bracket (22) by removing nut (23).
7. Remove two self-locking nuts (24), two screws (25), and primary fuel filter (8) from filter bracket (26).
8. Remove filter bracket (26) by removing two screws (27) and two lockwashers (28).
9. Remove elbow (29) and adapter (30).

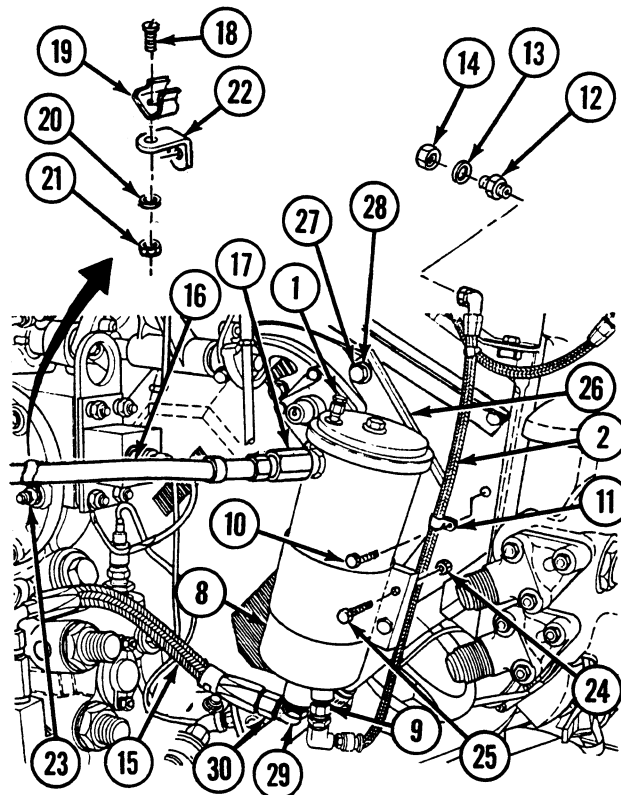

Disassembly

1. Loosen retaining screw (31) and lift off fuel filter head (4). Remove and discard filter head gasket (5).
2. Remove retaining screw (31), flat washer (32), gasket (33), and nut (34) from fuel filter head (4). Discard gasket.
3. Remove bleeder valve (1) from fuel filter head (4).

- Remove and discard fuel filter element (6).

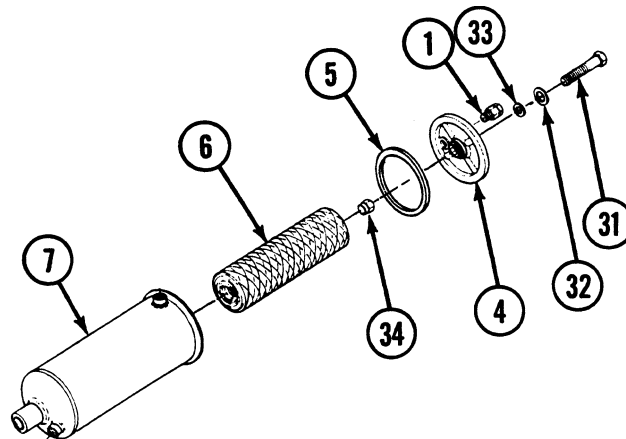

- Remove preformed packing (35), retainer assembly (36), and helical compression spring (37) from filter body (7).

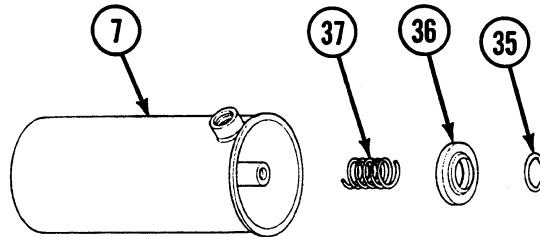

Cleaning

WARNING

Solvents can burn easily, give off harmful vapors, and are harmful to skin and clothing. To avoid injury or death, keep away from open flame and use in a well-ventilated area. If solvent gets on skin or clothing, wash immediately with soap and water.

- Clean all parts with cleaning compound. Scrape off any accumulated sludge or gum. If necessary, dry parts.
- Check filter (9) for blockage. Filter orifice must be open.
- Replace discarded and defective parts.

Assembly

- Install helical compression spring (37) in filter body (7).
- Install preformed packing (35) on retainer assembly (36) and place both in filter body (7).
- Install fuel filter element (6).
- Install bleeder valve (1) in fuel filter head (4).
- Install flat washer (32), gasket (33), nut (34), and retaining screw (31) on fuel filter head (4). Install fuel filter head gasket (5) in fuel filter head.

Installation

1. Install adapter (30) on elbow (29).
2. Install filter bracket (26) with two lockwashers (28) and two screws (27).
3. Install primary fuel filter (8) in filter bracket (26) with two screws (25) and two self-locking nuts (24).
4. Install bracket (22) with nut (23).
5. Install fuel filter inlet hose (16) with coupling (17) on bracket (22) with screw (18), clamp (19), flat washer (20), and nut (21).
6. Connect fuel filter outlet hose (15) and fuel filter inlet hose (16) to primary fuel filter (8).
7. Install constant bleed line (2), filter (9), screw (10), clamp (11), nipple (12), lockwasher (13), and locknut (14).
8. Bleed air from primary fuel filter (8) and fuel lines by loosening bleeder valve (1). Activate electric fuel pump until fuel runs from bleeder valve. Tighten bleeder valve.

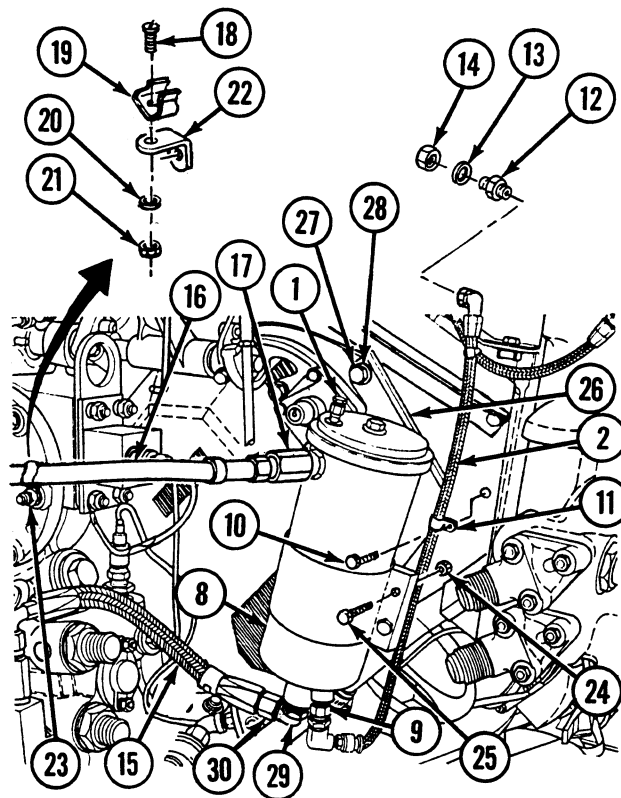

NOTE

Follow-on maintenance: Install left- and center-front air inlet grilles (see WP 0342 00).

END OF WORK PACKAGE

UNIT MAINTENANCE
RECOVERY VEHICLE, FULL TRACKED: MEDIUM, M88A1
NSN 2350-00-122-6826, EIC AQA
FUEL/WATER SEPARATOR FILTER ELEMENTS REPLACEMENT
REMOVAL, INSTALLATION

INITIAL SETUP:**Tools and Special Tools**

Tool kit, general mechanic's (item 59, WP 0490 00)
 Suitable container

Materials/Parts

Filter element, center (final) (item 69, WP 0491 00)
 Filter elements, outer (2) (item 70, WP 0491 00)
 Gasket (item 72, WP 0491 00)

Materials/Parts (cont.)

Lockwashers (8) (item 638, WP 0491 00)
 Screws (8) (item 368, WP 0491 00)
 Washers, flat (8) (item 534, WP 0491 00)

Equipment Condition

Grille doors removed (see WP 0342 00)

WARNING

Do not smoke or use open flame when working on fuel system: explosion may occur, causing severe injury or death.

NOTE

Wipe clean fuel/water separator unit and surrounding area.

NOTE

Semiannually, or after 750 miles (1207 km) of operation, replace two outer fuel/water separator filter elements. Center (final) filter element is normally replaced at engine overhaul only.

NOTE

Do not remove or otherwise disturb center (final) filter element during semiannual outer filter element replacement. If center (final) filter element is removed, it must be replaced.

NOTE

In illustrations powerplant shown removed for clarity only.

Removal

1. Open drain cock (1) and loosen bleeder valve (2). Drain fuel into suitable container.
2. Remove eight screws (3), eight lockwashers (4), and eight flat washers (5). Remove cover (6) and gasket (7) from fuel/water separator unit (8). Discard gasket.

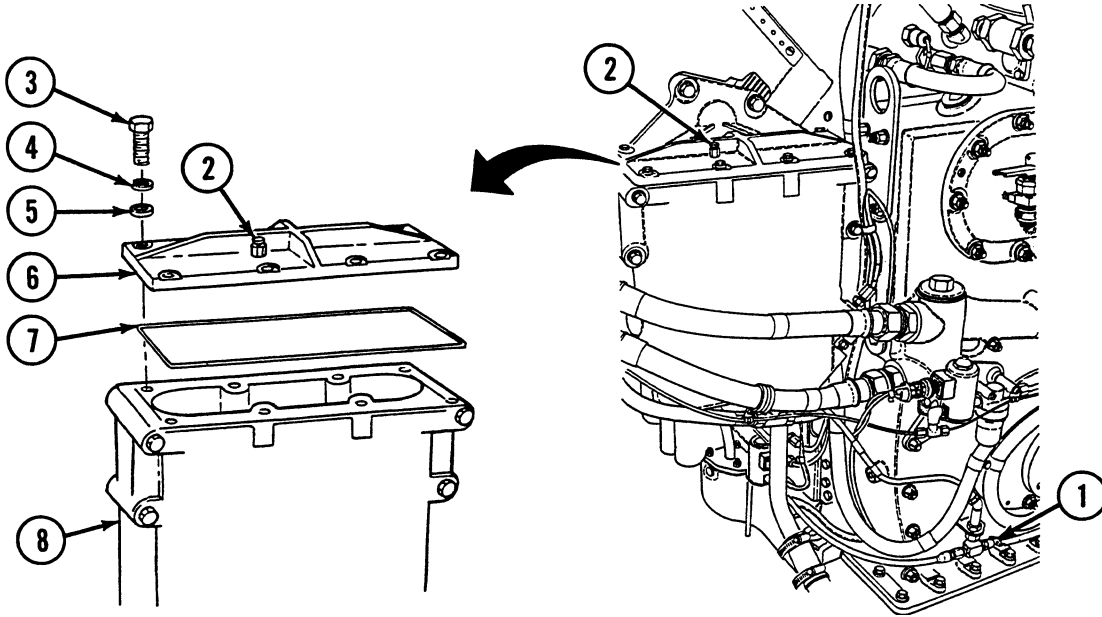

3. Remove and discard two outer filter elements (9) (or if necessary, center [final] filter element [10]). Rotate elements to facilitate removal.

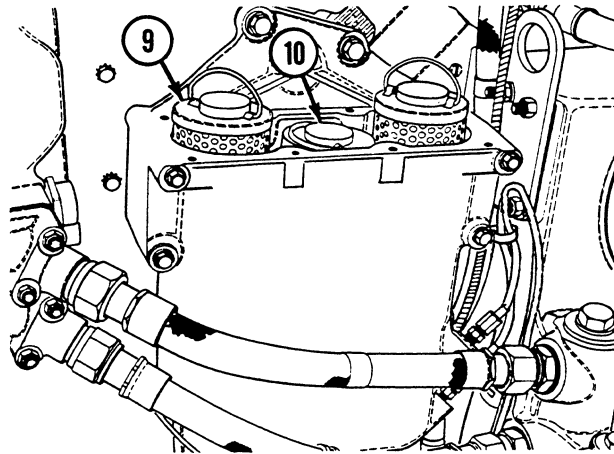

Installation

1. Install two outer filter elements (9).
2. Install gasket (7) and cover (6) with eight screws (3), eight lockwashers (4), and eight flat washers (5).
3. Close drain cock (1). Operate electric fuel pump until fuel flows from bleeder valve (2). Tighten bleeder valve. Check for leaks.

NOTE

Follow-on maintenance: Install grille doors (see WP 0342 00).

END OF WORK PACKAGE

UNIT MAINTENANCE
RECOVERY VEHICLE, FULL TRACKED: MEDIUM, M88A1
NSN 2350-00-122-6826, EIC AQA
FUEL/WATER SEPARATOR FILTER UNIT REPLACEMENT
REMOVAL, INSTALLATION

INITIAL SETUP:**Tools and Special Tools**

Tool kit, general mechanic's (item 59, WP 0490 00)
Suitable container

Materials/Parts

Lockwashers (4) (item 639, WP 0491 00)
Screws (3) (item 476, WP 0491 00)
Screws (2) (item 798, WP 0491 00)

Materials/Parts (cont.)

Screws (2) (item 818, WP 0491 00)
Washers, flat (3) (item 360, WP 0491 00)
Washers, flat (4) (item 843, WP 0491 00)

Equipment Condition

Powerplant removed (see WP 0098 00)

WARNING

Do not smoke or use open flame when working on fuel system: explosion may occur, causing severe injury or death.

Removal

1. Open drain cock (1), loosen bleeder valve (2), and drain fuel into suitable container. Remove bleeder valve.
2. Disconnect fuel outlet hose (3) from tee fitting (4).
3. Disconnect fuel outlet hose (5) from tee fitting (4).

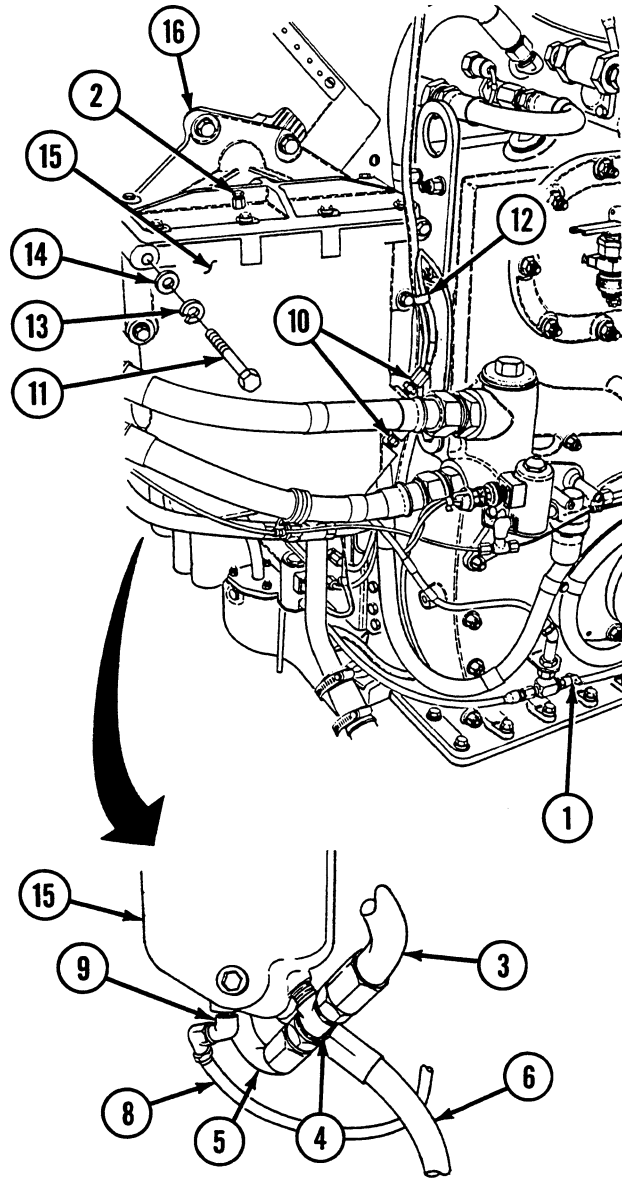

4. Disconnect fuel inlet hose (6) from fuel outlet elbow (7).
5. Disconnect fuel drain hose (8) from fuel drain elbow (9).
6. Disconnect two water level probes (10).
7. Remove four screws (11), clamp (12), four lockwashers (13), and four flat washers (14). Remove fuel/water separator filter unit (15) from mounting bracket (16).
8. Remove tee fitting (4), fuel outlet elbow (7), and fuel drain elbow (9).
9. Remove three screws (17), three flat washers (18), and mounting bracket (16).

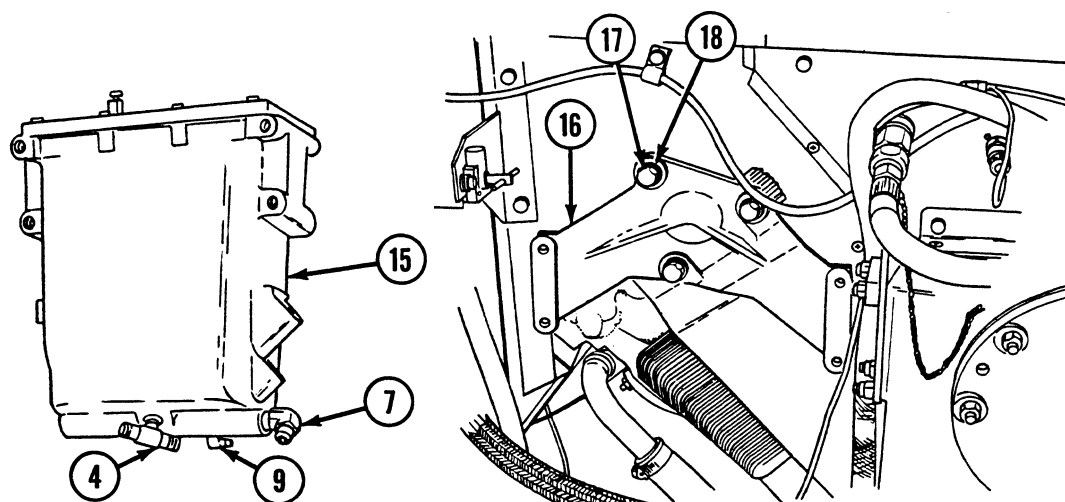

Installation

1. Install mounting bracket (16) with three flat washers (18) and three screws (17).

NOTE

The water level probe that is connected to the lead from the control unit must be installed in the upper location of the fuel/water separator filter.

2. Install two water level probes (10).
3. Install fuel/water separator filter unit (15) onto mounting bracket (16) and secure with four screws (11), clamp (12), four lockwashers (13), and four flat washers (14).
4. If installing fuel/water filter unit (15), remove shipping plug from fuel/water separator cover and install bleeder valve (2) in open position.
5. Install fuel drain elbow (9) and connect fuel drain hose (8).
6. Install tee fitting (4) and connect fuel outlet hoses (5 and 3).
7. Install fuel outlet elbow (7) and connect fuel inlet hose (6).
8. Close drain cock (1) and activate electric fuel pump until fuel flows from bleeder valve (2). Tighten bleeder valve.

NOTE

Follow-on maintenance: Install powerplant (see WP 0098 00).

END OF WORK PACKAGE

UNIT MAINTENANCE
RECOVERY VEHICLE, FULL TRACKED: MEDIUM, M88A1
NSN 2350-00-122-6826, EIC AQA

**FUEL/WATER SEPARATOR AUTOMATIC DRAIN SYSTEM AND SOLENOID VALVE REPLACEMENT
REMOVAL, INSTALLATION**

INITIAL SETUP:

Tools and Special Tools

Tool kit, general mechanic's (item 59, WP 0490 00)
Suitable container

References

WP 0128 00
WP 0130 00

Materials/Parts

Lockwashers (4) (item 622, WP 0491 00)
Screws (6) (item 149, WP 0491 00)
Screws (4) (item 793, WP 0491 00)
Washers, flat (4) (item 842, WP 0491 00)

Equipment Condition

Powerplant removed (see WP 0098 00)

WARNING

Do not smoke or use open flame when working on fuel system: explosion may occur, causing severe injury or death.

Removal

1. Open drain cock and bleeder valve on fuel/water separator (see WP 0128 00) and drain fuel into suitable container.
2. Disconnect two wiring harness connectors (1 and 2) from control module (3).
3. Disconnect water level probes (4) and clamp (see WP 0128 00).
4. Remove control module (3) with two attached water level probes (4) by removing four screws (5), four flat washers (6), and clamp (7).

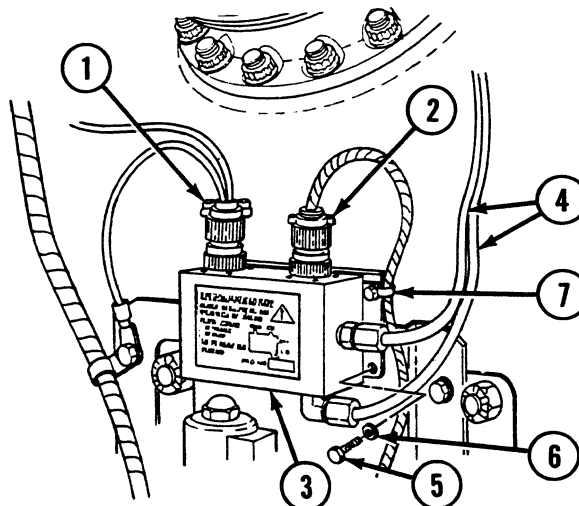

5. Disconnect fuel/water separator filter drain hose (8) from solenoid valve (9).
6. Disconnect wiring harness connector (1) from solenoid valve (9).
7. Disconnect solenoid valve drain tube (10) from solenoid valve (9).
8. Remove two assembled washer screws (11) and remove solenoid valve (9) from mounting bracket (12).
9. Remove mounting bracket (12) by removing four screws (13), four lockwashers (14), ground (15), and clamp (16).
10. Remove nipple (17) from solenoid valve (9) IN opening and elbow (18) from solenoid valve OUT opening.

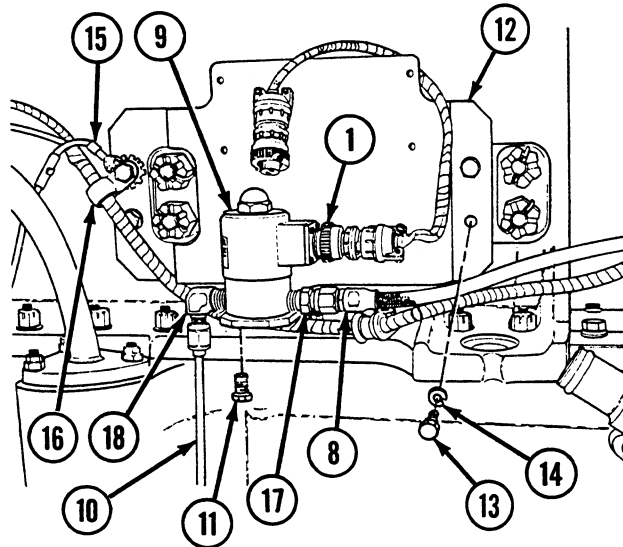

Installation

1. Install mounting bracket (12), ground (15), and clamp (16) with four screws (13) and four lockwashers (14).
2. Install control module (3) and clamp (7) with four screws (5) and four flat washers (6).
3. Connect water level probes (4) and clamp (see WP 0128 00).
4. Connect two wiring harness connectors (1 and 2) to control module (3).

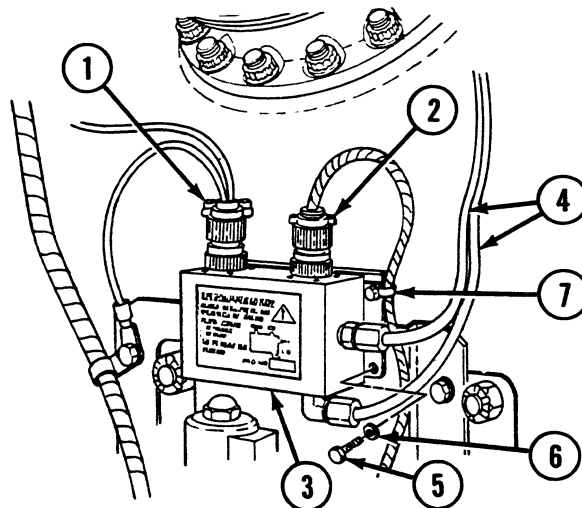

5. Install nipple (17) in solenoid valve (9) IN opening and elbow (18) in solenoid valve OUT opening.
6. Install solenoid valve (9) on mounting bracket (12) and secure with two assembled washer screws (11).

7. Install solenoid valve drain tube (10), wiring harness connector (1), and fuel/water separator filter drain hose (8) to solenoid valve (9).
8. Close drain cock on fuel/water separator (see WP 0130 00). Activate electric fuel pump until fuel flows from bleeder valve (see WP 0130 00). Tighten bleeder valve.

NOTE

Follow-on maintenance: Install powerplant (see WP 0098 00).

END OF WORK PACKAGE

UNIT MAINTENANCE
RECOVERY VEHICLE, FULL TRACKED: MEDIUM, M88A1
NSN 2350-00-122-6826, EIC AQA

**MANIFOLD HEATER FUEL SUPPLY SOLENOID VALVE AND FUEL FILTER REPLACEMENT
REMOVAL, INSTALLATION**

INITIAL SETUP:**Tools and Special Tools**

Tool kit general mechanic's (item 59, WP 0490 00)

Materials/Parts

Bolts, assembled washer (2) (item 148, WP 0491 00)

Lockwashers (2) (item 621, WP 0491 00)

Lockwashers (2) (item 637, WP 0491 00)

Nuts, self-locking (2) (item 492, WP 0491 00)

Screws (2) (item 370, WP 0491 00)

Materials/Parts (cont.)

Screws (2) (item 603, WP 0491 00)

Washers (2) (item 309, WP 0491 00)

Washers, flat (4) (item 357, WP 0491 00)

Equipment Condition

Air inlet grilles removed (see WP 0342 00)

MASTER switch turned to OFF position

WARNING

Ignition units on this engine are capable of producing extremely high voltage. The output is sufficient to cause a dangerous electrical shock. Never touch uncovered or live connections. Ensure MASTER switch is in OFF position prior to removal or maintenance.

WARNING

Do not smoke or use open flame when working on fuel system: explosion may occur, causing severe injury or death.

Removal

1. Disconnect two manifold heater fuel tubes (1) from fuel outlet tee (2).
2. Disconnect fuel filter inlet tube (3) from fuel filter (4).
3. Disconnect electrical harness plug (5).
4. Remove manifold heater fuel supply solenoid valve (6) with fuel filter (4) and bracket (7) as an assembly by removing two nuts (8) and two flat washers (9).

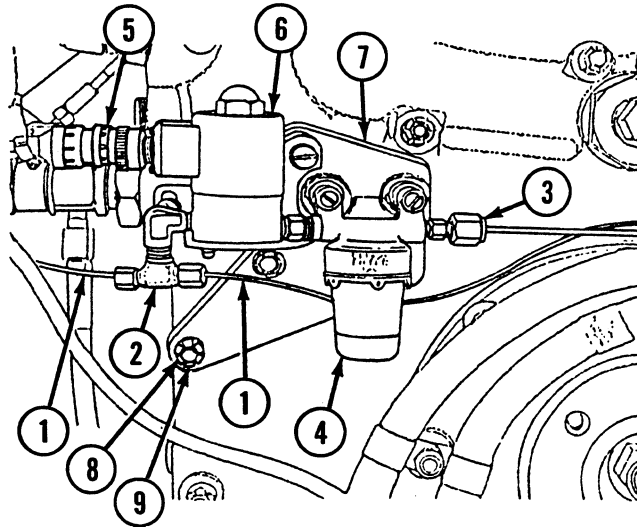

5. Remove manifold heater fuel supply solenoid valve (6) with fuel filter (4) from bracket (7) by removing four slotted-head screws (10), four lockwashers (11), and two flat washers (12).
6. Remove nipple (13) from fuel filter (4), then remove fuel outlet tee (2) and elbow (14) from manifold heater fuel supply solenoid valve (6).
7. Separate manifold heater fuel supply solenoid valve (6) from fuel filter (4) by removing nipple (15).
8. Remove manifold heater fuel supply solenoid valve (6) from bracket (16) by removing two screws (17) and two lockwashers (18).

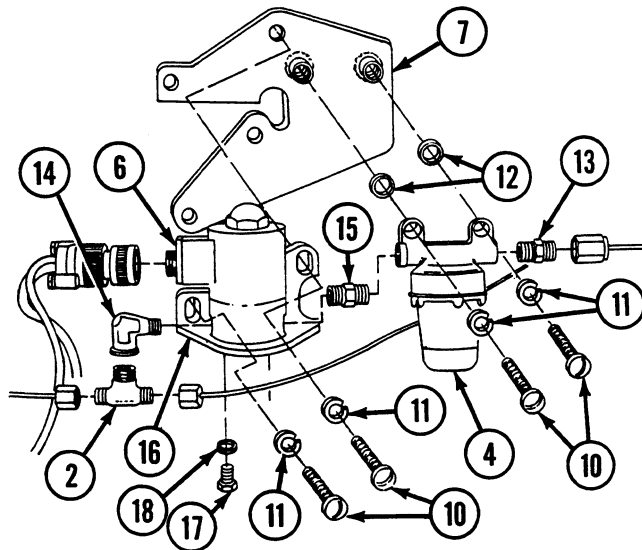

Installation

1. Install manifold heater fuel supply solenoid valve (6) to bracket (16) with two screws (17) and two lockwashers (18).
2. Install manifold heater fuel supply solenoid valve (6) to fuel filter (4) with nipple (15).
3. Install nipple (13) to fuel filter (4), then install fuel outlet tee (2) and elbow (14) to manifold heater fuel supply solenoid valve (6).
4. Install four slotted-head screws (10), four lockwashers (11), and two flat washers (12) to bracket (7).
5. Install manifold heater fuel supply solenoid valve (6) with fuel filter (4) and bracket (7) as an assembly with two nuts (8) and two flat washers (9).
6. Connect electrical harness plug (5) and fuel filter inlet tube (3) to fuel filter (4).
7. Connect two manifold heater fuel tubes (1) to fuel outlet tee (2).

NOTE

Follow-on maintenance: Turn MASTER switch to ON position; Install air inlet grille (see WP 0342 00).

END OF WORK PACKAGE

UNIT MAINTENANCE
RECOVERY VEHICLE, FULL TRACKED: MEDIUM, M88A1
NSN 2350-00-122-6826, EIC AQA

MANIFOLD HEATER IGNITION UNIT REPLACEMENT
REMOVAL, INSTALLATION

INITIAL SETUP:**Tools and Special Tools**

Tool kit, general mechanic's (item 59, WP 0490 00)

Equipment Condition

Powerplant removed (see WP 0098 00)

Materials/Parts

Nuts, self-locking (2) (item 491, WP 0491 00)

Screws (2) (item 815, WP 0491 00)

WARNING

Ignition units on this engine are capable of producing extremely high voltage. The output is sufficient to cause a dangerous electrical shock. Never touch uncovered or live connections. Ensure MASTER switch is in OFF position prior to removal or maintenance.

WARNING

Do not smoke or use open flame when working on fuel system: explosion may occur, causing severe injury or death.

NOTE

Removal and installation procedures are the same for the ignition unit on each side of the engine.

Removal

1. Disconnect two electrical wiring harness connectors (1) from manifold heater ignition unit (2).
2. Remove two screws (3) and two self-locking nuts (4). Remove two clamps (5) and manifold heater ignition unit (2).

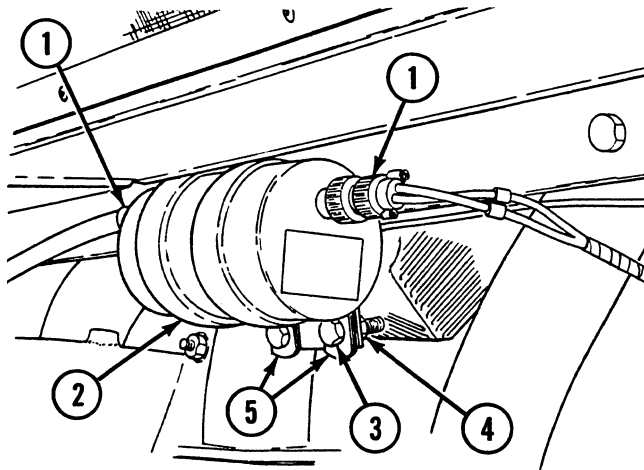
**Installation**

1. Install manifold heater ignition unit (2) into two clamps (5) and secure with two screws (3) and two self-locking nuts (4).
2. Connect two electrical wiring harness connectors (1) on manifold heater ignition unit (2).

NOTE

Follow-on maintenance: Install powerplant (see WP 0098 00).

END OF WORK PACKAGE

UNIT MAINTENANCE
RECOVERY VEHICLE, FULL TRACKED: MEDIUM, M88A1
NSN 2350-00-122-6826, EIC AQA
MANIFOLD HEATER FUEL RETURN SOLENOID VALVE REPLACEMENT
REMOVAL, INSTALLATION

INITIAL SETUP:**Tools and Special Tools**

Tool kit, general mechanic's (item 59, WP 0490 00)

Equipment Condition

Engine deck removed (see WP 0336 00)
MASTER switch turned to OFF position

Materials/Parts

Bolts, assembled washer (2) (item 148, WP 0491 00)
Screws (2) (item 132, WP 0491 00)
Washers, flat (2) (item 357, WP 0491 00)

WARNING

Ignition units on this engine are capable of producing extremely high voltage. The output is sufficient to cause a dangerous electrical shock. Never touch uncovered or live connections. Ensure MASTER switch is in OFF position prior to removal or maintenance.

WARNING

Do not smoke or use open flame when working on fuel system: explosion may occur, causing severe injury or death.

Removal

1. Disconnect electrical harness connector (1).
2. Disconnect fuel solenoid outlet tube (2) and two fuel solenoid inlet tubes (3) from solenoid valve (4).
3. Remove solenoid valve (4) with related fittings from mounting bracket (5) by removing two assembled washer bolts (6) and two flat washers (7).
4. Remove mounting bracket (5) by removing three assembled washer bolts (8).

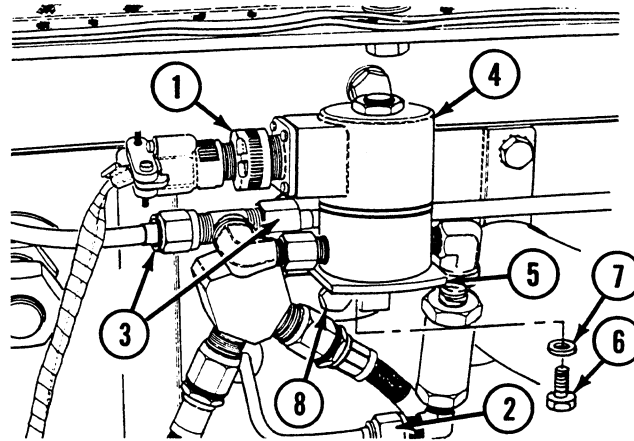

5. Remove fuel solenoid inlet coupling (9), elbow (10), and tee (11) from solenoid valve (4).
6. Remove outlet elbow (12), fuel return check valve (13), and elbow (14) from solenoid valve (4).

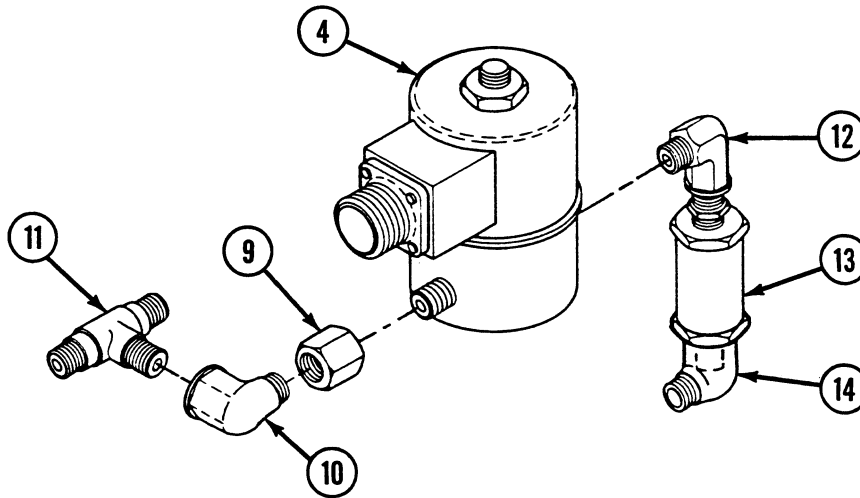

Installation**NOTE**

If fuel return check valve (13) is removed, it must be installed with arrow pointing down.

1. Install outlet elbow (12), fuel return check valve (13), and elbow (14) on solenoid valve (4).
2. Install tee (11), elbow (10), and fuel solenoid inlet coupling (9) on solenoid valve (4).
3. Install mounting bracket (5) with three assembled washer bolts (8).
4. Install solenoid valve (4) with related fittings on mounting bracket (5) with two flat washers (7) and two assembled washer bolts (6).
5. Connect fuel solenoid outlet tube (2) and two fuel solenoid inlet tubes (3).
6. Connect electrical wiring harness connector (1).

NOTE

Follow-on maintenance: Turn MASTER switch to ON position; Install engine deck (see WP 0336 00).

END OF WORK PACKAGE

UNIT MAINTENANCE
RECOVERY VEHICLE, FULL TRACKED: MEDIUM, M88A1
NSN 2350-00-122-6826, EIC AQA
MANIFOLD HEATER NOZZLE ASSEMBLY MAINTENANCE
REMOVAL, DISASSEMBLY, ASSEMBLY, INSTALLATION

INITIAL SETUP:**Tools and Special Tools**

Tool kit, general mechanic's (item 59, WP 0490 00)

Materials/Parts

Bushing (item 422, WP 0491 00)
 Gaskets (2) (item 310, WP 0491 00)

Materials/Parts (cont.)

Nuts, self-locking (8) (item 491, WP 0491 00)
 Screw (item 558, WP 0491 00)
 Spark plugs (with gasket) (2) (item 429, WP 0491 00)
 Washers, flat (8) (item 305, WP 0491 00)

WARNING

Do not smoke or use open flame when working on fuel system: explosion may occur, causing severe injury or death.

NOTE

Removal and installation procedures are the same for both the left and right bank. Right bank shown.

Removal

1. Disconnect electrical lead (1) from spark plug (with gasket) (2).
2. Disconnect fuel inlet hose (3) from fuel inlet elbow (4). Remove fuel inlet elbow and bushing (5).
3. Disconnect fuel return tube (6) from fuel return elbow (7). Remove fuel return elbow.
4. Remove manifold heater (8) and gasket (9) by removing four self-locking nuts (10) and four flat washers (11). Discard gasket.

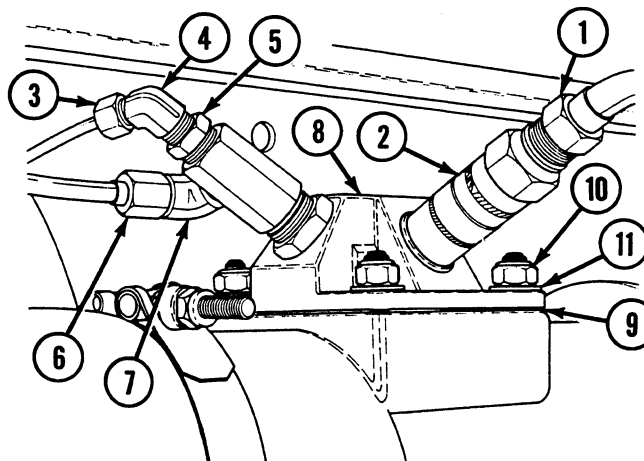

Disassembly

1. Remove spark plug (with gasket) (2) from manifold heater (8).
2. Loosen locknut (12) and remove manifold heater nozzle assembly (13).
3. Remove screw (14) and baffle (15).

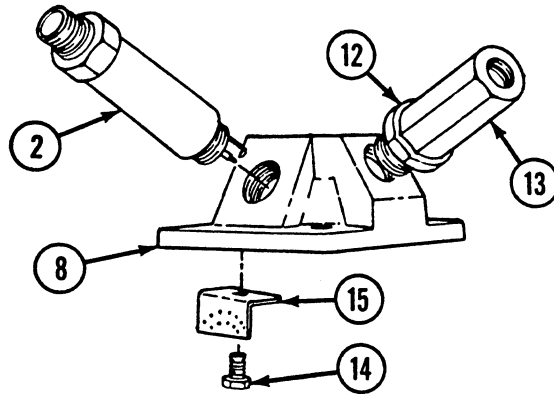

Assembly

1. Install screw (14) and baffle (15) to manifold heater (8).
2. Install manifold heater nozzle assembly (13) and tighten locknut (12).
3. Inspect spark plug (with gasket) (2), electrodes, and insulator condition. Replace spark plug (with gasket) if unserviceable.
4. Set spark plug (with gasket) (2) gap at 0.094–0.114 in. (2.39–2.90 mm).
5. Install spark plug (with gasket) (2).

Installation

1. Install manifold heater (8) and gasket (9) with four self-locking nuts (10) and four flat washers (11).
2. Connect fuel return elbow (7) and fuel return tube (6) to manifold heater nozzle assembly (13).
3. Connect bushing (5), fuel inlet elbow (4), and fuel inlet hose (3) to manifold heater nozzle assembly (13).
4. Connect electrical lead (1) to spark plug (with gasket) (2).

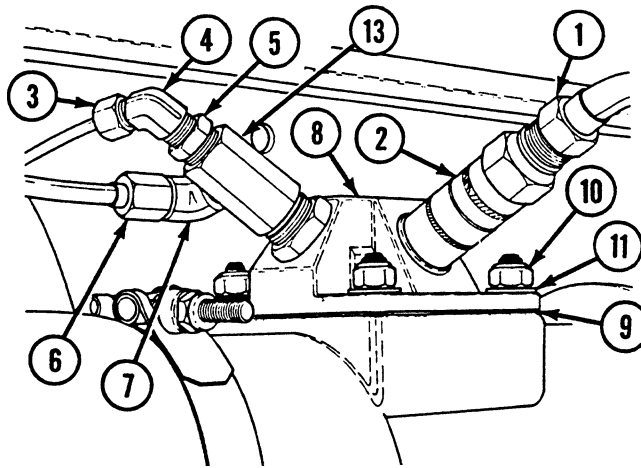

END OF WORK PACKAGE

UNIT MAINTENANCE
RECOVERY VEHICLE, FULL TRACKED: MEDIUM, M88A1
NSN 2350-00-122-6826, EIC AQA
MANIFOLD HEATER OPERATION CHECK

INITIAL SETUP:**Tools and Special Tools**

Tool kit, general mechanic's (item 59, WP 0490 00)

Equipment Condition

Powerplant removed (see WP 0098 00)

References

WP 0099 00
WP 0336 00
TM 9-2350-256-10

WARNING

Do not smoke or use open flame when working on fuel system: explosion may occur, causing severe injury or death.

Servicing

1. After maintenance has been performed on either the intake manifold heater or on the manifold heater fuel system, operation of the heater should be checked before installing the powerplant. To check manifold heater operation perform steps 2 thru 6.
2. Prepare the powerplant for operation outside the vehicle (see WP 0099 00).
3. The main fuel line shutoff solenoid should be closed and the engine cranked to obtain an air supply to the manifold heaters.
4. Operate purge pump and simultaneously press heater button in pump handle.
5. If heater is operative, heat will be felt at intake manifold turbosupercharger tube.
6. If there is no heat, first check manifold heater accessory on which maintenance was performed. Check wiring harness and heater spark plug lead for faulty connections. Check installation of spark plug, nozzle, and fuel line fittings, and check operation of heater fuel supply and return solenoids.

NOTE

Manifold heater operation can be checked with the powerplant in the vehicle by removing the engine deck (see WP 0336 00) and placing a hand on the intake manifold downstream from the heater.

NOTE

Follow-on maintenance: Install powerplant (see WP 0098 00).

END OF WORK PACKAGE

UNIT MAINTENANCE
RECOVERY VEHICLE, FULL TRACKED: MEDIUM, M88A1
NSN 2350-00-122-6826, EIC AQA
MANIFOLD HEATER FUEL LINES AND FITTINGS REPLACEMENT
REMOVAL, INSTALLATION

INITIAL SETUP:**Tools and Special Tools**

Tool kit, general mechanic's (item 59, WP 0490 00)

Equipment Condition

Powerplant removed (see WP 0098 00)

Materials/Parts

Nut, self-locking (item 492, WP 0491 00)

Nuts, self-locking (10) (item 497, WP 0491 00)

Screws (14) (item 594, WP 0491 00)

WARNING

Do not smoke or use open flame when working on fuel system: explosion may occur, causing severe injury or death.

NOTE

Removal and installation procedures are the same for both the left and right banks. Right bank shown.

Removal

1. Remove tube assembly (1) by loosening union at each end of tube assembly.
2. Remove five clamps (2) by removing self-locking nut (3) and screw (4) from each.

NOTE

Left bank does not have self-locking nut (5) and clamp (6).

3. Remove self-locking nut (5) and clamp (6).
4. Remove tube assembly (7) by loosening union at each end of tube assembly.
5. Remove elbow (8) and bushing (9) from nozzle assembly (10).
6. Remove two clamps (11) by removing two screws (12).
7. Remove tube assembly (13) by loosening union at each end of tube assembly.
8. Remove elbow (14) from nozzle assembly (10).

Installation

1. Install elbow (14) onto nozzle assembly (10).
2. Install tube assembly (13) by tightening union at each end of tube assembly.
3. Install two clamps (11) with two screws (12).
4. Install bushing (9) and elbow (8) onto nozzle assembly (10).
5. Install tube assembly (7) by tightening union at each end of tube assembly.
6. Install clamp (6) with self-locking nut (5).
7. Install five clamps (2) each with self-locking nut (3) and screw (4).
8. Install tube assembly (1) by tightening union at each end of tube assembly.

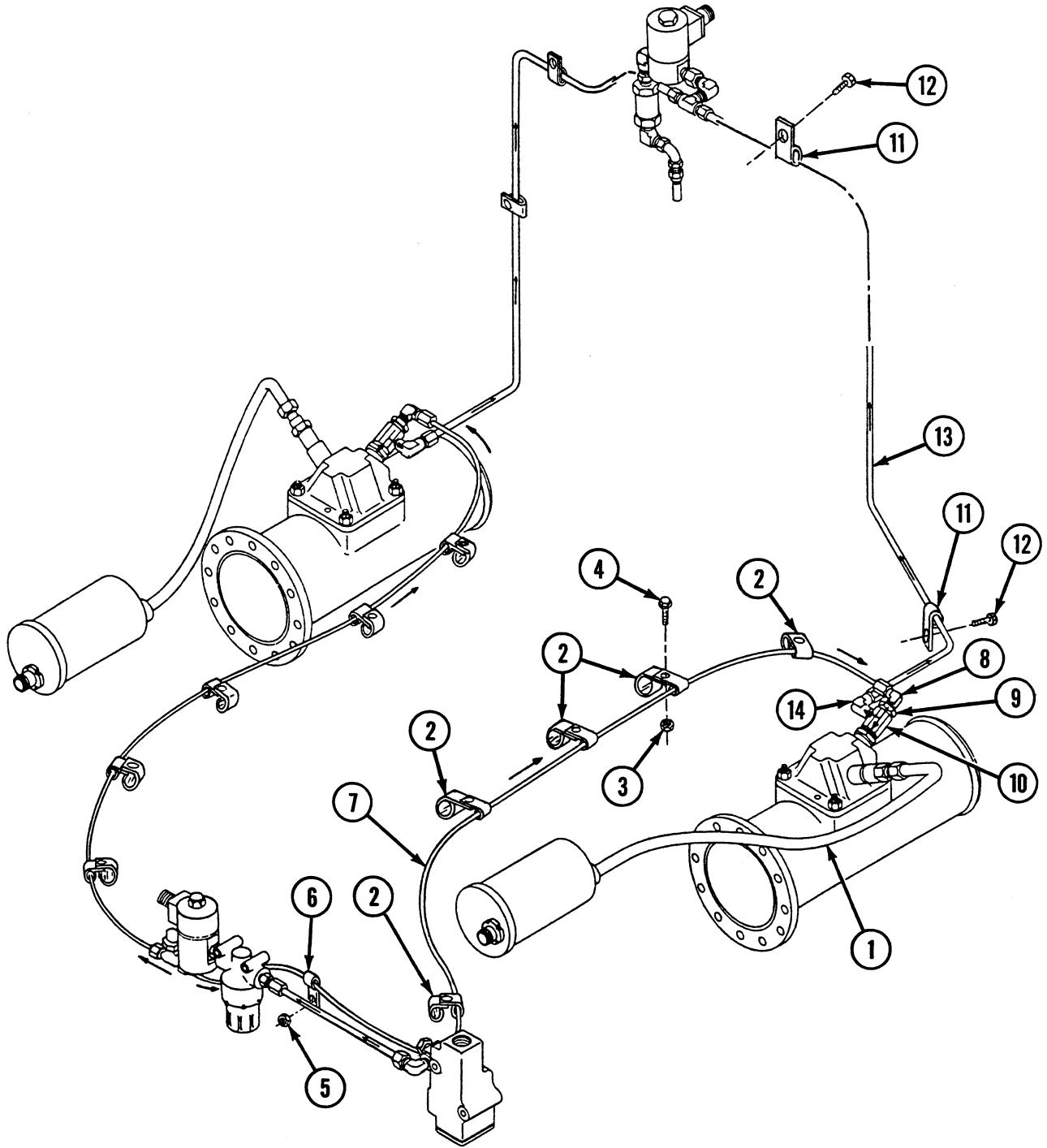

NOTE

Follow-on maintenance: Install powerplant (see WP 0098 00).

END OF WORK PACKAGE

UNIT MAINTENANCE
RECOVERY VEHICLE, FULL TRACKED: MEDIUM, M88A1
NSN 2350-00-122-6826, EIC AQA
AIR CLEANER MAINTENANCE
REMOVAL, DISASSEMBLY, SERVICE, ASSEMBLY, INSTALLATION

INITIAL SETUP:**Tools and Special Tools**

Tool kit, general mechanic's (item 59, WP 0490 00)

Materials/Parts

Adhesive, rubber-base (item 3, WP 0489 00)
 Bearings (2) (item 289, WP 0491 00)
 Clamp (item 343, WP 0491 00)
 Lockwashers (3) (item 638, WP 0491 00)
 Lockwashers (4) (item 640, WP 0491 00)
 Lockwashers (3) (item 642, WP 0491 00)
 Nuts (3) (item 761, WP 0491 00)
 Packing, preformed (item 556, WP 0491 00)
 Screw (item 150, WP 0491 00)
 Screws (3) (item 371, WP 0491 00)
 Screws (8) (item 372, WP 0491 00)
 Screws (4) (item 391, WP 0491 00)
 Seals (2) (item 50, WP 0491 00)

Materials/Parts (cont.)

Spring (item 294, WP 0491 00)
 Washer (item 79, WP 0491 00)
 Washer (item 81, WP 0491 00)
 Washers, flat (3) (item 362, WP 0491 00)
 Washers, flat (8) (item 534, WP 0491 00)
 Washers, flat (4) (item 537, WP 0491 00)
 Washers, flat (3) (item 539, WP 0491 00)
 Washers, flat (4) (item 540, WP 0491 00)
 Washers, flat (4) (item 546, WP 0491 00)
 Wingbolt (item 80, WP 0491 00)
 Wingbolt (item 846, WP 0491 00)
 Wingnuts (4) (item 658, WP 0491 00)

References

TM 9-2350-256-10

NOTE

Removal and installation procedures are the same for both the left- and right-side air cleaners.

NOTE

In illustration personnel heater, fire extinguishers, and air purifier shown removed for clarity only.

Removal

1. Loosen four wingnuts (1) and remove air cleaner cover assembly (2).

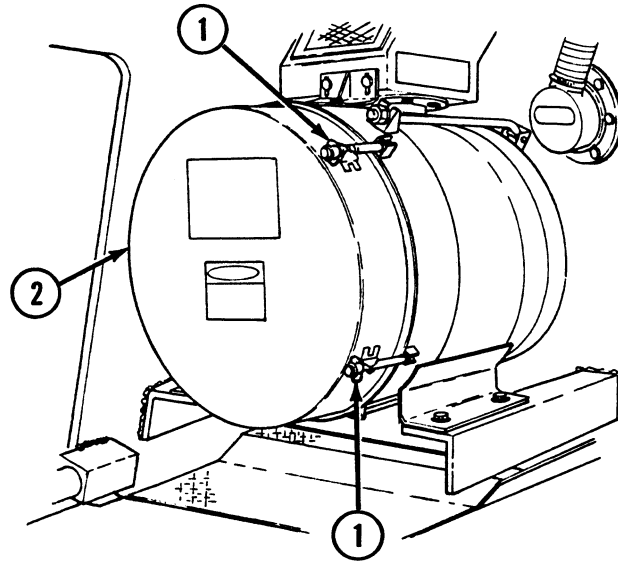

2. Remove wingbolt (3), washer (4), and filter element (5).

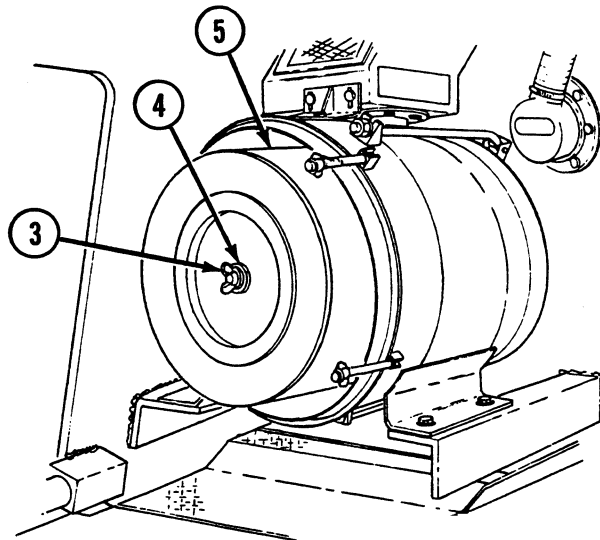

3. Remove three screws (6), three lockwashers (7), three flat washers (8), and bracket (9).
4. Remove clamp (10) from air inlet opening (11).
5. Remove three nuts (12), three lockwashers (13), and three flat washers (14) from three retaining bolts (15).
6. Remove four screws (16), four lockwashers (17), eight flat washers (18), air cleaner housing (19), and six spacer plates (20).

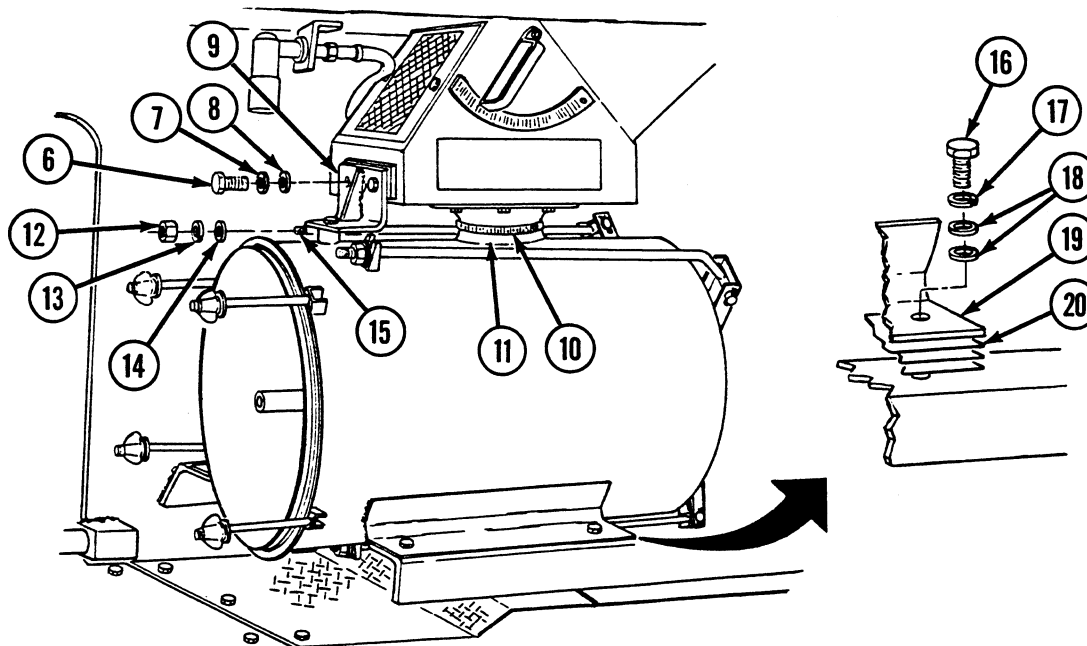

7. Remove six screws (21), six flat washers (22), collar (23), and flange (24).
8. Remove two screws (25), two flat washers (26), and guard (27).
9. Remove screw (28), handle (29), spring (30), two bearings (31), damper (32), and two seals (33).

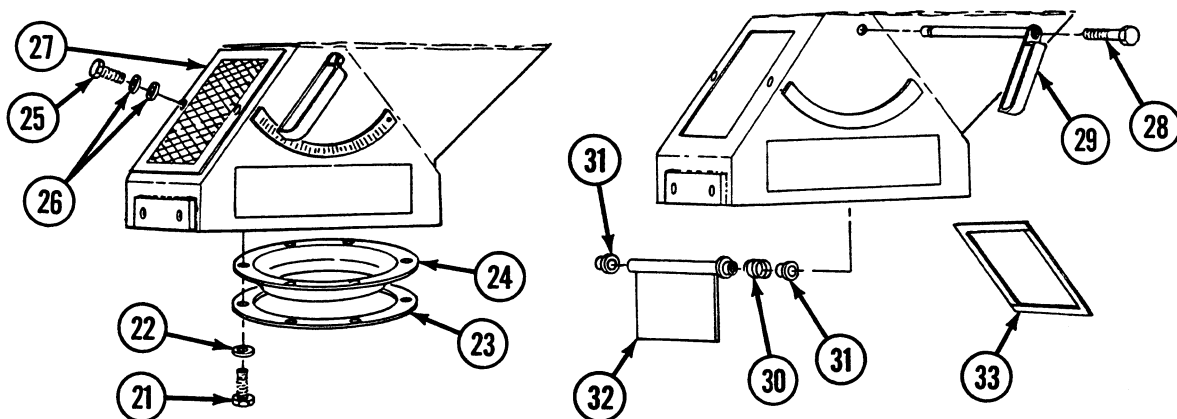

Disassembly

1. Remove four wingnuts (1), four flat washers (34), and air cleaner cover assembly (2).
2. Remove wingbolt (3), washer (4), and filter element (5).
3. Remove wingbolt (35), washer (36), and baffle (37) from air cleaner cover (38).
4. Remove preformed packing (39) if necessary.

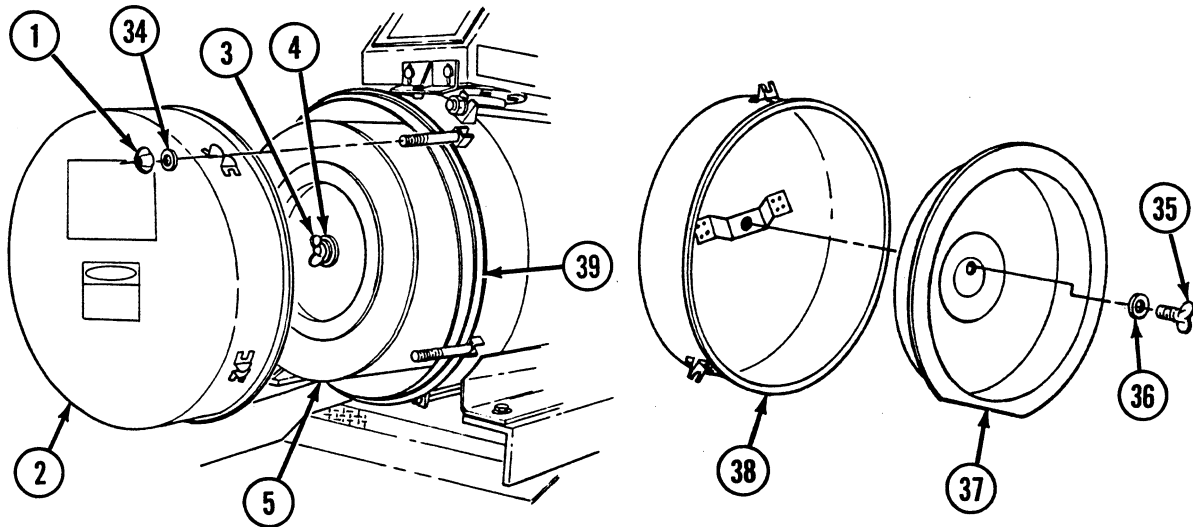

Servicing

1. Refer to TM 9-2350-256-10 for service instructions for air cleaners.

Assembly

1. Install preformed packing (39) if removed.
2. Install baffle (37), washer (36), and wingbolt (35) in air cleaner cover (38).
3. Install filter element (5), washer (4), and wingbolt (3).
4. Install air cleaner cover assembly (2) with four flat washers (34) and four wingnuts (1).

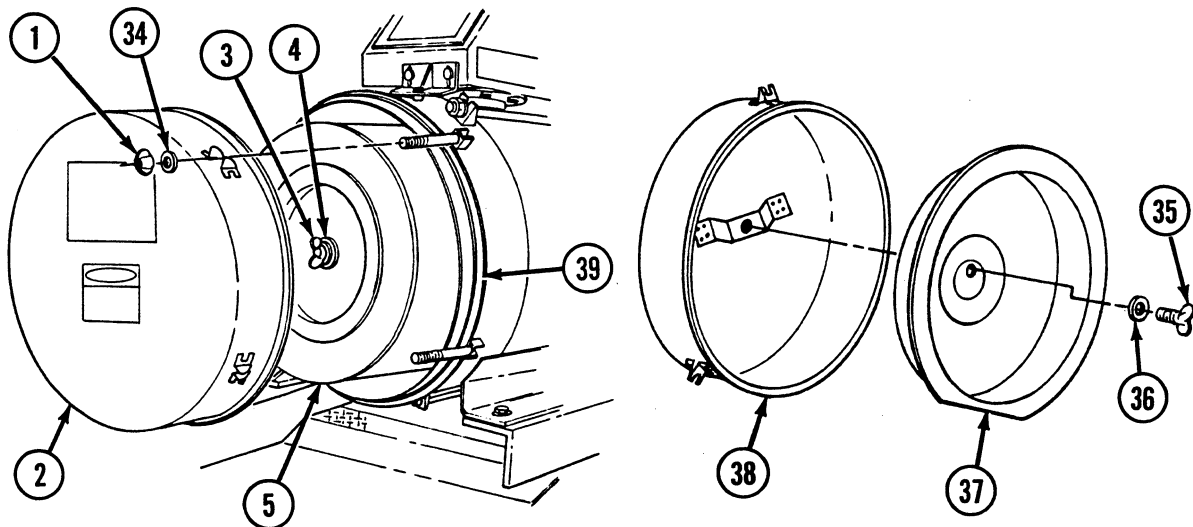

Installation

1. Install two seals (33) with adhesive.
2. Install damper (32), two bearings (31), spring (30), handle (29), and screw (28).
3. Install guard (27) with two flat washers (26) and two screws (25).
4. Install flange (24) and collar (23) with six flat washers (22) and six screws (21).

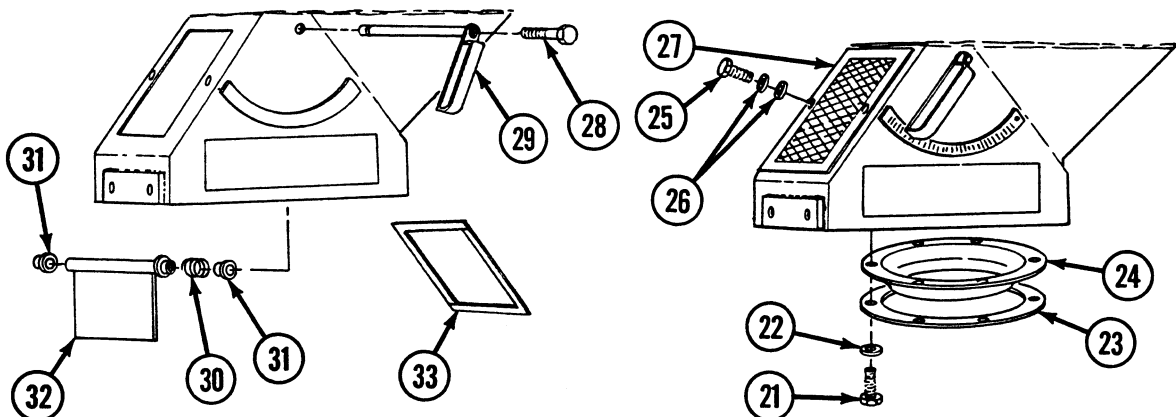

5. Install air cleaner housing (19), six spacer plates (20), eight flat washers (18), four lockwashers (17), and four screws (16).
6. Install three retaining bolts (15) with three flat washers (14), three lockwashers (13), and three nuts (12).
7. Install clamp (10) to air inlet opening (11).
8. Install bracket (9) with three flat washers (8), three lockwashers (7), and three screws (6).

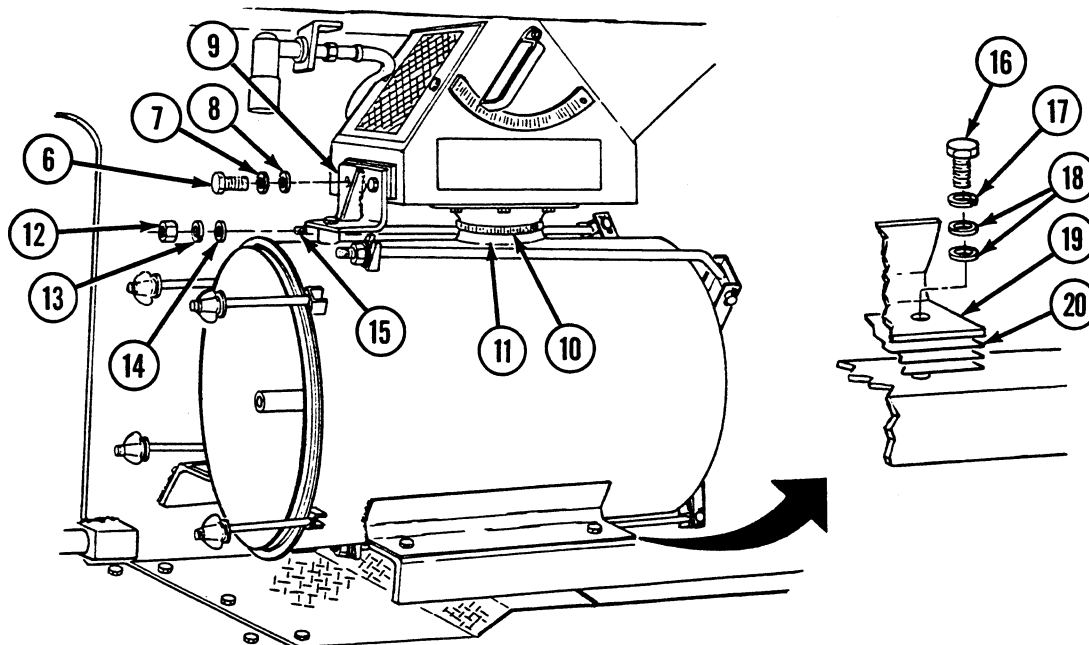

9. Install filter element (5) with washer (4) and wingbolt (3).
10. Install air cleaner cover assembly (2) by tightening four wingnuts (1).

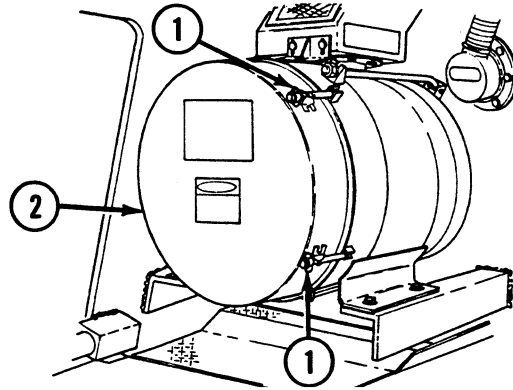
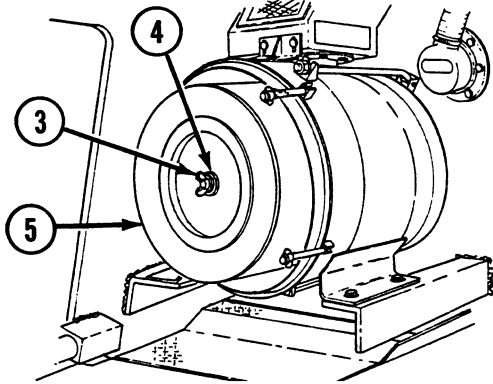

END OF WORK PACKAGE

UNIT MAINTENANCE
RECOVERY VEHICLE, FULL TRACKED: MEDIUM, M88A1
NSN 2350-00-122-6826, EIC AQA
AIR CLEANER RESTRICTION GAGE ASSEMBLY REPLACEMENT
REMOVAL, INSTALLATION

INITIAL SETUP:**Tools and Special Tools**

Tool kit, general mechanic's (item 59, WP 0490 00)

Materials/Parts

Lockwashers (4) (item 638, WP 0491 00)

Nuts (4) (item 767, WP 0491 00)

WARNING

Removal and installation procedures are the same for both the left- and right-side air cleaner restriction gages.

Removal

1. Remove hose (1) and adapter (2) from mounting bracket (3).
2. Remove two nuts (4), two lockwashers (5), and air cleaner restriction gage (6).
3. Remove hose (1), adapter (7), and elbow (8) from air intake elbow assembly (9).

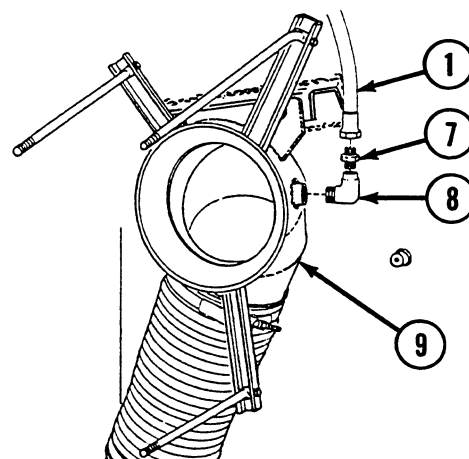
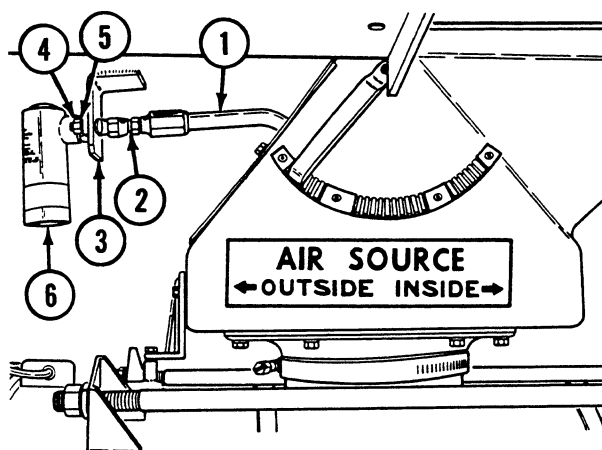
**Installation**

1. Install elbow (8), adapter (7), and hose (1) to air intake elbow assembly (9).
2. Install air cleaner restriction gage (6), two lockwashers (5), and two nuts (4).
3. Install adapter (2) and hose (1) at mounting bracket (3).

END OF WORK PACKAGE

UNIT MAINTENANCE
RECOVERY VEHICLE, FULL TRACKED: MEDIUM, M88A1
NSN 2350-00-122-6826, EIC AQA

AIR INTAKE HOSES REPLACEMENT
REMOVAL, INSTALLATION

INITIAL SETUP:**Tools and Special Tools**

Tool kit, general mechanic's (item 59, WP 0490 00)

Materials/Parts

Clamps (12) (item 78, WP 0491 00)
Lockwashers (6) (item 640, WP 0491 00)
Lockwashers (2) (item 642, WP 0491 00)
Nuts (2) (item 769, WP 0491 00)
Packing, preformed (item 15, WP 0491 00)
Pins, cotter (3) (item 347, WP 0491 00)
Screws (2) (item 401, WP 0491 00)
Screw (item 721, WP 0491 00)

Materials/Parts (cont.)

Screw (item 800, WP 0491 00)
Screws (2) (item 804, WP 0491 00)
Washers, flat (3) (item 538, WP 0491 00)

Equipment Condition

Air cleaner removed (see WP 0137 00)
Engine deck removed (see WP 0336 00)
APU access cover removed (see WP 0334 00)
Left- and center-front air inlet grilles removed (see WP 0342 00)
Air inlet doors opened (see WP 0341 00)

Removal**NOTE**

Steps 1 thru 5 apply to both sides.

1. Remove three retaining rods (1) by removing cotter pin (2) and straight pin (3) from each.
2. Remove two clamps (4) and air intake hose (5).
3. Remove two screws (6), two lockwashers (7), two flat washers (8), and two nuts (9) from right and left side of elbow assembly (10).
4. Disconnect air cleaner restriction indicator hose (11) from air intake hose (5).
5. Remove preformed packing (12).

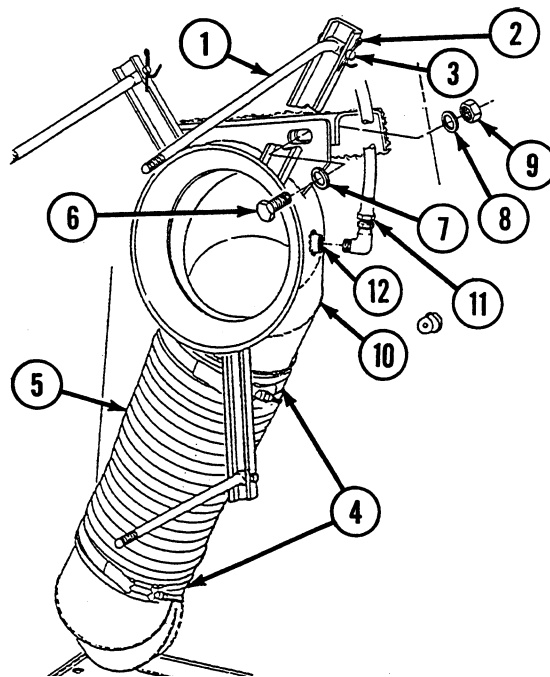

NOTE

Steps 6 thru 9 apply only to left side

6. Loosen two clamps (13) and remove air intake hose (14).

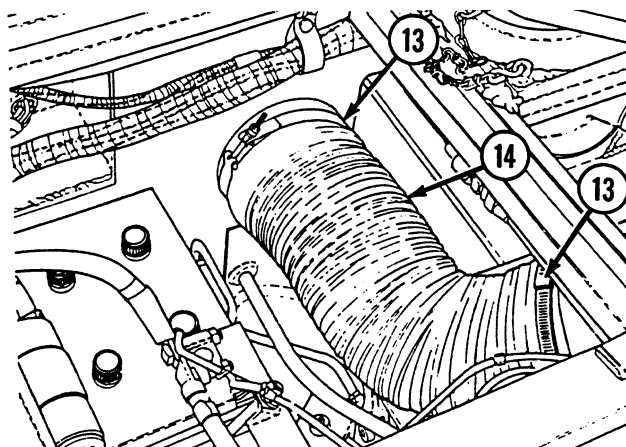

7. Remove two clamps (15) and air hose (16).
8. Remove two clamps (17), air hose (18), and air duct (19).
9. Remove two screws (20), two lockwashers (21), and tube assembly (22).

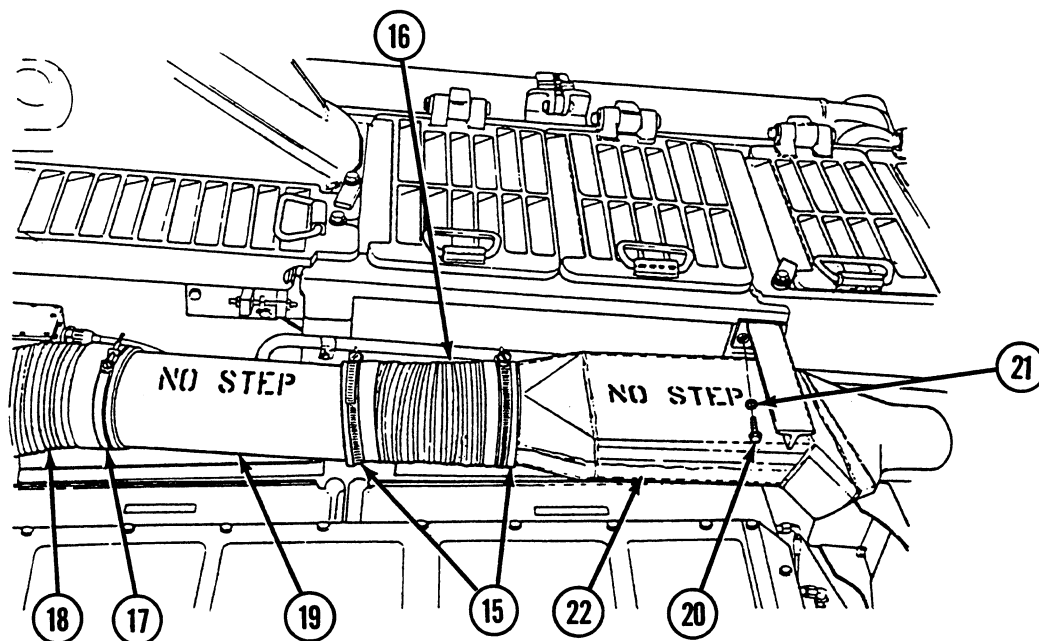

NOTE

Steps 10 thru 13 apply only to right side.

10. Remove four clamps (23) and two air intake hoses (24).
11. Remove two screws (25), two lockwashers (26), two flat washers (27), clip (28), and air duct (29).

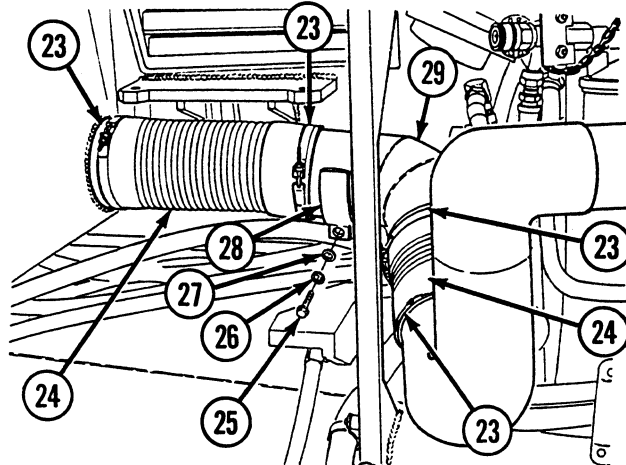

12. Remove two clamps (30) and air hose (31).
13. Remove two screws (32), two lockwashers (33), clamp (34), spacer (35), and tube assembly (36).

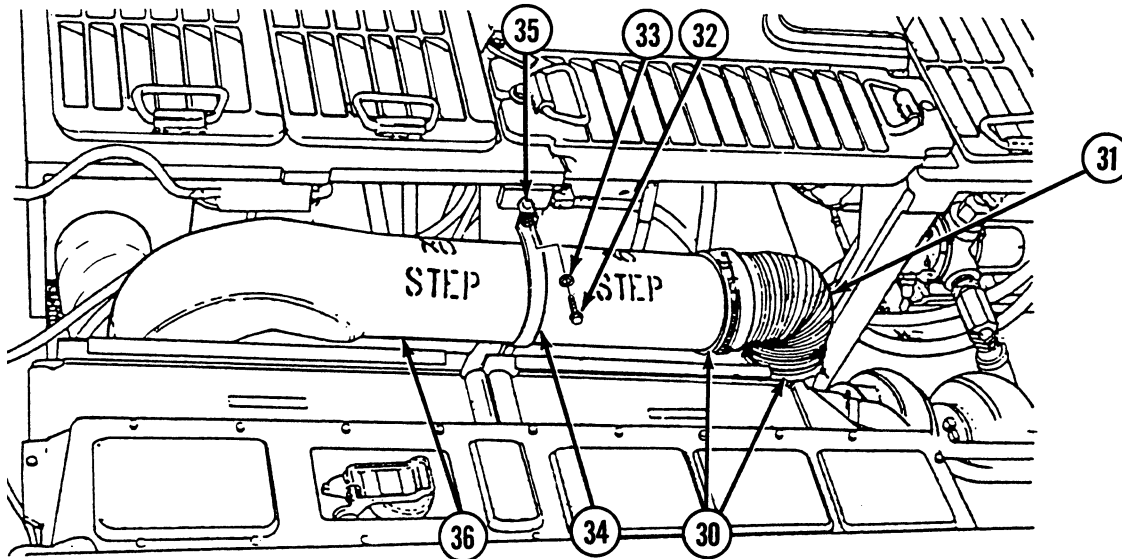

Installation**NOTE**

Steps 1 thru 4 apply only to right side.

1. Install tube assembly (36), spacer (35), clamp (34), two lockwashers (33), and two screws (32).
2. Install air hose (31) and two clamps (30).
3. Install air duct (29), clip (28), two flat washers (27), two lockwashers (26), and two screws (25).
4. Install two air intake hoses (24) and four clamps (23).

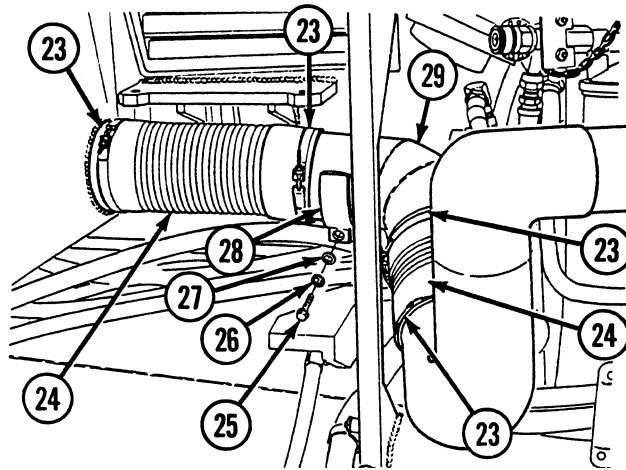

NOTE

Steps 5 thru 8 apply only to left side.

5. Install tube assembly (22) with two lockwashers (21) and two screws (20).
6. Install air hose (18) and two clamps (17).
7. Install air duct (19), air hose (16), and clamps (15).

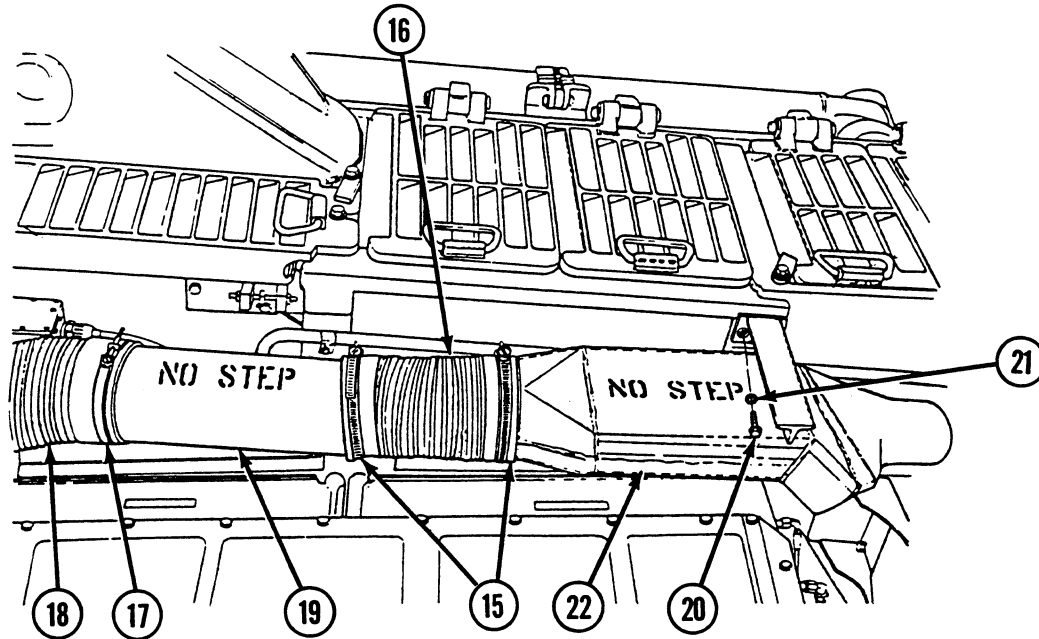

8. Install air intake hose (14) and tighten clamps (13).

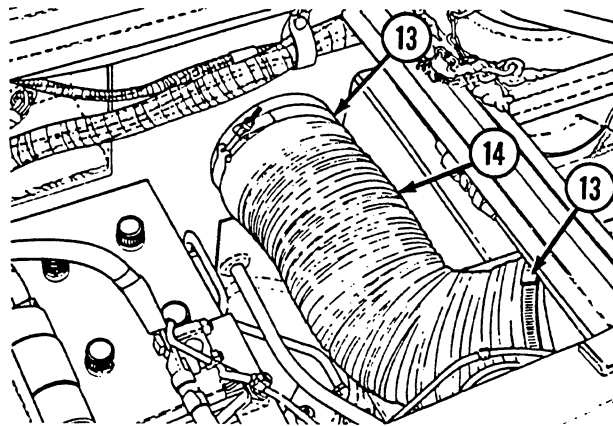

NOTE

Steps 9 thru 12 apply to both sides.

9. Install air intake hose (5) and two clamps (4).
10. Install preformed packing (12) and connect air cleaner restriction indicator hose (11).
11. Install right and left side of elbow assembly (10) with two nuts (9), two flat washers (8), two lockwashers (7), and two screws (6).
12. Install three retaining rods (1), three cotter pins (2), and three straight pins (3).

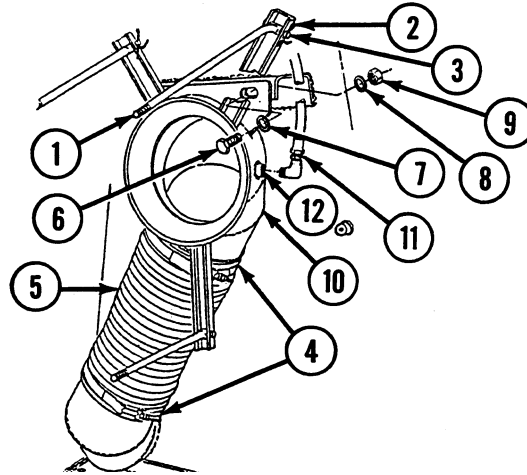
**NOTE**

Follow-on maintenance: Close air inlet doors (see WP 0341 00); Install left- and center-front air inlet grilles (see WP 0342 00); Install APU access cover (see WP 0334 00); Install engine deck (see WP 0336 00); Install air cleaner (see WP 0137 00).

END OF WORK PACKAGE

UNIT MAINTENANCE
RECOVERY VEHICLE, FULL TRACKED: MEDIUM, M88A1
NSN 2350-00-122-6826, EIC AQA

ENGINE AIR INLET SEAL REPLACEMENT
REMOVAL, INSTALLATION

INITIAL SETUP:**Tools and Special Tools**

Tool kit, general mechanic's (item 59, WP 0490 00)

Materials/Parts

Gaskets (2) (item 332, WP 0491 00)

Lockwashers (16) (item 639, WP 0491 00)

Materials/Parts (cont.)

Nuts (16) (item 768, WP 0491 00)

Washers, flat (16) (item 535, WP 0491 00)

Equipment Condition

Engine deck removed (see WP 0336 00)

NOTE

Removal and installation procedures are the same for both the left- and right-side air inlet elbows.

Removal

1. Remove air inlet elbow (1) by removing eight nuts (2), eight lockwashers (3), and eight flat washers (4) from studs.
2. Remove insulation sleeving (5).

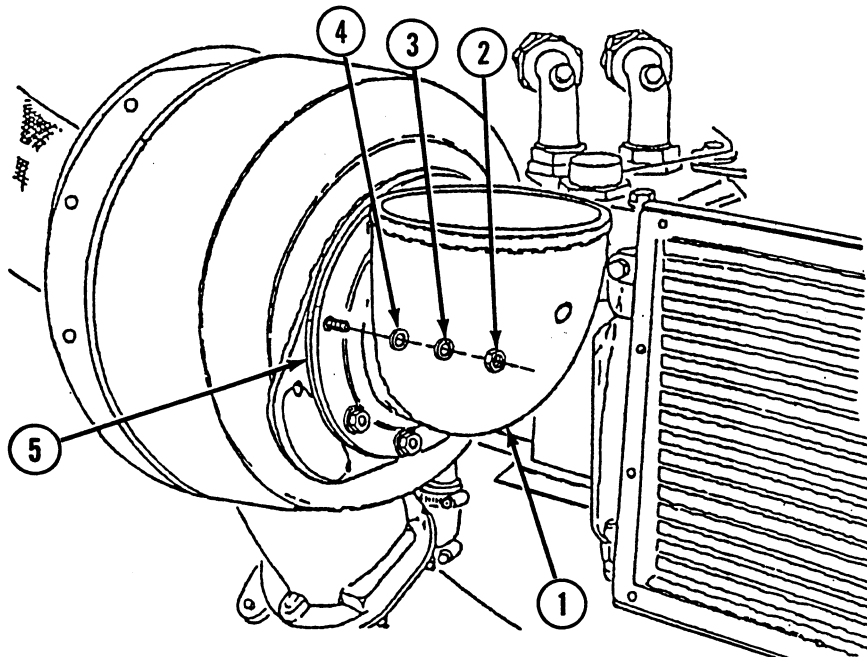

Installation

1. Install insulation sleeving (5).
2. Install air inlet elbow (1) by installing eight flat washers (4), eight lockwashers (3), and eight nuts (2) on studs.

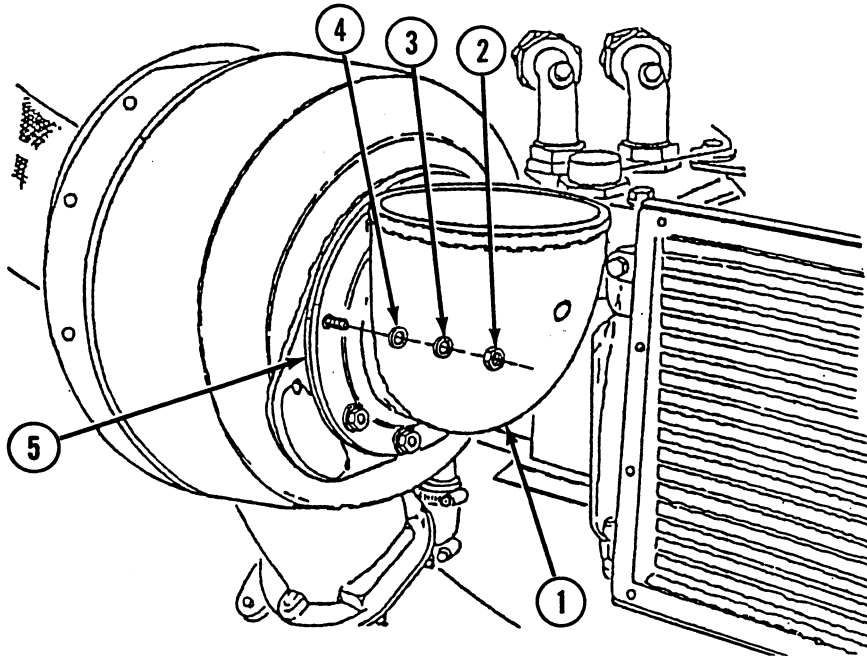
**NOTE**

Follow-on maintenance: Install engine deck (see WP 0336 00).

END OF WORK PACKAGE

UNIT MAINTENANCE
RECOVERY VEHICLE, FULL TRACKED: MEDIUM, M88A1
NSN 2350-00-122-6826, EIC AQA

**EXHAUST PIPES REPLACEMENT
REMOVAL, INSTALLATION**

INITIAL SETUP:**Tools and Special Tools**

Tool kit, general mechanic's (item 59, WP 0490 00)

Materials/Parts

Gaskets (2) (item 117, WP 0491 00)
Lockwashers (34) (item 629, WP 0491 00)
Nuts (34) (item 670, WP 0491 00)
Nuts, self-locking (12) (item 852, WP 0491 00)

Materials/Parts (cont.)

Packings (2) (item 94, WP 0491 00)
Screws (34) (item 747, WP 0491 00)
Washers, flat (68) (item 444, WP 0491 00)

References

WP 0336 00

NOTE

Removal and installation procedures are the same for both exhaust pipes.

Removal

1. Remove cap (1) by removing clamp (2).
2. Remove engine deck (see WP 0336 00).
3. Remove packing (3) from engine exhaust pipe (4).

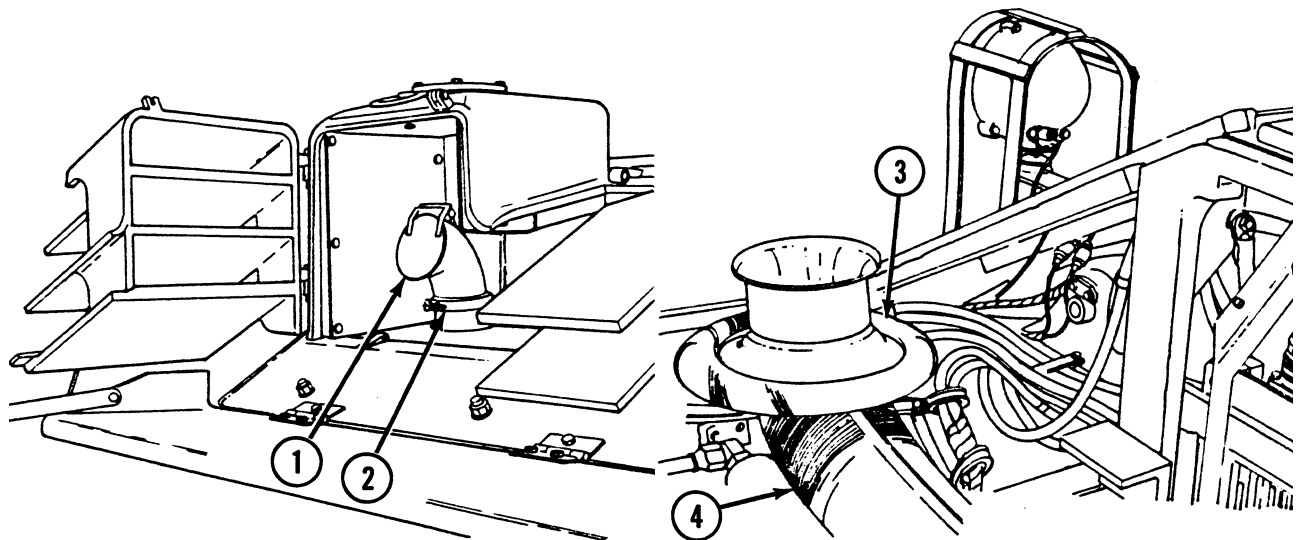

4. Remove engine exhaust pipe (4) with covers (5 and 6) by removing six self-locking nuts (7).
5. Remove gasket (8).
6. Remove covers (5 and 6) by removing 17 screws (9), 34 flat washers (10), 17 lockwashers (11), and 17 nuts (12).

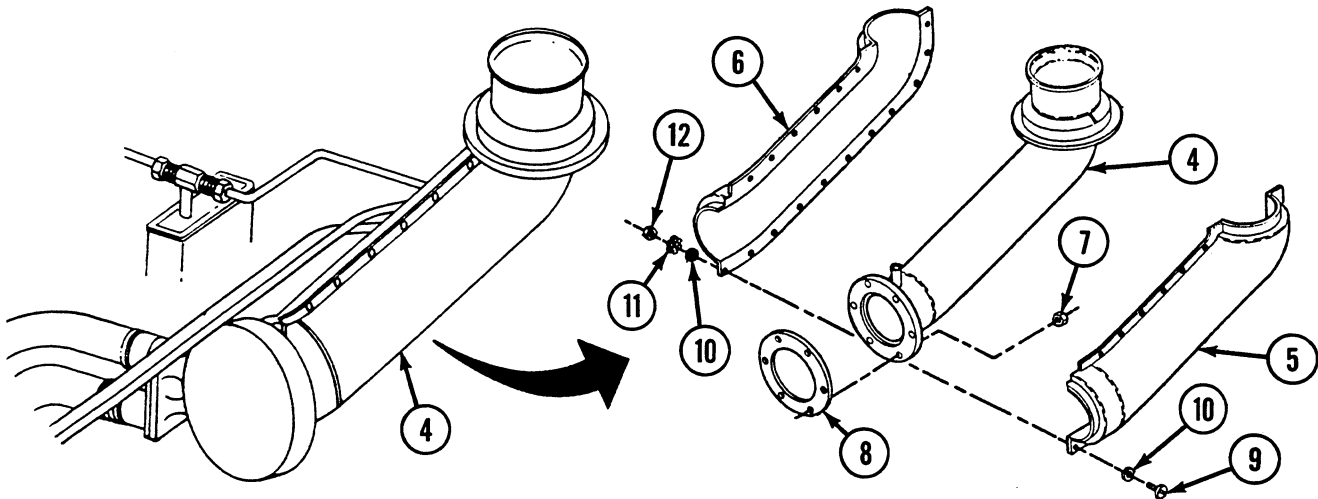

Installation

1. Install two covers (5 and 6) by installing 17 nuts (12), 17 lockwashers (11), 34 flat washers (10), and 17 screws (9).
2. Install gasket (8).
3. Install engine exhaust pipe (4) by installing six self-locking nuts (7).
4. Install packing (3) on engine exhaust pipe (4).
5. Install engine deck (see WP 0336 00).
6. Install cap (1) by installing clamp (2).

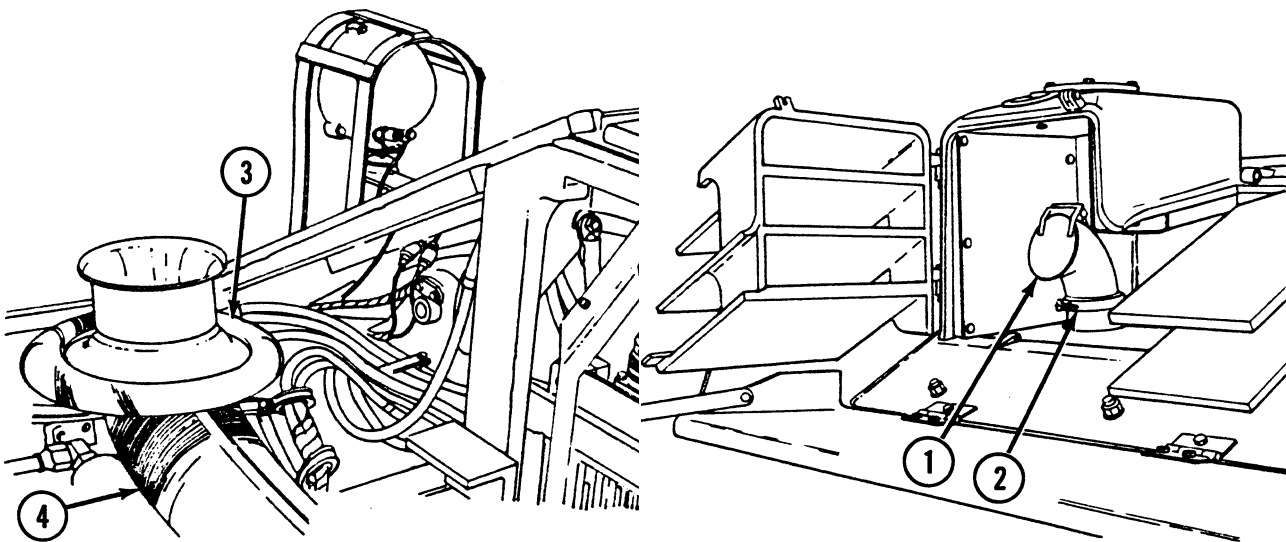

END OF WORK PACKAGE

UNIT MAINTENANCE
RECOVERY VEHICLE, FULL TRACKED: MEDIUM, M88A1
NSN 2350-00-122-6826, EIC AQA
EXHAUST MANIFOLD CLAMPS REPLACEMENT
REMOVAL, INSTALLATION

INITIAL SETUP:**Tools and Special Tools**

Tool kit, general mechanic's (item 59, WP 0490 00)

Equipment Condition

Engine deck removed (see WP 0336 00)

Materials/Parts

Nuts, self-locking (4) (item 496, WP 0491 00)

Screws (4) (item 404, WP 0491 00)

Removal

1. Left Side: Remove two restraining strap halves (1) by removing screw (2) and self-locking nut (3).
2. Right Side: Remove two restraining strap halves (4) by removing screw (5) and self-locking nut (6).

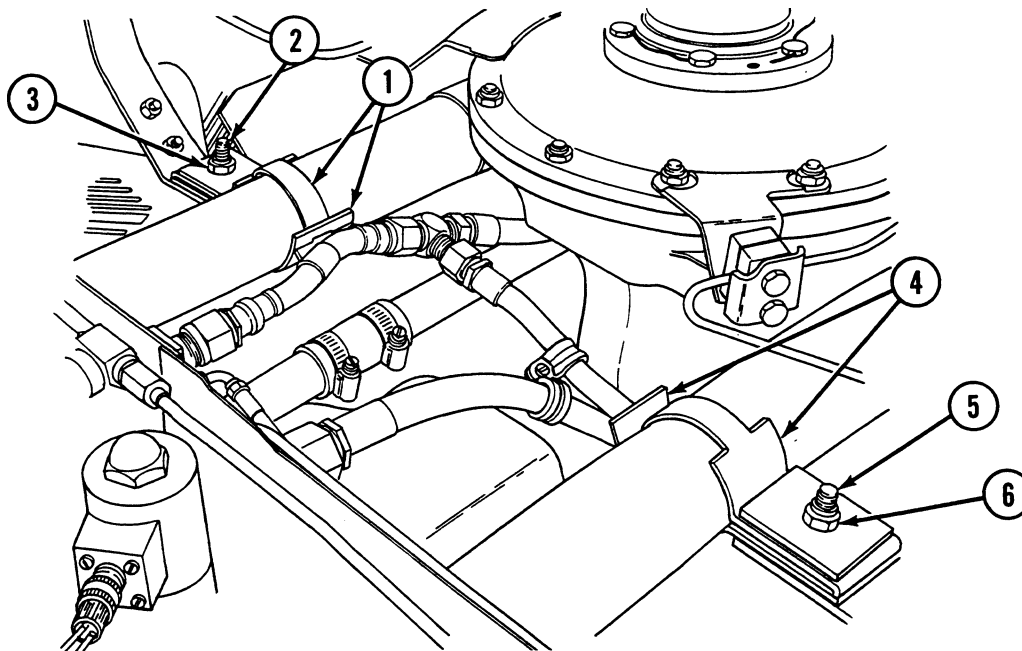
**Installation**

1. Right Side: Install two restraining strap halves (4) with screw (5) and self-locking nut (6).
2. Left Side: Install two restraining strap halves (1) with screw (2) and self-locking nut (3).

NOTE

Follow-on maintenance: Install engine deck (see WP 0336 00).

END OF WORK PACKAGE

CHAPTER 6
UNIT MAINTENANCE
MAINTENANCE INSTRUCTIONS
FOR
ENGINE COOLING SYSTEM
RECOVERY VEHICLE, FULL TRACKED: MEDIUM, M88A1
(NSN: 2350-00-122-6826)

CHAPTER 6
UNIT MAINTENANCE
MAINTENANCE INSTRUCTIONS

WORK PACKAGE INDEX

<u>Title</u>	<u>WP Sequence No.</u>
Engine Cooling Fan Shroud Seals Replacement Removal, Installation.....	0143 00
Engine Cooling Fans Replacement Removal, Installation.....	0144 00
Engine Cooling Fan Housings Maintenance Removal, Disassembly, Assembly, Installation.....	0145 00
Engine Cooling Fan Shroud and Related Parts Replacement Removal, Installation.....	0146 00
Engine Cooling Fan Vertical Shaft Oil Seals Maintenance Removal, Disassembly, Assembly, Installation.....	0147 00
Engine Oil Coolers and Screens Maintenance Removal, Inspection, Cleaning, Installation.....	0148 00
Engine Oil Cooler Lines Maintenance Removal, Cleaning, Inspection, Installation.....	0149 00

UNIT MAINTENANCE
RECOVERY VEHICLE, FULL TRACKED: MEDIUM, M88A1
NSN 2350-00-122-6826, EIC AQA
ENGINE COOLING FAN SHROUD SEALS REPLACEMENT
REMOVAL, INSTALLATION

INITIAL SETUP:**Tools and Special Tools**

Tool kit, general mechanic's (item 59, WP 0490 00)

Equipment Condition

Engine deck removed (see WP 0336 00)

Materials/Parts

Lockwashers (27) (item 640, WP 0491 00)

Screws (27) (item 721, WP 0491 00)

Washers, flat (27) (item 537, WP 0491 00)

Removal

1. Remove four corner seals (1) by removing four screws (2), four lockwashers (3), and four flat washers (4).
2. Remove two end seals (5) by removing seven screws (6), seven lockwashers (7), and seven flat washers (8).
3. Remove 2 side seals (9) by removing 16 screws (10), 16 lockwashers (11), and 16 flat washers (12).

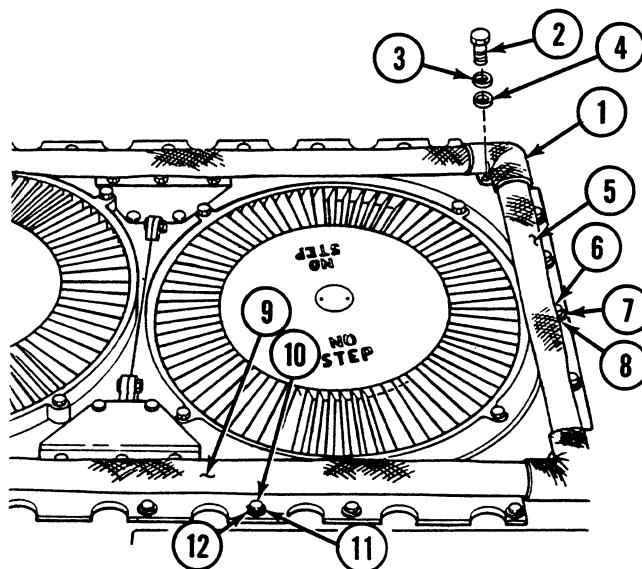
**Installation**

1. Install 2 side seals (9) by installing 16 flat washers (12), 16 lockwashers (11), and 16 screws (10).
2. Install two end seals (5) by installing seven flat washers (8), seven lockwashers (7), and seven screws (6).
3. Install four corner seals (1) by installing four flat washers (4), four lockwashers (3), and four screws (2).

NOTE

Follow-on maintenance: Install engine deck (see WP 0336 00).

END OF WORK PACKAGE

UNIT MAINTENANCE
RECOVERY VEHICLE, FULL TRACKED: MEDIUM, M88A1
NSN 2350-00-122-6826, EIC AQA
ENGINE COOLING FANS REPLACEMENT
REMOVAL, INSTALLATION

INITIAL SETUP:**Tools and Special Tools**

Tool kit, general mechanic's (item 59, WP 0490 00)
Wrench, torque, 0–175 lb-ft (0–237 N•m) (item 67, WP 0490 00)

Materials/Parts

Lockwashers (8) (item 135, WP 0491 00)
Nuts (2) (item 275, WP 0491 00)
Pins, cotter (2) (item 527, WP 0491 00)

Materials/Parts (cont.)

Screws (4) (item 354, WP 0491 00)
Screws (2) (item 403, WP 0491 00)
Screws (2) (item 407, WP 0491 00)
Washers, flat (2) (item 330, WP 0491 00)

Equipment Condition

Shroud seals removed (see WP 0143 00)

NOTE

Removal and installation procedures are the same for both the forward and rear cooling fans.

Removal

1. Remove housing (1) by removing four screws (2) and four lockwashers (3).

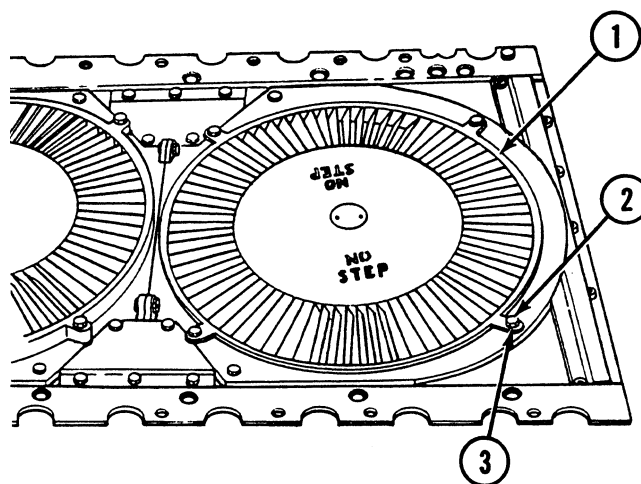

- Remove cotter pin (4), nut (5), and flat washer (6).

NOTE

Do not separate hub and fan, as this will affect the balance of the assembly.

NOTE

Both forward and rear hub and fan assemblies are interchangeable.

- Remove assembled fan (7) and hub (8).

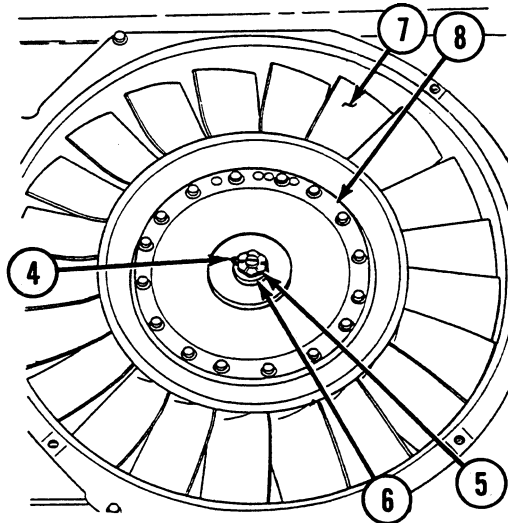

Installation

- Install assembled fan (7) and hub (8) on splined vehicle shaft.
- Install flat washer (6) and nut (5). Torque nut to 50 pound-feet (lb-ft) (68 newton-meters [N•m]).
- Align slot with hole in shaft and install cotter pin (4).

4. Check clearance between tip of each fan blade and rim of cooling fan housing (9) with feeler gage. If clearance is less than 0.062 inch (in.) (1.58 millimeters [mm]) at any point, loosen cooling fan housing mounting screws (10) and shift cooling fan housing to gain clearance.

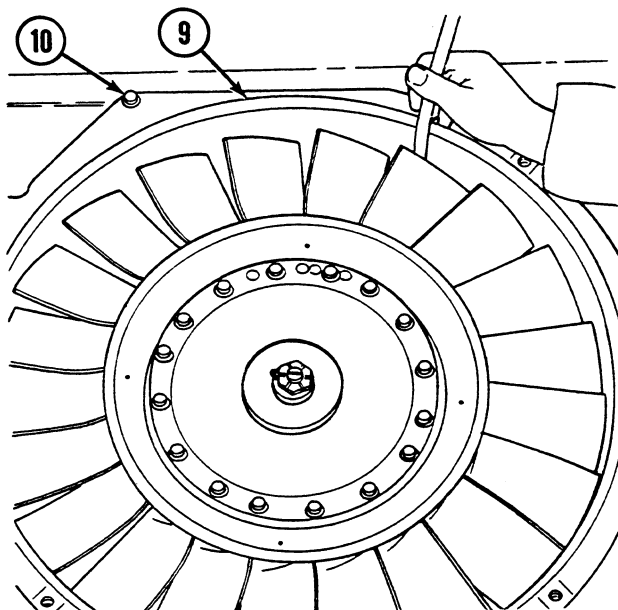

5. Using torque wrench, check release torque of cooling fan clutch. If clutch does not release at approximately 20 lb-ft (27 N•m), notify Direct Support Maintenance.
6. Position housing (1) on cooling fan housing (9) and install four screws (2) and four lockwashers (3).

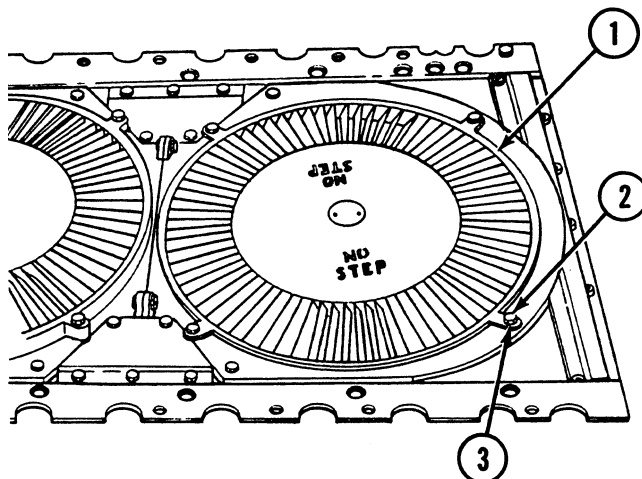

NOTE

Follow-on maintenance: Install shroud seals (see WP 0143 00).

END OF WORK PACKAGE

UNIT MAINTENANCE
RECOVERY VEHICLE, FULL TRACKED: MEDIUM, M88A1
NSN 2350-00-122-6826, EIC AQA

ENGINE COOLING FAN HOUSINGS MAINTENANCE
REMOVAL, DISASSEMBLY, ASSEMBLY, INSTALLATION

INITIAL SETUP:**Tools and Special Tools**

Tool kit, general mechanic's (item 59, WP 0490 00)

Materials/Parts

Inserts (8) (item 440, WP 0491 00)
 Inserts (8) (item 441, WP 0491 00)
 Lockwashers (4) (item 135, WP 0491 00)
 Nuts, self-locking (2) (item 492, WP 0491 00)

Materials/Parts (cont.)

Screws (10) (item 256, WP 0491 00)
 Screws (4) (item 403, WP 0491 00)
 Washers, flat (8) (item 309, WP 0491 00)

Equipment Condition

Cooling fans removed (see WP 0144 00)

Removal

1. Remove 2 access covers (1) by removing 10 screws (2).
2. Remove two screws (3), two flat washers (4), and two self-locking nuts (5).
3. Remove two cooling fan housings (6) by removing four screws (7), four lockwashers (8), and four flat washers (9).

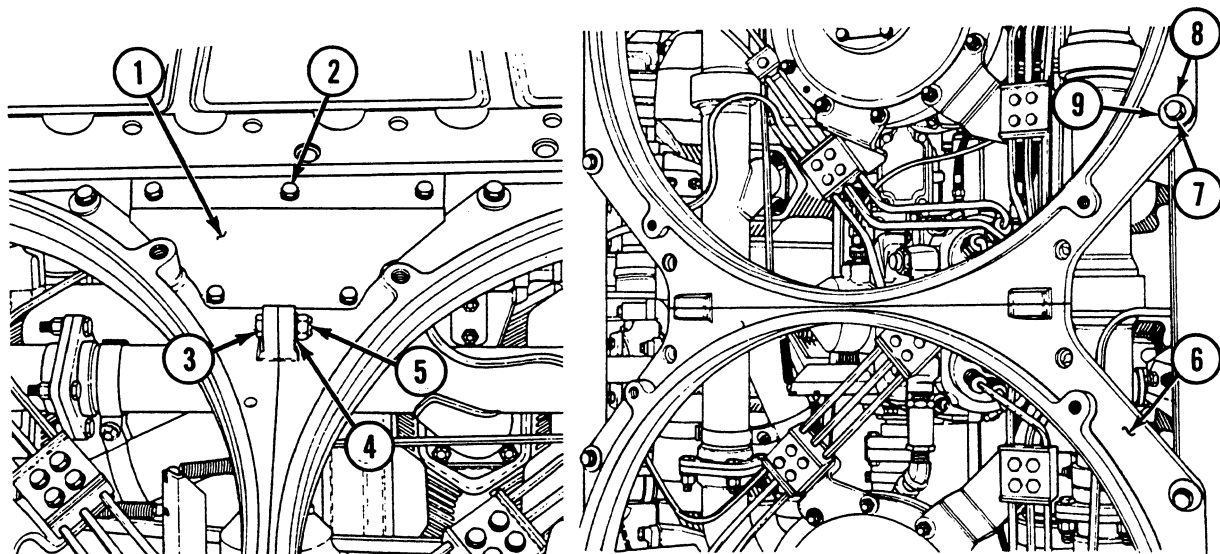

Disassembly

NOTE

Remove inserts only if loose or damaged.

1. Remove eight inserts (10) from two cooling fan housings (6).

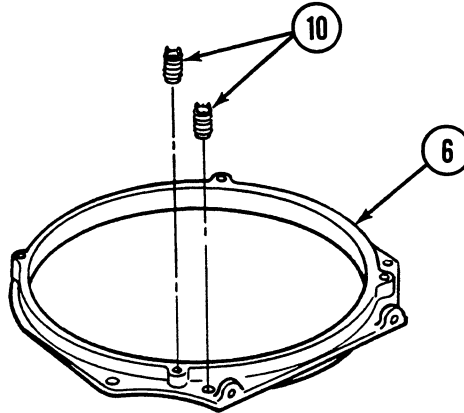

Assembly

1. Install eight inserts (10) in two cooling fan housings (6).

Installation

1. Install two cooling fan housings (6) by installing four flat washers (9), four lockwashers (8), and four screws (7).
2. Install two flat washers (4), two screws (3), and two self-locking nuts (5).
3. Install 2 access covers (1) by installing 10 screws (2).

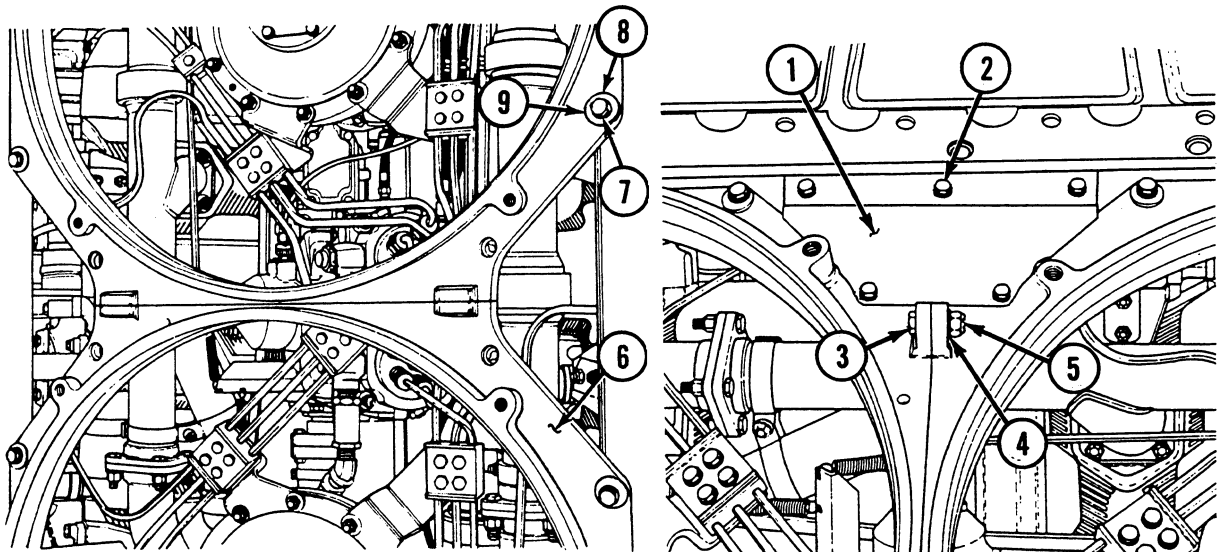

NOTE

Follow-on maintenance: Install cooling fans (see WP 0144 00).

END OF WORK PACKAGE

UNIT MAINTENANCE
RECOVERY VEHICLE, FULL TRACKED: MEDIUM, M88A1
NSN 2350-00-122-6826, EIC AQA
ENGINE COOLING FAN SHROUD AND RELATED PARTS REPLACEMENT
REMOVAL, INSTALLATION

INITIAL SETUP:**Tools and Special Tools**

Tool kit, general mechanic's (item 59, WP 0490 00)

Materials/Parts

Lockwashers (4) (item 135, WP 0491 00)

Lockwashers (4) (item 640, WP 0491 00)

Nuts (12) (item 491, WP 0491 00)

Materials/Parts (cont.)

Screws (4) (item 397, WP 0491 00)

Screws (12) (item 400, WP 0491 00)

Washers, flat (12) (item 535, WP 0491 00)

Equipment Condition

Cooling fan housings removed (see WP 0145 00)

Removal

1. Remove shroud mounting (1) by removing four screws (2) and four lockwashers (3).
2. Remove support assembly (4) by removing four screws (5) and four lockwashers (6).
3. Remove six self-locking nuts (7) and six flat washers (8) from each side of shroud (9).
4. Remove four screws (10) from end of shroud (9).
5. Remove two screws (11) from rear side of shroud (9).
6. Remove shroud (9) from engine.

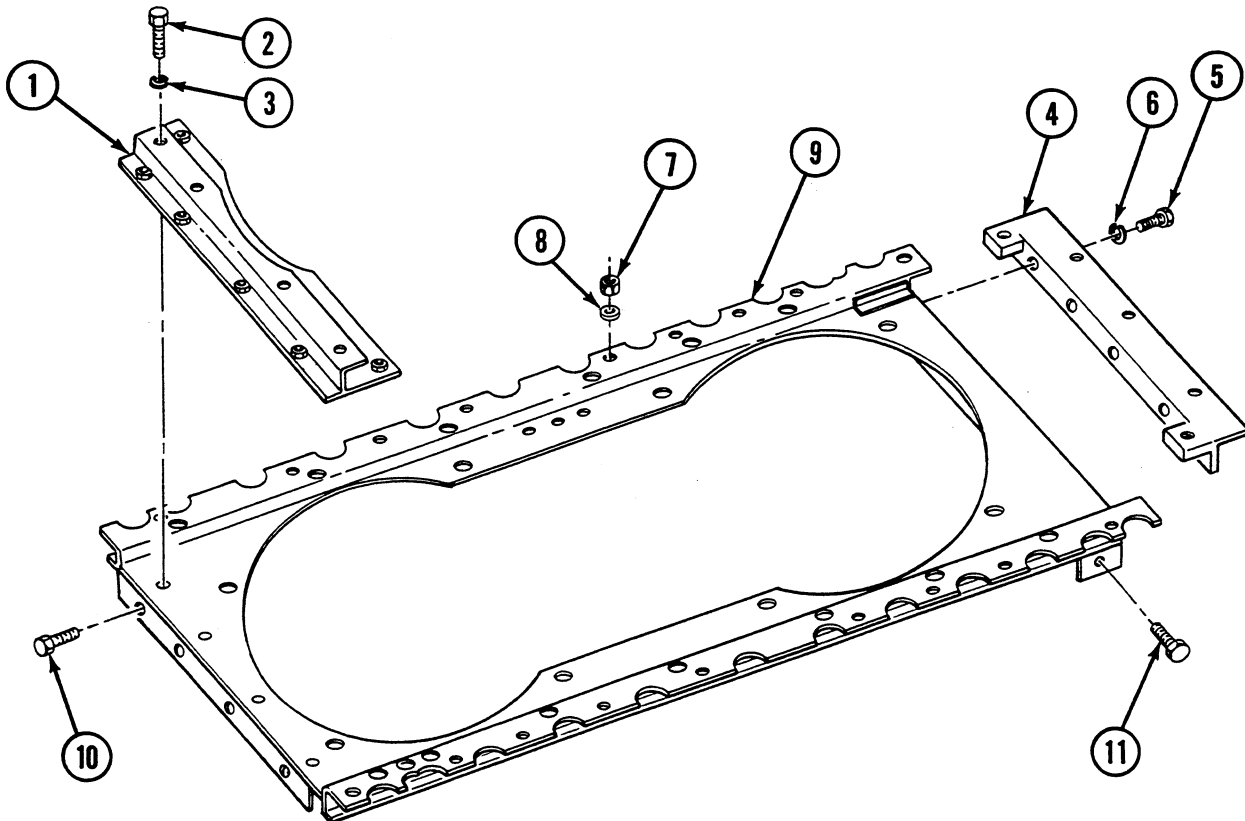

Installation

1. Install shroud (9) on engine with four screws (10) at end of shroud.
2. Install two screws (11) to rear side of shroud (9).
3. Install six self-locking nuts (7) and six flat washers (8) to each side of shroud (9).
4. Install support assembly (4) with four screws (5) and four lockwashers (6).
5. Install shroud mounting (1) with four screws (2) and four lockwashers (3).

NOTE

Follow-on maintenance: Install cooling fan housings (see WP 0145 00).

END OF WORK PACKAGE

UNIT MAINTENANCE
RECOVERY VEHICLE, FULL TRACKED: MEDIUM, M88A1
NSN 2350-00-122-6826, EIC AQA

ENGINE COOLING FAN VERTICAL SHAFT OIL SEALS MAINTENANCE
REMOVAL, DISASSEMBLY, ASSEMBLY, INSTALLATION

INITIAL SETUP:

Tools and Special Tools

Tool kit, general mechanic's (item 59, WP 0490 00)
 Screws, cap (jackscrews) (item 50, WP 0490 00)

Materials/Parts (cont.)

Seals, oil (2) (item 63, WP 0491 00)
 Washers, flat (12) (item 843, WP 0491 00)

Materials/Parts

Compound, sealing (item 29, WP 0489 00)
 Gaskets (2) (item 109, WP 0491 00)
 Lockwires (2) (item 484, WP 0491 00)
 Screws (12) (item 353, WP 0491 00)

References

TM 9-2350-256-10

Equipment Condition

Cooling fans removed (see WP 0144 00)

NOTE

Removal and installation are the same for both the front and rear cooling fan oil seals.

Removal

1. Cut and remove lockwire (1).
2. Remove six screws (2) and six flat washers (3) securing vertical drive shaft oil seal housing assembly (4) to fan drive housing cover (5).
3. Install two 5/16-18 by 4 in.- (101.6 mm-) long jackscrews (6) in screw holes provided in oil seal housing assembly (4).
4. Alternately tighten the two jackscrews (6) until oil seal housing assembly (4) separates from fan drive housing cover (5).

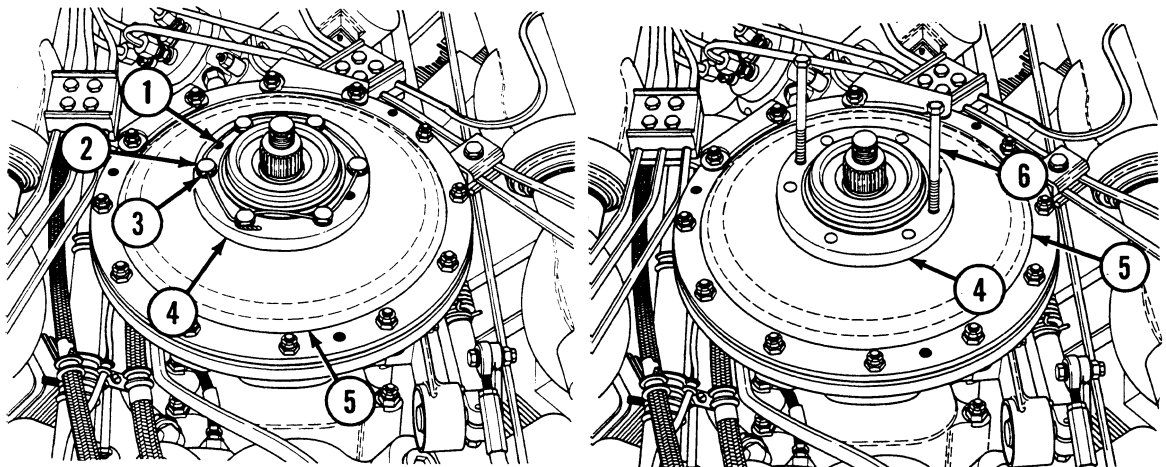

5. Remove gasket (7) from fan drive housing cover (5).

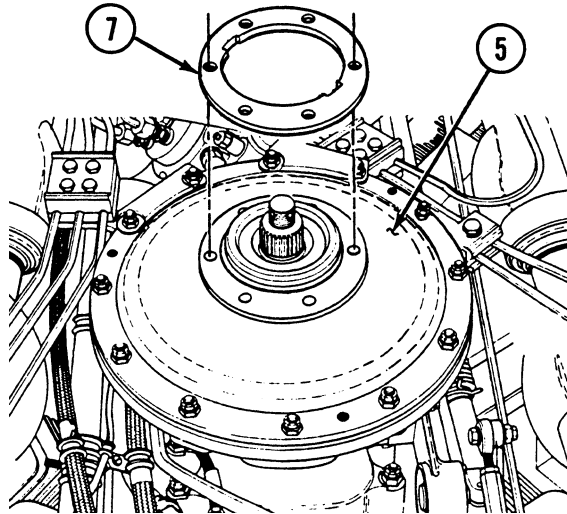

6. Clean fan drive housing cover (5), removing dried adhesive.

Disassembly

1. Drive or press oil seal (8) from oil seal housing (9).

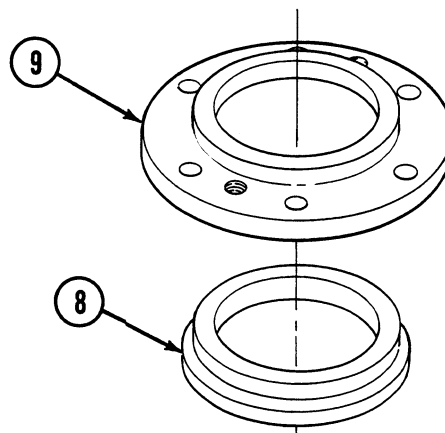

Assembly

CAUTION

Use care to prevent sealing compound from contacting felt.

1. Coat flange face of oil seal (8) with sealing compound.
2. Position oil seal (8) in oil seal housing (9) with lip of seal toward flange surface of housing.
3. Press oil seal (8) in oil seal housing (9) until seal seats against housing flange.
4. Remove excess sealing compound.

Installation

1. Install gasket (7) in fan drive housing cover (5).
2. Install oil seal housing assembly (4) in fan drive housing cover (5) using six flat washers (3) and six screws (2).
3. Install cooling fan (see WP 0144 00) and operate engine (refer to TM 9-2350-256-10) for a short period. Stop engine, remove cooling fan, and check for oil leaks around seal.
4. Install lockwire (1) through screws (2).

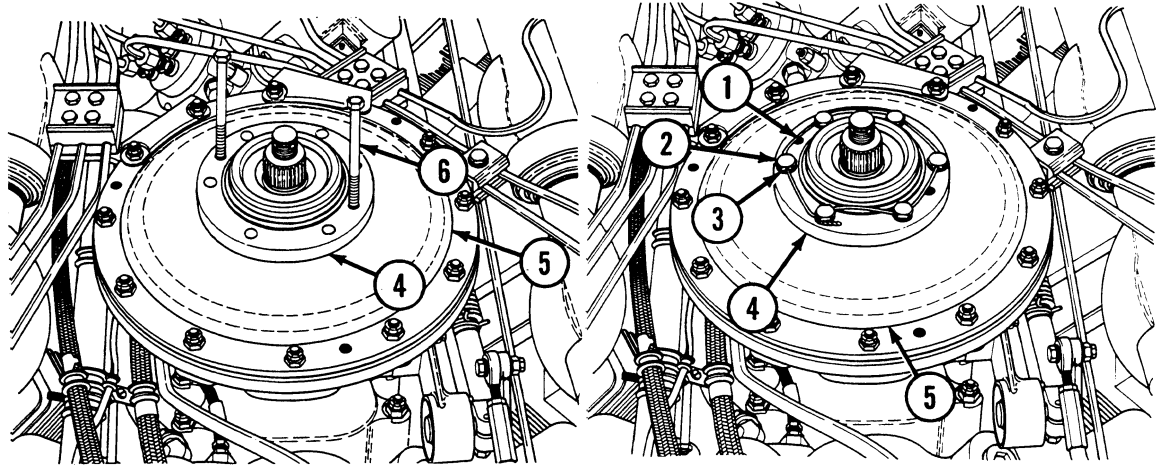
**NOTE**

Follow-on maintenance: Install cooling fans (see WP 0144 00).

END OF WORK PACKAGE

UNIT MAINTENANCE
RECOVERY VEHICLE, FULL TRACKED: MEDIUM, M88A1
NSN 2350-00-122-6826, EIC AQA
ENGINE OIL COOLERS AND SCREENS MAINTENANCE
REMOVAL, INSPECTION, CLEANING, INSTALLATION

INITIAL SETUP:**Tools and Special Tools**

Tool kit, general mechanic's (item 59, WP 0490 00)
 Cleaning tool, oil cooler (item 11, WP 0490 00)

Materials/Parts (cont.)

Washers, flat (16) (item 305, WP 0491 00)
 Washers, flat (4) (item 835, WP 0491 00)

Materials/Parts

Gaskets (4) (item 242, WP 0491 00)
 Gaskets (4) (item 311, WP 0491 00)
 Nuts, self-locking (12) (item 491, WP 0491 00)
 Screws (16) (item 132, WP 0491 00)
 Screws (16) (item 355, WP 0491 00)

Equipment Condition

Powerplant removed (see WP 0098 00)
 Engine oil cooler lines disconnected from oil cooler (see WP 0149 00)
 Transmission oil cooler lines disconnected from oil cooler (see WP 0271 00)

NOTE

The engine and transmission oil coolers can be removed and installed individually. The following procedure applies to both the engine and transmission oil coolers. If only one of the oil coolers is to be replaced, the procedures which apply to the other oil cooler should be skipped.

NOTE

The following procedure applies to both the left- and right-hand oil coolers.

Removal

1. Remove two oil cooler screens (1) by removing eight screws (2) and eight flat washers (3).
2. Disconnect oil cooler vent hose (4) by loosening union nut (5).

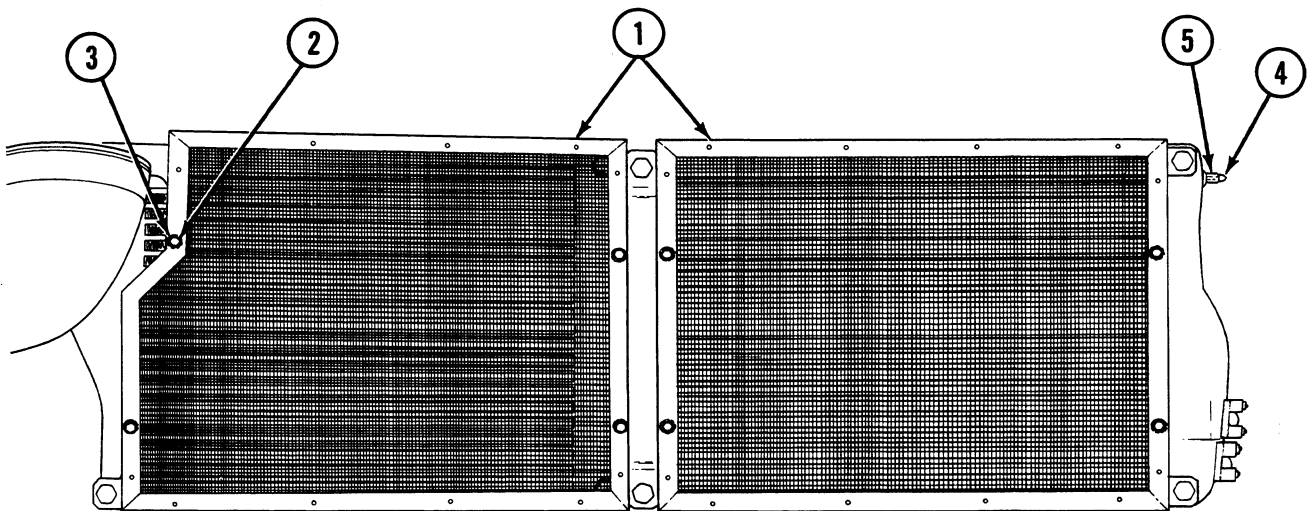

3. Remove two oil coolers (6 and 7) and three oil cooler screen support brackets (8, 9, and 10) by removing eight screws (11) and two flat washers (12).

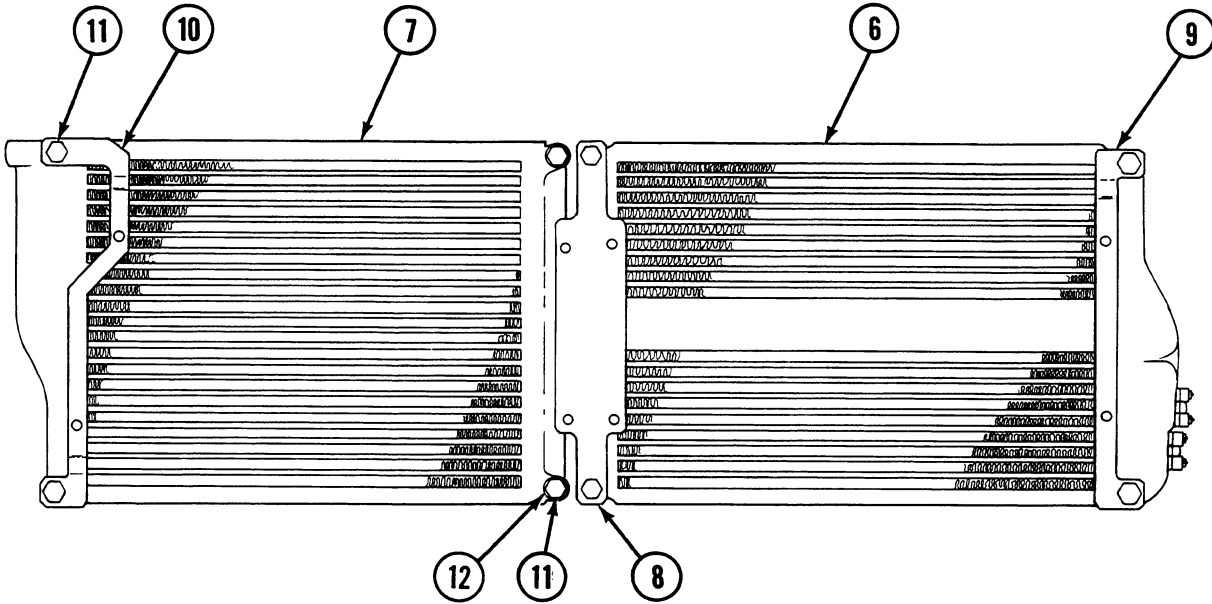

4. Remove engine thermostat (13) and gasket (14).
5. Remove two elbows (15) and two gaskets (16) by removing six self-locking nuts (17).
6. Remove transmission thermostat (18) and gasket (19).

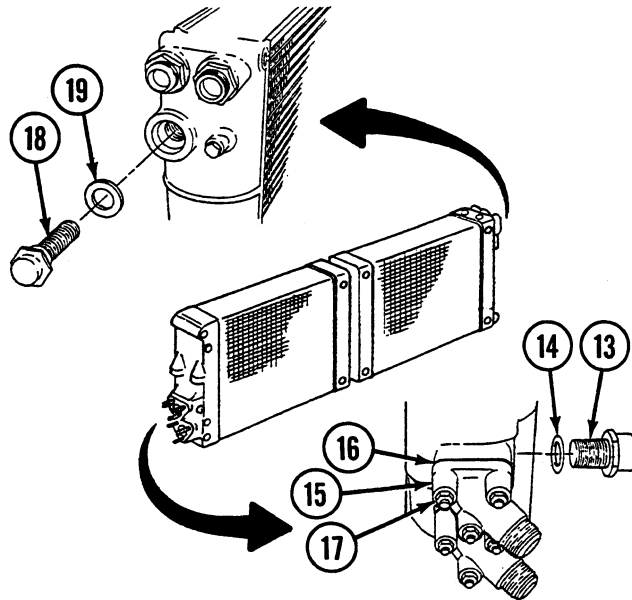

Inspection-Acceptance and Rejection Criteria

1. The coolers must be inspected to ensure that the core and oil cooler screens are clean. Check for cleanliness of the cooler core by shining a flashlight or other visible light through the core.

Cleaning

WARNING

Proper eye, skin, and clothing protection must be worn while operating the cleaning tool or serious injury may occur.

CAUTION

Do not exceed 90 pounds per square inch (psi) (621 kilopascals [kPa]) when cleaning, or damage to the cooler may occur.

NOTE

Oil cooler and screens must be removed in order to use the cleaning tool.

NOTE

The cleaning tool is designed to remove deposits of sand, oil, clay, and other debris from the oil cooler cooling fins while installed in the vehicle. It consists of two tubes connected to a mixing head which produces two high-pressure jets of liquid/air mixture. The air supply tube has a push button valve with a 1/4 in. (6.4 mm) female pipe thread to connect to a 5 cubic-foot (142 liter [L]), 50–90 psi (345–621 kPa) air supply. The liquid supply tube is attached to a 3/8 in. (9.5 mm) inside diameter (i.d.) by 6 foot (1.83 meter) rubber hose for siphoning from a suitable clean container. The cleaning agent can be a solution of detergent and water, or nontoxic, nonflammable solvent and water. Mix one part of detergent or solvent to approximately five parts of water. A solution of detergent or solvent and water is recommended.

NOTE

Use a standard military 5-gallon (19 L) water can to hold the soap solution or cleaning solvent.

NOTE

With the cleaning solution container raised to the approximate level of the surface to be cleaned and the siphon hose extended into the container, press the air supply push button and aim the spray at the surface to be cleaned.

NOTE

When the surface is clean, replace the cleaning solution with water and flush any cleaning solution remaining on the surface.

NOTE

Cleaning may be accomplished with the oil cooler cleaning tool under low pressure. Care must be exercised to ensure that no water or foreign matter enters the oil cooler opening.

Installation

1. Install transmission thermostat (18) and gasket (19).
2. Install two gaskets (16) and two elbows (15) by installing six self-locking nuts (17).
3. Install engine thermostat (13) and gasket (14).

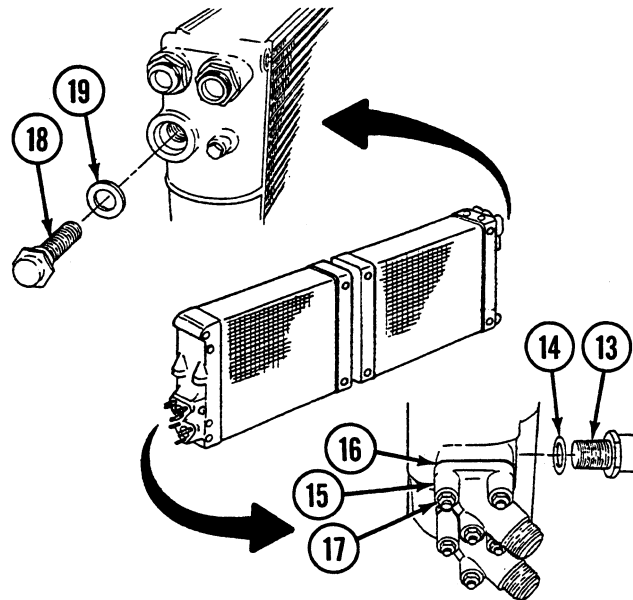

4. Install transmission oil cooler (7) and oil cooler screen support bracket (10) by installing two flat washers (12) and four screws (11).

5. Install oil cooler (6) and two oil cooler screen support brackets (8 and 9) by installing four screws (11).

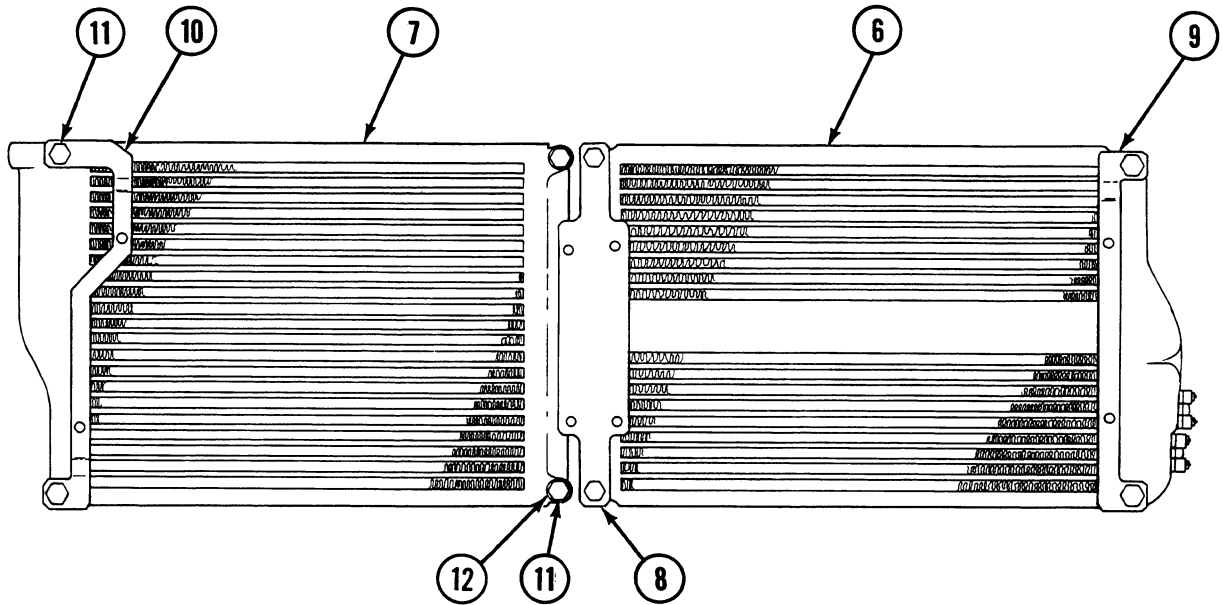

6. Connect oil cooler vent hose (4) by tightening union nut (5).
7. Install two oil cooler screens (1) by installing eight flat washers (3) and eight screws (2).

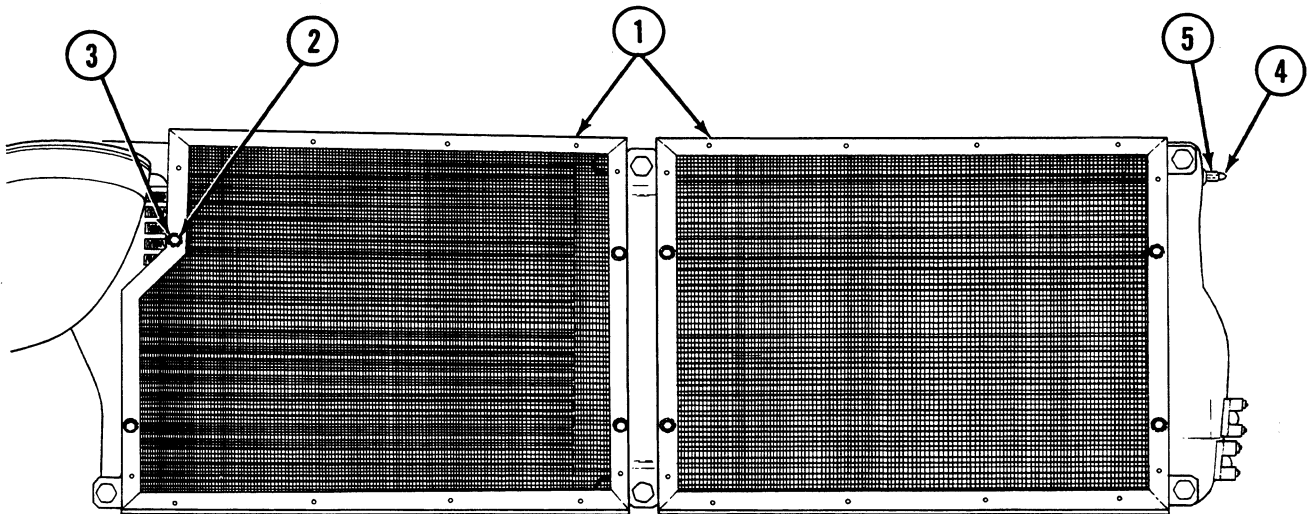

NOTE

Follow-on maintenance: Connect transmission oil cooler lines to transmission oil cooler (see WP 0271 00); Connect engine oil cooler lines to engine oil cooler (see WP 0149 00); Install powerplant (see WP 0098 00).

END OF WORK PACKAGE

UNIT MAINTENANCE
RECOVERY VEHICLE, FULL TRACKED: MEDIUM, M88A1
NSN 2350-00-122-6826, EIC AQA

ENGINE OIL COOLER LINES MAINTENANCE
REMOVAL, CLEANING, INSPECTION, INSTALLATION

INITIAL SETUP:**Tools and Special Tools**

Tool kit, general mechanic's (item 59, WP 0490 00)

References

TM 9-2350-256-10

Materials/Parts

Compound, cleaning (item 9, WP 0489 00)
Gaskets (4) (item 311, WP 0491 00)
Nuts, self-locking (12) (item 491, WP 0491 00)
Nuts, self-locking (2) (item 497, WP 0491 00)
Screws (2) (item 598, WP 0491 00)

Equipment Condition

Engine deck removed (see WP 0336 00)
Powerplant removed (see WP 0098 00)
Engine oil drained

NOTE

The following procedure applies to either the left- or right-hand oil cooler lines.

Removal

1. Remove engine oil cooler inlet line (1) by loosening union nut (2) at each end.
2. Remove loop clamp (3) from engine oil cooler outlet line (4) by removing nut (5) and screw (6).
3. Remove engine oil cooler outlet line (4) by loosening union nut (7) at each end.
4. Remove two elbows (8) by removing three self-locking nuts (9) and gasket (10) from each.

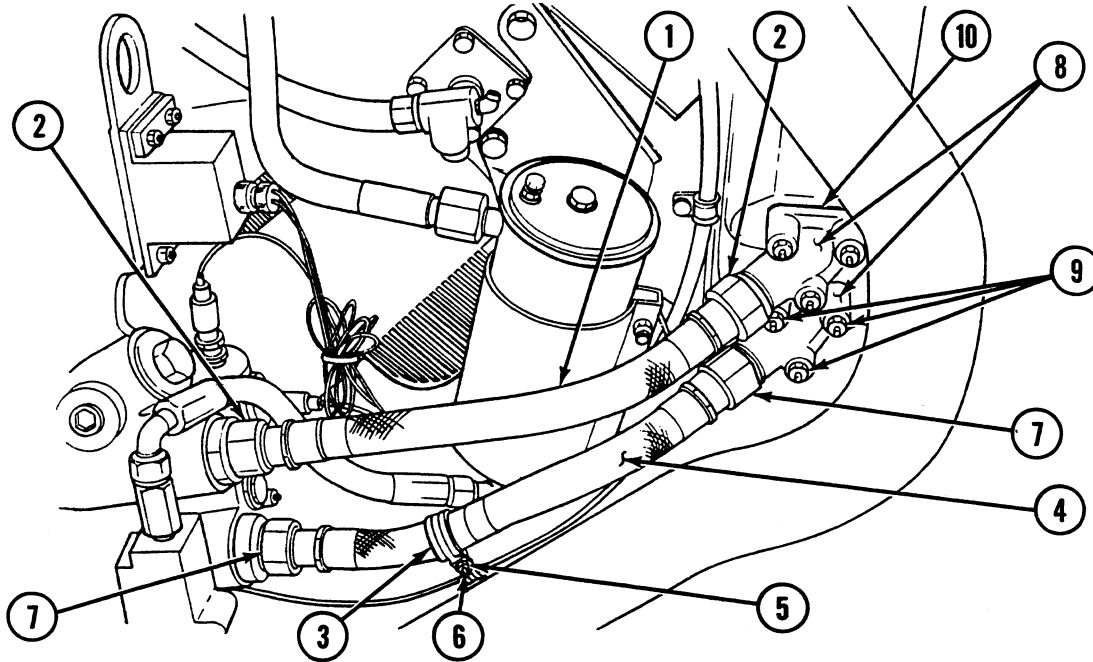

Cleaning

WARNING

Solvents can burn easily, give off harmful vapors, and are harmful to skin and clothing. To avoid injury or death, keep away from open flame and use in a well-ventilated area. If solvent gets on skin or clothing, wash immediately with soap and water.

1. Clean two engine oil cooler lines (1 and 4) and two elbows (8) thoroughly with cleaning compound.

Inspection-Acceptance and Rejection Criteria

1. Replace two elbows (8) if cracked or broken, threads stripped, or otherwise damaged.
2. Remove slight burrs or raised metal from sealing surface with a fine-tooth file, and polish with crocus cloth dipped in dry-cleaning solvent.
3. Replace two engine oil cooler lines (1 and 4) if woven shielding is broken or abraded, union nuts (2 and 7) are cracked, or threads are stripped or damaged

Installation

1. Install two elbows (8) each with gasket (10) and three self-locking nuts (9).
2. Install engine oil cooler outlet line (4) by tightening union nut (7) at each end.
3. Install loop clamp (3) to engine oil cooler outlet line (4) with nut (5) and screw (6).
4. Install engine oil cooler inlet line (1) by tightening union nut (2) at each end.

NOTE

Ensure oil drain valve is tightened to allow for proper system oil flow.

NOTE

Follow-on maintenance: Fill oil (refer to TM 9-2350-256-10); Install powerplant (see WP 0098 00); Replace engine deck (see WP 0336 00).

END OF WORK PACKAGE

INDEX

<u>Subject</u>	<u>WP Sequence No.-Page No.</u>
10-ton snatch block retainer	0377 00-1
25-ton snatch block retainer	0378 00-1
A	
Abbreviations and acronyms	0001 00-3
Accelerator controls	0363 00-1
Accelerator controls, adjustment	0364 00-1
Accelerator controls, alignment	0364 00-1
Accelerator linkages	0363 00-1
Accelerator linkages, adjustment	0364 00-1
Accelerator linkages, alignment	0364 00-1
Access cover, fuel tank filler	0319 00-1
Access cover, hydraulic connections	0292 00-1
Access cover, rear intermediate right	0294 00-1
Access door, APU	0335 00-1
Access door, wire rope roller	0316 00-1
Access doors, engine transmission	0340 00-1
Accessories panel, electrical	0158 00-1
Acetylene and compartment door hardware	0387 00-1
Acetylene hose adapter	0332 00-1
Actuating brake air valve linkage, transmission	0265 00-1
Adjustment of accelerator controls	0364 00-1
Adjustment of accelerator linkages	0364 00-1
Air cleaner	0137 00-1
Air cleaner, APU engine	0433 00-1
Air cleaner inlet covers, left-side	0321 00-1
Air cleaner inlet covers, right-side	0321 00-1
Air cleaner restriction gage assembly	0138 00-1
Air inlet, engine seal	0140 00-1
Air inlet door, left deck	0345 00-1
Air inlet door, right deck	0345 00-1
Air inlet doors	0341 00-1
Air inlet grilles, center-front	0342 00-1
Air inlet grilles, left-front	0342 00-1
Air intake hoses	0139 00-1
Air intake system	0005 00-1
Air intake tube, generator	0111 00-1
Air intake tubes, APU engine	0433 00-1
Air intake water deflector, personnel heater and APU	0397 00-1
Air purifier, M2A2	0440 00-1
Alignment of accelerator controls	0364 00-1
Alignment of accelerator linkages	0364 00-1
Alignment of shifting controls	0362 00-1
Alignment of shifting linkages	0362 00-1

INDEX-Continued

<u>Subject</u>	<u>WP Sequence No.-Page No.</u>
Alignment of steering controls.....	0358 00-1
Alignment of steering linkages.....	0358 00-1
Ammunition rack, caliber .50.....	0386 00-1
Antenna base covers.....	0331 00-1
APU.....	0015 00-1
APU access cover assembly.....	0334 00-1
APU access door.....	0335 00-1
APU air intake water deflector.....	0397 00-1
APU armature relay (single voltage), engine.....	0156 00-1
APU control box.....	0438 00-1
APU cooling air exhaust.....	0434 00-1
APU engine air cleaner.....	0433 00-1
APU engine air cleaner, filter, and air intake tubes.....	0433 00-1
APU engine air intake tubes.....	0433 00-1
APU engine crankcase fill-and-level ID plate.....	0435 00-1
APU engine filter.....	0433 00-1
APU engine fuel filters.....	0436 00-1
APU engine oil filter.....	0437 00-1
APU pressure switch assembly.....	0432 00-1
Arm assembly, compensating.....	0282 00-1
Arm assembly, roadwheel.....	0276 00-1
Army regulations.....	0486 00-1
Army shipping documents.....	0483 00-1
B	
B.O. receiver light.....	0164 00-1
B.O. receiver switch.....	0164 00-1
Batteries.....	0153 00-1
Battery terminal.....	0153 00-1
Battery tray cleaning tubes.....	0333 00-1
Battery trays.....	0153 00-1
Bearing unit housing assembly.....	0368 00-1
Bilge pump outlet cover.....	0320 00-1
Bilge pump power lead circuit breaker.....	0251 00-1
Bilge pump power lead mounting plate.....	0251 00-1
Bilge pump power lead relay.....	0251 00-1
Blocking.....	0483 00-2
Boom, emergency operation of.....	0100 00-1
Boom support.....	0329 00-1
Boxes, hand grenade.....	0383 00-1
Bracket assemblies for side tow bar.....	0375 00-1
Bracket assemblies for side tow cables.....	0375 00-1
Brackets, hand fire extinguisher.....	0384 00-1
Brackets, liquid container.....	0392 00-1

INDEX-Continued

<u>Subject</u>	<u>WP Sequence No.-Page No.</u>
Brackets, M72 LAW rocket launcher	0393 00-1
Brake band adjustment, hoist winch	0410 00-1
Brake band adjustment, main winch	0405 00-1
Brake cam assembly	0367 00-1
Brake pedal	0366 00-1
Brake pedal and bracket assembly	0366 00-1
Breather assembly and line, transmission	0270 00-1
Breather tube, crankcase	0108 00-1
Breather, mechanical transmission	0427 00-1
Bumper spring brackets	0284 00-1
Bumper springs	0284 00-1
Bypass valve, oil cooler pressure-actuated	0110 00-1
C	
Cab-top door, driver's	0313 00-1
Cab-top door, mechanic's	0314 00-1
Cab-top door, rigger's	0315 00-1
Cable, main winch	0408 00-1
Cable identifiers	0255 00-1
Caliber .50 ammunition rack	0386 00-1
Caliber .50 stowage strap	0391 00-1
Center exhaust doors	0347 00-1
Center forward floor plate	0304 00-1
Center front air inlet grilles	0342 00-1
Center rear floor plate	0303 00-1
Center subfloor support	0310 00-1
Check valve, fuel	0126 00-1
Checking unpacked equipment	0094 00-2
Clamp assembly	0338 00-1
Clamps, exhaust manifold	0142 00-1
Cleaner, air	0137 00-1
Cleaning tubes, battery tray	0333 00-1
Commander's cupola assembly	0312 00-1
Commander's plate and switch assembly	0449 00-1
Commander's seat assembly	0350 00-1
Common tools and equipment	0001 00-4
Compensating arm assembly	0282 00-1
Compensating idler	0282 00-1
Compensating idler arm assembly hub assembly	0281 00-1
Compensating idler arm assembly link bearings	0281 00-1
Compensating idler arm assembly links	0281 00-1
Compensating idler arm assembly wheels	0281 00-1
Connecting panel, hydraulic	0418 00-1
Control and linkage, manual, hoist winch	0411 00-1

INDEX-Continued

<u>Subject</u>	<u>WP Sequence No.-Page No.</u>
Control box, APU	0438 00-1
Control box, heater	0161 00-1
Control, engine fuel manual shutoff	0124 00-1
Controls, accelerator	0363 00-1
Controls, accelerator, adjustment of	0364 00-1
Controls, accelerator, alignment of	0364 00-1
Controls, fire extinguisher system	0402 00-1
Controls, main winch	0407 00-1
Controls, service brake	0365 00-1
Controls, shifting	0361 00-1
Controls, shifting, alignment of	0362 00-1
Controls, steering	0357 00-1
Controls, steering, alignment of	0358 00-1
Cooler lines, engine oil	0149 00-1
Cooling air exhaust, APU	0434 00-1
Cooling fan housings, engine	0145 00-1
Cooling fan shroud, engine	0146 00-1
Cooling fan shroud seals, engine	0143 00-1
Cooling fan vertical shaft oil seals, engine	0147 00-1
Cooling fans, engine	0144 00-1
Cooling system	0007 00-1
Corrosion prevention and control	0001 00-2
Cover assembly, APU access	0334 00-1
Cover plates, deep water fording exhaust	0343 00-1
Covers, antenna base	0331 00-1
Covers, drain	0355 00-1
Cradle, engine generator	0150 00-1
Crankcase breather tube	0108 00-1
Cupola assembly, commander's	0312 00-1
Cylinder adjustment, main winch level winder	0404 00-1
Cylinder controls, fire extinguisher	0401 00-1
Cylinder head oil pan drain tubes	0109 00-1
Cylinders, fire extinguisher	0400 00-1
Cylinders and hoisting boom	0414 00-1

D

Damper housing, engine	0104 00-1
Decal markings	0482 00-1
Deck door, engine, right	0337 00-1
Decontamination apparatus bracket assembly, M13	0373 00-1
Deep water fording exhaust cover plates	0343 00-1
Deep water fording kit	0019 00-1
Department of Defense forms	0486 00-1
Department of the Army forms	0486 00-1

INDEX-Continued

<u>Subject</u>	<u>WP Sequence No.-Page No.</u>
Department of the Army pamphlets.....	0486 00-1
Destruction of Army materiel to prevent enemy use	0001 00-2
Differences between models.....	0002 00-27
Dimmer switch, headlight.....	0174 00-1
Directional signal control and mount assembly.....	0453 00-1
Dischargers, M239 launcher.....	0443 00-1
Dome light.....	0183 00-1
Door, APU access.....	0335 00-1
Door, left deck air inlet.....	0345 00-1
Door, left personnel.....	0318 00-1
Door, left stowage compartment.....	0317 00-1
Door, right deck air inlet.....	0345 00-1
Door, right engine deck.....	0337 00-1
Door, right personnel.....	0318 00-1
Door, right stowage compartment.....	0317 00-1
Door, wire rope roller access.....	0316 00-1
Doors, air inlet.....	0341 00-1
Doors, center exhaust.....	0347 00-1
Doors, engine transmission access.....	0340 00-1
Doors, left exhaust.....	0346 00-1
Doors, right exhaust.....	0346 00-1
Drain covers.....	0355 00-1
Drain plugs, transmission torque converter.....	0268 00-1
Drain tubes, cylinder head oil pan.....	0109 00-1
Drain valve, hydraulic.....	0422 00-1
Drain valve controls.....	0354 00-1
Drain valves.....	0353 00-1
Drive couplings, transmission.....	0273 00-1
Driver's bracket and switch assembly.....	0448 00-1
Driver's cab-top door.....	0313 00-1
Driver's headlight dimmer switch.....	0174 00-1
Driver's passive night viewer light.....	0164 00-1
Driver's passive night viewer switch.....	0164 00-1
Driver's periscope blocks.....	0326 00-1
Driver's periscope to infrared power supply (single voltage) (10866967).....	0249 00-1
Driver's periscope vision prisms.....	0326 00-1
Driver's seat assembly.....	0352 00-1
Driver's vision prisms.....	0326 00-1
Dummy connector assembly (infrared and passive night viewer).....	0253 00-1
E	
Electric fuel pump.....	0116 00-1
Electrical accessories panel.....	0158 00-1
Electrical systems and circuits.....	0008 00-1

INDEX–Continued

<u>Subject</u>	<u>WP Sequence No.-Page No.</u>
Electrical troubleshooting.....	0021 00-4
Emergency boom operation.....	0100 00-1
Engine and APU armature relay (single voltage).....	0156 00-1
Engine and APU generator housing (single voltage).....	0156 00-1
Engine cooling fan housings.....	0145 00-1
Engine cooling fan shroud.....	0146 00-1
Engine cooling fan shroud seals.....	0143 00-1
Engine cooling fan vertical shaft oil seals.....	0147 00-1
Engine cooling fans.....	0144 00-1
Engine damper housing.....	0104 00-1
Engine deck.....	0336 00-1
Engine deck, optional.....	0336 00-1
Engine deck base.....	0336 00-1
Engine deck base, optional.....	0336 00-1
Engine fuel manual shutoff control.....	0124 00-1
Engine generator.....	0150 00-1
Engine generator cradle.....	0150 00-1
Engine generator support.....	0150 00-1
Engine idle speed.....	0112 00-1
Engine left upper cover.....	0115 00-1
Engine mounting bracket.....	0101 00-1
Engine oil cooler lines.....	0149 00-1
Engine oil cooler screens.....	0148 00-1
Engine oil coolers.....	0148 00-1
Engine oil filter.....	0104 00-1
Engine oil filter servicing instruction plate.....	0103 00-1
Engine oil pressure sending unit.....	0171 00-1
Engine oil pressure sending unit switch.....	0171 00-1
Engine oil temperature sending unit.....	0171 00-1
Engine oil temperature sending unit switch.....	0171 00-1
Engine rear mount and base assembly.....	0102 00-1
Engine right upper cover.....	0115 00-1
Engine seal, air inlet.....	0140 00-1
Engine solenoid speed.....	0113 00-1
Engine starter.....	0152 00-1
Engine starter bracket.....	0152 00-1
Engine starter solenoid relay.....	0152 00-1
Engine transmission access doors.....	0340 00-1
Equipment characteristics, capabilities, and features.....	0002 00-1
Equipment data.....	0002 00-27
Exhaust deflector.....	0344 00-1
Exhaust manifold clamps.....	0142 00-1
Exhaust pipes.....	0141 00-1

INDEX-Continued

<u>Subject</u>	<u>WP Sequence No.-Page No.</u>
Exhaust smoke generating system	0018 00-1
Exhaust system	0005 00-1
Expendable and durable items list.....	0489 00-1
Exterior straps.....	0394 00-1
External hydraulic reservoir components.....	0421 00-1
External vehicle warning horn.....	0169 00-1
F	
Fan housings, engine cooling.....	0145 00-1
Fan shroud, engine cooling.....	0146 00-1
Fan shroud seals, engine cooling.....	0143 00-1
Fan vertical shaft oil seals, engine cooling.....	0147 00-1
Fastener grade	0485 00-7
Fastener size and thread pattern.....	0485 00-6
Female cable connector replacement (with sleeve).....	0258 00-1
Fenders	0311 00-1
Field manuals	0486 00-1
Filler strainer.....	0120 00-1
Filler tube, oil.....	0106 00-1
Filter, APU engine.....	0433 00-1
Filter, engine oil.....	0104 00-1
Filter, primary fuel.....	0127 00-1
Filter, transmission oil.....	0266 00-1
Filter elements, fuel/water separator.....	0128 00-1
Filter unit, fuel/water separator.....	0129 00-1
Filter unit, M8A3 gas/particulate.....	0016 00-1
Filter unit system, M8A3.....	0439 00-1
Final drive hub	0283 00-1
Final drive sprocket.....	0283 00-1
Fire extinguisher cylinder controls.....	0401 00-1
Fire extinguisher cylinders	0400 00-1
Fire extinguisher interlock switch assembly	0165 00-1
Fire extinguisher system	0011 00-1
Fire extinguisher system controls.....	0402 00-1
Fire extinguisher system lines.....	0403 00-1
Fire extinguisher system linkages	0402 00-1
Fire extinguisher system nozzles	0403 00-1
Fittings, manifold heater.....	0136 00-1
Flasher assembly and related parts	0452 00-1
Flasher light case.....	0388 00-1
Flasher system panel.....	0160 00-1
Flexible shafts and fittings, mechanical speedometer	0356 00-1
Flexible shafts and fittings, mechanical tachometer	0356 00-1
Floor and light mount plate.....	0307 00-1

INDEX–Continued

<u>Subject</u>	<u>WP Sequence No.-Page No.</u>
Floor plate, center forward	0304 00-1
Floor plate, center rear	0303 00-1
Floor plate, fuel transmitter center left access	0299 00-1
Floor plate, hydraulic line intermediate rear right center	0296 00-1
Floor plate, hydraulic valve forward intermediate right.....	0308 00-1
Floor plate, hydraulic valve forward right.....	0288 00-1
Floor plate, intermediate rear left access.....	0305 00-1
Floor plate, intermediate rear left-center	0302 00-1
Floor plate, intermediate rear left-side.....	0301 00-1
Floor plate, intermediate rear right	0290 00-1
Floor plate, rear center.....	0297 00-1
Floor plate, rear intermediate right	0293 00-1
Floor plate, rear intermediate right access.....	0295 00-1
Floor plate, rear left-side	0300 00-1
Floor plate, rear left-side intermediate	0298 00-1
Floor plate, rear right-side	0291 00-1
Floor plate, right-front access.....	0286 00-1
Floor plate, right-front rear access.....	0287 00-1
Floor plate, stowage basket center left.....	0299 00-1
Floor plate, stowage basket forward intermediate left.....	0306 00-1
Floor plate, U-35 winch center right.....	0289 00-1
Fording kit, deep water.....	0019 00-1
Fording kit, pre-installation procedures for	0465 00-1
Front directional signal lamps.....	0455 00-1
Front headlight assembly.....	0175 00-1
Front signal light assembly.....	0177 00-1
Front subfloor support.....	0309 00-1
Fuel check valve	0126 00-1
Fuel control valves and ID plates.....	0125 00-1
Fuel filler tube	0120 00-1
Fuel filter, manifold heater fuel supply	0131 00-1
Fuel filter, personnel heater.....	0399 00-1
Fuel filter, primary	0127 00-1
Fuel filters, APU engine.....	0436 00-1
Fuel flow regulator	0419 00-1
Fuel injection pump.....	0252 00-1
Fuel injector fuel return hose	0119 00-1
Fuel injector tubes and brackets.....	0114 00-1
Fuel level transmitter.....	0121 00-1
Fuel lines, manifold heater	0136 00-1
Fuel pump, electric.....	0116 00-1
Fuel pump, personnel heater.....	0398 00-1
Fuel pump (gear type) and lines.....	0118 00-1

INDEX-Continued

<u>Subject</u>	<u>WP Sequence No.-Page No.</u>
Fuel return hose, fuel injector	0119 00-1
Fuel shutoff solenoid	0252 00-1
Fuel shutoff valve assembly	0447 00-1
Fuel supply system	0005 00-1
Fuel tank filler access cover	0319 00-1
Fuel transfer pump	0419 00-1
Fuel transfer pump hoses	0117 00-1
Fuel transmitter center left floor access plate	0299 00-1
Fuel tube assemblies	0446 00-1
Fuel valve lines and fittings	0123 00-1
Fuel/water separator automatic drain system	0130 00-1
Fuel/water separator filter elements	0128 00-1
Fuel/water separator filter unit	0129 00-1
G	
Gage assembly, air cleaner restriction	0138 00-1
Gage panel assembly	0157 00-1
Gage rod, transmission	0269 00-1
Gear type fuel pump	0118 00-1
Generator, engine	0150 00-1
Generator air intake tube	0111 00-1
Generator relay and housing (single voltage), engine and APU	0156 00-1
Grilles, air inlet, center-front	0342 00-1
Grilles, air inlet, left-front	0342 00-1
Groundhop instructions	0099 00-1
Guide bars, transmission	0330 00-1
H	
Hand fire extinguisher brackets	0384 00-1
Hand grenade boxes	0383 00-1
Harnesses, wiring:	
7972352	0213 00-1
10866909	0219 00-1
10866950	0214 00-1
10894548	0235 00-1
10894850-4	0226 00-1
10944744	0196 00-1
10945008	0233 00-1
11671226	0206 00-1
11671324	0225 00-1
11671353	0236 00-1
11671356	0239 00-1
11671420	0203 00-1
11671568	0201 00-1

INDEX-Continued

<u>Subject</u>	<u>WP Sequence No.-Page No.</u>
11671789.....	0223 00-1
11671790.....	0221 00-1
11671791.....	0191 00-1
11671792.....	0189 00-1
11671793.....	0230 00-1
11671795.....	0205 00-1
11671796.....	0218 00-1
11671798.....	0202 00-1
11671799.....	0229 00-1
11671807.....	0195 00-1
11671813.....	0220 00-1
11671816.....	0208 00-1
11672273.....	0216 00-1
11672298-1.....	0254 00-1
11672298-2.....	0254 00-1
11672299.....	0240 00-1
11672315.....	0241 00-1
11672366.....	0237 00-1
11672371.....	0215 00-1
11672373.....	0197 00-1
11672382.....	0242 00-1
11672386.....	0244 00-1
11672387.....	0243 00-1
11672412.....	0224 00-1
11672413.....	0190 00-1
11672415.....	0192 00-1
11672416.....	0207 00-1
11672417.....	0227 00-1
11672466.....	0228 00-1
11684127.....	0245 00-1
12314651.....	0209 00-1
12314745.....	0210 00-1
12322547.....	0204 00-1
12322586.....	0193 00-1
12322587.....	0194 00-1
12322588.....	0222 00-1
12322611.....	0456 00-1
12322612.....	0458 00-1
12322613.....	0457 00-1
12322614.....	0459 00-1
12322615-1.....	0460 00-1
12322615-2.....	0460 00-1
12322648.....	0463 00-1

INDEX-Continued

<u>Subject</u>	<u>WP Sequence No.-Page No.</u>
12322658.....	0464 00-1
12322660.....	0462 00-1
12322668.....	0461 00-1
Headlight assembly, front.....	0175 00-1
Headlight dimmer switch.....	0174 00-1
Heater, personnel.....	0396 00-1
Heater control box.....	0161 00-1
High beam indicator light assembly.....	0182 00-1
Hoist winch brake band adjustment.....	0410 00-1
Hoist winch hose and cable assembly.....	0409 00-1
Hoist winch manual control and linkage.....	0411 00-1
Hoisting boom.....	0012 00-2
Hoisting boom and cylinders.....	0414 00-1
Holder, machine gun and rifle.....	0383 00-1
Horn, external vehicle warning.....	0169 00-1
Horn, powerplant warning.....	0170 00-1
Hose, fuel injector fuel return.....	0119 00-1
Hose and cable assembly, hoist winch.....	0409 00-1
Hoses, air intake.....	0139 00-1
Hoses, fuel transfer pump.....	0117 00-1
Hoses, main winch.....	0407 00-1
Hoses, spade cylinder.....	0431 00-1
Housing, master relay (dual and single voltage).....	0151 00-1
Hub, final drive.....	0283 00-1
Hub assembly, compensating idler arm assembly.....	0281 00-1
Hub assembly, roadwheel.....	0277 00-1
Hydraulic connecting panel.....	0418 00-1
Hydraulic connections access cover.....	0292 00-1
Hydraulic drain valve and related parts.....	0422 00-1
Hydraulic fittings.....	0417 00-1
Hydraulic fittings, mechanical transmission and hydraulic pump.....	0416 00-1
Hydraulic line intermediate rear right center floor plate.....	0296 00-1
Hydraulic lines.....	0417 00-1
Hydraulic lines, mechanical transmission and hydraulic pump.....	0416 00-1
Hydraulic oil reservoir strainer.....	0424 00-1
Hydraulic reservoir components, external.....	0421 00-1
Hydraulic subplate ID plate.....	0423 00-1
Hydraulic system, main.....	0014 00-1
Hydraulic system oil filter.....	0420 00-1
Hydraulic troubleshooting.....	0021 00-3
Hydraulic valve forward intermediate right floor plate.....	0308 00-1
Hydraulic valve forward right floor plate.....	0288 00-1

INDEX-Continued

<u>Subject</u>	<u>WP Sequence No.-Page No.</u>
I	
ID plate, APU engine crankcase fill-and-level.....	0435 00-1
ID plate, hydraulic subplate.....	0423 00-1
ID plate, mechanical transmission.....	0426 00-1
ID plate, vehicle.....	0395 00-1
ID plates, fuel control valves.....	0125 00-1
Identifiers, cable.....	0255 00-1
Identifiers, plug.....	0255 00-1
Identifiers, receptacle.....	0255 00-1
Identifiers, wire.....	0255 00-1
Idle speed, engine.....	0112 00-1
Idler, compensating.....	0282 00-1
Ignition unit, manifold heater.....	0132 00-1
Indicator, oil level.....	0105 00-1
Infrared power supply.....	0324 00-1
Infrared power supply (single voltage) (10866967), driver's periscope to.....	0249 00-1
Inlet covers, left-side air cleaner.....	0321 00-1
Inlet covers, right-side air cleaner.....	0321 00-1
Inspection, receiving.....	0483 00-1
Inspection during storage.....	0483 00-2
Instruction plate, engine oil filter servicing.....	0103 00-1
Insulation retainer.....	0339 00-1
Interior straps.....	0394 00-1
Interlock switch assembly, fire extinguisher.....	0165 00-1
Intermediate rear left access floor plate.....	0305 00-1
Intermediate rear left-center floor plate.....	0302 00-1
Intermediate rear left-side floor plate.....	0301 00-1
Intermediate rear right floor plate.....	0290 00-1
L	
Launcher system, M239 smoke grenade.....	0017 00-1
Lead assemblies:	
10866881.....	0200 00-1
10866904.....	0186 00-1
10887570.....	0188 00-1
10894546.....	0234 00-1
10911920.....	0217 00-1
10945007.....	0232 00-1
11671227-2.....	0198 00-1
11671227-3.....	0199 00-1
11671357.....	0185 00-1
11671362.....	0211 00-1
11671794.....	0231 00-1
11671811.....	0187 00-1

INDEX-Continued

<u>Subject</u>	<u>WP Sequence No.-Page No.</u>
11672385.....	0246 00-1
11672473-1.....	0247 00-1
11672473-2.....	0248 00-1
12322589.....	0212 00-1
12322604.....	0238 00-1
Left deck air inlet door.....	0345 00-1
Left exhaust doors.....	0346 00-1
Left front track support bracket.....	0280 00-1
Left front track support roller.....	0280 00-1
Left front track support wheel.....	0280 00-1
Left personnel door.....	0318 00-1
Left personnel step assembly.....	0322 00-1
Left side oddment tray.....	0390 00-1
Left stowage compartment door.....	0317 00-1
Left-front air inlet grilles.....	0342 00-1
Left-side air cleaner inlet covers.....	0321 00-1
Lever assembly.....	0370 00-1
Limit valve adjustment, stayline cylinder.....	0415 00-1
Limited storage instructions.....	0483 00-1
Lines, fixed fire extinguisher system.....	0403 00-1
Lines and fittings, fuel valve.....	0123 00-1
Link bearings, compensating idler arm assembly.....	0281 00-1
Linkage roller plates.....	0371 00-1
Linkages, accelerator.....	0363 00-1
Linkages, accelerator, adjustment of.....	0364 00-1
Linkages, accelerator, alignment of.....	0364 00-1
Linkages, fire extinguisher system.....	0402 00-1
Linkages, service brake.....	0365 00-1
Linkages, shifting.....	0361 00-1
Linkages, shifting, alignment of.....	0362 00-1
Linkages, steering.....	0357 00-1
Linkages, steering, alignment of.....	0358 00-1
Links, compensating idler arm assembly.....	0281 00-1
Liquid container brackets.....	0392 00-1
Loading.....	0483 00-2
Location and description of major components.....	0002 00-2
Low pressure switch, mechanical transmission lubrication oil.....	0167 00-1
Lubrication fitting, spade release.....	0430 00-1
Lubrication instructions.....	0097 00-1
Lubrication line, spade cable (manual spade release).....	0429 00-1
Lubrication line, spade release (hydraulic spade release).....	0428 00-1
Lubrication system.....	0004 00-1

INDEX-Continued

<u>Subject</u>	<u>WP Sequence No.-Page No.</u>
M	
M13 decontamination apparatus bracket assembly	0373 00-1
M239 launcher dischargers.....	0443 00-1
M239 launcher power switch box assembly	0442 00-1
M239 launcher stowage boxes.....	0444 00-1
M239 smoke grenade launcher system.....	0017 00-1
M2A2 air purifier.....	0440 00-1
M72 LAW rocket launcher brackets.....	0393 00-1
M8A3 filter unit switch assembly	0441 00-1
M8A3 filter unit system.....	0439 00-1
M8A3 gas/particulate filter unit.....	0016 00-1
Machine gun and rifle holders	0383 00-1
Main hydraulic system	0014 00-1
Main hydraulic system pump.....	0013 00-1
Main switch panel assembly.....	0159 00-1
Main winch brake band adjustment.....	0405 00-1
Main winch cable	0408 00-1
Main winch controls and hoses	0407 00-1
Main winch level winder cylinder adjustment.....	0404 00-1
Main winch manual control and linkage.....	0406 00-1
Maintenance allocation chart (MAC).....	0488 00-1
Maintenance forms, records, and reports.....	0001 00-2
Maintenance functions.....	0487 00-1
Male cable connector replacement	0257 00-1
Mandatory replacement parts.....	0491 00-1
Manifold air induction heater system	0006 00-1
Manifold clamps, exhaust	0142 00-1
Manifold heater fuel lines and fittings	0136 00-1
Manifold heater fuel return solenoid valve.....	0133 00-1
Manifold heater fuel supply fuel filter	0131 00-1
Manifold heater fuel supply solenoid valve.....	0131 00-1
Manifold heater ignition unit.....	0132 00-1
Manifold heater nozzle assembly.....	0134 00-1
Manifold heater operation check.....	0135 00-1
Manual control and linkage, hoist winch.....	0411 00-1
Manual control and linkage, main winch.....	0406 00-1
Manufactured items.....	0484 00-1
Markings, painting and restenciling.....	0002 00-22
Master relay housing (dual and single voltage).....	0151 00-1
Mechanic's cab-top door.....	0314 00-1
Mechanic's periscope block.....	0327 00-1
Mechanic's periscope vision prisms.....	0327 00-1
Mechanic's seat assembly.....	0352 00-1

INDEX–Continued

<u>Subject</u>	<u>WP Sequence No.-Page No.</u>
Mechanical speedometer flexible shafts and fittings.....	0356 00-1
Mechanical tachometer flexible shafts and fittings.....	0356 00-1
Mechanical transmission	0013 00-1
Mechanical transmission breather and oil level gage	0427 00-1
Mechanical transmission ID plate.....	0426 00-1
Mechanical transmission lubrication oil low pressure switch	0167 00-1
Mechanical troubleshooting.....	0021 00-2
Mirror and mount assemblies.....	0454 00-1
Mount plate, floor and light.....	0307 00-1
Mounting bracket, engine.....	0101 00-1
N	
Neutral safety switch.....	0163 00-1
Night viewer light.....	0164 00-1
Night viewer mount.....	0323 00-1
Night viewer switch.....	0164 00-1
Nomenclature cross-reference	0001 00-3
Nonslip walkway coating.....	0348 00-1
Nozzle assembly, manifold heater.....	0134 00-1
Nozzles, fixed fire extinguisher system	0403 00-1
O	
Oddment tray, left side	0390 00-1
Oil cooler lines, engine.....	0149 00-1
Oil cooler lines, transmission.....	0271 00-1
Oil cooler pressure-actuated bypass valve.....	0110 00-1
Oil coolers and screens, engine.....	0148 00-1
Oil filler tube and related parts.....	0106 00-1
Oil filter, APU engine.....	0437 00-1
Oil filter, engine	0104 00-1
Oil filter, hydraulic system.....	0420 00-1
Oil filter, transmission.....	0266 00-1
Oil level gage	0427 00-1
Oil level indicator and related parts.....	0105 00-1
Oil pan	0107 00-1
Oil pan drain tubes, cylinder head	0109 00-1
Oil temperature transmitter and switch housing assembly.....	0425 00-1
Operation check, manifold heater	0135 00-1
Optional engine deck.....	0336 00-1
Optional engine deck base.....	0336 00-1
Output reduction drives, transmission.....	0273 00-1
Oxygen tank strap assemblies.....	0379 00-1

INDEX-Continued

<u>Subject</u>	<u>WP Sequence No.-Page No.</u>
P	
Painting and restenciling markings.....	0002 00-22
Panel, electrical accessories.....	0158 00-1
Panel, flasher system.....	0160 00-1
Panel assembly, gage.....	0157 00-1
Panel assembly, main switch.....	0159 00-1
Passive night viewer light, driver's	0164 00-1
Passive night viewer mount.....	0323 00-1
Passive night viewer stowage box.....	0383 00-1
Passive night viewer switch, driver's	0164 00-1
Periscope block, mechanic's.....	0327 00-1
Periscope blocks, driver's	0326 00-1
Periscope blocks, rigger's	0326 00-1
Periscope quick-release mount (infrared night viewer).....	0325 00-1
Periscope vision prisms, driver's.....	0326 00-1
Periscope vision prisms, mechanic's.....	0327 00-1
Periscope vision prisms, rigger's.....	0326 00-1
Personnel heater	0396 00-1
Personnel heater air intake water deflector	0397 00-1
Personnel heater fuel filter	0399 00-1
Personnel heater fuel pump.....	0398 00-1
Personnel seat assemblies.....	0349 00-1
Pioneer tool set bracket.....	0380 00-1
Plate assembly	0369 00-1
Plug identifiers.....	0255 00-1
PMCS.....	0096 00-1
PMCS general procedures.....	0095 00-1
PMCS special intervals.....	0095 00-2
Power control lever switch.....	0166 00-1
Power supply, infrared.....	0324 00-1
Powerplant	0003 00-1
Powerplant replacement.....	0098 00-1
Powerplant warning horn	0170 00-1
Pre-installation procedures for fording kit.....	0465 00-1
Preparation for shipment.....	0483 00-1
Preparation for storage or shipment.....	0001 00-3
Preservatives.....	0483 00-1
Primary fuel filter	0127 00-1
Processing unpacked equipment.....	0094 00-2
Pump, fuel injection.....	0252 00-1
Pump, fuel transfer.....	0419 00-1
Pump, main hydraulic system	0013 00-1
Purge pump/handle/lever.....	0122 00-1

INDEX-Continued

<u>Subject</u>	<u>WP Sequence No.-Page No.</u>
R	
Radio interference suppression	0020 00-1
Rail carrier limitation accommodations.....	0483 00-3
Rail clearance, vehicle size reduction to accommodate	0483 00-2
Rear center floor plate.....	0297 00-1
Rear intermediate right access cover.....	0294 00-1
Rear intermediate right access floor plate	0295 00-1
Rear intermediate right floor plate	0293 00-1
Rear left-side floor plate	0300 00-1
Rear left-side intermediate floor plate.....	0298 00-1
Rear mount and base assembly, engine.....	0102 00-1
Rear right-side floor plate	0291 00-1
Rear subfloor support	0310 00-1
Receiving inspection.....	0483 00-1
Receptacle identifiers	0255 00-1
Reflectors and mounting plates.....	0451 00-1
Regulator, fuel flow	0419 00-1
Regulator, voltage (dual voltage) (11672403).....	0154 00-1
Regulator, voltage (single voltage) (11659111-1).....	0155 00-1
Relay box assembly, switching (single voltage regulator).....	0162 00-1
Removal from limited storage.....	0483 00-2
Repair parts	0001 00-4
Reservoir strainer, hydraulic oil.....	0424 00-1
Retainer, 10-ton snatch block.....	0377 00-1
Retainer, 25-ton snatch block.....	0378 00-1
Retainer, insulation.....	0339 00-1
Retainers, track link	0377 00-1
Rigger's cab-top door.....	0315 00-1
Rigger's fixed spotlight.....	0181 00-1
Rigger's periscope blocks	0326 00-1
Rigger's periscope vision prisms.....	0326 00-1
Rigger's seat assembly.....	0351 00-1
Rigger's service light.....	0176 00-1
Rigger's service light switch	0173 00-1
Rigger's vision prisms.....	0326 00-1
Right and left upper covers, engine	0115 00-1
Right deck air inlet door.....	0345 00-1
Right engine deck door	0337 00-1
Right exhaust doors.....	0346 00-1
Right personnel door.....	0318 00-1
Right personnel step assembly	0322 00-1
Right stowage compartment door	0317 00-1
Right-front access floor plate.....	0286 00-1

INDEX-Continued

<u>Subject</u>	<u>WP Sequence No.-Page No.</u>
Right-front floor plate rear access	0287 00-1
Right-side air cleaner inlet covers	0321 00-1
Roadwheel arm assembly.....	0276 00-1
Roadwheel attaching hardware	0381 00-1
Roadwheel hub assembly	0277 00-1
Roadwheel support housing	0278 00-1
Roadwheels.....	0274 00-1
Rocket ammunition stowage box	0385 00-1
Roller bracket assembly, transmission.....	0267 00-1
Roller plates, linkage.....	0371 00-1
S	
Saddle seals, transmission	0272 00-1
Safety switch, neutral.....	0163 00-1
Sampling valve, transmission	0271 00-1
Seat assembly, commander's.....	0350 00-1
Seat assembly, driver's.....	0352 00-1
Seat assembly, mechanic's.....	0352 00-1
Seat assembly, personnel.....	0349 00-1
Seat assembly, rigger's.....	0351 00-1
Sending unit, engine oil pressure	0171 00-1
Sending unit, engine oil temperature.....	0171 00-1
Sending unit, transmission oil pressure.....	0168 00-1
Sending unit, transmission oil temperature	0168 00-1
Service brake controls	0365 00-1
Service brake linkages.....	0365 00-1
Service light, rigger's.....	0176 00-1
Service light switch, rigger's.....	0173 00-1
Shield, wire rope	0412 00-1
Shifting controls	0361 00-1
Shifting controls, alignment of.....	0362 00-1
Shifting linkages.....	0361 00-1
Shifting linkages, alignment of.....	0362 00-1
Shock absorbers.....	0285 00-1
Shroud seals, engine cooling fan	0143 00-1
Side tow bar, bracket assemblies	0375 00-1
Side tow cables, bracket assemblies.....	0375 00-1
Signal light assembly, front.....	0177 00-1
Solenoid, fuel shutoff.....	0252 00-1
Solenoid relay, engine starter.....	0152 00-1
Solenoid speed, engine.....	0113 00-1
Solenoid valve assemblies and bracket.....	0445 00-1
Solenoid valve, fuel/water separator automatic drain system.....	0130 00-1
Solenoid valve, manifold heater fuel return.....	0133 00-1

INDEX–Continued

<u>Subject</u>	<u>WP Sequence No.-Page No.</u>
Solenoid valve, manifold heater fuel supply.....	0131 00-1
Spade assembly.....	0012 00-1
Spade cable lubrication line (manual spade release).....	0429 00-1
Spade cylinder hoses.....	0431 00-1
Spade release and lubrication line (hydraulic spade release).....	0428 00-1
Spade release lubrication fitting.....	0430 00-1
Spare headlight mount base assembly.....	0178 00-1
Special intervals, PMCS.....	0095 00-2
Special tools, TMDE, and support equipment.....	0001 00-4
Speed adjustment, engine idle.....	0112 00-1
Speed adjustment, engine solenoid.....	0113 00-1
Speedometer flexible shafts and fittings, mechanical.....	0356 00-1
Spotlight, fixed.....	0181 00-1
Sprocket, final drive.....	0283 00-1
Sprocket attaching hardware.....	0381 00-1
Standard form.....	0486 00-1
Starter, engine.....	0152 00-1
Starter bracket, engine.....	0152 00-1
Stayline cylinder limit valve adjustment.....	0415 00-1
STE/ICE-R vehicle troubleshooting.....	0040 00-1
Steering control assembly.....	0359 00-1
Steering control housing assembly.....	0360 00-1
Steering controls, alignment of.....	0358 00-1
Steering controls and linkages.....	0357 00-1
Steering linkages, alignment of.....	0358 00-1
Step assembly, left personnel.....	0322 00-1
Step assembly, right personnel.....	0322 00-1
Stoplight switch.....	0172 00-1
Stoplight-taillight assemblies.....	0179 00-1
Stoplights and covers.....	0450 00-1
Storage, inspection during.....	0483 00-2
Stowage basket center left floor plate.....	0299 00-1
Stowage basket forward intermediate left floor plate.....	0306 00-1
Stowage baskets.....	0382 00-1
Stowage box, passive night viewer.....	0383 00-1
Stowage box, rocket ammunition.....	0385 00-1
Stowage boxes, M239 launcher.....	0444 00-1
Stowage compartment door, left.....	0317 00-1
Stowage compartment door, right.....	0317 00-1
Stowage strap, caliber .50.....	0391 00-1
Straps, exterior.....	0394 00-1
Straps, interior.....	0394 00-1
Subfloor support, center.....	0310 00-1

INDEX–Continued

<u>Subject</u>	<u>WP Sequence No.-Page No.</u>
Subfloor support, front	0309 00-1
Subfloor support, rear	0310 00-1
Support, engine generator.....	0150 00-1
Support bracket, track.....	0279 00-1
Support bracket, track, left front.....	0280 00-1
Support housing, roadwheel.....	0278 00-1
Support roller, track.....	0279 00-1
Support roller, track, left front.....	0280 00-1
Support wheel, track.....	0279 00-1
Support wheel, track, left front.....	0280 00-1
Support wheel attaching hardware.....	0381 00-1
Suspension systems.....	0010 00-1
Switch assembly, APU pressure	0432 00-1
Switch assembly, M8A3 filter unit.....	0441 00-1
Switch box assembly, power, M239 launcher.....	0442 00-1
Switch panel assembly, main.....	0159 00-1
Switching relay box assembly (single voltage reguator).....	0162 00-1

T

Tachometer flexible shafts and fittings, mechanical.....	0356 00-1
Taillight assemblies.....	0179 00-1
Tarpaulin tray.....	0376 00-1
Technical bulletins.....	0486 00-2
Technical manuals.....	0486 00-2
Temperature transmitter, oil.....	0425 00-1
Terminal, battery.....	0153 00-1
Terminal-type cable connector replacement.....	0256 00-1
Tightening metal fasteners.....	0485 00-5
Tool ID list.....	0490 00-1
Toolbox rack.....	0389 00-1
Tools and test equipment.....	0488 00-1
Torque converter drain plugs, transmission.....	0268 00-1
Torque limits.....	0485 00-2
Torsion bar.....	0275 00-1
Torsion bar anchors.....	0275 00-1
Tow bar, side, bracket assemblies for.....	0375 00-1
Tow bar assembly.....	0374 00-1
Tow bar mounting brackets.....	0374 00-1
Tow cables, side, bracket assemblies for.....	0375 00-1
Tow chain mounting brackets.....	0374 00-1
Towing pintle and mount.....	0328 00-1
Towing pintle mount.....	0328 00-1
Track link retainers.....	0377 00-1
Track support bracket.....	0279 00-1

INDEX-Continued

<u>Subject</u>	<u>WP Sequence No.-Page No.</u>
Track support bracket, left front.....	0280 00-1
Track support roller.....	0279 00-1
Track support roller, left front.....	0280 00-1
Track support wheel.....	0279 00-1
Track support wheel, left front.....	0280 00-1
Track wrench bracket.....	0386 00-1
Tracks and suspension systems.....	0010 00-1
Transmission, mechanical.....	0013 00-1
Transmission access doors, engine.....	0340 00-1
Transmission actuating brake air valve linkage.....	0265 00-1
Transmission and output reduction drives.....	0009 00-1
Transmission breather assembly and line.....	0270 00-1
Transmission drive couplings.....	0273 00-1
Transmission gage rod.....	0269 00-1
Transmission guide bars.....	0330 00-1
Transmission oil cooler lines.....	0271 00-1
Transmission oil filter.....	0266 00-1
Transmission oil pressure sending unit.....	0168 00-1
Transmission oil temperature sending unit.....	0168 00-1
Transmission output reduction drives.....	0273 00-1
Transmission roller bracket assembly.....	0267 00-1
Transmission saddle seals.....	0272 00-1
Transmission sampling valve.....	0271 00-1
Transmission torque converter drain plugs.....	0268 00-1
Transmitter, fuel level.....	0121 00-1
Transmitter, oil temperature.....	0425 00-1
Transportability data.....	0483 00-6
Trays, battery.....	0153 00-1
Troublelight assembly.....	0180 00-1
Troubleshooting, electrical.....	0021 00-4
Troubleshooting, hydraulic.....	0021 00-3
Troubleshooting, mechanical.....	0021 00-2
Typical female-type panel mounting receptacle.....	0259 00-1
Typical female-type panel mounting receptacle (with ridged locking nut).....	0261 00-1
Typical female-type plug.....	0263 00-1
Typical male-type panel mounting receptacle.....	0260 00-1
Typical male-type panel mounting receptacle (with ridged locking nut).....	0262 00-1
Typical male-type plug.....	0264 00-1
U	
U-35 winch center right floor plate.....	0289 00-1
Unpacked equipment, checking.....	0094 00-2
Unpacked equipment, processing.....	0094 00-2
Upper covers, engine right and left.....	0115 00-1

INDEX–Continued

<u>Subject</u>	<u>WP Sequence No.-Page No.</u>
V	
Valve controls, drain.....	0354 00-1
Valves, drain.....	0353 00-1
Vehicle ID plate.....	0395 00-1
Vehicle size reduction to accomodate rail clearance.....	0483 00-2
Vehicle warning horn, external.....	0169 00-1
Ventilator blower assembly.....	0250 00-1
Vertical shaft oil seals, engine cooling fan.....	0147 00-1
Vise.....	0372 00-1
Vise mounting adapter plate.....	0372 00-1
Vise mounting hardware.....	0372 00-1
Vision prisms, driver's.....	0326 00-1
Vision prisms, rigger's.....	0326 00-1
Voltage regulator (dual voltage) (11672403).....	0154 00-1
Voltage regulator (single voltage) (11659111-1).....	0155 00-1
W	
Walkway coating, nonslip.....	0348 00-1
Warning horn, external vehicle.....	0169 00-1
Warning horn, powerplant.....	0170 00-1
Wheels, compensating idler arm assembly.....	0281 00-1
Winch illumination lamp assembly.....	0184 00-1
Winches, spade assembly, and hoisting boom.....	0012 00-1
Wire identifiers.....	0255 00-1
Wire rope roller access door.....	0316 00-1
Wire rope roller bearing assembly.....	0413 00-1
Wire rope roller housing.....	0413 00-1
Wire rope shield.....	0412 00-1

RECOMMENDED CHANGES TO PUBLICATIONS AND BLANK FORMS						Use Part II (reverse) for Repair Parts and Special Tool Lists (RPSTL) and Supply Catalogs/Supply Manuals (SC/SM).	DATE Date you filled out this form.
For use of this form, see AR 25-30; the proponent agency is ODISC4.							
TO: (Forward to proponent of publication or form) (Include ZIP Code) AMSTALC-LMIT / TECH PUBS, TACOM-RI 1 Rock Island Arsenal Rock Island, IL 61299-7630						FROM: (Activity and location) (Include ZIP Code) Your mailing address	
PART I – ALL PUBLICATIONS (EXCEPT RPSTL AND SC/SM) AND BLANK FORMS							
PUBLICATION/FORM NUMBER TM 9-2350-256-20-1				DATE 27 November 2005	TITLE Recovery Vehicle, Full Tracked: Medium, M88A1		
ITEM NO.	PAGE NO.	PARA-GRAPH	LINE NO. *	FIGURE NO.	TABLE NO.	RECOMMENDED CHANGES AND REASON (Provide exact wording of recommended changes, if possible).	
	0004 00-2	4-7				Wrong POC is listed. <div style="border: 1px solid black; padding: 20px; text-align: center; font-size: 48px; font-weight: bold; transform: rotate(-10deg);">SAMPLE</div>	
<i>*Reference to line numbers within the paragraph or subparagraph.</i>							
TYPED NAME, GRADE OR TITLE Your Name				TELEPHONE EXCHANGE/AUTOVON, PLUS EXTENSION		SIGNATURE Your Signature	

TO: <i>(Forward direct to addressee listed in publication)</i> AMSTALC-LMIT / TECH PUBS, TACOM-RI 1 Rock Island Arsenal Rock Island, IL 61299-7630	FROM: <i>(Activity and location) (Include ZIP Code)</i> Your address	DATE Date you filled out this form
--	--	--

PART II – REPAIR PARTS AND SPECIAL TOOL LISTS AND SUPPLY CATALOGS/SUPPLY MANUALS

PUBLICATION NUMBER TM 9-2350-256-20-1	DATE 27 November 2005	TITLE Recovery Vehicle, Full Tracked: Medium, M88A1
--	--------------------------	---

PAGE NO.	COLM NO.	LINE NO.	NATIONAL STOCK NUMBER	REFERENCE NO.	FIGURE NO.	ITEM NO.	TOTAL NO. OF MAJOR ITEMS SUPPORTED	RECOMMENDED ACTION

PART III – REMARKS *(Any general remarks or recommendations, or suggestions for improvement of publications and blank forms. Additional blank sheets may be used if more space is needed.)*

TYPED NAME, GRADE OR TITLE Your Name	TELEPHONE EXCHANGE/AUTOVON, PLUS EXTENSION	SIGNATURE Your Signature
---	--	-----------------------------

RECOMMENDED CHANGES TO PUBLICATIONS AND BLANK FORMS						Use Part II (reverse) for Repair Parts and Special Tool Lists (RPSTL) and Supply Catalogs/Supply Manuals (SC/SM).	DATE
For use of this form, see AR 25-30: the proponent agency is ODISC4.							
TO: (Forward to proponent of publication or form) (Include ZIP Code) AMSTALC-LMIT / TECH PUBS, TACOM-RI 1 Rock Island Arsenal Rock Island, IL 61299-7630						FROM: (Activity and location) (Include ZIP Code)	
PART I - ALL PUBLICATIONS (EXCEPT RPSTL AND SC/SM) AND BLANK FORMS							
PUBLICATION/FORM NUMBER TM 9-2350-256-20-1					DATE 27 November 2005	TITLE Recovery Vehicle, Full Tracked: Medium, M88A1	
ITEM NO.	PAGE NO.	PARA-GRAPH	LINE NO. *	FIGURE NO.	TABLE NO.	RECOMMENDED CHANGES AND REASON <i>(Provide exact wording of recommended changes, if possible).</i>	
<i>*Reference to line numbers within the paragraph or subparagraph.</i>							
TYPED NAME, GRADE OR TITLE				TELEPHONE EXCHANGE/AUTOVON, PLUS EXTENSION		SIGNATURE	

TO: <i>(Forward direct to addressee listed in publication)</i> AMSTALC-LMIT / TECH PUBS, TACOM-RI 1 Rock Island Arsenal Rock Island, IL 61299-7630	FROM: <i>(Activity and location) (Include ZIP Code)</i>	DATE
--	--	-------------

PART II – REPAIR PARTS AND SPECIAL TOOL LISTS AND SUPPLY CATALOGS/SUPPLY MANUALS

PUBLICATION NUMBER TM 9-2350-256-20-1	DATE 27 November 2005	TITLE Recovery Vehicle, Full Tracked: Medium , M88A1
--	--------------------------	--

PAGE NO.	COLM NO.	LINE NO.	NATIONAL STOCK NUMBER	REFERENCE NO.	FIGURE NO.	ITEM NO.	TOTAL NO. OF MAJOR ITEMS SUPPORTED	RECOMMENDED ACTION

PART III – REMARKS *(Any general remarks or recommendations, or suggestions for improvement of publications and blank forms. Additional blank sheets may be used if more space is needed.)*

TYPED NAME, GRADE OR TITLE	TELEPHONE EXCHANGE/AUTOVON, PLUS EXTENSION	SIGNATURE
----------------------------	--	-----------

RECOMMENDED CHANGES TO PUBLICATIONS AND BLANK FORMS						Use Part II (reverse) for Repair Parts and Special Tool Lists (RPSTL) and Supply Catalogs/Supply Manuals (SC/SM).	DATE
For use of this form, see AR 25-30: the proponent agency is ODISC4.							
TO: (Forward to proponent of publication or form) (Include ZIP Code) AMSTALC-LMIT / TECH PUBS, TACOM-RI 1 Rock Island Arsenal Rock Island, IL 61299-7630						FROM: (Activity and location) (Include ZIP Code)	
PART I - ALL PUBLICATIONS (EXCEPT RPSTL AND SC/SM) AND BLANK FORMS							
PUBLICATION/FORM NUMBER						DATE	TITLE
TM 9-2350-256-20-1						27 November 2005	Recovery Vehicle, Full Tracked: Medium, M88A1
ITEM NO.	PAGE NO.	PARA-GRAPH	LINE NO. *	FIGURE NO.	TABLE NO.	RECOMMENDED CHANGES AND REASON (Provide exact wording of recommended changes, if possible).	
<i>*Reference to line numbers within the paragraph or subparagraph.</i>							
TYPED NAME, GRADE OR TITLE				TELEPHONE EXCHANGE/AUTOVON, PLUS EXTENSION		SIGNATURE	

TO: <i>(Forward direct to addressee listed in publication)</i> AMSTALC-LMIT / TECH PUBS, TACOM-RI 1 Rock Island Arsenal Rock Island, IL 61299-7630	FROM: <i>(Activity and location) (Include ZIP Code)</i>	DATE
--	--	-------------

PART II – REPAIR PARTS AND SPECIAL TOOL LISTS AND SUPPLY CATALOGS/SUPPLY MANUALS

PUBLICATION NUMBER TM 9-2350-256-20-1	DATE 27 November 2005	TITLE Recovery Vehicle, Full Tracked: Medium, M88A1
--	--------------------------	---

PAGE NO.	COLM NO.	LINE NO.	NATIONAL STOCK NUMBER	REFERENCE NO.	FIGURE NO.	ITEM NO.	TOTAL NO. OF MAJOR ITEMS SUPPORTED	RECOMMENDED ACTION

PART III – REMARKS *(Any general remarks or recommendations, or suggestions for improvement of publications and blank forms. Additional blank sheets may be used if more space is needed.)*

TYPED NAME, GRADE OR TITLE	TELEPHONE EXCHANGE/AUTOVON, PLUS EXTENSION	SIGNATURE
----------------------------	--	-----------

By Order of the Secretary of the Army:

PETER J. SCHOOMAKER
General, United States Army
Chief of Staff

Official:



SANDRA R. RILEY
Administrative Assistant to the
Secretary of the Army
0516401

DISTRIBUTION: To be distributed in accordance with the initial distribution requirements for IDN: 370945, requirements for TM 9-2350-256-20-1.

The Metric System and Equivalents

Linear Measure

1 centimeter = 10 millimeters = .39 inch
 1 decimeter = 10 centimeters = 3.94 inches
 1 meter = 10 decimeters = 39.37 inches
 1 decameter = 10 meters = 32.8 feet
 1 hectometer = 10 decameters = 328.08 feet
 1 kilometer = 10 hectometers = 3,280.8 feet

Weights

1 centigram = 10 milligrams = .15 grain
 1 decigram = 10 centigrams = 1.54 grains
 1 gram = 10 decigram = .035 ounce
 1 decagram = 10 grams = .35 ounce
 1 hectogram = 10 decagrams = 3.52 ounces
 1 kilogram = 10 hectograms = 2.2 pounds
 1 quintal = 100 kilograms = 220.46 pounds
 1 metric ton = 10 quintals = 1.1 short tons

Liquid Measure

1 centiliter = 10 milliliters = .34 fl. ounce
 1 deciliter = 10 centiliters = 3.38 fl. ounces
 1 liter = 10 deciliters = 33.81 fl. ounces
 1 dekaliters = 10 liters = 2.64 gallons
 1 hectoliter = 10 dekaliters = 26.42 gallons
 1 kiloliter = 10 hectoliters = 264.18 gallons

Square Measure

1 sq. centimeter = 100 sq. millimeters = .155 sq. inch
 1 sq. decimeter = 100 sq. centimeters = 15.5 sq. inches
 1 sq. meter (centare) = 100 sq. decimeters = 10.76 sq. feet
 1 sq. decameter (are) = 100 sq. meters = 1,076.4 sq. feet
 1 sq. hectometer (hectare) = 100 sq. decameters = 2.47 acres
 1 sq. kilometer = 100 sq. hectometers = .386 sq. mile

Cubic Measure

1 cu. centimeter = 1000 cu. millimeters = .06 cu. inch
 1 cu. decimeter = 1000 cu. centimeters = 61.02 cu. inches
 1 cu. meter = 1000 cu. decimeters = 35.31 cu. feet

Approximate Conversion Factors

To change	To	Multiply by	To change	To	Multiply by
inches	centimeters	2.540	ounce-inches	Newton-meters	.007062
feet	meters	.305	centimeters	inches	.394
yards	meters	.914	meters	feet	3.280
miles	kilometers	1.609	meters	yards	1.094
square inches	square centimeters	6.451	kilometers	miles	.621
square feet	square meters	.093	square centimeters	square inches	.155
square yards	square meters	.836	square meters	square feet	10.764
square miles	square kilometers	2.590	square meters	square yards	1.196
acres	square hectometers	.405	square kilometers	square miles	.386
cubic feet	cubic meters	.028	square hectometers	acres	2.471
cubic yards	cubic meters	.765	cubic meters	cubic feet	35.315
fluid ounces	milliliters	29.573	cubic meters	cubic yards	1.308
pints	liters	.473	milliliters	fluid ounces	.034
quarts	liters	.946	liters	pints	2.113
gallons	liters	3.785	liters	quarts	1.057
ounces	grams	28.349	liters	gallons	.264
pounds	kilograms	.454	grams	ounces	.035
short tons	metric tons	.907	kilograms	pounds	2.205
pound-feet	Newton-meters	1.356	metric tons	short tons	1.102
pound-inches	Newton-meters	.11296			

Temperature (Exact)

°F	Fahrenheit temperature	5/9 (after subtracting 32)	Celsius temperature	°C
----	------------------------	----------------------------	---------------------	----

